

MICRO 100[®]

Make More With Micro 100

1,000+ New Tools

Fill more machine positions in your next setup with our new turning and rotational product lines.

2023 Product Catalog

MULTIPLE MACHINE - SET UP SHEET

Customer:	WXYZ Precision
Part Number:	549032
Part Name:	Adapter A-1
Rev Level:	1
Material:	C368000 Brass

Preferred Machine:	32mm Swiss
Coolant type:	Oil, High Pressure
Optional Machine:	Multifunction Lathe
Coolant type:	Water Soluble Synthetic, High Pressure

Operation	Tool	Brand	Position	Holder Type	Coolant Thru	Swiss Set up information		Offset Number
						Brand	Part Number	
Spot ID thread end	QSPD-250-90	Micro100	T31	ER 16 Collet		Micro100	QTSP-250-750	
Lead end	DR-250-2	Micro100	T11	Coolant Thru		Micro100	ER16-250	
	QBT4-140375	Micro100	T31	Coolant Thru		Micro100	QTSP-187-750	
	QSPD-250-90	Micro100	T02	Coolant Thru		Micro100	QTSP-250-750	
		Micro100	T08	N/A		Micro100	N/A	
		Micro100	T09	Taper Integrated		Micro100	ER161-3-984	
		Micro100	T09	Taper Integrated		Micro100	ER161-2-984	
		Micro100	T09	Coolant Thru		Micro100	QTSP-187-750	
		Micro100	T09	Coolant Thru		Micro100	THS-4-750	
		Micro100	T09	Coolant Thru		Micro100	ER16-375	



Your Source for Fully
Stocked Turning Tools
Make More with Micro 100

In today's competitive machining industry, the pressure is high for shops to increase metal removal rates, boost productivity, and improve their bottom line. When “making more” is pivotal, you can count on Micro 100 to help you gain a competitive edge and set your shop up for success. From our expansive tool offering and off-the-shelf availability, to our excellent product quality and highly repeatable Micro-Quik Quick Change system, we guarantee you'll Make More with Micro 100 every time you choose us.

Endurance and Quality

Your search for high performance, solid round turning tools stops here! We manufacture an extremely broad selection of tooling for traditional and swiss lathes, designed to take your shop further.

Powerful Performance

With Micro 100, “difficult to machine materials” are easier to work in than ever before. Our products excel at vastly increased speed and feed rates and provide exceptional results, even in the toughest jobs.

Earned Reputation

Micro 100's stellar reputation is the result of more than six decades serving the manufacturing industry with high precision, tightly-toleranced turning tools that drive shop productivity.

Technical Resources

Now offering downloadable Sim Files in .STEP format for every one of our catalog items, and user-friendly Speeds & Feeds charts for all quick change and standard shank turning tools.

**HARVEY
PERFORMANCE**
COMPANY

Harvey Performance Company combines the leading Harvey Tool, Helical Solutions, Micro 100, Titan USA, and CoreHog brands to provide world class tooling, unmatched service, and innovative solutions that increase productivity for our customers.

 <p>Think Harvey Tool First</p> <p>More than 28,000 miniature and specialty end mills. Ship today, in your machine tomorrow.</p>	 <p>Let Helical Impress You</p> <p>Material-optimized high performance carbide end mills. Run faster, push harder, machine smarter.</p>	 <p>Make More with Micro 100</p> <p>Exceptional quality turning tools designed for durability and performance in a range of difficult-to-machine materials.</p>	 <p>Trust in Titan USA</p> <p>Quality Cutting Tools at Exceptional Value</p>	 <p>Innovative Tools for Innovative Materials</p> <p>The industry's most innovative and advanced composite and honeycomb core cutting tools.</p>
--	---	---	--	--

Reconfigured Catalog to help you **Make More.**

In effort to simplify your search for your next job's perfect Micro 100 solution, we've reorganized our catalog to promote enhanced navigation and to highlight the unmatched diversity of our product offering. In doing so, we have added two new categories to this catalog: Tool Holders & Systems (pg 13), and Holmaking & Threading (pg 203).



Tool Holders & Systems

pg 13



Turning Tools

Quick Change - pg 46
Standard - pg 103



Holemaking & Threading

pg 203

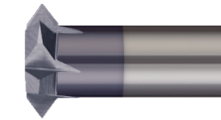

Milling Tools

pg 215



Blanks, Sets & Accessories

pg 299

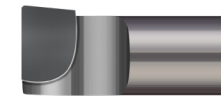

Taper Integrated Holders pg 39
Quick Change PSC Holders pg 23
Standard Straight Holders pg 35
ER Collets pg 41

More than 1000 **NEW!** Tools in 2023

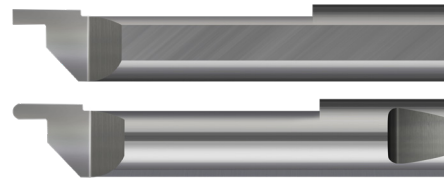

Quick Change & Standard
Face Grooving - Internal Tooth
Quick Change pg 85 | Standard pg 154

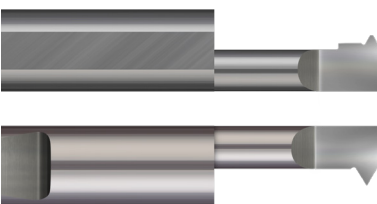

Quick Change Threading Tools pg 89

- UN Threads - Single Point - Left Hand
- UN Topping - Single Point
- Metric Topping - Single Point

Standard Threading Tools pg 158

- UN Topping - Single Point
- Metric Topping - Single Point



Miniature Drills pg 207

Tool Holders & Systems NEW!

pg 13



Standard Straight Holder - Long Length on pg 37



Taper Integrated Holders - Solid ER on pg 39

Quick Change Holders & Parts

Quick Change Holders NEW!	14
Quick Change Parts	29

Standard Holders & Parts

Standard Holders NEW!	33
Standard Parts	38

Rotational Holders & Parts

Taper Integrated Holders NEW!	39
Taper Integrated Parts NEW!	40

Collets

ER Collets NEW!	41
---	----

Turning Tools

pg 45



Quick Change Boring Tools - Right Hand on pg 51



Standard Miniature Boring Tools on pg 46

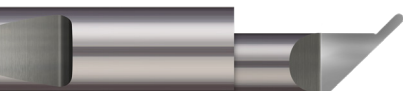

Quick Change Grooving Tools - Undercutting Full Radius on pg 79

Internal Diameter (ID) - Quick Change

Quick Change - Boring Tools	46
Right Hand NEW SIZES!	46
Helical Back Rake	56
Top Rake Chipbreaker	58
Boring Head Tools	60
Reverse Boring	61
Quick Change - Profiling Tools	62
Quick Change - Grooving Tools	68
Retaining Ring	68
Full Radius	76
Undercutting	79
Face Grooving NEW!	80
Quick Change - Threading Tools NEW!	89
Quick Change - Holmaking Tools NEW SIZES!	96
Quick Change - Blanks	101

Internal Diameter (ID) - Standard

Standard - Boring Tools	103
Right Hand	103
Left Hand	116
Helical Back Rake	119
Top Rake Chipbreaker	123
Brazed	125

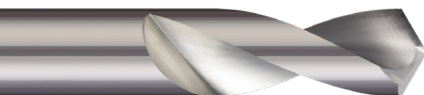

Quick Change Spotting Drills on pg 96



Standard Grooving Tools - Face Grooving - Square on pg 149



Brazed Forming Tools - 90° Radius Concave - Right Hand on pg 188

Turning Tools (cont.)

Standard - Profiling Tools	127
Standard - Grooving Tools	133
Retaining Ring	133
Full Radius	144
Undercutting	146
O-Ring Grooving	148
Face Grooving NEW!	149
Standard - Threading Tools NEW!	158

Internal Diameter (ID) - Indexable

Indexable - Boring Bars	172
-------------------------	-----

Outside Diameter (OD) - Indexable

Indexable - Tool Holders	176
--------------------------	-----

Outside Diameter (OD) - Brazed

Brazed - Box Turning Tools	181
Brazed - Forming Tools	182
Brazed - Grooving Tools	190
Brazed - Threading Tools	195
Brazed - Screw Machine Tools	196
Brazed - Cut Off Tools	198

Holemaking & Threading Tools

NEW!

pg 203



Drills - Miniature on pg 207

Drills NEW!	204
Combined Drill & Countersinks	209
Thread Milling Cutters	210

Milling Tools

pg 215



End Mills - Ball - 2, 3, 4 Flute Stub & Standard on pg 228

End Mills

End Mills - Square	216
End Mills - Ball	228
End Mills - Corner Radius	236

Table of Contents Continues on Next Page



End Mills for Aluminum Alloys - Square - Single Flute - Upcut Router on pg 275

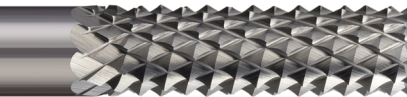

Diamond Cut End Mills for Composites on pg 280



Dovetail Cutters on pg 297

Milling Tools (cont.)	
Material Specific End Mills	
End Mills for Hardened Steels	239
End Mills for Steels & High Temp Alloys	240
End Mills for Aluminum Alloys	274
End Mills for Plastics & Composites	277
Specialty Profiles	
Undercutting End Mills	283
Drill/End Mills	285
Chamfer Cutters	287
Runner Cutters	288
Engraving Cutters	289
Keyseat Cutters	293
Corner Rounding End Mills	295
Dovetail Cutters	297
Indexable	298

Blanks, Sets & Accessories

pg 299

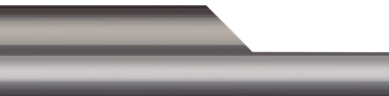

Blanks - Split End - Double Ended on pg 305

Blanks	300
Sets	306
Accessories	318

Tool Number Prefix

Simply find the page your desired Micro 100 product is found on by searching for its Tool Number Prefix.

Prefix	Page	Prefix	Page	Prefix	Page
AECM	236	BB	111	BLR / BLRM	233
AELM	224	BB Set	307	BMR / BMRM	228
AEMM	219	BBL	116	BMS	228
AL	182	BBM	105	BMSM	228
AMRM	216	BBS	105	BR	183
AR	182	BEF / BEFM	251, 253	BT/BTL	181
ARC	271, 276	BEL / BELM	232	C	184
ARM / ARMM	248, 274	BEM / BEMM	228	CL	199
ASM / ASMM	248, 274	BL	183	CPG	319

Prefix	Page	Prefix	Page	Prefix	Page	Prefix	Page
CR	198	IDRT	171	QITL <small>NEW!</small>	92	RT	196
CRE	296	IT	158	QMBB	46	RTC / RTCM	289
CREM	295	IT Set	309	QMFR	76	RXD	186
CRT	184	ITL	161	QMRR	68	RXL	187
CS	287	ITM	163	QPA	64	SAT	169
CT	200	KC	293	QPF	66	SBM / SBMM	283
D	185	LC	197	QPR	62	SD	206
DC Set	317	LT	196	QRB	61	SDH / SDHM	246
DC / DCM	209	LTR	171	QRR	70	SEM	219
DM / DMM	285	MBB / MBBM	103	QRRC	74	SFA / SFAM	275
DR <small>NEW!</small>	207	MBB Set	306	QSD	99	SFBM	233
DT	297	MBC	288	QSG	28	SFL / SFLM	279
E	195	MEF / MEFM	240,257	QSP	101	SFP / SFPM	277
EL	196	MMBM	233	QSPD	96	SHL / SHLM	247
EMH / EMHM	250	MMRM	238	QSR	102	SHR / SHRM	247
EMS / EMSM	226	MRF	288	QT <small>NEW!</small>	23	SME	216
ER	195	MRR	133	QTH / QTHM	17	SPD	204
ER (Collets) <small>NEW!</small>	41	MRT	288	QTHL / QTHML	19	SPG	319
ERI <small>NEW!</small>	39	MTR	214	QTMT <small>NEW!</small>	95	SR / SRM	301
ERS / ERM <small>NEW!</small>	44	OR	148	QTS / QTSP	14	T	201
FG	149	PA	129	QTSL / QTSP	16	TBB / TBBL	125
FGC	151	PBT	123	QTT <small>NEW!</small>	93	TBB / TBBL Sets	310
FGF	153	PF	131	QUP	79	TBBC / TBBCL	126
FGI <small>NEW!</small>	154	PR	127	QZST	24-27	TD	319
FGIC <small>NEW!</small>	156	QBB	48,51	RAD	188	TH / THM/THMA	33
FGIF <small>NEW!</small>	157	QBM	60	RAD Set	311	THS <small>NEW!</small>	35
FR	144	QBT	58	RAL	189	THSL <small>NEW!</small>	37
FRT	190	QC	31	RAL Set	312	TM	210-213
GEC	236	QCS	100	RC	197	TMM	214
GEL / GELM	224	QDC	98	RDA	280	TMT <small>NEW!</small>	166
GEM / GEMM	219	QDH	21	RDB	280	TP	319
GLR / GLRM	225	QDS / QDSM	21	RDC	281	TPG	319
GR	191	QFG	80	RDD	281	TRG	190
GR-F	192	QFGC	82	RDE	282	TT <small>NEW!</small>	164
GS	193	QFGF	84	RME / RMEM	216	T-V	202
GS-F	194	QFGI <small>NEW!</small>	85	RNC / RNCM	289	UC	146
HBB / HBM	121	QFGIC <small>NEW!</small>	87	RR / RRM	134	UP	147
HBBC	119	QFGIF <small>NEW!</small>	88	RR Set	308	VHM / VHMM	249,268,272
HMCM	239	QFR	77	RRC	142	VHS / VHSM	249,268,272
HR / HRM	300	QHBBC	56	RRL	140	VLM	269
IAT	167	QI	28	RS / RSM	304	VLR	273
IDLT	170	QIT	89	RSC / RSCM	289	VLR / VLRM	270

Micro 100 Micro-Quik

Radial and axial repeatability | Tip-to-tip consistency | Part-to-part accuracy

A breakthrough tool change system that saves machinists countless hours by allowing for incredibly fast tool changes without sacrificing locational repeatability or machining accuracy.

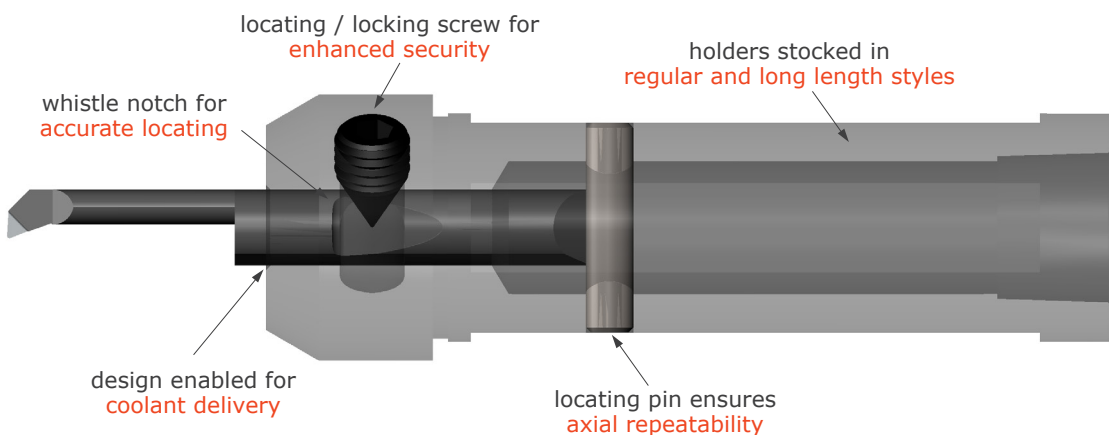

This foolproof system delivers impressive radial and axial repeatability, tip-to-tip consistency, and part-to-part accuracy.

In critical accuracy situations, many customers have enjoyed .0002" tool-to-tool repeatability, achieved in fewer than 30 seconds. This is 90% faster than conventional tool change methods, which oftentimes take in excess of 5 minutes, start-to-finish.

Because of its simplicity and extremely low margin for error, Micro-Quik is the preferred tool change method of machine shops worldwide, including those employing new and up-and-coming machinists.

Our Customers Experience Incredible Benefits

- ✓ Tool changes in less than 30 seconds
- ✓ Fewer tool change errors
- ✓ Impressive radial and axial repeatability
- ✓ Increased machine up-time.

For Quick Change Tool Holder Options & Benefits Chart, See Page 11

Uniquely
Designed to
help you
Make More.

Micro 100's Micro-Quik features a whistle notch configuration, proven to enhance axial accuracy over the standard set screw design used by other quick change system manufacturers. The whistle notch used by Micro 100 ensures that the tool is always held in location, anchored accurately in place, and pushed completely against the locating mechanism.

This axial consistency prevents all-too-common tool failures, scrap parts, and lost machine time due to improperly secured tools.



How It Works

During tool changes, the precision ground bevel specially engineered on the rear of each Micro 100 quick change tool aligns with a locating pin in the quick change tool holder. The distance from this locational point to the tip of the tool is highly controlled, meaning that our Micro-Quik tooling system ensures a very high degree of tool length and centerline repeatability.

Easy 3-Step Process

1. Remove the existing tool by loosening the locating/locking screw.
2. Remove the used tool.
3. Insert the new tool and retighten the locating/locking screw.

Quick Change Tool Holders

Micro 100's offering of quick change tool holders, including our popular headless-style products, deliver unparalleled speed, repeatability, and accuracy. These unique holders are engineered for use in all **Swiss, standard lathe, or multi-function lathe machines** and are designed for ease of installation through the back side of the tool block.

NEW Quick Change Holders

The design of Micro 100's new Quick Change PSC Holders combine Capto® compatibility with our proprietary Micro-Quik quick change system, which boosts shop efficiency by allowing for incredibly accurate tool changes in under 30 seconds

- PSC flange designed for use on lathes with or without an automatic tool changer
- Short head length accommodates smaller work envelopes and provides maximum rigidity
- ID threaded for use with a coolant adapter
- Heat treated for added durability
- Black oxide coated on all non-ground surfaces for corrosion resistance

Expansive Tool Offering for Quick Change Holders

- Boring Tools
- Axial Profiling Tools
- Radial Profiling Tools
- Top Rake Chipbreakers
- Grooving Tools
- Face Grooving Tools
- Undercutting Tools
- Threading Tools
- Spotting Drills
- Combined Drill & Countersinks
- Spade Drills
- Chamfer Tools

More Than 2,800 Stocked Quick Change Tools!

Application Specific Tool Holders



PSC Holder

Optimized for machines with PSC / Capto® connections

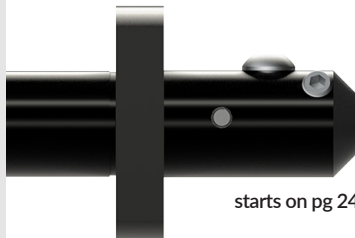

Star Swiss Machine Holders

Designed for Star Swiss Machines



Grinding Holder

Engineered for grinders and some flat and slant bed lathes.

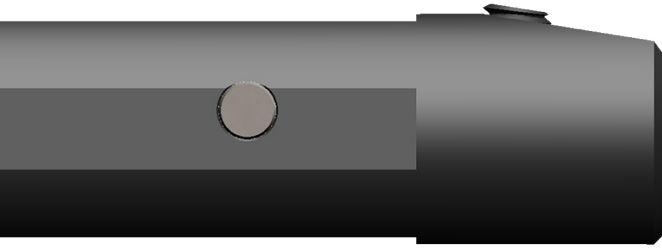

Straight Quick Change Tool Holders

- Enhanced application flexibility and headless design
- Optimized for use in any Swiss, standard lathe, or multi-function lathe
- Offered with ported, plumbed, or ported & plumbed coolant access options
- Designed for ease of installation through the back side of the tooling block
- Stocked in standard and long length styles

Plumbed & Ported
QTSP pg 14

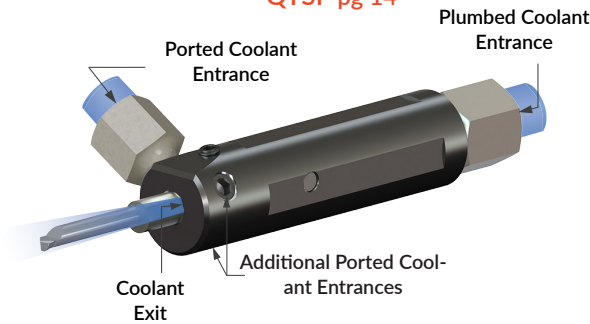

Headless tool holders engineered for use in any Swiss, standard, or lathe machine. Designed for Ease of installation through the back side of the tool block

Quick Reference Guide

	Straight Holder Standard Length	Straight Holder Long Length	Headed Holder Standard Length	Headed Holder Long Length	Tool Holder System Double Ended Modular
	QTS / QTSP	QTSL / QTSPL	QTH / QTHM	QTHL / QTHML	QDH / QDS / QDSM
	A reliable go-to for maximum machine compatibility and best-in-class coolant delivery options.		"The Original" holder designed to excel in high axial force operations.		Double-ended for use in twin spindle and Y-axis tooling block locations.
	pg 14	pg 16	pg 17	pg 19	pg 21
Coolant Access Type	Plumbed & Ported	Plumbed & Ported	Plumbed	Plumbed	Ported
Headless Holder Design for Easy Machine Access	✓	✓			✓
Adjustable Holder Depth in the Block	✓	✓			✓
Can Be Loaded Through Back of Tooling Block for Ease of Use	✓	✓			✓
Headed Design for Repeatable Holder Replacement			✓	✓	
Long Length for Extended Reach Applications		✓		✓	
Modular & Double-Ended for Added Versatility					✓
Locating/locking screw Number/Orientation	1/Top	1/Top	1/Side	1/Side	1/Side

Let Us Help You Make More With Micro 100

Stay Connected With Us

- ✓ Micro 100 Product Releases
- ✓ Valuable Technical Resources
- ✓ Machining Tips and Best Practices
- ✓ Giveaways & Promotions





Join Our Email List

Scan the QR code below to sign up for our email list! Our weekly email delivers valuable information about Micro 100 products and technical resources directly to your inbox. Be the first to know of newly-released tools to gain an immediate leg-up on the competition!



Follow Us on Social

From amazing tool geometries to beautiful final parts made with Micro 100 turning tools, you'll find it all on our social media channels! Also, be sure to send us your pictures and videos! We love to check out what you accomplish with our tools.

-  Instagram @micro100
-  TikTok @micro.100
-  Facebook @micro100
-  LinkedIn @micro100
-  Youtube @micro.100

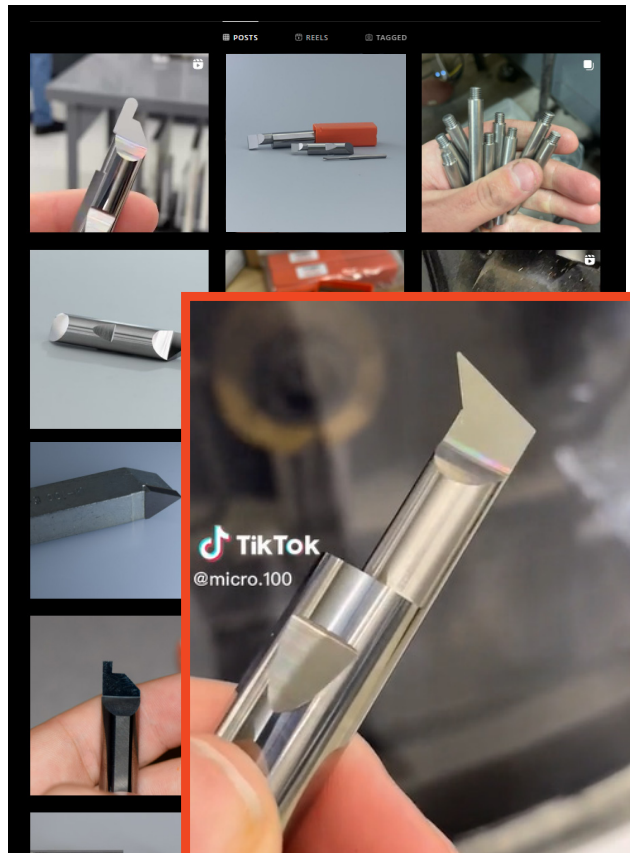



NEW!

TOOL HOLDERS & SYSTEMS

Quick Change Holders & Parts

Quick Change Holders	14
Quick Change Parts	29

Standard Holders & Parts

Standard Holders	33
Standard Parts	38

Rotational Holders & Parts

Taper Integrated Holders	39
Rotational Parts	40

Collets

ER Collets	41
------------	----

Quick Change Holders

QTS / QTSP

Straight Holder – Standard Length

Quick Change – Holders

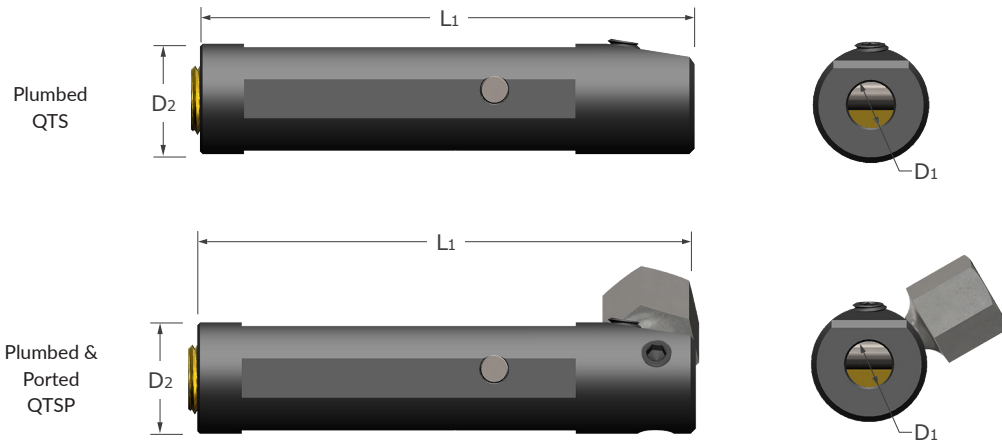

- Headless tool holder engineered for maximum versatility in any Swiss, standard lathe, or multi-function lathe
- Standard plumbed and 3 ported options for more enhanced coolant accessibility
- Proprietary Micro-Quik quick change system maximizes productivity through reliable accuracy and locational repeatability
- Headless design allows for installation through the back of the tooling block in machines where work envelope is limited
- Top screw orientation for easy access to set screw without interference of adjacent tools
- 4 alignment flats allow for multiple tool engagements and holder orientations
- Heat treated and black oxide coated for durability and corrosion resistance
- Tool holder includes: hex wrench, locating/locking screw, porting plugs, straight coolant adapter and applicable brass plug
- Precision manufactured in the USA

Internal Diameter	Shank Diameter	Ported Thread	Plumbed Thread	Overall Length	Locating Locking Screw	Tool Holder	
$D_1 \begin{matrix} +.0005" \\ -.0000" \end{matrix}$	$D_2 \begin{matrix} -.0003" \\ -.0008" \\ -.008mm \\ -.020mm \end{matrix}$			L_1		Tool #	Price
.1875	12 mm	-	1/8-27	2.8	40317	QTS-187-472	135.90
.1875	.5000	-	1/8-27	2.8	40317	QTS-187-500	135.90
.1875	.6250	-	1/8-27	2.8	40317	QTS-187-625	147.25
.1875	16 mm	-	1/8-27	2.8	40317	QTS-187-630	147.25
.1875	.7500	1/4-28 HP	1/8-27	2.8	40316	QTSP-187-750	191.10
.1875	20 mm	1/4-28 HP	1/8-27	2.8	40316	QTSP-187-787	191.10
.1875	22 mm	1/4-28 HP	1/8-27	2.8	40316	QTSP-187-866	191.10
.1875	25 mm	1/4-28 HP	1/8-27	2.8	40315	QTSP-187-984	191.10
.1875	1.0000	1/4-28 HP	1/8-27	2.8	40315	QTSP-187-1000	191.10

Continued on next page

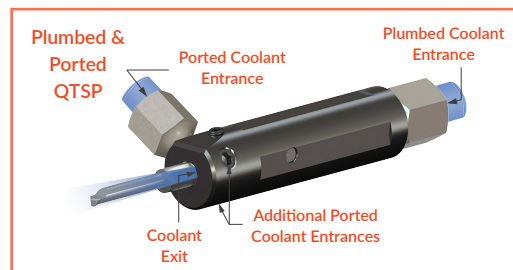
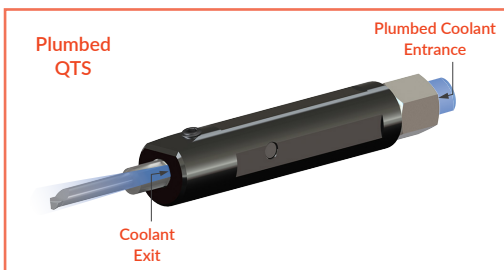

See pg 29-32 for replacement parts and accessories

QTS / QTSP

Quick Change Holders

Straight Holder – Standard Length (cont.)

Continued from previous page

Internal Diameter	Shank Diameter	Ported Thread	Plumbed Thread	Overall Length	Locating Locking Screw	Tool Holder	
$D_1 \begin{matrix} +.0005" \\ -.0000" \end{matrix}$	$D_2 \begin{matrix} -.0003" \\ -.0008" \\ -.008mm \\ -.020mm \end{matrix}$			L1		Tool #	Price
.2500	12 mm	-	1/8-27	2.8	40317	QTS-250-472	135.90
.2500	.5000	-	1/8-27	2.8	40317	QTS-250-500	135.90
.2500	.6250	-	1/8-27	2.8	40317	QTS-250-625	147.25
.2500	16 mm	-	1/8-27	2.8	40317	QTS-250-630	147.25
.2500	.7500	1/4-28 HP	1/8-27	2.8	40316	QTSP-250-750	191.10
.2500	20 mm	1/4-28 HP	1/8-27	2.8	40316	QTSP-250-787	191.10
.2500	22 mm	1/4-28 HP	1/8-27	2.8	40316	QTSP-250-866	191.10
.2500	25 mm	1/4-28 HP	1/8-27	2.8	40316	QTSP-250-984	191.10
.2500	1.0000	1/4-28 HP	1/8-27	2.8	40315	QTSP-250-1000	191.10
.3125	.6250	-	1/4-18	2.8	40317	QTS-312-625	147.25
.3125	16 mm	-	1/4-18	2.8	40317	QTS-312-630	147.25
.3125	.7500	-	1/4-18	2.8	40317	QTS-312-750	158.55
.3125	20 mm	-	1/4-18	2.8	40317	QTS-312-787	158.55
.3125	22 mm	1/4-28 HP	1/4-18	2.8	40317	QTSP-312-866	191.10
.3125	25 mm	1/4-28 HP	1/4-18	2.8	40316	QTSP-312-984	191.10
.3125	1.0000	1/4-28 HP	1/4-18	2.8	40316	QTSP-312-1000	191.10
.3750	.6250	-	1/4-18	2.8	40317	QTS-375-625	147.25
.3750	.7500	-	1/4-18	2.8	40317	QTS-375-750	158.55
.3750	20 mm	-	1/4-18	2.8	40317	QTS-375-787	158.55
.3750	22 mm	1/4-28 HP	1/4-18	2.8	40317	QTSP-375-866	191.10
.3750	25 mm	1/4-28 HP	1/4-18	2.8	40316	QTSP-375-984	191.10
.3750	1.0000	1/4-28 HP	1/4-18	2.8	40316	QTSP-375-1000	191.10
.5000	.7500	-	3/8-18	2.8	40317	QTS-500-750	158.55
.5000	1.0000	1/4-28 HP	3/8-18	2.8	40317	QTSP-500-1000	174.70

Quick Change – Holders

See pg 29-32 for replacement parts and accessories

Quick Change Holders

QTSL / QTSPL

Straight Holder – Long Length

Quick Change – Holders

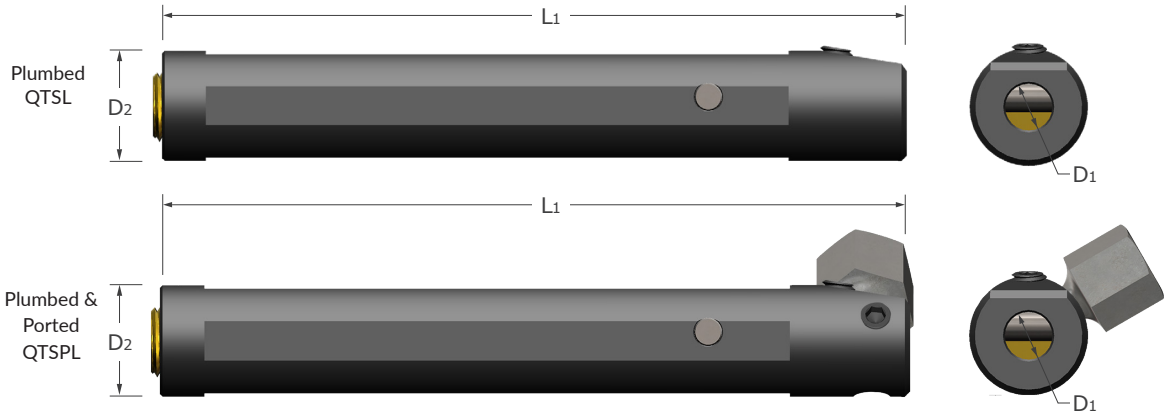

- Quick change, long length tool holder designed for applications requiring an extended reach
- Headless tool holder engineered for maximum versatility in any Swiss, standard lathe, or multi-function lathe
- Standard plumbed and 3 ported options for more enhanced coolant accessibility
- Proprietary Micro-Quik quick change system maximizes productivity through reliable accuracy and locational repeatability
- Headless design for installation through the back of the tooling block in machines where work envelope is limited
- Top screw orientation for easy access to set screw without interference of adjacent tools
- 4 alignment flats allow for multiple tool engagements and holder orientations
- Heat treated and black oxide coated for durability and corrosion resistance
- Tool holder includes: hex wrench, locating/locking screw, porting plugs, straight coolant adapter and applicable brass plug
- Precision manufactured in the USA

Internal Diameter	Shank Diameter	Ported Thread	Plumbed Thread	Overall Length	Locating Locking Screw	Tool Holder	
D1 $+0.0005"$ $-0.0000"$	D2 $-0.0003"$ $-0.0008"$ $-0.08mm$ $-0.20mm$			L1		Tool #	Price
.1875	.7500	1/4-28 HP	1/8-27	5.8	40316	QTSPL-187-750	234.80
.1875	20 mm	1/4-28 HP	1/8-27	5.8	40316	QTSPL-187-787	234.80
.1875	22 mm	1/4-28 HP	1/8-27	5.8	40316	QTSPL-187-866	234.80
.1875	25 mm	1/4-28 HP	1/8-27	5.8	40315	QTSPL-187-984	234.80
.1875	1.0000	1/4-28 HP	1/8-27	5.8	40315	QTSPL-187-1000	234.80
.2500	.7500	1/4-28 HP	1/8-27	5.8	40316	QTSPL-250-750	234.80
.2500	20 mm	1/4-28 HP	1/8-27	5.8	40316	QTSPL-250-787	234.80
.2500	22 mm	1/4-28 HP	1/8-27	5.8	40316	QTSPL-250-866	234.80
.2500	25 mm	1/4-28 HP	1/8-27	5.8	40316	QTSPL-250-984	234.80
.2500	1.0000	1/4-28 HP	1/8-27	5.8	40315	QTSPL-250-1000	234.80
.3125	22 mm	1/4-28 HP	1/4-18	5.8	40316	QTSPL-312-866	234.80
.3125	25 mm	1/4-28 HP	1/4-18	5.8	40316	QTSPL-312-984	234.80
.3125	1.0000	1/4-28 HP	1/4-18	5.8	40316	QTSPL-312-1000	234.80
.3750	22 mm	-	1/4-18	5.8	40317	QTSL-375-866*	196.55
.3750	25 mm	1/4-28 HP	1/4-18	5.8	40316	QTSPL-375-984	234.80
.3750	1.0000	1/4-28 HP	1/4-18	5.8	40316	QTSPL-375-1000	234.80

*Item not ported

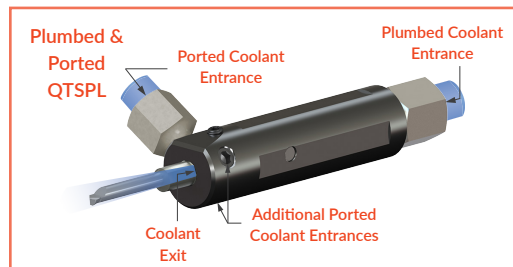
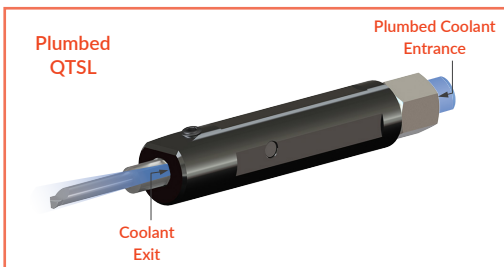

See pg 29-32 for replacement parts and accessories

QTH / QTHM

Quick Change Holders
Headed Holder – Standard Length

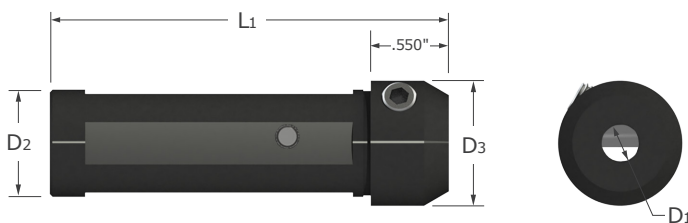

- Quick change tool holder plumbed for NPT coolant connection and designed for use in lathe applications
- Proprietary Micro-Quik quick change system maximizes productivity through reliable accuracy and locational repeatability
- Unique “3 point” locking and locating system ensures axial and radial tool repeatability, tip-to-tip consistency, and part-to-part accuracy
- 4 alignment flats allow for multiple tool engagements and holder orientations
- Heat treated and black oxide coated for durability and corrosion resistance
- Tool holder includes: hex wrench, QC-1 locating/locking screw
- Precision manufactured in the USA

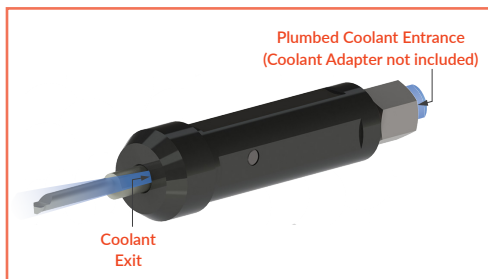

Internal Diameter	Head Diameter	Plumbed Thread	Shank Diameter	Overall Length	Tool Holder	
D1 $+0.0005$ -0.0000 "	D3 $+0.003$ -0.003 "		D2 -0.0003 -0.0008 " -0.008 mm -0.020 mm	L1	Tool #	Price
.1875	.750	1/8-27 NPT	12 mm	2.8	QTHM-312	124.60
.1875	.750	1/8-27 NPT	.5000	2.8	QTH-85	124.60
.1875	.750	1/8-27 NPT	.6250	2.8	QTH-105	135.90
.1875	.750	1/8-27 NPT	16 mm	2.8	QTHM-316	135.90
.1875	.875	1/4-18 NPT	.7500	2.8	QTH-205	147.25
.1875	.875	1/4-18 NPT	20 mm	2.8	QTHM-320	147.25
.1875	1.062	1/4-18 NPT	22 mm	2.8	QTHM-322	147.25
.1875	1.250	1/4-18 NPT	25 mm	2.8	QTHM-325	147.25
.1875	1.062	1/4-18 NPT	1.0000	2.8	QTH-405	147.25
.1875	-	1/4-18 NPT	1.2500	2.8	QTH-605	147.25
.1875	-	1/4-18 NPT	32 mm	2.8	QTHM-332	147.25
.2500	.750	1/8-27 NPT	12 mm	2.8	QTHM-412	124.60
.2500	.750	1/8-27 NPT	.5000	2.8	QTH-86	124.60
.2500	.750	1/8-27 NPT	.6250	2.8	QTH-106	135.90
.2500	.750	1/8-27 NPT	16 mm	2.8	QTHM-416	135.90
.2500	.875	1/4-18 NPT	.7500	2.8	QTH-206	147.25
.2500	.875	1/4-18 NPT	20 mm	2.8	QTHM-420	147.25
.2500	1.062	1/4-18 NPT	22 mm	2.8	QTHM-422	147.25
.2500	1.250	1/4-18 NPT	25 mm	2.8	QTHM-425	147.25
.2500	1.062	1/4-18 NPT	1.0000	2.8	QTH-406	147.25
.2500	-	1/4-18 NPT	1.2500	2.8	QTH-606	147.25
.2500	-	1/4-18 NPT	32 mm	2.8	QTHM-432	147.25

Continued on next page

Quick Change Holders

Headed Holder – Standard Length (cont.)

QTH / QTHM

Continued from previous page

Internal Diameter	Head Diameter	Plumbed Thread	Shank Diameter	Overall Length	Tool Holder	
					Tool #	Price
D1 $\begin{matrix} +.0005" \\ -.0000" \end{matrix}$	D3 $\begin{matrix} +.003" \\ -.003" \end{matrix}$		D2 $\begin{matrix} -.0003" \\ -.0008" \\ -.008mm \\ -.020mm \end{matrix}$	L1		
.3125	.875	1/8-27 NPT	.6250	2.8	QTH-107	135.90
.3125	.875	1/8-27 NPT	16 mm	2.8	QTHM-516	135.90
.3125	.875	1/4-18 NPT	.7500	2.8	QTH-207	147.25
.3125	.875	1/4-18 NPT	20 mm	2.8	QTHM-520	147.25
.3125	1.062	1/4-18 NPT	22 mm	2.8	QTHM-522	147.25
.3125	1.250	1/4-18 NPT	25 mm	2.8	QTHM-525	147.25
.3125	1.062	1/4-18 NPT	1.0000	2.8	QTH-407	147.25
.3125	-	1/4-18 NPT	1.2500	2.8	QTH-607	147.25
.3125	-	1/4-18 NPT	32 mm	2.8	QTHM-532	147.25
.3750	1.000	1/8-27 NPT	.6250	2.8	QTH-108	135.90
.3750	1.000	1/8-27 NPT	16 mm	2.8	QTHM-616	135.90
.3750	1.000	1/4-18 NPT	.7500	2.8	QTH-208	147.25
.3750	1.000	1/4-18 NPT	20 mm	2.8	QTHM-620	147.25
.3750	1.062	1/4-18 NPT	22 mm	2.8	QTHM-622	147.25
.3750	1.250	1/4-18 NPT	25 mm	2.8	QTHM-625	147.25
.3750	1.062	1/4-18 NPT	1.0000	2.8	QTH-408	147.25
.3750	-	1/4-18 NPT	1.2500	2.8	QTH-608	147.25
.3750	-	1/4-18 NPT	32 mm	2.8	QTHM-632	147.25
.5000	1.062	1/4-18 NPT	.7500	2.8	QTH-210	147.25
.5000	1.062	1/4-18 NPT	20 mm	2.8	QTHM-820	147.25
.5000	1.062	1/4-18 NPT	22 mm	2.8	QTHM-822	147.25
.5000	1.250	1/4-18 NPT	25 mm	2.8	QTHM-825	147.25
.5000	1.062	1/4-18 NPT	1.0000	2.8	QTH-410	147.25
.5000	-	1/4-18 NPT	1.2500	2.8	QTH-610	147.25
.5000	-	1/4-18 NPT	32 mm	2.8	QTHM-832	147.25

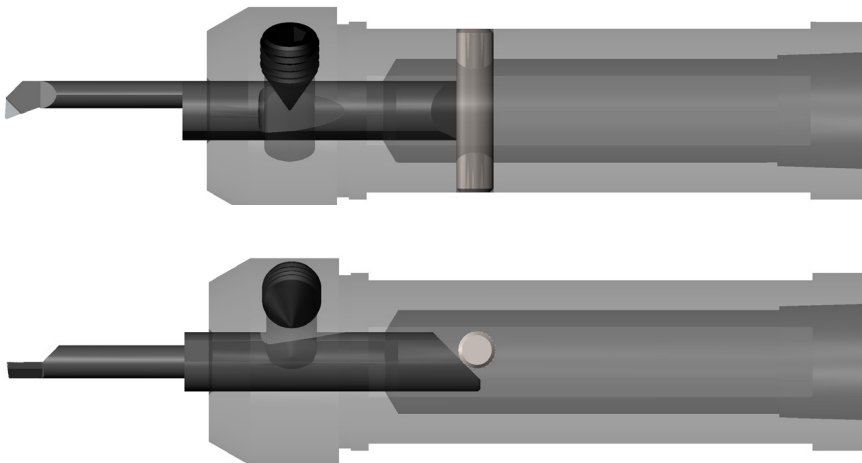

See pg 29-32 for replacement parts and accessories

QTHL / QTHML

Quick Change Holders
Headed Holder – Long Length



- Quick change, long length tool holder designed for applications requiring an extended reach
- Proprietary Micro-Quik quick change system maximizes productivity through reliable accuracy and locational repeatability
- Unique “3 point” locking and locating system ensures axial and radial tool repeatability, tip-to-tip consistency, and part-to-part accuracy
- 4 alignment flats allow for multiple tool engagements and holder orientation flexibility
- Holder plumbed for NPT coolant connection
- Heat treated and black oxide coated for durability and corrosion resistance
- Tool holder includes: hex wrench, QC-1 locating/locking screw
- Precision manufactured in the USA

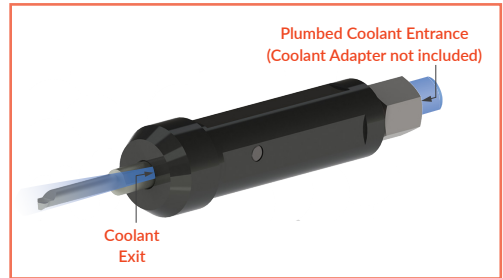

Quick Change – Holders

Internal Diameter	Head Diameter	Plumbed Thread	Shank Diameter	Overall Length	Tool Holder	
D1 $+0.0005''$ $-0.0000''$	D3 $+0.003''$ $-0.003''$		D2 $-0.0003''$ $-0.0008''$ $-0.008mm$ $-0.20mm$	L1	Tool #	Price
.1875	.750	1/8-27 NPT	12 mm	5.8	QTHM-312L	169.90
.1875	.750	1/8-27 NPT	.5000	5.8	QTH-85L	169.90
.1875	.750	1/8-27 NPT	.6250	5.8	QTH-105L	181.20
.1875	.750	1/8-27 NPT	16 mm	5.8	QTHM-316L	181.20
.1875	.875	1/4-18 NPT	.7500	5.8	QTH-205L	192.55
.1875	.875	1/4-18 NPT	20 mm	5.8	QTHM-320L	192.55
.1875	1.062	1/4-18 NPT	22 mm	5.8	QTHM-322L	192.55
.1875	1.062	1/4-18 NPT	1.0000	5.8	QTH-405L	192.55
.1875	1.250	1/4-18 NPT	25 mm	5.8	QTHM-325L	192.55
.1875	-	1/4-18 NPT	1.2500	5.8	QTH-605L	192.55
.1875	-	1/4-18 NPT	32 mm	5.8	QTHM-332L	192.55
.2500	.750	1/8-27 NPT	12 mm	5.8	QTHM-412L	169.90
.2500	.750	1/8-27 NPT	.5000	5.8	QTH-86L	169.90
.2500	.750	1/8-27 NPT	.6250	5.8	QTH-106L	181.20
.2500	.750	1/8-27 NPT	16 mm	5.8	QTHM-416L	181.20
.2500	.875	1/4-18 NPT	.7500	5.8	QTH-206L	192.55
.2500	.875	1/4-18 NPT	20 mm	5.8	QTHM-420L	192.55
.2500	1.062	1/4-18 NPT	22 mm	5.8	QTHM-422L	192.55
.2500	1.062	1/4-18 NPT	1.0000	5.8	QTH-406L	192.55
.2500	1.250	1/4-18 NPT	25 mm	5.8	QTHM-425L	192.55
.2500	-	1/4-18 NPT	1.2500	5.8	QTH-606L	192.55
.2500	-	1/4-18 NPT	32 mm	5.8	QTHM-432L	192.55

Continued on next page

Quick Change Holders

Headed Holder – Long Length (cont.)

QTHL / QTHML

Continued from previous page

Internal Diameter	Head Diameter	Plumbed Thread	Shank Diameter	Overall Length	Tool Holder	
					Tool #	Price
D1 $^{+.0005"}_{-.0000"}$	D3 $^{+.003"}_{-.003"}$		D2 $^{-.0003"}_{-.0008"}$ $^{-.008mm}_{-.020mm}$	L1		
.3125	.875	1/8-27 NPT	.6250	5.8	QTH-107L	181.20
.3125	.875	1/8-27 NPT	16 mm	5.8	QTHM-516L	181.20
.3125	.875	1/8-27 NPT	.7500	5.8	QTH-207L	192.55
.3125	.875	1/4-18 NPT	20 mm	5.8	QTHM-520L	192.55
.3125	1.062	1/4-18 NPT	22 mm	5.8	QTHM-522L	192.55
.3125	1.062	1/4-18 NPT	1.0000	5.8	QTH-407L	192.55
.3125	1.250	1/4-18 NPT	25 mm	5.8	QTHM-525L	192.55
.3125	-	1/4-18 NPT	1.2500	5.8	QTH-607L	192.55
.3125	-	1/4-18 NPT	32 mm	5.8	QTHM-532L	192.55
.3750	1.000	1/8-27 NPT	.6250	5.8	QTH-108L	181.20
.3750	1.000	1/8-27 NPT	16 mm	5.8	QTHM-616L	181.20
.3750	1.000	1/4-18 NPT	.7500	5.8	QTH-208L	192.55
.3750	1.000	1/4-18 NPT	20 mm	5.8	QTHM-620L	192.55
.3750	1.062	1/4-18 NPT	22 mm	5.8	QTHM-622L	192.55
.3750	1.062	1/4-18 NPT	1.0000	5.8	QTH-408L	192.55
.3750	1.250	1/4-18 NPT	25 mm	5.8	QTHM-625L	192.55
.3750	-	1/4-18 NPT	1.2500	5.8	QTH-608L	192.55
.3750	-	1/4-18 NPT	32 mm	5.8	QTHM-632L	192.55
.5000	1.062	1/4-18 NPT	.7500	5.8	QTH-210L	192.55
.5000	1.062	1/4-18 NPT	20 mm	5.8	QTHM-820L	192.55
.5000	1.062	1/4-18 NPT	22 mm	5.8	QTHM-822L	192.55
.5000	1.062	1/4-18 NPT	1.0000	5.8	QTH-410L	192.55
.5000	1.250	1/4-18 NPT	25 mm	5.8	QTHM-825L	192.55
.5000	-	1/4-18 NPT	1.2500	5.8	QTH-610L	192.55
.5000	-	1/4-18 NPT	32 mm	5.8	QTHM-832L	192.55

Quick Change – Holders

QDH / QDS / QDSM

Quick Change Holders
Double Ended Modular

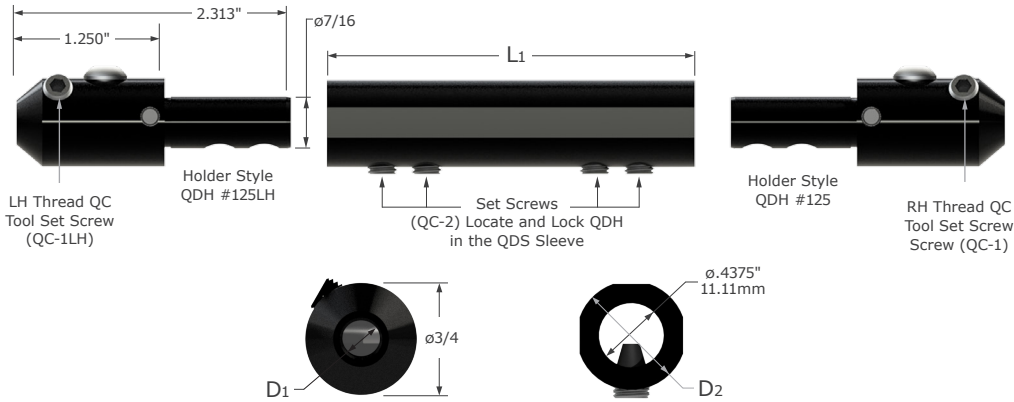

Quick Change - Holders

- Quick change tool holder designed for use in twin spindle and Y-axis tooling block locations
- Proprietary Micro-Quik quick change system maximizes productivity through reliable accuracy and locational repeatability
- Unique “3 point” locking and locating system ensures axial and radial tool repeatability, tip-to-tip consistency, and part-to-part accuracy
- 4 alignment flats allow for multiple tool engagements and holder orientation flexibility
- Assemble unit prior to installation to reduce setup time
- Left and right holder design orients set screws on the same side as operator for easy access
- Left hand head has left hand threaded set screw
- Coolant delivered via external coolant port
- Heat treated and black oxide coated for durability and corrosion resistance
- Sleeve includes: hex wrench, locating/locking screw
- Tool holder includes: hex wrench, locating/locking screw, porting plug, straight coolant adapter
- Precision manufactured in the USA

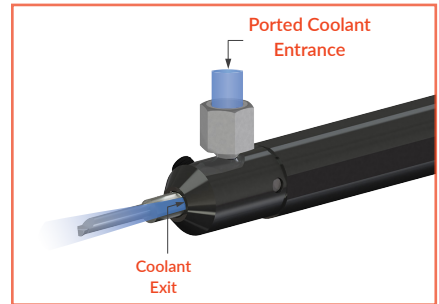

Sleeve Diameter	Length of Sleeve	Sleeve		Internal Diameter	Ported Thread	Right Hand Tool Holder		Left Hand Tool Holder						
		Tool #	Price			Tool #	Price	Tool #	Price					
D2 -.0003" -.0008" -.008mm -.020mm	L1	Tool #	Price	D1 +.0005" -.0000"		Tool #	Price	Tool #	Price					
				.1875						1/4-28 HP	QDH-3125	125.60	QDH-3125LH	125.60
				.2500						1/4-28 HP	QDH-4125	125.60	QDH-4125LH	125.60
.7500	2.5	QDS-750-2.5	136.50	.3125	1/4-28 HP	QDH-5125	125.60	QDH-5125LH	125.60					
				.1875	1/4-28 HP	QDH-3125	125.60	QDH-3125LH	125.60					
				.2500	1/4-28 HP	QDH-4125	125.60	QDH-4125LH	125.60					
.7500	3.1	QDS-750-3.1	141.95	.3125	1/4-28 HP	QDH-5125	125.60	QDH-5125LH	125.60					
				.1875	1/4-28 HP	QDH-3125	125.60	QDH-3125LH	125.60					
				.2500	1/4-28 HP	QDH-4125	125.60	QDH-4125LH	125.60					
20 mm	64 mm	QDSM-20-64	136.50	.3125	1/4-28 HP	QDH-5125	125.60	QDH-5125LH	125.60					
				.1875	1/4-28 HP	QDH-3125	125.60	QDH-3125LH	125.60					
				.2500	1/4-28 HP	QDH-4125	125.60	QDH-4125LH	125.60					
20 mm	79 mm	QDSM-20-79	141.95	.3125	1/4-28 HP	QDH-5125	125.60	QDH-5125LH	125.60					
				.1875	1/4-28 HP	QDH-3125	125.60	QDH-3125LH	125.60					
				.2500	1/4-28 HP	QDH-4125	125.60	QDH-4125LH	125.60					
22 mm	64 mm	QDSM-22-64	141.95	.3125	1/4-28 HP	QDH-5125	125.60	QDH-5125LH	125.60					
				.1875	1/4-28 HP	QDH-3125	125.60	QDH-3125LH	125.60					
				.2500	1/4-28 HP	QDH-4125	125.60	QDH-4125LH	125.60					

Continued on next page

See pg 29-32 for replacement parts and accessories

Quick Change Holders

Double Ended Modular (cont.)

QDH / QDS / QDSM

Continued from previous page

Quick Change - Holders

Sleeve Diameter D2 -.0003" -.0008" -.008mm -.020mm	Length of Sleeve L1	Sleeve		Internal Diameter D1 +.0005" -.0000"	Ported Thread	Right Hand Tool Holder		Left Hand Tool Holder	
		Tool #	Price			Tool #	Price	Tool #	Price
22 mm	79 mm	QDSM-22-79	147.40	.1875	1/4-28 HP	QDH-3125	125.60	QDH-3125LH	125.60
				.2500	1/4-28 HP	QDH-4125	125.60	QDH-4125LH	125.60
				.3125	1/4-28 HP	QDH-5125	125.60	QDH-5125LH	125.60
25 mm	64 mm	QDSM-25-64	147.40	.1875	1/4-28 HP	QDH-3125	125.60	QDH-3125LH	125.60
				.2500	1/4-28 HP	QDH-4125	125.60	QDH-4125LH	125.60
				.3125	1/4-28 HP	QDH-5125	125.60	QDH-5125LH	125.60
1.0000	2.500	QDS-1.00-2.5	147.40	.1875	1/4-28 HP	QDH-3125	125.60	QDH-3125LH	125.60
				.2500	1/4-28 HP	QDH-4125	125.60	QDH-4125LH	125.60
				.3125	1/4-28 HP	QDH-5125	125.60	QDH-5125LH	125.60
1.0000	3.100	QDS-1.00-3.1	158.35	.1875	1/4-28 HP	QDH-3125	125.60	QDH-3125LH	125.60
				.2500	1/4-28 HP	QDH-4125	125.60	QDH-4125LH	125.60
					1/4-28 HP	QDH-5125	125.60	QDH-5125LH	125.60

Technical Resources on Micro100.com

Find Simulation Files, Speeds & Feeds, Torque Recommendations, Programs, Blogs, and more at micro100.com/resources

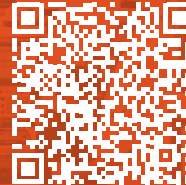

QT

Quick Change Holders

PSC Holders

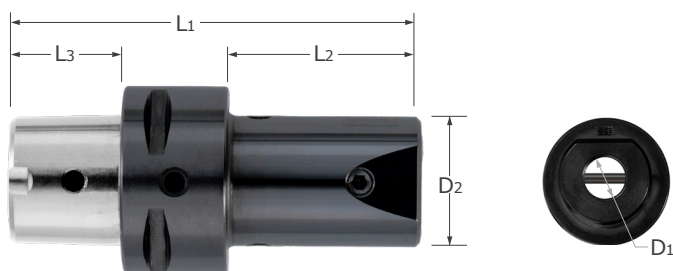

- PSC holder design combines Capto® compatible connection with proprietary Micro-Quik quick change system
- PSC flange designed for use on lathes with or without an automatic tool changer
- Short head length accommodates smaller work envelopes and provides maximum rigidity
- ID threaded for use with coolant adapter
- Proprietary Micro-Quik quick change system maximizes productivity through reliable accuracy and locational repeatability
- Unique “3 point” locking and locating system ensures axial and radial tool repeatability , tip-to-tip consistency, and part-to-part accuracy
- Heat treated for added durability
- Black oxide coated on all non-ground surfaces for corrosion resistance
- Tool holder includes: hex wrench, locating/locking screw

	Shank Type	Internal Diameter	Head Length	Head Diameter	Flange Length	Overall Length	Coolant Adapter Thread	Locating Locking Screw	Tool Holder	
		D1 $\begin{matrix} +.0005" \\ -.0000" \end{matrix}$	L2	D2	L3	L1			Tool #	Price
NEW	C3	.1875	1.134	.866	.591	2.473	M12 x 1.5	40315	QT-187-C3	349.00
NEW	C3	.2500	1.340	.866	.591	2.679	M12 x 1.5	40315	QT-250-C3	349.00
NEW	C3	.3125	1.309	.866	.591	2.647	M12 x 1.5	40316	QT-312-C3	349.00
NEW	C3	.3750	1.278	.866	.591	2.616	M12 x 1.5	40316	QT-375-C3	349.00
NEW	C3	.5000	1.528	.984	.591	2.867	M12 x 1.5	40316	QT-500-C3	349.00
NEW	C4	.1875	1.134	.866	.787	2.867	M14 x 1.5	40315	QT-187-C4	349.00
NEW	C4	.2500	1.340	.866	.787	3.072	M14 x 1.5	40315	QT-250-C4	349.00
NEW	C4	.3125	1.309	.866	.787	3.041	M14 x 1.5	40316	QT-312-C4	349.00
NEW	C4	.3750	1.278	.866	.787	3.010	M14 x 1.5	40316	QT-375-C4	349.00
NEW	C4	.5000	1.528	.984	.787	3.260	M14 x 1.5	40316	QT-500-C4	349.00

Quick Change Holders

Star Swiss Machines – SR-10J

Quick Change – Holders

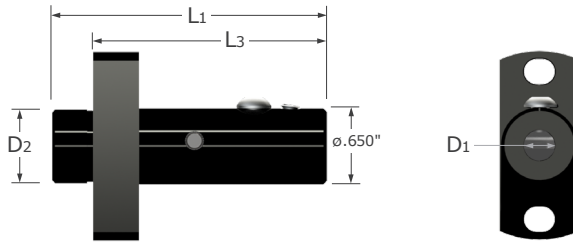

- Quick change tool holder designed for use in Star Swiss machine model SR-10J
- Proprietary Micro-Quik quick change system maximizes productivity through reliable accuracy and locational repeatability
- Designed for use with .1875", .2500", and .3125" diameter quick change tools
- Qualify with quick change centerline indicating tool (QI)
- Unique "3 point" locking and locating system ensures axial and radial tool repeatability, tip-to-tip consistency, and part-to-part accuracy
- Coolant delivered via external coolant port
- Heat treated and black oxide coated for durability and corrosion resistance
- Tool holder includes: hex wrench, locating/locking screw, porting plug, straight porting adapter
- Precision manufactured in the USA

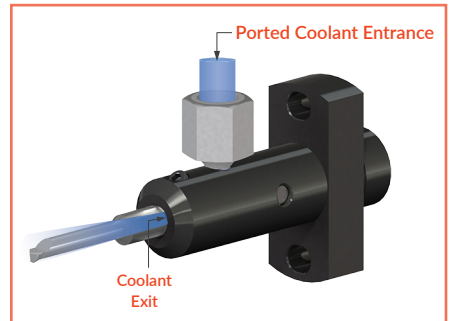

Internal Diameter	Overall Reach	Shank Diameter	Overall Length	Ported Thread	Locating/Locking Screw	Tool Holder	
						Tool #	Price
D1 ^{+ .0005"} _{- .0000"}	L3	D2	L1				
.1875	1.956	16 mm	2.350	1/4-28 HP	40316	QZST-316L-SR10J	271.90
.2500	1.956	16 mm	2.350	1/4-28 HP	40317	QZST-416L-SR10J	271.90
.3125	1.956	16 mm	2.350	1/4-28 HP	40317	QZST-516L-SR10J	271.90

See pgpage 28 for Centerline Indicating Tool

See pg 29-32 for replacement parts and accessories

QZST

Quick Change Holders
Star Swiss Machines – SR-20

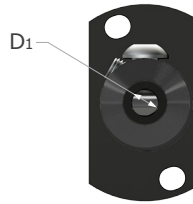
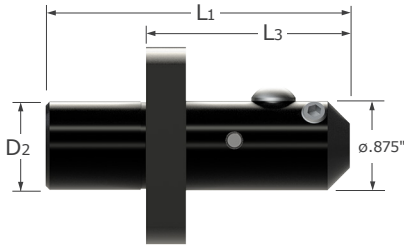

- Quick change tool holder designed for use in Star Swiss machine models SR-20, SB-16, SB-20R, SR-10J, SR-20J/JN, SR-20R, SR-20RIV, SR-32J/JN, SW-12R11, and SV-20R
- Proprietary Micro-Quik quick change system maximizes productivity through reliable accuracy and locational repeatability
- Designed for use with .1875", .2500", and .3125" diameter quick change tools
- Qualify with quick change centerline indicating tool (QI)
- Unique "3 point" locking and locating system ensures axial and radial tool repeatability, tip-to-tip consistency, and part-to-part accuracy
- Coolant delivered via external coolant port
- Heat treated and black oxide coated for durability and corrosion resistance
- Tool holder includes: hex wrench, QC-1 locating/locking screw, porting plug, straight coolant adapter
- Precision manufactured in the USA

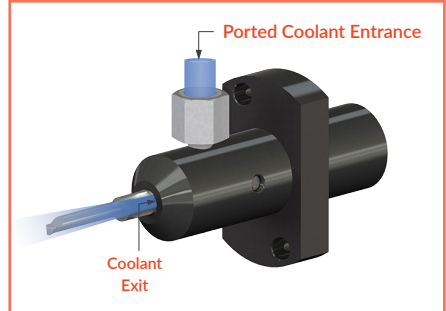

Quick Change – Holders

Internal Diameter	Overall Reach	Shank Diameter	Overall Length	Ported Thread	Tool Holder	
$D_1 \begin{smallmatrix} +.0005" \\ -.0000" \end{smallmatrix}$	L_3	D_2	L_1		Tool #	Price
.1875	1.400	22 mm	2.384	1/4-28 HP	QZST-322-SR20	282.80
.1875	2.000	22 mm	2.984	1/4-28 HP	QZST-322L-SR20	282.80
.2500	1.400	22 mm	2.384	1/4-28 HP	QZST-422-SR20	282.80
.2500	2.000	22 mm	2.984	1/4-28 HP	QZST-422L-SR20	282.80
.3125	1.400	22 mm	2.384	1/4-28 HP	QZST-522-SR20	282.80
.3125	2.000	22 mm	2.984	1/4-28 HP	QZST-522L-SR20	282.80

See pg page 28 for Centerline Indicating Tool
See pg 29-32 for replacement parts and accessories

Quick Change Holders

Star Swiss Machines – SR-20RIV

Quick Change – Holders

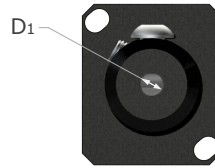
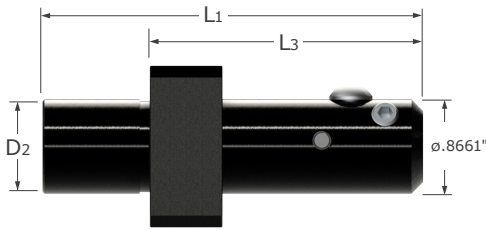

- Quick change tool holder designed for use in Star Swiss machine models SB-12/20R and SR-20RIV
- Proprietary Micro-Quik quick change system maximizes productivity through reliable accuracy and locational repeatability
- Designed for use with .1875", .2500", and .3125" diameter quick change tools
- Qualify with quick change centerline indicating tool (QI)
- Unique "3 point" locking and locating system ensures axial and radial tool repeatability, tip-to-tip consistency, and part-to-part accuracy
- Coolant delivered via external coolant port
- Heat treated and black oxide coated for durability and corrosion resistance
- Tool holder includes: hex wrench, QC-1 locating/locking screw, porting plug, straight coolant adapter
- Precision manufactured in the USA

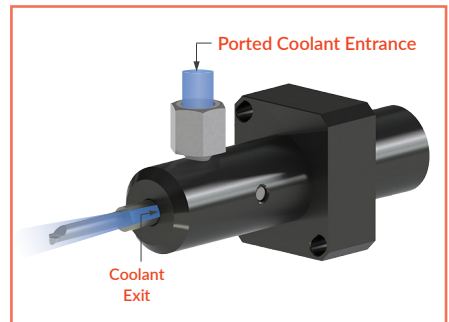

Internal Diameter	Overall Reach	Shank Diameter	Overall Length	Ported Thread	Tool Holder	
					Tool #	Price
D1 $\begin{matrix} +.0005" \\ -.0000" \end{matrix}$	L3	D2	L1			
.1875	2.510	22 mm	3.494	1/4-28 HP	QZST-322L-SR20RIV	282.80
.2500	2.510	22 mm	3.494	1/4-28 HP	QZST-422L-SR20RIV	282.80
.3125	2.510	22 mm	3.494	1/4-28 HP	QZST-522L-SR20RIV	282.80

See pg page 28 for Centerline Indicating Tool
 See pg 29-32 for replacement parts and accessories

QZST

Quick Change Holders
Star Swiss Machines – SW-20

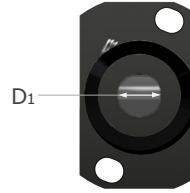
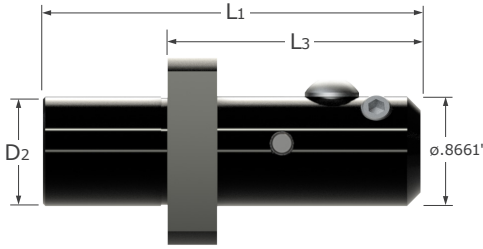

- Quick change tool holder designed for use in Star Swiss machine model SW20
- Proprietary Micro-Quik quick change system maximizes productivity through reliable accuracy and locational repeatability
- Designed for use with .1875", .2500", and .3125" diameter quick change tools
- Qualify with quick change centerline indicating tool (QI)
- Unique "3 point" locking and locating system ensures axial and radial tool repeatability, tip-to-tip consistency, and part-to-part accuracy
- Coolant delivered via external coolant port
- Heat treated and black oxide coated for durability and corrosion resistance
- Tool holder includes: hex wrench, QC-1 locating/locking screw, porting plug, straight coolant adapter
- Precision manufactured in the USA

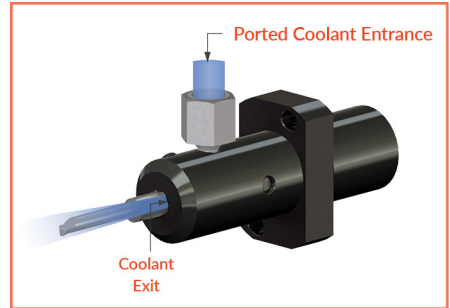

Internal Diameter	Overall Reach	Shank Diameter	Overall Length	Ported Thread	Tool Holder	
					Tool #	Price
D1 ^{+0.0005"} _{-.0000"}	L3	D2	L1			
.1875	2.000	22 mm	2.984	1/4-28 HP	QZST-322L-SW20	282.80
.2500	2.000	22 mm	2.984	1/4-28 HP	QZST-422L-SW20	282.80
.3125	2.000	22 mm	2.984	1/4-28 HP	QZST-522L-SW20	282.80

See pg page 28 for Centerline Indicating Tool
See pg 29-32 for replacement parts and accessories

Quick Change Holders

Grinding Holder – Square



- Square shank holder designed to enable repeatable grinding of custom tool profiles on quick change blanks
- Optimized for use with proprietary half round (QSP) and full round (QSR) quick change blanks
- Proprietary Micro-Quik quick change system maximizes productivity through reliable accuracy and locational repeatability
- Heat treated and black oxide coated for durability and corrosion resistance
- Tool holder includes: hex wrench, locating/locking screw
- Precision manufactured in the USA

Internal Diameter	Head Diameter	Square Shank	Overall Length	Tool Holder	
				Tool #	Price
D1 $\begin{matrix} +.0005" \\ -.0000" \end{matrix}$	D3 $\begin{matrix} +.005" \\ -.005" \end{matrix}$	A $\begin{matrix} +.0000" \\ -.0010" \end{matrix}$	L1		
.1875	.750	.5000	4.8	QSG-187-500	158.35
.1875	1.063	.7500	4.8	QSG-187-750	174.70
.2500	.750	.5000	4.8	QSG-250-500	158.35
.2500	1.063	.7500	4.8	QSG-250-750	174.70
.3125	.875	.5000	4.8	QSG-312-500	158.35
.3125	1.063	.7500	4.8	QSG-312-750	174.70
.3750	1.063	.7500	4.8	QSG-375-750	174.70
.5000	1.063	.7500	4.8	QSG-500-750	174.70

See pg 29-32 for replacement parts and accessories

Quick Change Holders

Centerline Indicating Tool

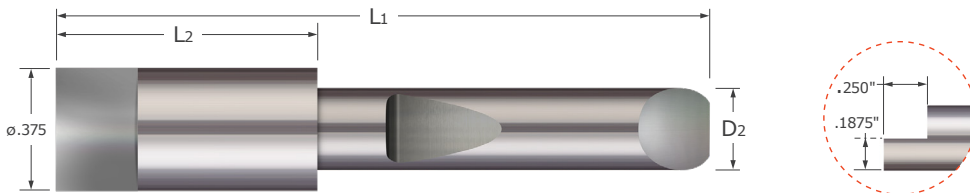

- Designed to accurately indicate centerline when using quick change holders
- Proprietary Micro-Quik quick change system maximizes productivity through reliable accuracy and locational repeatability
- Precision ground .375" flat provides a wide area for accurate and easy indicating during set up and post crash
- Precision manufactured in the USA

Shank Diameter	Body Length	Overall Length	Uncoated	
			Tool #	Price
D2 (h6)	L2 $\begin{matrix} +.000" \\ -.015" \end{matrix}$	L1		
.1875	1.000	2.0	QI-187	118.55
.2500	.800	2.0	QI-250	118.55
.3125	.800	2.0	QI-312	118.55

Quick Change Holder Parts Coolant Accessories

- Coolant adapters engineered to connect to both high pressure and low pressure with NPT and JIC-4 fittings
- Plumbed and ported accessories can be used together to allow for proper connection
- Sold individually or as packages of 10

	Accessory Type	Compatibility	Coolant Access Type	Holder Thread	Coolant Supply Thread	Single		Package of 10	
						Tool #	Price	Tool #	Price
	Straight Coolant Adapter	Fits: QTH, QTHL, QTHM, QTS, QTSP, QTSPL	Plumbed	1/8-27 NPT	JIC 4	40301	4.70	41301	39.00
	Straight Coolant Adapter	Fits: QTH, QTHL, QTHM, QTS, QTSP, QTSPL	Plumbed	1/4-18 NPT	JIC 4	40302	4.70	41302	39.00
	Straight Coolant Adapter	Fits: QTH, QTHL, QTHM, QTS, QTSP, QTSPL	Plumbed	3/8-18 NPT	JIC 4	40303	6.75	41303	54.10
	Straight Coolant Adapter	Fits: QTH, QTHL, QTS, QTSP, QTSPL	Plumbed	1/4-18 NPT	1/8-27 NPT	40311	6.75	41311	54.10
	Straight Coolant Adapter	Fits: QTH, QTHL, QTS, QTSP, QTSPL	Plumbed	3/8-18 NPT	1/8-27 NPT	40312	6.75	41312	54.10
	90° Coolant Adapter	Fits: QTH, QTHL, QTHM, QTS, QTSP, QTSPL	Plumbed	1/8-27 NPT	JIC 4	40304	8.00	41304	65.00
	90° Coolant Adapter	Fits: QTH, QTHL, QTHM, QTS, QTSP, QTSPL	Plumbed	1/4-18 NPT	JIC 4	40305	8.00	41305	65.00
	90° Coolant Adapter	Fits: QTH, QTHL, QTHM, QTS, QTSP, QTSPL	Plumbed	3/8-18 NPT	JIC 4	40306	8.00	41306	65.00
	90° Coolant Adapter	Fits: QTH, QTHL, QTHM, QTS, QTSP, QTSPL	Plumbed	1/4-18 NPT	1/8-27 NPT	40307	11.00	41307	90.50
	NPT Coolant Reducer	Fits: QTH, QTHL, QTHM, QTS, QTSP, QTSPL	Plumbed	1/4-18 NPT	1/8-27 NPT	40308	4.70	41308	39.00

Continued on next page



Quick Change Holder Parts

Coolant Accessories (cont.)

Continued from previous page

	Accessory Type	Compatibility	Coolant Access Type	Holder Thread	Coolant Supply Thread	Single		Package of 10	
						Tool #	Price	Tool #	Price
	NPT Coolant Reducer	Fits: QTH, QTHL, QTHM, QTS, QTSP, QTSPL	Plumbed	3/8-18 NPT	1/8-27 NPT	40309	6.75	41309	54.10
	Plumbed Plug	Fits: QTH, QTHL, QTHM, QTS, QTSP, QTSPL	Plumbed	1/8-27 NPT	-	40197	3.40	41197	28.10
	Plumbed Plug	Fits: QTH, QTHL, QTHM, QTS, QTSP, QTSPL	Plumbed	1/4-18 NPT	-	40198	3.40	41198	28.10
	Plumbed Plug	Fits: QTH, QTHL, QTHM, QTS, QTSP, QTSPL	Plumbed	3/8-18 NPT	-	40221	3.40	41221	28.10
	High Pressure Coolant Fitting	Fits: QZST, QDH, QTSP, QTSPL	Ported	1/4-28 HP	1/8-27 NPT	QN-1	6.75	QN-10	54.10
	1.28" Coolant Extension	Fits: QZST, QDH, QTSP, QTSPL	Ported	1/4-28 HP	1/4-28 HP	40199	6.50	41199	54.10
	45° Coolant Adapter	Fits: QZST, QDH, QTSP, QTSPL	Ported	1/4-28 HP	1/8-27 NPT	40313	6.75	41313	54.10
	90° Coolant Adapter	Fits: QZST, QDH, QTSP, QTSPL	Ported	1/4-28 HP	1/8-27 NPT	40314	6.75	41314	54.10
	Button Head Screw (Port Plug)	Fits: QDH, QZST / Hex Key not stocked for this item	Ported	1/4-28 HP	-	QC-5	1.15	QC-50	10.00
	Port Plug	Fits: QTSP, QTSPL	Ported	1/4-28 HP	-	40278	1.15	41278	9.50
	Hex Wrench	Fits: 40278 Porting Plug	Ported	-	-	40249	1.15	41249	10.00

Quick Change - Holder Parts

QC

Quick Change Holder Parts

Accessories

- Hardware and support tools for Micro 100 quick change tool holders
- Sold individually or as packages of 10

Image	Accessory Type	Compatibility	Single		Package of 10	
			Tool #	Price	Tool #	Price
	Locating / Locking Screw (Right Hand Threads)	Fits: QTH, QTHM, QZST, QSG, QDH Requires: QHT-1 Hex Key	QC-1	3.80	QC-10	27.05
	Locating / Locking Screw	Fits: QDH Requires: QHT-1 Hex Key	QC-1LH	11.00	QC-10LH	97.35
	Locating / Locking Screw	See QTS, QTSP, QTSL, QTSPL tables for compatibility	40208	1.15	41208	9.50
	Locating / Locking Screw	See QTS, QTSP, QTSL, QTSPL tables for compatibility	40215	1.15	41215	9.50
	Locating / Locking Screw	See QTS, QTSP, QTSL, QTSPL tables for compatibility	40216	1.15	41216	9.50
	Locating / Locking Screw	See QTS, QTSP, QTSPL, QTSL, QZST-SR10J tables for compatibility	40317	1.15	41317	9.50
	Locating / Locking Screw	See QTS, QTSP, QTSPL, QTSL, QZST-SR10J tables for compatibility	40316	1.15	41316	9.50
	Locating / Locking Screw	See QTS, QTSP, QTSPL, QTSL, QZST-SR10J tables for compatibility	40315	1.15	41315	9.50
	Locating / Locking Screw	See QTS, QTSP, QTSPL, QTSL, QZST-SR10J tables for compatibility	40279	1.15	41279	9.50

Quick Change - Holder Parts

Continued on next page







Quick Change Parts

QC

Accessories (cont.)

Continued from previous page

Quick Change – Holder Parts

Accessory Type	Compatibility	Single		Package of 10	
		Tool #	Price	Tool #	Price
 <p>(Left Hand Threads) Locating / Locking Screw</p>	<p>Fits: QDS, QDSM Requires: QHT-1 Hex Key</p>	QC-2	3.80	QC-20	27.05
 <p>Locating / Locking Screw</p>	<p>Fits: QZST-SR10J Requires: 3/32" Hex Key</p>	QC-6	1.15	QC-60	10.00
 <p>Hex Wrench</p>	<p>Fits: QC-3, QC-4 Locking Screws</p>	QHK-1	1.15	QHK-10	10.00
 <p>Hex Wrench</p>	<p>Fits: QC-6 Socket Set Screws</p>	QHK-2	1.15	QHK-20	10.00
 <p>Hex Wrench</p>	<p>Fits: 40208, 40215, 40216, Locating / Locking Screws</p>	40213	1.15	41213	10.00
 <p>T Style Handle Hex Wrench</p>	<p>Fits: QC-1, QC-1LH, QC-2 Locating / Locking Screws</p>	QHT-1	6.05	QHT-10	48.65

TH / THM / THMA

Standard Holders

Headed Holders - Standard Length

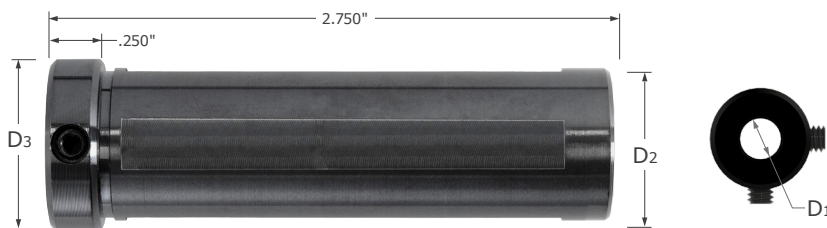

- Tool Holder optimized for use with Micro100 standard shank tools in turning applications
- Head allows for consistent length when seated against the tooling block.
- 4 alignment flats allow for multiple tool engagements and holder orientations
- Tools can be set at any length in the holder, allowing for maximum rigidity to reduce chatter and harmonics during machining
- Heat treated and black oxide coated for durability and corrosion resistance
- Tool holder includes: hex wrench, locating/locking screw
- Precision manufactured in the USA

	Internal Diameter		Head Diameter	Shank Diameter	Locating Locking Screw	Tool Holder	
	D1 $+.0005"$ $-.0000"$	decimal equiv.	D3 $+.005"$ $-.005"$ $+.127mm$ $-.127mm$	D2 $-.0003"$ $-.0008"$ $-.008mm$ $-.020mm$		Tool #	Price
	3 mm	.1181	15 mm	12 mm	40239	THM-312	77.95
	3 mm	.1181	19 mm	16 mm	40239	THM-316	77.95
	3 mm	.1181	25 mm	20 mm	40287	THM-320	86.00
NEW	.1250	.1250	15 mm	12 mm	40239	THMA-412	98.00
	.1250	.1250	.625	.5000	40211	TH-84	74.95
NEW	.1250	.1250	19 mm	16 mm	40239	THMA-416	98.00
	.1250	.1250	.750	.6250	40263	TH-104	74.95
	.1250	.1250	.875	.7500	40284	TH-204	82.70
	.1250	.1250	25 mm	20 mm	40287	THMA-420	86.00
	.1250	.1250	27 mm	22 mm	40287	THMA-422	86.00
	.1250	.1250	32 mm	25 mm	40286	THMA-425	102.05
	.1250	.1250	1.250	1.0000	40285	TH-404	98.10
	4 mm	.1575	15 mm	12 mm	40283	THM-412	77.95
	4 mm	.1575	19 mm	16 mm	40239	THM-416	77.95
	4 mm	.1575	25 mm	20 mm	40287	THM-420	86.00
NEW	.1875	.1875	15 mm	12 mm	40283	THMA-512	98.00
	.1875	.1875	.625	.5000	40211	TH-85	74.95
NEW	.1875	.1875	19 mm	16 mm	40239	THMA-516	98.00
	.1875	.1875	.750	.6250	40263	TH-105	74.95
	.1875	.1875	.875	.7500	40284	TH-205	82.70
	.1875	.1875	25 mm	20 mm	40287	THMA-520	86.00
	.1875	.1875	27 mm	22 mm	40287	THMA-522	86.00
	.1875	.1875	32 mm	25 mm	40286	THMA-525	102.05
	.1875	.1875	1.250	1.0000	40285	TH-405	98.10
	6 mm	.2362	15 mm	12 mm	40283	THM-612	77.95
	6 mm	.2362	19 mm	16 mm	40239	THM-616	77.95
	6 mm	.2362	25 mm	20 mm	40287	THM-620	86.00

Continued on next page

See pg 38 for replacement parts and accessories

Standard Holders

TH / THM / THMA

Headed Holders - Standard Length (cont.)

Continued from previous page

Standard Holders

Internal Diameter		Head Diameter	Shank Diameter	Locating Locking Screw	Tool Holder	
D ₁ ^{+ .0005"} _{- .0000"}	decimal equiv.	D ₃ ^{+ .005"} _{- .005"} ^{+ .127mm} _{- .127mm}	D ₂ ^{- .0003"} _{- .0008"} ^{- .008mm} _{- .020mm}		Tool #	Price
.2500	.2500	15 mm	12 mm	40283	THMA-612	98.00
.2500	.2500	.625	.5000	40211	TH-86	74.95
.2500	.2500	19 mm	16 mm	40239	THMA-616	98.00
.2500	.2500	.750	.6250	40211	TH-106	74.95
.2500	.2500	.875	.7500	40263	TH-206	82.70
.2500	.2500	25 mm	20 mm	40287	THMA-620	86.00
.2500	.2500	27 mm	22 mm	40287	THMA-622	86.00
.2500	.2500	32 mm	25 mm	40286	THMA-625	102.05
.2500	.2500	1.250	1.0000	40285	TH-406	98.10
.3125	.3125	15 mm	12 mm	40283	THMA-712	98.00
.3125	.3125	.625	.5000	40211	TH-87	74.95
.3125	.3125	19 mm	16 mm	40283	THMA-716	98.00
.3125	.3125	.750	.6250	40211	TH-107	74.95
.3125	.3125	.875	.7500	40263	TH-207	82.70
.3125	.3125	25 mm	20 mm	40287	THMA-720	86.00
.3125	.3125	27 mm	22 mm	40287	THMA-722	86.00
.3125	.3125	32 mm	25 mm	40287	THMA-725	102.05
.3125	.3125	1.250	1.0000	40284	TH-407	98.10
8 mm	.3150	15 mm	12 mm	40283	THM-812	77.95
8 mm	.3150	19 mm	16 mm	40283	THM-816	77.95
8 mm	.3150	25 mm	20 mm	40287	THM-820	86.00
.3750	.3750	.625	.5000	40211	TH-88	74.95
.3750	.3750	19 mm	16 mm	40283	THMA-816	98.00
.3750	.3750	.750	.6250	40211	TH-108	74.95
.3750	.3750	.875	.7500	40211	TH-208	82.70
.3750	.3750	25 mm	20 mm	40239	THMA-820	86.00
.3750	.3750	27 mm	22 mm	40287	THMA-822	86.00
.3750	.3750	32 mm	25 mm	40287	THMA-825	102.05
.3750	.3750	1.250	1.0000	40284	TH-408	98.10
10 mm	.3937	19 mm	16 mm	40283	THM-1016	77.95
10 mm	.3937	25 mm	20 mm	40239	THM-1020	86.00
12 mm	.4724	19 mm	16 mm	40283	THM-1216	77.95
12 mm	.4724	25 mm	20 mm	40283	THM-1220	86.00
.5000	.5000	.875	.7500	40211	TH-210	82.70
.5000	.5000	1.125	1.0000	40284	TH-410	98.10

NEW

NEW

NEW

NEW

NEW

THS

Standard Holders
Straight Holders - Standard Length

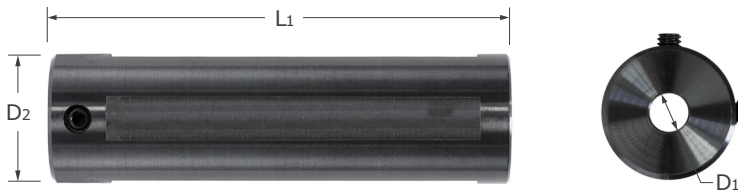

- Headless tool holder engineered for maximum versatility in any Swiss, standard lathe, or multi-function lathe
- Tool holder optimized for use with Micro 100 standard shank tools in turning applications
- 4 alignment flats allow for multiple tool engagements and holder orientations
- Heat treated and black oxide coated for durability and corrosion resistance
- Tool holder includes: hex wrench, locating/locking screw
- Precision manufactured in the USA

	Internal Diameter	Shank Diameter	Overall Length	Locating Locking Screw	Tool Holder	
	D1 $+ .0005"$ $- .0000"$	D2 $+ .0003"$ $- .0008"$ $+ .008mm$ $- .020mm$	L1		Tool #	Price
NEW	.1250	.5000	2.75	40211	THS-2-500	99.00
NEW	.1250	.6250	2.75	40211	THS-2-625	99.00
NEW	.1250	16 mm	2.75	40263	THS-2-630	104.00
NEW	.1250	.7500	2.75	40263	THS-2-750	104.00
NEW	.1250	20 mm	2.75	40263	THS-2-787	104.00
NEW	.1250	22 mm	2.75	40284	THS-2-866	104.00
NEW	.1250	25 mm	2.75	40284	THS-2-984	109.00
NEW	.1250	1.0000	2.75	40284	THS-2-1000	109.00
NEW	.1875	.5000	2.75	40211	THS-3-500	99.00
NEW	.1875	.6250	2.75	40211	THS-3-625	99.00
NEW	.1875	16 mm	2.75	40211	THS-3-630	104.00
NEW	.1875	.7500	2.75	40263	THS-3-750	104.00
NEW	.1875	20 mm	2.75	40284	THS-3-787	104.00
NEW	.1875	22 mm	2.75	40284	THS-3-866	104.00
NEW	.1875	25 mm	2.75	40284	THS-3-984	109.00
NEW	.1875	1.0000	2.75	40284	THS-3-1000	109.00
NEW	.2500	.6250	2.75	40211	THS-4-625	99.00
NEW	.2500	16 mm	2.75	40211	THS-4-630	99.00
NEW	.2500	.7500	2.75	40211	THS-4-750	104.00
NEW	.2500	20 mm	2.75	40211	THS-4-787	104.00
NEW	.2500	22 mm	2.75	40263	THS-4-866	104.00
NEW	.2500	25 mm	2.75	40284	THS-4-984	104.00
NEW	.2500	1.0000	2.75	40284	THS-4-1000	109.00

Continued on next page

Standard Holders

Straight Holders - Standard Length (cont.)

Continued from previous page

Internal Diameter	Shank Diameter	Overall Length	Locating Locking Screw	Tool Holder	
				Tool #	Price
$D_1 \begin{matrix} +.0005'' \\ -.0000'' \end{matrix}$	$D_2 \begin{matrix} +.0003'' \\ -.0008'' \\ +.008\text{mm} \\ -.020\text{mm} \end{matrix}$	L1			
.3125	.6250	2.75	40211	THS-5-625	99.00 NEW
.3125	16 mm	2.75	40211	THS-5-630	99.00 NEW
.3125	.7500	2.75	40211	THS-5-750	104.00 NEW
.3125	20 mm	2.75	40211	THS-5-787	104.00 NEW
.3125	22 mm	2.75	40263	THS-5-866	104.00 NEW
.3125	25 mm	2.75	40284	THS-5-984	104.00 NEW
.3125	1.0000	2.75	40284	THS-5-1000	109.00 NEW
.3750	.7500	2.75	40211	THS-6-750	104.00 NEW
.3750	20 mm	2.75	40211	THS-6-787	104.00 NEW
.3750	22 mm	2.75	40211	THS-6-866	104.00 NEW
.3750	25 mm	2.75	40263	THS-6-984	109.00 NEW
.3750	1.0000	2.75	40263	THS-6-1000	109.00 NEW
.5000	25 mm	2.75	40211	THS-8-984	109.00 NEW
.5000	1.0000	2.75	40211	THS-8-1000	109.00 NEW

Standard Holders

Sent Directly to Your Inbox

Valuable information about Micro 100 products and technical resources directly to your inbox. Be the first to know of newly-released tools to gain an immediate leg-up on the competition!

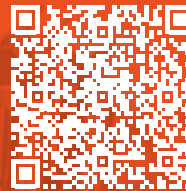

THSL

Standard Holders
Straight Holders - Long Length

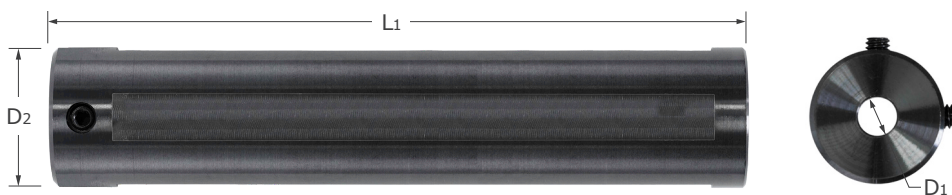

- Long length, headless tool holder designed for applications requiring an extended reach
- Headless tool holder engineered for maximum versatility in any Swiss, standard lathe, or multi-function lathe
- Tool holder optimized for use with Micro 100 standard shank tools in turning applications
- 4 alignment flats allow for multiple tool engagements and holder orientations
- Heat treated and black oxide coated for durability and corrosion resistance
- Tool holder includes: hex wrench, locating/locking screw
- Precision manufactured in the USA

	Internal Diameter	Shank Diameter	Overall zLength	Locating Locking Screw	Tool Holder	
	$D_1 \begin{smallmatrix} +.0005'' \\ -.0000'' \end{smallmatrix}$	$D_2 \begin{smallmatrix} +.0003'' \\ -.0008'' \\ +.008mm \\ -.020mm \end{smallmatrix}$	L1		Tool #	Price
NEW	.1250	.7500	5.75	40263	THSL-2-750	116.00
NEW	.1250	20 mm	5.75	40263	THSL-2-787	116.00
NEW	.1250	22 mm	5.75	40284	THSL-2-866	119.00
NEW	.1250	1.0000	5.75	40284	THSL-2-1000	122.00
NEW	.1875	.7500	5.75	40263	THSL-3-750	116.00
NEW	.1875	20 mm	5.75	40284	THSL-3-787	116.00
NEW	.1875	22 mm	5.75	40284	THSL-3-866	119.00
NEW	.1875	1.0000	5.75	40284	THSL-3-1000	122.00
NEW	.2500	.7500	5.75	40211	THSL-4-750	116.00
NEW	.2500	20 mm	5.75	40211	THSL-4-787	116.00
NEW	.2500	22 mm	5.75	40263	THSL-4-866	119.00
NEW	.2500	1.0000	5.75	40284	THSL-4-1000	122.00
NEW	.3125	.7500	5.75	40211	THSL-5-750	116.00
NEW	.3125	20 mm	5.75	40211	THSL-5-787	116.00
NEW	.3125	22 mm	5.75	40263	THSL-5-866	119.00
NEW	.3125	1.0000	5.75	40284	THSL-5-1000	122.00
NEW	.3750	.7500	5.75	40211	THSL-6-750	116.00
NEW	.3750	20 mm	5.75	40211	THSL-6-787	116.00
NEW	.3750	22 mm	5.75	40211	THSL-6-866	119.00
NEW	.3750	1.0000	5.75	40263	THSL-6-1000	122.00
NEW	.5000	1.0000	5.75	40211	THSL-8-1000	122.00





See pg 38 for replacement parts and accessories

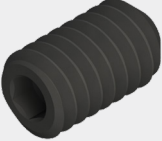
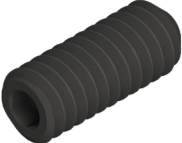
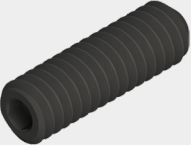

Standard Parts

Accessories

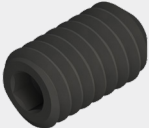
Standard Holder Parts

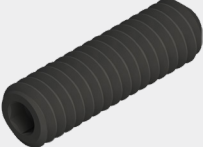
Accessory Type	Compatibility	Single		Package of 10	
		Tool #	Price	Tool #	Price
 Locating / Locking Screw	See standard holder tables for compatibility page 33-37	40211	1.15	41211	9.50
 Locating / Locking Screw		40263	1.15	41263	9.50
 Locating / Locking Screw		40284	1.15	41284	9.50
 Locating / Locking Screw		40285	1.15	41285	9.50
 Locating / Locking Screw		40283	1.15	41283	9.50
 Locating / Locking Screw		40239	1.15	41239	9.50
 Locating / Locking Screw		40287	1.15	41287	9.50
 Locating / Locking Screw		40286	1.15	41286	9.50



ERI

Taper Integrated Holders

Solid ER



- Reached ER taper integrated holder that eliminates the need for multiple spindle adapters
- Designed for Swiss and multi-function lathes
- Works with any ER holder or ER spindle in both live and static applications
- Multiple projections available
- Maximum T.I.R. of < .0002"
- Included stop screw allows for quicker tool changes
- Stop screw can be adjusted from either end of the holder

	Taper Size	ID Size	Projection	Tool Holder	
				Tool #	Price
		D1	L2		
NEW	ER08	.1250	.394	ER08I-2-394	261.60
NEW	ER08	.1250	.590	ER08I-2-590	261.60
NEW	ER11	.1250	.394	ER11I-2-394	261.60
NEW	ER11	.1250	.590	ER11I-2-590	261.60
NEW	ER11	.1250	.787	ER11I-2-787	261.60
NEW	ER16	.1250	.630	ER16I-2-630	273.60
NEW	ER16	.1250	.984	ER16I-2-984	273.60
NEW	ER16	.1875	.630	ER16I-3-630	273.60
NEW	ER16	.1875	.984	ER16I-3-984	273.60

Taper Integrated Holder Parts

Accessories

- Hardware and support tools for Micro 100 ER taper integrated tool holders
- Sold individually or as packages of 10

Accessory Type	Thread Size	Single		Package of 10		
		Tool #	Price	Tool #	Price	
 Stop Screw	M6	40810	14.50	41810	130.00	NEW
 Stop Screw	M8	40811	17.50	41811	160.00	NEW
 Locking Screw	M3	40812	2.20	41812	17.70	NEW
 Locking Screw	M4	40813	2.20	41813	17.70	NEW

Taper Integrated Holder Parts

ER

ER Collets
Metric ID

- Collets with metric ID sizes and ranges
- Can be utilized in live or static applications
- Maximum T.I.R. of .0004"
- High polished finish helps resist oxidation



	Taper Size	ID Size	Clamp Range	Tool Holder	
				Tool #	Price
		D1			
NEW	ER08	1.0 mm	0.5-1.0 mm	ER08-039	14.00
NEW	ER08	1.5 mm	1.0-1.5 mm	ER08-059	14.00
NEW	ER08	2.0 mm	1.5-2.0 mm	ER08-079	14.00
NEW	ER08	2.5 mm	2.0-2.5 mm	ER08-098	14.00
NEW	ER08	3.0 mm	2.5-3.0 mm	ER08-118	14.00
NEW	ER08	3.5 mm	3.0-3.5 mm	ER08-138	14.00
NEW	ER08	4.0 mm	3.5-4.0 mm	ER08-157	14.00
NEW	ER08	4.5 mm	4.0-4.5 mm	ER08-177	14.00
NEW	ER08	5.0 mm	4.5-5.0 mm	ER08-197	14.00
NEW	ER11	1.0 mm	0.5-1.0 mm	ER11-039	15.50
NEW	ER11	1.5 mm	1.0-1.5 mm	ER11-059	15.50
NEW	ER11	2.0 mm	1.5-2.0 mm	ER11-079	15.50
NEW	ER11	2.5 mm	2.0-2.5 mm	ER11-098	15.50
NEW	ER11	3.0 mm	2.5-3.0 mm	ER11-118	15.50
NEW	ER11	3.5 mm	3.0-3.5 mm	ER11-138	15.50
NEW	ER11	4.0 mm	3.5-4.0 mm	ER11-157	15.50
NEW	ER11	4.5 mm	4.0-4.5 mm	ER11-177	15.50
NEW	ER11	5.0 mm	4.5-5.0 mm	ER11-197	15.50
NEW	ER11	5.5 mm	5.0-5.5 mm	ER11-217	15.50
NEW	ER11	6.0 mm	5.5-6.0 mm	ER11-236	15.50
NEW	ER11	6.5 mm	6.0-6.5 mm	ER11-256	15.50
NEW	ER11	7.0 mm	6.5-7.0 mm	ER11-276	15.50
NEW	ER16	1.0 mm	0.5-1.0 mm	ER16-039	16.90
NEW	ER16	1.5 mm	1.0-1.5 mm	ER16-059	16.90
NEW	ER16	2.0 mm	1.5-2.0 mm	ER16-079	16.90
NEW	ER16	2.5 mm	1.5-2.5 mm	ER16-098	16.90
NEW	ER16	3.0 mm	2.0-3.0 mm	ER16-118	16.90
NEW	ER16	3.5 mm	2.5-3.5 mm	ER16-138	16.90
NEW	ER16	4.0 mm	3.0-4.0 mm	ER16-157	16.90
NEW	ER16	4.5 mm	3.5-4.5 mm	ER16-177	16.90
NEW	ER16	5.0 mm	4.0-5.0 mm	ER16-197	16.90
NEW	ER16	5.5 mm	4.5-5.5 mm	ER16-217	16.90
NEW	ER16	6.0 mm	5.0-6.0 mm	ER16-236	16.90

Continued on next page

Collets



ER Collets

Metric ID (cont.)

ER

Continued from previous page

Taper Size	ID Size	Clamp Range	Tool Holder	
			Tool #	Price
	D ₁			
ER16	6.5 mm	5.5-6.5 mm	ER16-256	16.90
ER16	7.0 mm	6.0-7.0 mm	ER16-276	16.90
ER16	7.5 mm	6.5-7.5 mm	ER16-295	16.90
ER16	8.0 mm	7.0-8.0 mm	ER16-315	16.90
ER16	8.5 mm	7.5-8.5 mm	ER16-335	16.90
ER16	9.0 mm	8.0-9.0 mm	ER16-354	16.90
ER16	9.5 mm	8.5-9.5 mm	ER16-374	16.90
ER16	10.0 mm	9.0-10.0 mm	ER16-394	16.90
ER16	10.5 mm	9.5-10.5 mm	ER16-413	16.90

NEW
NEW
NEW
NEW
NEW
NEW
NEW
NEW
NEW
NEW

Collets



Build & Send Shopping Carts Directly to Your Distributor or Purchasing Agent

Create Your Micro100 Account Today at Micro100.com

ER

ER Collets
Standard ID

- Collets with standard ID sizes and ranges
- Can be utilized in live or static applications
- Maximum T.I.R. of .0004"
- High polished finish helps resist oxidation



	Taper Size	ID Size	Clamp Range	ER Collet	
				Tool #	Price
		D1			
NEW	ER08	.0625	.043-.062	ER08-062	14.00
NEW	ER08	.1250	.086-.125	ER08-125	14.00
NEW	ER08	.1875	.148-.187	ER08-187	14.00
NEW	ER11	.0625	.043-.062	ER11-062	15.50
NEW	ER11	.0937	.054-.093	ER11-093	15.50
NEW	ER11	.1250	.086-.125	ER11-125	15.50
NEW	ER11	.1562	.117-.156	ER11-156	15.50
NEW	ER11	.1875	.148-.187	ER11-187	15.50
NEW	ER11	.2187	.179-.218	ER11-218	15.50
NEW	ER11	.2500	.211-.250	ER11-250	15.50
NEW	ER11	.2811	.242-.281	ER11-281	15.50
NEW	ER16	.0625	.043-.062	ER16-062	16.90
NEW	ER16	.0937	.054-.093	ER16-093	16.90
NEW	ER16	.1250	.086-.125	ER16-125	16.90
NEW	ER16	.1562	.117-.156	ER16-156	16.90
NEW	ER16	.1875	.148-.187	ER16-187	16.90
NEW	ER16	.2187	.179-.218	ER16-218	16.90
NEW	ER16	.2500	.211-.250	ER16-250	16.90
NEW	ER16	.2811	.242-.281	ER16-281	16.90
NEW	ER16	.3125	.273-.312	ER16-312	16.90
NEW	ER16	.3437	.304-.343	ER16-343	16.90
NEW	ER16	.3750	.336-.375	ER16-375	16.90
NEW	ER16	.4062	.367-.406	ER16-406	16.90

ER Collets Sets



- Collet sets available in either standard or metric ID sizes and ranges
- Can be utilized in live or static applications
- Maximum T.I.R. of .0004"
- High polished finish helps resist oxidation

Collets

Taper Size	ID Size	Collet Count	Clamp Range	Set		
				Tool #	Price	
ER08	Metric	9	0.5-5.0 mm	ER08M-1	118.00	NEW
ER11	Standard	7	.043-.250	ER11S-1	99.00	NEW
ER11	Metric	13	0.5-7.0 mm	ER11M-1	192.00	NEW
ER16	Standard	10	.054-.375	ER16S-1	159.00	NEW
ER16	Metric	10	0.5-10.0 mm	ER16M-1	159.00	NEW

TURNING TOOLS

Internal Diameter (ID) - Quick Change

Quick Change - Boring Tools	46
Quick Change - Profiling Tools	62
Quick Change - Grooving Tools	68
Quick Change - Threading Tools	89
Quick Change - Holemaking Tools	96
Quick Change - Blanks	101

Internal Diameter (ID) - Standard

Standard - Boring Tools	103
Standard - Profiling Tools	127
Standard - Grooving Tools	133
Standard - Threading Tools	158

Internal Diameter (ID) - Indexable

Indexable - Boring Bars, Boring	172
Indexable - Boring Bars, Facing	174
Indexable - Boring Bars, Profiling	175

Outside Diameter (OD) - Indexable

Indexable - Tool Holders, Chamfering & Turning	176
Indexable - Tool Holders, Facing & Turning	177
Indexable - Tool Holders, Profiling	180

Outside Diameter (OD) - Brazed

Brazed - Box Turning Tools	181
Brazed - Forming Tools	182
Brazed - Grooving Tools	190
Brazed - Threading Tools	195
Brazed - Screw Machine Tools	196
Brazed - Cut Off Tools	198

Quick Change - Boring Tools

QMBB

Right Hand - Sharp - Miniature

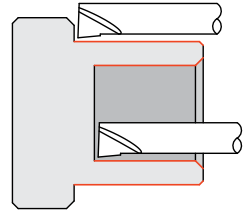
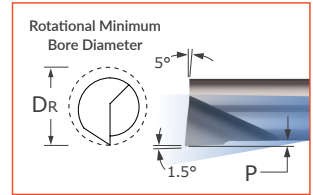
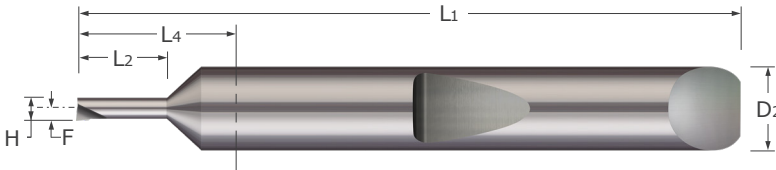

Quick Change - Boring Tools

- Designed for facing and boring applications in bores .015" and larger
- Polished split face for improved edge retention and chip evacuation while reducing galling
- Split face geometry provides optimal edge strength
- On center neck design allows for static and live/rotating applications
- Coolant fed enabled shank design
- Sharp corner profile
- Proprietary Micro-Quik quick change system maximizes productivity through reliable accuracy and locational repeatability
- AlTiN coated option provides added lubricity and increased wear resistance in difficult to machine materials
- Solid carbide
- CNC ground in the USA

Head Width	Rotational Minimum Bore Dia.	Max. Bore Depth	Projection	Length From Holder	Centerline Offset	Shank Diameter	Overall Length	Uncoated		AlTiN Coated	
								Tool #	Price	Tool #	Price
H	D _R	L ₂ ^{+0.030"} / _{-.000"}	P	L ₄	F	D ₂ (h6)	L ₁				
.0135	.0150	.050	.0015	.590	.0075	.1875	1.5	QMBB-015050	45.75	QMBB-015050X	49.65
.0135	.0150	.075	.0015	.590	.0075	.1875	1.5	QMBB-015075	45.75	QMBB-015075X	50.50
.0180	.0200	.050	.0020	.590	.0100	.1875	1.5	QMBB-020050	45.75	QMBB-020050X	50.50
.0180	.0200	.075	.0020	.590	.0100	.1875	1.5	QMBB-020075	45.75	QMBB-020075X	49.65
.0180	.0200	.100	.0020	.590	.0100	.1875	1.5	QMBB-020100	45.75	QMBB-020100X	50.50
.0225	.0250	.050	.0025	.590	.0125	.1875	1.5	QMBB-025050	40.30	QMBB-025050X	45.05
.0225	.0250	.075	.0025	.590	.0125	.1875	1.5	QMBB-025075	40.30	QMBB-025075X	45.05
.0225	.0250	.100	.0025	.590	.0125	.1875	1.5	QMBB-025100	40.30	QMBB-025100X	44.00
.0225	.0250	.125	.0025	.590	.0125	.1875	1.5	QMBB-025125	40.30	QMBB-025125X	45.05
.0275	.0300	.075	.0025	.590	.0150	.1875	1.5	QMBB-030075	40.30	QMBB-030075X	45.05
.0275	.0300	.100	.0025	.590	.0150	.1875	1.5	QMBB-030100	40.30	QMBB-030100X	44.00
.0275	.0300	.125	.0025	.590	.0150	.1875	1.5	QMBB-030125	40.30	QMBB-030125X	45.05
.0275	.0300	.150	.0025	.590	.0150	.1875	1.5	QMBB-030150	40.30	QMBB-030150X	45.05
.0320	.0350	.075	.0030	.590	.0175	.1875	1.5	QMBB-035075	40.30	QMBB-035075X	45.05
.0320	.0350	.100	.0030	.590	.0175	.1875	1.5	QMBB-035100	40.30	QMBB-035100X	44.00
.0320	.0350	.150	.0030	.590	.0175	.1875	1.5	QMBB-035150	40.30	QMBB-035150X	44.00
.0320	.0350	.200	.0030	.590	.0175	.1875	1.5	QMBB-035200	40.30	QMBB-035200X	45.05
.0365	.0400	.100	.0035	.590	.0200	.1875	1.5	QMBB-040100	40.30	QMBB-040100X	45.05
.0365	.0400	.150	.0035	.590	.0200	.1875	1.5	QMBB-040150	40.30	QMBB-040150X	44.00
.0365	.0400	.200	.0035	.590	.0200	.1875	1.5	QMBB-040200	40.30	QMBB-040200X	44.00
.0405	.0450	.100	.0045	.590	.0225	.1875	1.5	QMBB-045100	40.30	QMBB-045100X	45.05
.0405	.0450	.150	.0045	.590	.0225	.1875	1.5	QMBB-045150	40.30	QMBB-045150X	44.00
.0405	.0450	.200	.0045	.590	.0225	.1875	1.5	QMBB-045200	40.30	QMBB-045200X	44.00
.0440	.0500	.100	.0060	.590	.0250	.1875	1.5	QMBB-050100	31.50	QMBB-050100X	36.25
.0440	.0500	.150	.0060	.590	.0250	.1875	1.5	QMBB-050150	31.50	QMBB-050150X	34.85
.0440	.0500	.200	.0060	.590	.0250	.1875	1.5	QMBB-050200	31.50	QMBB-050200X	34.85
.0440	.0500	.300	.0060	.590	.0250	.1875	1.5	QMBB-050300	31.50	QMBB-050300X	34.85
.0525	.0600	.150	.0075	.590	.0300	.1875	1.5	QMBB-060150	31.50	QMBB-060150X	34.85
.0525	.0600	.200	.0075	.590	.0300	.1875	1.5	QMBB-060200	31.50	QMBB-060200X	34.85
.0525	.0600	.300	.0075	.590	.0300	.1875	1.5	QMBB-060300	31.50	QMBB-060300X	34.85
.0525	.0600	.400	.0075	.590	.0300	.1875	1.5	QMBB-060400	31.50	QMBB-060400X	34.85
.0525	.0600	.500	.0075	.590	.0300	.1875	1.5	QMBB-060500	31.50	QMBB-060500X	34.85

Continued on next page

See pg 14-28 for quick change holder options

QMBB

Quick Change – Boring Tools
Right Hand – Sharp - Miniature (cont.)

Continued from previous page

Head Width	Rotational Minimum Bore Dia.	Max. Bore Depth	Projection	Length From Holder	Centerline Offset	Shank Diameter	Overall Length	Uncoated		AITIN Coated	
								Tool #	Price	Tool #	Price
H	D _R		P	L ₄	F		L ₁				
.0625	.0700	.150	.0075	.590	.0350	.1875	1.5	QMBB-070150	31.50	QMBB-070150X	34.85
.0625	.0700	.200	.0075	.590	.0350	.1875	1.5	QMBB-070200	31.50	QMBB-070200X	34.85
.0625	.0700	.300	.0075	.590	.0350	.1875	1.5	QMBB-070300	31.50	QMBB-070300X	34.85
.0625	.0700	.400	.0075	.590	.0350	.1875	1.5	QMBB-070400	31.50	QMBB-070400X	34.85
.0625	.0700	.500	.0075	.590	.0350	.1875	1.5	QMBB-070500	31.50	QMBB-070500X	34.85
.0700	.0800	.150	.0100	.590	.0400	.1875	1.5	QMBB-080150	31.50	QMBB-080150X	34.85
.0700	.0800	.200	.0100	.590	.0400	.1875	1.5	QMBB-080200	31.50	QMBB-080200X	34.85
.0700	.0800	.300	.0100	.590	.0400	.1875	1.5	QMBB-080300	31.50	QMBB-080300X	34.85
.0700	.0800	.500	.0100	.590	.0400	.1875	1.5	QMBB-080500	31.50	QMBB-080500X	34.85
.0700	.0800	.600	.0100	1.090	.0400	.1875	2.0	QMBB-080600	31.50	QMBB-080600X	34.85
.0800	.0900	.200	.0100	.590	.0450	.1875	1.5	QMBB-090200	31.50	QMBB-090200X	36.25
.0800	.0900	.300	.0100	.590	.0450	.1875	1.5	QMBB-090300	31.50	QMBB-090300X	34.85
.0800	.0900	.500	.0100	.590	.0450	.1875	1.5	QMBB-090500	31.50	QMBB-090500X	34.85
.0800	.0900	.700	.0100	1.090	.0450	.1875	2.0	QMBB-090700	31.50	QMBB-090700X	34.85
.0875	.1000	.200	.0125	.590	.0500	.1875	1.5	QMBB-100200	31.50	QMBB-100200X	36.25
.0875	.1000	.300	.0125	.590	.0500	.1875	1.5	QMBB-100300	31.50	QMBB-100300X	34.85
.0875	.1000	.500	.0125	.590	.0500	.1875	1.5	QMBB-100500	31.50	QMBB-100500X	34.85
.0875	.1000	.700	.0125	1.090	.0500	.1875	2.0	QMBB-100700	31.50	QMBB-100700X	34.85
.0875	.1000	.800	.0125	1.090	.0500	.1875	2.0	QMBB-100800	31.50	QMBB-100800X	34.85

Quick Change – Boring Tools

Quick Change – Boring Tools

Right Hand – Sharp

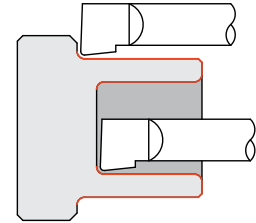
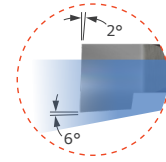
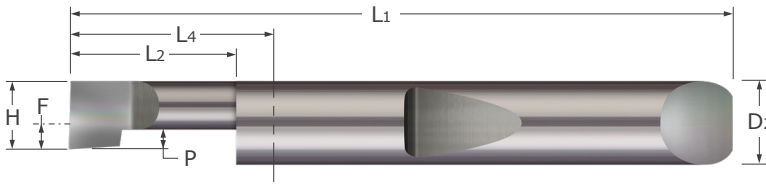

Quick Change – Boring Tools

- Designed for facing and boring applications in bores .055" and larger
- Polished split face for improved edge retention and chip evacuation while reducing galling
- Split face geometry provides optimal edge strength
- Coolant fed enabled shank design
- Sharp corner profile
- Proprietary Micro-Quik quick change system maximizes productivity through reliable accuracy and locational repeatability
- AlTiN coated option provides added lubricity and increased wear resistance in difficult to machine materials
- Solid carbide ■ CNC ground in the USA

Head Width	Min. Bore Diameter*	Max. Bore Depth	Proj.	Length From Holder	Centerline Offset	Shank Diameter	Overall Length	Uncoated		AlTiN Coated	
								Tool #	Price	Tool #	Price
H		L2 + ^{+0.030"} _{-.000"}	P	L4	F	D2 (h6)	L1				
.0500	.0550	.150	.013	.590	-.0438	.1875	1.5	QBB-050150	31.50	QBB-050150X	34.85
.0500	.0550	.200	.013	.590	-.0438	.1875	1.5	QBB-050200	31.50	QBB-050200X	34.85
.0500	.0550	.300	.013	.590	-.0438	.1875	1.5	QBB-050300	31.50	QBB-050300X	34.85
.0500	.0550	.400	.013	.590	-.0438	.1875	1.5	QBB-050400	31.50	QBB-050400X	34.85
.0600	.0700	.150	.015	.590	-.0338	.1875	1.5	QBB-060150	31.50	QBB-060150X	34.85
.0600	.0700	.200	.015	.590	-.0338	.1875	1.5	QBB-060200	31.50	QBB-060200X	34.85
.0600	.0700	.300	.015	.590	-.0338	.1875	1.5	QBB-060300	31.50	QBB-060300X	34.85
.0600	.0700	.400	.015	.590	-.0338	.1875	1.5	QBB-060400	31.50	QBB-060400X	34.85
.0600	.0700	.500	.015	.590	-.0338	.1875	1.5	QBB-060500	31.50	QBB-060500X	34.85
.0700	.0800	.150	.015	.590	-.0238	.1875	1.5	QBB-070150-000	31.50	QBB-070150-000X	36.25
.0700	.0800	.200	.015	.590	-.0238	.1875	1.5	QBB-070200-000	31.50	QBB-070200-000X	36.25
.0700	.0800	.300	.015	.590	-.0238	.1875	1.5	QBB-070300-000	31.50	QBB-070300-000X	36.25
.0800	.0900	.150	.020	.590	-.0138	.1875	1.5	QBB-080150-000	31.50	QBB-080150-000X	36.25
.0800	.0900	.200	.020	.590	-.0138	.1875	1.5	QBB-080200	31.50	QBB-080200X	34.85
.0800	.0900	.300	.020	.590	-.0138	.1875	1.5	QBB-080300	31.50	QBB-080300X	34.85
.0800	.0900	.400	.020	.590	-.0138	.1875	1.5	QBB-080400-000	31.50	QBB-080400-000X	36.25
.0800	.0900	.500	.020	.590	-.0138	.1875	1.5	QBB-080500	31.50	QBB-080500X	34.85
.0800	.0900	.600	.020	1.090	-.0138	.1875	2.0	QBB-080600	31.50	QBB-080600X	34.85
.0900	.1000	.150	.020	.590	-.0038	.1875	1.5	QBB-090150-000	33.40	QBB-090150-000X	38.15
.0900	.1000	.200	.020	.590	-.0038	.1875	1.5	QBB-090200-000	33.40	QBB-090200-000X	38.15
.0900	.1000	.300	.020	.590	-.0038	.1875	1.5	QBB-090300-000	33.40	QBB-090300-000X	38.15
.0900	.1000	.400	.020	.590	-.0038	.1875	1.5	QBB-090400-000	33.40	QBB-090400-000X	38.15
.0900	.1000	.500	.020	.590	-.0038	.1875	1.5	QBB-090500-000	33.40	QBB-090500-000X	38.15
.1000	.1100	.150	.025	.590	.0063	.1875	1.5	QBB-100150-000	33.40	QBB-100150-000X	38.15
.1000	.1100	.200	.025	.590	.0063	.1875	1.5	QBB-100200	33.40	QBB-100200X	36.80
.1000	.1100	.300	.025	.590	.0063	.1875	1.5	QBB-100300	33.40	QBB-100300X	36.80

*Suggested Minimum Bore Diameter to accommodate chip evacuation and retract clearance in static (not live) applications.

Continued on next page

See pg 14-28 for quick change holder options

See pg 46 for miniature sizes

For better chip control and freer cutting action, see Helical Back Rake and Top Rake Chipbreaker tools on pgs 56-59

QBB

Quick Change – Boring Tools

Right Hand – Sharp (cont.)

Continued from previous page

Head Width	Min. Bore Diameter*	Max. Bore Depth	Proj.	Length From Holder	Centerline Offset	Shank Diameter	Overall Length	Uncoated		AlTiN Coated	
								Tool #	Price	Tool #	Price
H	L ₂ ^{+0.030"} _{-.000"}	P	L ₄	F	D ₂ (h6)	L ₁	Tool #	Price	Tool #	Price	
.1000	.1100	.400	.025	.590	.0063	.1875	1.5	QBB-100400-000	33.40	QBB-100400-000X	38.15
.1000	.1100	.500	.025	.590	.0063	.1875	1.5	QBB-100500	33.40	QBB-100500X	36.80
.1000	.1100	.600	.025	1.090	.0063	.1875	2.0	QBB-100600-000	34.75	QBB-100600-000X	39.50
.1000	.1100	.700	.025	1.090	.0063	.1875	2.0	QBB-100700	33.40	QBB-100700X	36.80
.1100	.1220	.150	.028	.590	.0163	.1875	1.5	QBB-110150-000	33.40	QBB-110150-000X	38.15
.1100	.1220	.200	.028	.590	.0163	.1875	1.5	QBB-110200-000	33.40	QBB-110200-000X	38.15
.1100	.1220	.300	.028	.590	.0163	.1875	1.5	QBB-110300-000	33.40	QBB-110300-000X	37.90
.1100	.1220	.400	.028	.590	.0163	.1875	1.5	QBB-110400-000	33.40	QBB-110400-000X	38.15
.1100	.1220	.500	.028	.590	.0163	.1875	1.5	QBB-110500-000	33.40	QBB-110500-000X	38.15
.1100	.1220	.600	.028	1.090	.0163	.1875	2.0	QBB-110600-000	34.75	QBB-110600-000X	39.50
.1100	.1220	.700	.028	1.090	.0163	.1875	2.0	QBB-110700-000	34.75	QBB-110700-000X	39.50
.1200	.1320	.250	.030	.590	.0263	.1875	1.5	QBB-120250-000	33.40	QBB-120250-000X	37.90
.1200	.1320	.350	.030	.590	.0263	.1875	1.5	QBB-120350-000	33.40	QBB-120350-000X	37.90
.1200	.1320	.500	.030	.590	.0263	.1875	1.5	QBB-120500-000	33.40	QBB-120500-000X	37.90
.1200	.1320	.600	.030	1.090	.0263	.1875	2.0	QBB-120600-000	34.75	QBB-120600-000X	39.50
.1200	.1320	.700	.030	1.090	.0263	.1875	2.0	QBB-120700-000	34.75	QBB-120700-000X	39.50
.1200	.1320	.800	.030	1.090	.0263	.1875	2.0	QBB-120800-000	34.75	QBB-120800-000X	39.50
.1400	.1520	.250	.035	.590	.0463	.1875	1.5	QBB-140250-000	33.40	QBB-140250-000X	37.90
.1400	.1520	.400	.035	.590	.0463	.1875	1.5	QBB-140400-000	33.40	QBB-140400-000X	37.90
.1400	.1520	.500	.035	.590	.0463	.1875	1.5	QBB-140500-000	33.40	QBB-140500-000X	37.90
.1400	.1520	.600	.035	1.090	.0463	.1875	2.0	QBB-140600-000	34.75	QBB-140600-000X	39.50
.1400	.1520	.700	.035	1.090	.0463	.1875	2.0	QBB-140700-000	34.75	QBB-140700-000X	39.50
.1400	.1520	.750	.035	1.090	.0463	.1875	2.0	QBB-140750-000	34.75	QBB-140750-000X	39.50
.1400	.1520	.800	.035	1.090	.0463	.1875	2.0	QBB-140800-000	34.75	QBB-140800-000X	39.50
.1400	.1520	.900	.035	1.090	.0463	.1875	2.0	QBB-140900-000	34.75	QBB-140900-000X	39.50
.1600	.1760	.250	.040	.590	.0663	.1875	1.5	QBB-160250-000	33.40	QBB-160250-000X	38.15
.1600	.1760	.400	.040	.590	.0663	.1875	1.5	QBB-160400-000	33.40	QBB-160400-000X	37.90
.1600	.1760	.500	.040	.590	.0663	.1875	1.5	QBB-160500-000	33.40	QBB-160500-000X	37.90
.1600	.1760	.600	.040	1.090	.0663	.1875	2.0	QBB-160600-000	33.40	QBB-160600-000X	37.90
.1600	.1760	.750	.040	1.090	.0663	.1875	2.0	QBB-160750-000	34.75	QBB-160750-000X	39.50
.1600	.1760	.900	.040	1.090	.0663	.1875	2.0	QBB-160900-000	34.75	QBB-160900-000X	39.50
.1600	.1760	1.000	.040	1.090	.0663	.1875	2.0	QBB-1601000-000	33.40	QBB-1601000-000X	37.90
.1800	.1960	.350	.045	.853	.0550	.2500	2.0	QBB-180350-000	37.45	QBB-180350-000X	43.10
.1800	.1960	.500	.045	.853	.0550	.2500	2.0	QBB-180500-000	37.45	QBB-180500-000X	43.10
.1800	.1960	.600	.045	.853	.0550	.2500	2.0	QBB-180600-000	37.45	QBB-180600-000X	43.10
.1800	.1960	.750	.045	.853	.0550	.2500	2.0	QBB-180750-000	37.45	QBB-180750-000X	43.10
.1800	.1960	.900	.045	1.353	.0550	.2500	2.5	QBB-180900-000	38.85	QBB-180900-000X	44.90
.1800	.1960	1.000	.045	1.353	.0550	.2500	2.5	QBB-1801000-000	38.85	QBB-1801000-000X	44.90
.1800	.1960	1.250	.045	1.353	.0550	.2500	2.5	QBB-1801250-000	38.85	QBB-1801250-000X	44.90
.1800	.1960	1.500	.045	1.853	.0550	.2500	3.0	QBB-1801500-000	40.35	QBB-1801500-000X	46.40

*Suggested Minimum Bore Diameter to accommodate chip evacuation and retract clearance in static (not live) applications.

Continued on next page

See pg 14-28 for quick change holder options

See pg 46 for miniature sizes

For better chip control and freer cutting action, see Helical Back Rake and Top Rake Chipbreaker tools on pgs 56-59

Quick Change – Boring Tools

Right Hand – Sharp (cont.)

Continued from previous page

Quick Change – Boring Tools

Head Width	Min. Bore Diameter*	Max. Bore Depth	Proj.	Length From Holder	Centerline Offset	Shank Diameter	Overall Length	Uncoated		AlTiN Coated	
								Tool #	Price	Tool #	Price
H		L ₂ ^{+0.030"} _{-.000"}	P	L ₄	F	D ₂ (h6)	L ₁				
.2000	.2160	.400	.050	.853	.0750	.2500	2.0	QBB-200400-000	37.45	QBB-200400-000X	43.10
.2000	.2160	.500	.050	.853	.0750	.2500	2.0	QBB-200500-000	37.45	QBB-200500-000X	43.10
.2000	.2160	.600	.050	.853	.0750	.2500	2.0	QBB-200600-000	37.45	QBB-200600-000X	43.10
.2000	.2160	.700	.050	.853	.0750	.2500	2.0	QBB-200700-000	37.45	QBB-200700-000X	43.10
.2000	.2160	.750	.050	.853	.0750	.2500	2.0	QBB-200750-000	37.45	QBB-200750-000X	43.10
.2000	.2160	1.000	.050	1.353	.0750	.2500	2.5	QBB-2001000-000	37.45	QBB-2001000-000X	43.50
.2000	.2160	1.300	.050	1.353	.0750	.2500	2.5	QBB-2001300-000	37.45	QBB-2001300-000X	43.50
.2300	.2500	.400	.058	.853	.0738	.3125	2.0	QBB-230400-000	48.05	QBB-230400-000X	54.90
.2300	.2500	.500	.058	.853	.0738	.3125	2.0	QBB-230500-000	48.05	QBB-230500-000X	54.90
.2300	.2500	.600	.058	.853	.0738	.3125	2.0	QBB-230600-000	48.05	QBB-230600-000X	54.90
.2300	.2500	.700	.058	.853	.0738	.3125	2.0	QBB-230700-000	48.05	QBB-230700-000X	54.90
.2300	.2500	.750	.058	.853	.0738	.3125	2.0	QBB-230750-000	48.05	QBB-230750-000X	54.90
.2300	.2500	.800	.058	1.353	.0738	.3125	2.5	QBB-230800-000	49.45	QBB-230800-000X	56.70
.2300	.2500	.900	.058	1.353	.0738	.3125	2.5	QBB-230900-000	49.45	QBB-230900-000X	56.70
.2300	.2500	1.000	.058	1.353	.0738	.3125	2.5	QBB-2301000-000	48.05	QBB-2301000-000X	55.30
.2300	.2500	1.250	.058	1.353	.0738	.3125	2.5	QBB-2301250-000	48.05	QBB-2301250-000X	55.30
.2300	.2500	1.500	.058	1.853	.0738	.3125	3.0	QBB-2301500-000	48.05	QBB-2301500-000X	55.30
.2600	.2800	.500	.065	.853	.1038	.3125	2.0	QBB-260500-000	48.05	QBB-260500-000X	54.90
.2600	.2800	.750	.065	.853	.1038	.3125	2.0	QBB-260750-000	48.05	QBB-260750-000X	54.90
.2600	.2800	1.000	.065	1.353	.1038	.3125	2.5	QBB-2601000-000	49.45	QBB-2601000-000X	56.70
.2600	.2800	1.250	.065	1.353	.1038	.3125	2.5	QBB-2601250-000	49.45	QBB-2601250-000X	56.70
.2900	.3100	.500	.073	.853	.1338	.3125	2.0	QBB-290500-000	48.05	QBB-290500-000X	54.90
.2900	.3100	.600	.073	.853	.1338	.3125	2.0	QBB-290600-000	48.05	QBB-290600-000X	54.90
.2900	.3100	.750	.073	.853	.1338	.3125	2.0	QBB-290750-000	48.05	QBB-290750-000X	54.90
.2900	.3100	.900	.073	1.353	.1338	.3125	2.5	QBB-290900-000	49.45	QBB-290900-000X	56.70
.2900	.3100	1.000	.073	1.353	.1338	.3125	2.5	QBB-2901000-000	49.45	QBB-2901000-000X	56.70
.2900	.3100	1.250	.073	1.353	.1338	.3125	2.5	QBB-2901250-000	49.45	QBB-2901250-000X	56.70
.3200	.3400	.500	.080	.853	.1325	.3750	2.0	QBB-320500-000	65.95	QBB-320500-000X	74.05
.3200	.3400	1.000	.080	1.353	.1325	.3750	2.5	QBB-3201000-000	69.70	QBB-3201000-000X	78.30
.3200	.3400	1.500	.080	1.853	.1325	.3750	3.0	QBB-3201500-000	73.25	QBB-3201500-000X	81.85

*Suggested Minimum Bore Diameter to accommodate chip evacuation and retract clearance in static (not live) applications.

See pg 14-28 for quick change holder options

See pg 46 for miniature sizes

For better chip control and freer cutting action, see Helical Back Rake and Top Rake Chipbreaker tools on pgs 56-59

QBB

Quick Change – Boring Tools
Right Hand

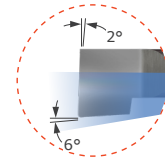
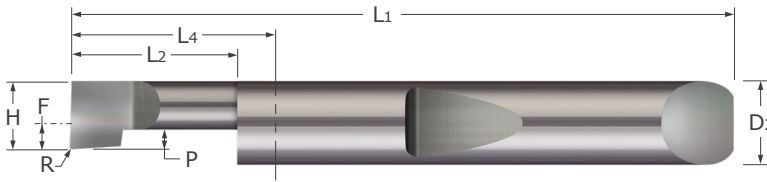

- Designed for facing and boring applications in bores .055" and larger
- Polished split face for improved edge retention and chip evacuation while reducing galling
- Split face geometry provides optimal edge strength
- Coolant fed enabled shank design
- Corner radius profile
- Proprietary Micro-Quik quick change system maximizes productivity through reliable accuracy and locational repeatability
- AlTiN coated option provides added lubricity and increased wear resistance in difficult to machine materials
- Solid carbide ■ CNC ground in the USA

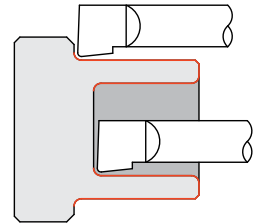

Quick Change – Boring Tools

Head Width	Min. Bore Diameter*	Max. Bore Depth	Radius	Proj.	Length From Holder	Centerline Offset	Shank Diameter	Overall Length	Uncoated		AlTiN Coated	
									Tool #	Price	Tool #	Price
H		L2	R	P	L4	F	D2 (h6)	L1				
		$^{+.030}_{-.000}$	$^{+.001}_{-.001}$									
.0500	.0550	.150	.003	.013	.590	-.0438	.1875	1.5	QBB3-050150	35.15	QBB3-050150X	39.90
.0500	.0550	.200	.003	.013	.590	-.0438	.1875	1.5	QBB3-050200	35.15	QBB3-050200X	39.90
.0500	.0550	.300	.003	.013	.590	-.0438	.1875	1.5	QBB3-050300	35.15	QBB3-050300X	39.90
.0500	.0550	.400	.003	.013	.590	-.0438	.1875	1.5	QBB3-050400	35.15	QBB3-050400X	39.90
.0600	.0700	.150	.003	.015	.590	-.0338	.1875	1.5	QBB3-060150	35.15	QBB3-060150X	39.90
.0600	.0700	.200	.003	.015	.590	-.0338	.1875	1.5	QBB3-060200	35.15	QBB3-060200X	39.90
.0600	.0700	.300	.003	.015	.590	-.0338	.1875	1.5	QBB3-060300	35.15	QBB3-060300X	39.90
.0600	.0700	.400	.003	.015	.590	-.0338	.1875	1.5	QBB3-060400	35.15	QBB3-060400X	39.90
.0600	.0700	.500	.003	.015	.590	-.0338	.1875	1.5	QBB3-060500	35.15	QBB3-060500X	39.90
.0700	.0800	.150	.003	.015	.590	-.0238	.1875	1.5	QBB3-070150	35.15	QBB3-070150X	39.90
.0700	.0800	.200	.003	.015	.590	-.0238	.1875	1.5	QBB3-070200	35.15	QBB3-070200X	39.90
.0700	.0800	.300	.003	.015	.590	-.0238	.1875	1.5	QBB3-070300	35.15	QBB3-070300X	39.90
.0800	.0900	.150	.003	.020	.590	-.0138	.1875	1.5	QBB3-080150	35.15	QBB3-080150X	39.90
.0800	.0900	.200	.003	.020	.590	-.0138	.1875	1.5	QBB3-080200	35.15	QBB3-080200X	39.90
.0800	.0900	.300	.003	.020	.590	-.0138	.1875	1.5	QBB3-080300	35.15	QBB3-080300X	39.90
.0800	.0900	.400	.003	.020	.590	-.0138	.1875	1.5	QBB3-080400	35.15	QBB3-080400X	39.90
.0800	.0900	.500	.003	.020	.590	-.0138	.1875	1.5	QBB3-080500	35.15	QBB3-080500X	39.90
.0800	.0900	.600	.003	.020	1.090	-.0138	.1875	2.0	QBB3-080600	36.50	QBB3-080600X	41.25
.0900	.1000	.150	.003	.020	.590	-.0038	.1875	1.5	QBB3-090150	35.15	QBB3-090150X	39.90
.0900	.1000	.200	.003	.020	.590	-.0038	.1875	1.5	QBB3-090200	35.15	QBB3-090200X	39.90
.0900	.1000	.300	.003	.020	.590	-.0038	.1875	1.5	QBB3-090300	35.15	QBB3-090300X	39.90
.0900	.1000	.400	.003	.020	.590	-.0038	.1875	1.5	QBB3-090400	35.15	QBB3-090400X	39.90
.0900	.1000	.500	.003	.020	.590	-.0038	.1875	1.5	QBB3-090500	35.15	QBB3-090500X	39.90
.1000	.1100	.150	.003	.025	.590	.0063	.1875	1.5	QBB3-100150	33.40	QBB3-100150X	38.15
.1000	.1100	.200	.003	.025	.590	.0063	.1875	1.5	QBB3-100200	33.40	QBB3-100200X	38.15

*Suggested Minimum Bore Diameter to accommodate chip evacuation and retract clearance in static (not live) applications.

Continued on next page

See pg 14-28 for quick change holder options

See pg 46 for miniature sizes

For better chip control and freer cutting action, see Helical Back Rake and Top Rake Chipbreaker tools on pgs 56-59

Quick Change – Boring Tools

QBB

Right Hand (cont.)

Continued from previous page

Quick Change – Boring Tools

Head Width	Min. Bore Diameter*	Max. Bore Depth	Radius	Proj.	Length From Holder	Centerline Offset	Shank Diameter	Overall Length	Uncoated		AlTiN Coated		
H	L2	$\begin{matrix} +.030" \\ -.000" \end{matrix}$	R	$\begin{matrix} +.001" \\ -.001" \end{matrix}$	P	L4	F	D2 (h6)	L1	Tool #	Price	Tool #	Price
.1000	.1100	.300	.003	.025	.590	.0063	.1875	1.5	QBB3-100300	33.40	QBB3-100300X	38.15	
.1000	.1100	.400	.003	.025	.590	.0063	.1875	1.5	QBB3-100400	33.40	QBB3-100400X	38.15	
.1000	.1100	.500	.003	.025	.590	.0063	.1875	1.5	QBB3-100500	33.40	QBB3-100500X	38.15	
.1000	.1100	.600	.003	.025	1.090	.0063	.1875	2.0	QBB3-100600	34.75	QBB3-100600X	39.50	
.1000	.1100	.700	.003	.025	1.090	.0063	.1875	2.0	QBB3-100700	34.75	QBB3-100700X	39.50	
.1100	.1220	.150	.003	.028	.590	.0163	.1875	1.5	QBB3-110150	33.40	QBB3-110150X	38.15	
.1100	.1220	.200	.003	.028	.590	.0163	.1875	1.5	QBB3-110200	33.40	QBB3-110200X	38.15	
.1100	.1220	.300	.003	.028	.590	.0163	.1875	1.5	QBB-110300	33.40	QBB-110300X	36.80	
.1100	.1220	.400	.003	.028	.590	.0163	.1875	1.5	QBB3-110400	33.40	QBB3-110400X	38.15	
.1100	.1220	.500	.003	.028	.590	.0163	.1875	1.5	QBB-110500	33.40	QBB-110500X	36.80	
.1100	.1220	.600	.003	.028	1.090	.0163	.1875	2.0	QBB3-110600	34.75	QBB3-110600X	39.50	
.1100	.1220	.700	.003	.028	1.090	.0163	.1875	2.0	QBB-110700	33.40	QBB-110700X	36.80	
.1200	.1320	.250	.003	.030	.590	.0263	.1875	1.5	QBB-120250	33.40	QBB-120250X	36.80	
.1200	.1320	.250	.005	.030	.590	.0263	.1875	1.5	QBB5-120250	33.40	QBB5-120250X	38.15	
.1200	.1320	.350	.003	.030	.590	.0263	.1875	1.5	QBB-120350	33.40	QBB-120350X	36.80	
.1200	.1320	.350	.005	.030	.590	.0263	.1875	1.5	QBB5-120350	33.40	QBB5-120350X	38.15	
.1200	.1320	.500	.003	.030	.590	.0263	.1875	1.5	QBB-120500	33.40	QBB-120500X	36.80	
.1200	.1320	.500	.005	.030	.590	.0263	.1875	1.5	QBB5-120500	33.40	QBB5-120500X	38.15	
.1200	.1320	.600	.003	.030	1.090	.0263	.1875	2.0	QBB3-120600	34.75	QBB3-120600X	39.50	
.1200	.1320	.600	.005	.030	1.090	.0263	.1875	2.0	QBB5-120600	34.75	QBB5-120600X	39.50	
.1200	.1320	.700	.003	.030	1.090	.0263	.1875	2.0	QBB-120700	33.40	QBB-120700X	36.80	
.1200	.1320	.700	.005	.030	1.090	.0263	.1875	2.0	QBB5-120700	34.75	QBB5-120700X	39.50	
.1200	.1320	.800	.003	.030	1.090	.0263	.1875	2.0	QBB-120800	33.40	QBB-120800X	36.80	
.1200	.1320	.800	.005	.030	1.090	.0263	.1875	2.0	QBB5-120800	34.75	QBB5-120800X	39.50	
.1400	.1520	.250	.003	.035	.590	.0463	.1875	1.5	QBB3-140250	33.40	QBB3-140250X	38.15	
.1400	.1520	.250	.005	.035	.590	.0463	.1875	1.5	QBB5-140250	33.40	QBB5-140250X	38.15	
.1400	.1520	.400	.003	.035	.590	.0463	.1875	1.5	QBB-140400	33.40	QBB-140400X	36.80	
.1400	.1520	.400	.005	.035	.590	.0463	.1875	1.5	QBB5-140400	33.40	QBB5-140400X	38.15	
.1400	.1520	.500	.003	.035	.590	.0463	.1875	1.5	QBB3-140500	33.40	QBB3-140500X	38.15	
.1400	.1520	.500	.005	.035	.590	.0463	.1875	1.5	QBB5-140500	33.40	QBB5-140500X	38.15	
.1400	.1520	.600	.003	.035	1.090	.0463	.1875	2.0	QBB-140600	33.40	QBB-140600X	36.80	
.1400	.1520	.600	.005	.035	1.090	.0463	.1875	2.0	QBB5-140600	34.75	QBB5-140600X	39.50	
.1400	.1520	.700	.003	.035	1.090	.0463	.1875	2.0	QBB3-140700	34.75	QBB3-140700X	39.50	
.1400	.1520	.700	.005	.035	1.090	.0463	.1875	2.0	QBB5-140700	34.75	QBB5-140700X	39.50	
.1400	.1520	.750	.003	.035	1.090	.0463	.1875	2.0	QBB3-140750	34.75	QBB3-140750X	39.50	
.1400	.1520	.750	.005	.035	1.090	.0463	.1875	2.0	QBB5-140750	34.75	QBB5-140750X	39.50	
.1400	.1520	.800	.003	.035	1.090	.0463	.1875	2.0	QBB-140800	33.40	QBB-140800X	36.80	
.1400	.1520	.800	.005	.035	1.090	.0463	.1875	2.0	QBB5-140800	34.75	QBB5-140800X	39.50	
.1400	.1520	.900	.003	.035	1.090	.0463	.1875	2.0	QBB3-140900	34.75	QBB3-140900X	39.50	
.1400	.1520	.900	.005	.035	1.090	.0463	.1875	2.0	QBB5-140900	34.75	QBB5-140900X	39.50	

*Suggested Minimum Bore Diameter to accommodate chip evacuation and retract clearance in static (not live) applications.

Continued on next page

See pg 14-28 for quick change holder options

See pg 46 for miniature sizes

For better chip control and freer cutting action, see Helical Back Rake and Top Rake Chipbreaker tools on pgs 56-59

QBB

Quick Change – Boring Tools

Right Hand (cont.)

Continued from previous page

Head Width	Min. Bore Diameter*	Max. Bore Depth	Radius	Proj.	Length From Holder	Centerline Offset	Shank Diameter	Overall Length	Uncoated		AITIN Coated	
									Tool #	Price	Tool #	Price
H	L2	$R \begin{smallmatrix} +.001'' \\ -.001'' \end{smallmatrix}$	P	L4	F	D2 (h6)	L1					
.1600	.1760	.250	.003	.040	.590	.0663	.1875	1.5	QBB3-160250	33.40	QBB3-160250X	38.15
.1600	.1760	.250	.005	.040	.590	.0663	.1875	1.5	QBB5-160250	33.40	QBB5-160250X	38.15
.1600	.1760	.400	.003	.040	.590	.0663	.1875	1.5	QBB-160400	33.40	QBB-160400X	36.80
.1600	.1760	.400	.005	.040	.590	.0663	.1875	1.5	QBB5-160400	33.40	QBB5-160400X	38.15
.1600	.1760	.500	.003	.040	.590	.0663	.1875	1.5	QBB3-160500	33.40	QBB3-160500X	38.15
.1600	.1760	.500	.005	.040	.590	.0663	.1875	1.5	QBB5-160500	33.40	QBB5-160500X	38.15
.1600	.1760	.600	.003	.040	1.090	.0663	.1875	2.0	QBB-160600	33.40	QBB-160600X	36.80
.1600	.1760	.600	.005	.040	1.090	.0663	.1875	2.0	QBB5-160600	34.75	QBB5-160600X	39.50
.1600	.1760	.700	.003	.040	1.090	.0663	.1875	2.0	QBB3-160700	34.75	QBB3-160700X	39.50
.1600	.1760	.700	.005	.040	1.090	.0663	.1875	2.0	QBB5-160700	34.75	QBB5-160700X	39.50
.1600	.1760	.750	.003	.040	1.090	.0663	.1875	2.0	QBB-160750	33.40	QBB-160750X	36.80
.1600	.1760	.750	.005	.040	1.090	.0663	.1875	2.0	QBB5-160750	34.75	QBB5-160750X	39.50
.1600	.1760	.800	.003	.040	1.090	.0663	.1875	2.0	QBB3-160800	34.75	QBB3-160800X	39.50
.1600	.1760	.800	.005	.040	1.090	.0663	.1875	2.0	QBB5-160800	34.75	QBB5-160800X	39.50
.1600	.1760	.900	.003	.040	1.090	.0663	.1875	2.0	QBB3-160900	34.75	QBB3-160900X	39.50
.1600	.1760	.900	.005	.040	1.090	.0663	.1875	2.0	QBB5-160900	34.75	QBB5-160900X	39.50
.1600	.1760	1.000	.003	.040	1.090	.0663	.1875	2.0	QBB-1601000	33.40	QBB-1601000X	36.80
.1600	.1760	1.000	.005	.040	1.090	.0663	.1875	2.0	QBB5-1601000	34.75	QBB5-1601000X	39.50
.1800	.1960	.350	.005	.045	.853	.0550	.2500	2.0	QBB5-180350	34.75	QBB5-180350X	40.40
.1800	.1960	.500	.005	.045	.853	.0550	.2500	2.0	QBB-180500	36.05	QBB-180500X	41.70
.1800	.1960	.600	.005	.045	.853	.0550	.2500	2.0	QBB5-180600	36.05	QBB5-180600X	41.70
.1800	.1960	.750	.005	.045	.853	.0550	.2500	2.0	QBB-180750	36.05	QBB-180750X	41.70
.1800	.1960	.900	.005	.045	1.353	.0550	.2500	2.5	QBB5-180900	37.35	QBB5-180900X	43.40
.1800	.1960	1.000	.005	.045	1.353	.0550	.2500	2.5	QBB-1801000	36.05	QBB-1801000X	41.80
.1800	.1960	1.250	.005	.045	1.353	.0550	.2500	2.5	QBB-1801250	36.05	QBB-1801250X	41.80
.1800	.1960	1.500	.005	.045	1.853	.0550	.2500	3.0	QBB-1801500	42.30	QBB-1801500X	48.35
.2000	.2160	.400	.005	.050	.853	.0750	.2500	2.0	QBB5-200400	36.05	QBB5-200400X	41.70
.2000	.2160	.500	.005	.050	.853	.0750	.2500	2.0	QBB-200500	36.05	QBB-200500X	41.70
.2000	.2160	.600	.005	.050	.853	.0750	.2500	2.0	QBB5-200600	36.05	QBB5-200600X	41.70
.2000	.2160	.700	.005	.050	.853	.0750	.2500	2.0	QBB5-200700	36.05	QBB5-200700X	41.70
.2000	.2160	.750	.005	.050	.853	.0750	.2500	2.0	QBB-200750	36.05	QBB-200750X	41.70
.2000	.2160	.800	.005	.050	1.353	.0750	.2500	2.5	QBB5-200800	37.35	QBB5-200800X	43.40
.2000	.2160	.900	.005	.050	1.353	.0750	.2500	2.5	QBB5-200900	37.35	QBB5-200900X	43.40
.2000	.2160	1.000	.005	.050	1.353	.0750	.2500	2.5	QBB-2001000	36.05	QBB-2001000X	41.80
.2000	.2160	1.100	.005	.050	1.353	.0750	.2500	2.5	QBB5-2001100	37.35	QBB5-2001100X	43.40
.2000	.2160	1.200	.005	.050	1.353	.0750	.2500	2.5	QBB-2001200	36.05	QBB-2001200X	41.80
.2000	.2160	1.300	.005	.050	1.853	.0750	.2500	3.0	QBB5-2001300	37.35	QBB5-2001300X	43.40
.2000	.2160	1.500	.005	.050	1.853	.0750	.2500	3.0	QBB-2001500	42.30	QBB-2001500X	48.35

*Suggested Minimum Bore Diameter to accommodate chip evacuation and retract clearance in static (not live) applications.

Continued on next page

See pg 14-28 for quick change holder options

See pg 46 for miniature sizes

For better chip control and freer cutting action, see Helical Back Rake and Top Rake Chipbreaker tools on pgs 56-59

Quick Change – Boring Tools

Quick Change – Boring Tools

QBB

Right Hand (cont.)

Continued from previous page

Quick Change – Boring Tools

Head Width	Min. Bore Diameter*	Max. Bore Depth	Radius	Proj.	Length From Holder	Centerline Offset	Shank Diameter	Overall Length	Uncoated		AITIN Coated	
									Tool #	Price	Tool #	Price
H	L2	R	P	L4	F	D2 (h6)	L1					
	$^{+.030"}_{-.000"}$	$^{+.001"}_{-.001"}$										
.2300	.2500	.400	.005	.058	.853	.0738	.3125	2.0	QBB5-230400	48.35	QBB5-230400X	55.20
.2300	.2500	.500	.005	.058	.853	.0738	.3125	2.0	QBB-230500	48.35	QBB-230500X	54.95
.2300	.2500	.600	.005	.058	.853	.0738	.3125	2.0	QBB5-230600	48.35	QBB5-230600X	55.20
.2300	.2500	.700	.005	.058	.853	.0738	.3125	2.0	QBB5-230700	48.35	QBB5-230700X	55.20
.2300	.2500	.750	.005	.058	.853	.0738	.3125	2.0	QBB-230750	48.35	QBB-230750X	54.95
.2300	.2500	.800	.005	.058	1.353	.0738	.3125	2.5	QBB5-230800	49.65	QBB5-230800X	56.90
.2300	.2500	.900	.005	.058	1.353	.0738	.3125	2.5	QBB5-230900	49.65	QBB5-230900X	56.90
.2300	.2500	1.000	.005	.058	1.353	.0738	.3125	2.5	QBB-2301000	48.35	QBB-2301000X	55.60
.2300	.2500	1.100	.005	.058	1.353	.0738	.3125	2.5	QBB5-2301100	49.65	QBB5-2301100X	56.90
.2300	.2500	1.150	.005	.058	1.353	.0738	.3125	2.5	QBB5-2301150	49.65	QBB5-2301150X	56.90
.2300	.2500	1.200	.005	.058	1.353	.0738	.3125	2.5	QBB5-2301200	49.65	QBB5-2301200X	56.90
.2300	.2500	1.250	.005	.058	1.353	.0738	.3125	2.5	QBB-2301250	48.35	QBB-2301250X	55.60
.2300	.2500	1.400	.005	.058	1.853	.0738	.3125	3.0	QBB5-2301400	55.60	QBB5-2301400X	62.85
.2300	.2500	1.500	.005	.058	1.853	.0738	.3125	3.0	QBB-2301500	55.60	QBB-2301500X	62.85
.2300	.2500	1.600	.005	.058	1.853	.0738	.3125	3.0	QBB-2301600	55.60	QBB-2301600X	62.85
.2600	.2800	.400	.005	.065	.853	.1038	.3125	2.0	QBB5-260400	48.35	QBB5-260400X	55.20
.2600	.2800	.500	.005	.065	.853	.1038	.3125	2.0	QBB5-260500	48.35	QBB5-260500X	55.20
.2600	.2800	.600	.005	.065	.853	.1038	.3125	2.0	QBB5-260600	48.35	QBB5-260600X	55.20
.2600	.2800	.700	.005	.065	.853	.1038	.3125	2.0	QBB5-260700	48.35	QBB5-260700X	55.20
.2600	.2800	.750	.005	.065	.853	.1038	.3125	2.0	QBB5-260750	48.35	QBB5-260750X	55.20
.2600	.2800	.800	.005	.065	1.353	.1038	.3125	2.5	QBB5-260800	49.65	QBB5-260800X	56.90
.2600	.2800	.900	.005	.065	1.353	.1038	.3125	2.5	QBB5-260900	49.65	QBB5-260900X	56.90
.2600	.2800	1.000	.005	.065	1.353	.1038	.3125	2.5	QBB5-2601000	49.65	QBB5-2601000X	56.90
.2600	.2800	1.250	.005	.065	1.353	.1038	.3125	2.5	QBB5-2601250	49.65	QBB5-2601250X	56.90
.2900	.3100	.500	.005	.073	.853	.1338	.3125	2.0	QBB-290500	48.35	QBB-290500X	54.95
.2900	.3100	.600	.005	.073	.853	.1338	.3125	2.0	QBB5-290600	48.35	QBB5-290600X	55.20
.2900	.3100	.750	.005	.073	.853	.1338	.3125	2.0	QBB-290750	48.35	QBB-290750X	54.95
.2900	.3100	.900	.005	.073	1.353	.1338	.3125	2.5	QBB5-290900	49.65	QBB5-290900X	56.90
.2900	.3100	1.000	.005	.073	1.353	.1338	.3125	2.5	QBB-2901000	48.35	QBB-2901000X	55.60
.2900	.3100	1.100	.005	.073	1.353	.1338	.3125	2.5	QBB5-2901100	49.65	QBB5-2901100X	56.90
.2900	.3100	1.250	.005	.073	1.353	.1338	.3125	2.5	QBB-2901250	48.35	QBB-2901250X	55.60
.2900	.3100	1.350	.005	.073	1.853	.1338	.3125	3.0	QBB5-2901350	55.60	QBB5-2901350X	62.85
.2900	.3100	1.500	.005	.073	1.853	.1338	.3125	3.0	QBB-2901500	55.60	QBB-2901500X	62.85
.2900	.3100	1.600	.005	.073	1.853	.1338	.3125	3.0	QBB5-2901600	55.60	QBB5-2901600X	62.85
.2900	.3100	1.750	.005	.073	1.853	.1338	.3125	3.0	QBB-2901750	55.60	QBB-2901750X	62.85
.3200	.3400	.500	.005	.080	.853	.1325	.3750	2.0	QBB-320500	65.95	QBB-320500X	73.20
.3200	.3400	.600	.005	.080	.853	.1325	.3750	2.0	QBB5-320600	65.95	QBB5-320600X	74.05
.3200	.3400	.750	.005	.080	.853	.1325	.3750	2.0	QBB-320750	65.95	QBB-320750X	73.20
.3200	.3400	.900	.005	.080	1.353	.1325	.3750	2.5	QBB5-320900	67.60	QBB5-320900X	76.20
.3200	.3400	1.000	.005	.080	1.353	.1325	.3750	2.5	QBB-3201000	65.95	QBB-3201000X	74.55
.3200	.3400	1.100	.005	.080	1.353	.1325	.3750	2.5	QBB5-3201100	67.60	QBB5-3201100X	76.20

*Suggested Minimum Bore Diameter to accommodate chip evacuation and retract clearance in static (not live) applications.

Continued on next page

See pg 14-28 for quick change holder options

See pg 46 for miniature sizes

For better chip control and freer cutting action, see Helical Back Rake and Top Rake Chipbreaker tools on pgs 56-59

QBB

Quick Change – Boring Tools
Right Hand (cont.)

Continued from previous page

Head Width	Min. Bore Diameter*	Max. Bore Depth	Radius	Proj.	Length From Holder	Centerline Offset	Shank Diameter	Overall Length	Uncoated		AITIN Coated		
									Tool #	Price	Tool #	Price	
H	L ₂	$\begin{matrix} +.030'' \\ -.000'' \end{matrix}$	R	$\begin{matrix} +.001'' \\ -.001'' \end{matrix}$	P	L ₄	F	D ₂ (h6)	L ₁				
.3200	.3400	1.250	.005	.080	1.353	.1325	.3750	2.5	QBB-3201250	65.95	QBB-3201250X	74.55	
.3200	.3400	1.500	.005	.080	1.853	.1325	.3750	3.0	QBB-3201500	73.25	QBB-3201500X	81.85	
.3200	.3400	1.600	.005	.080	1.853	.1325	.3750	3.0	QBB5-3201600	73.25	QBB5-3201600X	81.85	
.3200	.3400	1.800	.005	.080	1.853	.1325	.3750	3.0	QBB-3201800	73.25	QBB-3201800X	81.85	
.3200	.3400	2.000	.005	.080	2.353	.1325	.3750	3.5	QBB-3202000	79.80	QBB-3202000X	89.05	
.3200	.3400	2.500	.005	.080	2.853	.1325	.3750	4.0	QBB-3202500	84.30	QBB-3202500X	93.55	
.3600	.3800	.500	.005	.090	.853	.1725	.3750	2.0	QBB5-3605000	65.95	QBB5-3605000X	74.05	
.3600	.3800	.750	.005	.090	.853	.1725	.3750	2.0	QBB-3607500	65.95	QBB-3607500X	73.20	
.3600	.3800	.900	.005	.090	1.353	.1725	.3750	2.5	QBB5-3609000	65.95	QBB5-3609000X	74.55	
.3600	.3800	1.000	.005	.090	1.353	.1725	.3750	2.5	QBB-3601000	65.95	QBB-3601000X	74.55	
.3600	.3800	1.250	.005	.090	1.353	.1725	.3750	2.5	QBB-3601250	65.95	QBB-3601250X	74.55	
.3600	.3800	1.500	.005	.090	1.853	.1725	.3750	3.0	QBB-3601500	73.25	QBB-3601500X	81.85	
.3600	.3800	1.800	.005	.090	1.853	.1725	.3750	3.0	QBB-3601800	73.25	QBB-3601800X	81.85	
.3600	.3800	2.000	.005	.090	2.353	.1725	.3750	3.5	QBB-3602000	79.80	QBB-3602000X	89.05	
.3600	.3800	2.500	.005	.090	2.853	.1725	.3750	4.0	QBB-3602500	84.30	QBB-3602500X	93.55	
.4100	.4300	.750	.005	.104	1.040	.1600	.5000	2.5	QBB5-4107500	91.85	QBB5-4107500X	103.55	
.4100	.4300	1.000	.005	.104	1.040	.1600	.5000	2.5	QBB5-4101000	91.85	QBB5-4101000X	103.55	
.4100	.4300	1.250	.005	.104	1.540	.1600	.5000	3.0	QBB5-4101250	94.20	QBB5-4101250X	105.90	
.4100	.4300	1.500	.005	.104	1.540	.1600	.5000	3.0	QBB5-4101500	94.20	QBB5-4101500X	105.90	
.4600	.4800	1.000	.005	.115	1.040	.2100	.5000	2.5	QBB-4601000	91.85	QBB-4601000X	103.40	
.4600	.4800	1.250	.005	.115	1.540	.2100	.5000	3.0	QBB-4601250	91.85	QBB-4601250X	103.40	
.4600	.4800	1.500	.005	.115	1.540	.2100	.5000	3.0	QBB-4601500	91.85	QBB-4601500X	103.40	
.4600	.4800	2.000	.005	.115	2.040	.2100	.5000	3.5	QBB-4602000	100.80	QBB-4602000X	113.35	
.4600	.4800	2.500	.005	.115	2.540	.2100	.5000	4.0	QBB-4602500	106.65	QBB-4602500X	119.20	
.4600	.4800	3.000	.005	.115	3.040	.2100	.5000	4.5	QBB-4603000	111.75	QBB-4603000X	125.25	
.4900	.5100	1.000	.005	.123	1.040	.2400	.5000	2.5	QBB-4901000	91.85	QBB-4901000X	103.40	
.4900	.5100	1.250	.005	.123	1.540	.2400	.5000	3.0	QBB-4901250	91.85	QBB-4901250X	103.40	
.4900	.5100	1.500	.005	.123	1.540	.2400	.5000	3.0	QBB-4901500	91.85	QBB-4901500X	103.40	
.4900	.5100	2.000	.005	.123	2.040	.2400	.5000	3.5	QBB-4902000	100.80	QBB-4902000X	113.35	
.4900	.5100	2.500	.005	.123	2.540	.2400	.5000	4.0	QBB-4902500	106.65	QBB-4902500X	119.20	
.4900	.5100	3.000	.005	.123	3.040	.2400	.5000	4.5	QBB-4903000	111.75	QBB-4903000X	125.25	

*Suggested Minimum Bore Diameter to accommodate chip evacuation and retract clearance in static (not live) applications.

See pg 14-28 for quick change holder options

See pg 46 for miniature sizes

For better chip control and freer cutting action, see Helical Back Rake and Top Rake Chipbreaker tools on pgs 56-59

Quick Change – Boring Tools

Helical Back Rake – Corner Radius

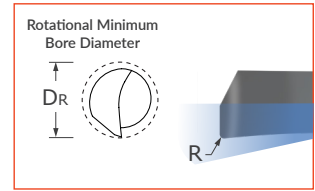
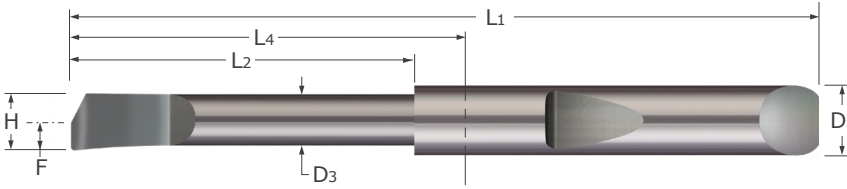

- Designed for boring applications in bores .030" and larger
- Polished face for improved edge retention and chip evacuation while reducing galling
- Helical grind provides ideal top rake for better chip control and freer cutting
- Well suited for machining plastics
- On center neck design allows for static and live/rotating applications
- Coolant fed enabled shank design
- Corner radius profile
- Proprietary Micro-Quik quick change system maximizes productivity through reliable accuracy and locational repeatability
- Solid carbide ■ CNC ground in the USA

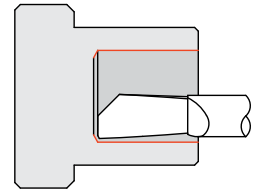

Quick Change – Boring Tools

Head Width	Rotational Min. Bore Diameter	Maximum Bore Depth	Radius	Length From Holder	Neck Diameter	Centerline Offset	Shank Diameter	Overall Length	Uncoated	
H	Dr	L2 ^{+ .050"} _{- .000"}	R ^{+ .003"} _{- .000"}	L4	D3 ^{+ .000"} _{- .002"}	F	D2 (h6)	L1	Tool #	Price
.0275	.030	.187	.004	.590	.025	.0150	.1875	1.5	QHBBC-030187-004	33.45
.0275	.030	.250	.004	.590	.025	.0150	.1875	1.5	QHBBC-030250-004	33.45
.0325	.035	.125	.004	.590	.030	.0175	.1875	1.5	QHBBC-035125-004	33.45
.0325	.035	.187	.004	.590	.030	.0175	.1875	1.5	QHBBC-035187-004	33.45
.0325	.035	.250	.004	.590	.030	.0175	.1875	1.5	QHBBC-035250-004	33.45
.0375	.040	.187	.004	.590	.035	.0200	.1875	1.5	QHBBC-040187-004	33.45
.0375	.040	.250	.004	.590	.035	.0200	.1875	1.5	QHBBC-040250-004	33.45
.0375	.040	.312	.004	.590	.035	.0200	.1875	1.5	QHBBC-040312-004	33.45
.0450	.050	.187	.004	.590	.040	.0250	.1875	1.5	QHBBC-050187-004	33.45
.0450	.050	.312	.004	.590	.040	.0250	.1875	1.5	QHBBC-050312-004	33.45
.0450	.050	.375	.004	.590	.040	.0250	.1875	1.5	QHBBC-050375-004	33.45
.0550	.060	.250	.004	.590	.050	.0300	.1875	1.5	QHBBC-060250-004	33.45
.0550	.060	.375	.004	.590	.050	.0300	.1875	1.5	QHBBC-060375-004	33.45
.0550	.060	.500	.004	.590	.050	.0300	.1875	1.5	QHBBC-060500-004	33.45
.0650	.070	.312	.004	.590	.060	.0350	.1875	1.5	QHBBC-070312-004	33.45
.0650	.070	.437	.004	.590	.060	.0350	.1875	1.5	QHBBC-070437-004	33.45
.0650	.070	.562	.004	1.090	.060	.0350	.1875	2.0	QHBBC-070562-004	33.45
.0750	.080	.375	.004	.590	.070	.0400	.1875	1.5	QHBBC-080375-004	33.45
.0750	.080	.500	.004	.590	.070	.0400	.1875	1.5	QHBBC-080500-004	33.45
.0750	.080	.625	.004	1.090	.070	.0400	.1875	2.0	QHBBC-080625-004	33.45
.0850	.090	.375	.004	.590	.080	.0450	.1875	1.5	QHBBC-090375-004	33.45
.0850	.090	.500	.004	.590	.080	.0450	.1875	1.5	QHBBC-090500-004	33.45
.0850	.090	.687	.004	1.090	.080	.0450	.1875	2.0	QHBBC-090687-004	33.45
.0950	.100	.437	.004	.590	.090	.0500	.1875	1.5	QHBBC-100437-004	33.45
.0950	.100	.562	.004	1.090	.090	.0500	.1875	2.0	QHBBC-100562-004	33.45
.0950	.100	.750	.004	1.090	.090	.0500	.1875	2.0	QHBBC-100750-004	33.45
.1100	.120	.500	.004	.590	.100	.0600	.1875	1.5	QHBBC-120500-004	33.45
.1100	.120	.625	.004	1.090	.100	.0600	.1875	2.0	QHBBC-120625-004	33.45
.1100	.120	1.000	.004	1.090	.100	.0600	.1875	2.0	QHBBC-1201000-004	33.45

Continued on next page

See pg 14-28 for quick change holder options

QHBBC

Quick Change – Boring Tools
Helical Back Rake – Corner Radius (cont.)

Continued from previous page

Head Width	Rotational Min. Bore Diameter	Maximum Bore Depth	Radius	Length From Holder	Neck Diameter	Centerline Offset	Shank Diameter	Overall Length	Uncoated	
H	D _r	L ₂ ^{+ .050"} _{- .000"}	R ^{+ .003"} _{- .000"}	L ₄	D ₃ ^{+ .000"} _{- .002"}	F	D ₂ (h6)	L ₁	Tool #	Price
.1225	.135	.562	.004	1.090	.110	.0675	.1875	2.0	QHBBC-135562-004	33.45
.1225	.135	.750	.004	1.090	.110	.0675	.1875	2.0	QHBBC-135750-004	33.45
.1225	.135	1.000	.004	1.090	.110	.0675	.1875	2.0	QHBBC-1351000-004	33.45
.1400	.150	.625	.004	1.090	.130	.0750	.1875	2.0	QHBBC-1500625-004	33.45
.1400	.150	1.000	.004	1.090	.130	.0750	.1875	2.0	QHBBC-1501000-004	33.45
.1400	.150	1.250	.004	1.590	.130	.0750	.1875	2.5	QHBBC-1501250-004	33.45
.1700	.180	1.000	.004	1.090	.160	.0900	.1875	2.0	QHBBC-1801000-004	33.45
.1700	.180	1.250	.004	1.590	.160	.0900	.1875	2.5	QHBBC-1801250-004	33.45
.1700	.180	1.500	.004	1.590	.160	.0900	.1875	2.5	QHBBC-1801500-004	33.45
.1975	.210	1.000	.004	1.353	.185	.1050	.2500	2.5	QHBBC-2101000-004	37.90
.1975	.210	1.250	.004	1.353	.185	.1050	.2500	2.5	QHBBC-2101250-004	37.90
.1975	.210	1.500	.004	1.853	.185	.1050	.2500	3.0	QHBBC-2101500-004	37.90
.2275	.240	1.000	.004	1.353	.215	.1200	.2500	2.5	QHBBC-2401000-004	37.90
.2275	.240	1.500	.004	1.853	.215	.1200	.2500	3.0	QHBBC-2401500-004	37.90
.2275	.240	1.750	.004	1.853	.215	.1200	.2500	3.0	QHBBC-2401750-004	37.90
.2750	.300	1.000	.004	1.353	.250	.1500	.3125	2.5	QHBBC-3001000-004	49.90
.2750	.300	1.500	.004	1.853	.250	.1500	.3125	3.0	QHBBC-3001500-004	49.90
.2750	.300	1.750	.004	1.853	.250	.1500	.3125	3.0	QHBBC-3001750-004	49.90
.3400	.360	1.000	.004	1.353	.320	.1800	.3750	2.5	QHBBC-3601000-004	67.95
.3400	.360	1.500	.004	1.853	.320	.1800	.3750	3.0	QHBBC-3601500-004	67.95
.3400	.360	2.000	.004	2.353	.320	.1800	.3750	3.5	QHBBC-3602000-004	84.85
.3400	.360	2.500	.004	2.853	.320	.1800	.3750	4.0	QHBBC-3602500-004	84.85

Quick Change – Boring Tools

Quick Change – Boring Tools

QBT

Top Rake Chipbreaker

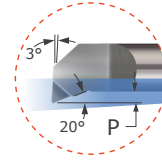
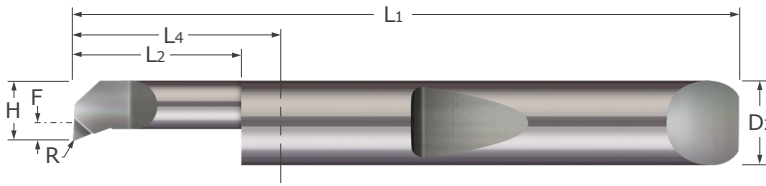

- Optimized for finishing operations
- Top rake geometry provides freer cutting
- Polished face for reducing galling
- Coolant fed enabled shank design
- Corner radius profile
- Proprietary Micro-Quik quick change system maximizes productivity through reliable accuracy and locational repeatability
- AlTiN coated option provides added lubricity and increased wear resistance in difficult to machine materials
- Solid carbide ■ CNC ground in the USA

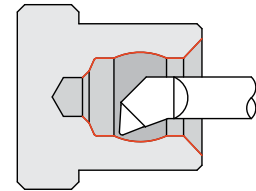

Quick Change – Boring Tools

Head Width	Min. Bore Diameter*	Max. Bore Depth	Radius	Proj.	Length From Holder	Centerline Offset	Shank Dia.	Overall Length	Uncoated		AlTiN Coated	
H		L2 ^{+0.030"} / _{-.000"}	R ^{+0.0005"} / _{-.0005"}	P	L4	F	D2 (h6)	L1	Tool #	Price	Tool #	Price
.0500	.0550	.200	.002	.005	.590	-.0438	.1875	1.5	QBT-050200	33.60	QBT-050200X	37.05
.0500	.0550	.400	.002	.005	.590	-.0438	.1875	1.5	QBT-050400	33.60	QBT-050400X	37.05
.0500	.0550	.500	.002	.005	.590	-.0438	.1875	1.5	QBT-050500	33.60	QBT-050500X	37.05
.0600	.0700	.200	.002	.010	.590	-.0338	.1875	1.5	QBT-060200	33.60	QBT-060200X	37.05
.0600	.0700	.400	.002	.010	.590	-.0338	.1875	1.5	QBT-060400	33.60	QBT-060400X	37.05
.0600	.0700	.500	.002	.010	.590	-.0338	.1875	1.5	QBT-060500	33.60	QBT-060500X	37.05
.0700	.0800	.200	.004	.015	.590	-.0238	.1875	1.5	QBT-070200	33.60	QBT-070200X	37.05
.0700	.0800	.400	.004	.015	.590	-.0238	.1875	1.5	QBT-070400	33.60	QBT-070400X	37.05
.0700	.0800	.600	.004	.015	1.090	-.0238	.1875	2.0	QBT-070600	33.60	QBT-070600X	37.05
.1100	.1220	.250	.004	.020	.590	.0163	.1875	1.5	QBT-110250	33.60	QBT-110250X	37.05
.1100	.1220	.500	.004	.020	.590	.0163	.1875	1.5	QBT-110500	33.60	QBT-110500X	37.05
.1100	.1220	.750	.004	.020	1.090	.0163	.1875	2.0	QBT-110750	33.60	QBT-110750X	37.05
.1200	.1320	.250	.004	.020	.590	.0263	.1875	1.5	QBT-120250	33.60	QBT-120250X	37.05
.1200	.1320	.375	.004	.020	.590	.0263	.1875	1.5	QBT4-120375	33.60	QBT4-120375X	37.05
.1200	.1320	.500	.004	.020	.590	.0263	.1875	1.5	QBT-120500	33.60	QBT-120500X	37.05
.1200	.1320	.750	.004	.020	1.090	.0263	.1875	2.0	QBT-120750	33.60	QBT-120750X	37.05
.1200	.1320	1.000	.004	.020	1.090	.0263	.1875	2.0	QBT-1201000	33.60	QBT-1201000X	37.05
.1400	.1520	.250	.004	.025	.590	.0463	.1875	1.5	QBT4-140250	33.60	QBT4-140250X	37.05
.1400	.1520	.375	.004	.025	.590	.0463	.1875	1.5	QBT4-140375	33.60	QBT4-140375X	37.05
.1400	.1520	.500	.004	.025	.590	.0463	.1875	1.5	QBT4-140500	33.60	QBT4-140500X	37.05
.1600	.1760	.375	.006	.025	.590	.0663	.1875	1.5	QBT6-160375	33.60	QBT6-160375X	37.05
.1600	.1760	.500	.006	.025	.590	.0663	.1875	1.5	QBT-160500	33.60	QBT-160500X	37.05
.1600	.1760	.750	.006	.025	1.090	.0663	.1875	2.0	QBT-160750	33.60	QBT-160750X	37.05
.1600	.1760	1.000	.006	.025	1.090	.0663	.1875	2.0	QBT-1601000	33.60	QBT-1601000X	37.05
.1600	.1760	1.250	.006	.025	1.590	.0663	.1875	2.5	QBT-1601250	33.60	QBT-1601250X	38.20

*Suggested Minimum Bore Diameter to accommodate chip evacuation and retract clearance in static (not live) applications.

Continued on next page

See pg 14-28 for quick change holder options

QBT

Quick Change – Boring Tools

Top Rake Chipbreaker (cont.)

Continued from previous page

Head Width	Min. Bore Diameter*	Max. Bore Depth	Radius	Proj.	Length From Holder	Centerline Offset	Shank Dia.	Overall Length	Uncoated		AITIN Coated	
									Tool #	Price	Tool #	Price
H		L ₂ ^{+0.030"} / _{-.000"}	R ^{+0.005"} / _{-.0005"}	P	L ₄	F	D ₂ (h6)	L ₁				
.1800	.1960	.375	.006	.030	.853	.0550	.2500	2.0	QBT6-180375	42.00	QBT6-180375X	47.65
.1800	.1960	.500	.006	.030	.853	.0550	.2500	2.0	QBT-180500	42.00	QBT-180500X	47.65
.1800	.1960	.750	.006	.030	.853	.0550	.2500	2.0	QBT-180750	42.00	QBT-180750X	47.65
.1800	.1960	1.000	.006	.030	1.353	.0550	.2500	2.5	QBT-1801000	42.00	QBT-1801000X	48.00
.1800	.1960	1.250	.006	.030	1.353	.0550	.2500	2.5	QBT-1801250	42.00	QBT-1801250X	48.00
.1800	.1960	1.500	.006	.030	1.853	.0550	.2500	3.0	QBT-1801500	48.30	QBT-1801500X	54.35
.2000	.2160	.375	.006	.030	.853	.0750	.2500	2.0	QBT6-200375	42.00	QBT6-200375X	47.65
.2000	.2160	.600	.006	.030	.853	.0750	.2500	2.0	QBT-200600	42.00	QBT-200600X	47.65
.2000	.2160	.750	.006	.030	.853	.0750	.2500	2.0	QBT6-200750	42.00	QBT6-200750X	47.65
.2000	.2160	1.000	.006	.030	1.353	.0750	.2500	2.5	QBT-2001000	42.00	QBT-2001000X	48.00
.2000	.2160	1.250	.006	.030	1.353	.0750	.2500	2.5	QBT-2001250	42.00	QBT-2001250X	48.00
.2000	.2160	1.500	.006	.030	1.853	.0750	.2500	3.0	QBT-2001500	48.30	QBT-2001500X	54.35
.2300	.2500	.500	.004	.040	.853	.0738	.3125	2.0	QBT4-230500	52.40	QBT4-230500X	59.15
.2300	.2500	.500	.006	.040	.853	.0738	.3125	2.0	QBT6-230500	52.40	QBT6-230500X	59.15
.2300	.2500	.750	.004	.040	.853	.0738	.3125	2.0	QBT4-230750	52.40	QBT4-230750X	59.15
.2300	.2500	.750	.006	.040	.853	.0738	.3125	2.0	QBT-230750	52.40	QBT-230750X	59.15
.2300	.2500	1.100	.006	.040	1.353	.0738	.3125	2.5	QBT-2301100	52.40	QBT-2301100X	59.65
.2300	.2500	1.300	.006	.040	1.353	.0738	.3125	2.5	QBT-2301300	52.40	QBT-2301300X	59.65
.2300	.2500	1.600	.006	.040	1.853	.0738	.3125	3.0	QBT-2301600	61.10	QBT-2301600X	68.35
.2600	.2800	.500	.004	.045	.853	.1038	.3125	2.0	QBT4-260500	52.40	QBT4-260500X	59.15
.2600	.2800	.500	.006	.045	.853	.1038	.3125	2.0	QBT6-260500	52.40	QBT6-260500X	59.15
.2600	.2800	.750	.004	.045	.853	.1038	.3125	2.0	QBT4-260750	52.40	QBT4-260750X	59.15
.2600	.2800	.750	.006	.045	.853	.1038	.3125	2.0	QBT6-260750	52.40	QBT6-260750X	59.15
.3000	.3200	.750	.006	.050	.853	.1125	.3750	2.0	QBT6-300750	52.40	QBT6-300750X	59.15
.3000	.3200	1.000	.006	.050	1.353	.1125	.3750	2.5	QBT-3001000	63.00	QBT-3001000X	71.60
.3000	.3200	1.250	.006	.050	1.353	.1125	.3750	2.5	QBT6-3001250	63.00	QBT6-3001250X	71.60
.3000	.3200	1.600	.006	.050	1.853	.1125	.3750	3.0	QBT-3001600	70.45	QBT-3001600X	79.05
.3000	.3200	2.100	.006	.050	2.853	.1125	.3750	3.5	QBT-3002100	76.75	QBT-3002100X	86.00
.3600	.3800	1.000	.006	.050	1.353	.1725	.3750	2.5	QBT-3601000	63.00	QBT-3601000X	71.60
.3600	.3800	1.600	.006	.050	1.853	.1725	.3750	3.0	QBT-3601600	70.45	QBT-3601600X	79.05
.3600	.3800	2.100	.006	.050	2.353	.1725	.3750	3.5	QBT-3602100	76.75	QBT-3602100X	86.00
.4600	.4800	1.000	.006	.075	1.040	.2100	.5000	2.5	QBT-4601000	95.75	QBT-4601000X	107.45
.4600	.4800	1.600	.006	.075	2.040	.2100	.5000	3.5	QBT-4601600	95.75	QBT-4601600X	107.50
.4600	.4800	2.100	.006	.075	2.540	.2100	.5000	4.0	QBT-4602100	101.10	QBT-4602100X	113.65
.4900	.5100	1.000	.006	.075	1.040	.2400	.5000	2.5	QBT-4901000	95.75	QBT-4901000X	107.45
.4900	.5100	1.600	.006	.075	2.040	.2400	.5000	3.5	QBT-4901600	95.75	QBT-4901600X	107.50
.4900	.5100	2.100	.006	.075	2.540	.2400	.5000	4.0	QBT-4902100	101.10	QBT-4902100X	113.65

*Suggested Minimum Bore Diameter to accommodate chip evacuation and retract clearance in static (not live) applications.

Quick Change – Boring Tools

Boring Head Tools

Quick Change – Boring Tools

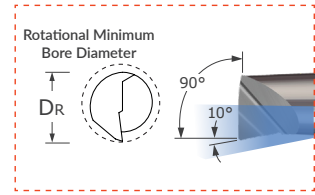
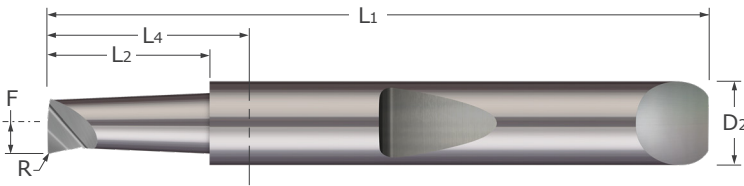

- Designed for boring applications requiring maximum rigidity
- Tapered neck and top rake geometry for increased performance
- Polished face for reducing galling
- Coolant fed enabled shank design
- Corner radius profile
- Proprietary Micro-Quik quick change system maximizes productivity through reliable accuracy and locational repeatability
- AlTiN coated option provides added lubricity and increased wear resistance in difficult to machine materials
- Solid carbide ■ CNC ground in the USA

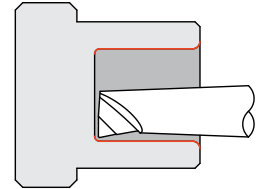

Rotational Minimum Bore Diameter	Maximum Bore Depth	Radius	Length From Holder	Centerline Offset	Shank Diameter	Overall Length	Uncoated		AlTiN Coated	
							Tool #	Price	Tool #	Price
DR	L2 ^{+0.030"} / _{-.000"}	R ^{+0.001"} / _{-.001"}	L4	F	D2 (h6)	L1				
.1180	.500	.003	.853	.0550	.2500	2.0	QBM-118500	36.05	QBM-118500X	41.70
.1180	.750	.003	.853	.0550	.2500	2.0	QBM-118750	36.05	QBM-118750X	41.70
.1500	.500	.003	.853	.0710	.2500	2.0	QBM-150500	36.05	QBM-150500X	41.70
.1500	.750	.003	.853	.0710	.2500	2.0	QBM-150750	36.05	QBM-150750X	41.70
.2000	.500	.008	.853	.0950	.2500	2.0	QBM-200500	36.05	QBM-200500X	41.70
.2000	.750	.008	.853	.0950	.2500	2.0	QBM-200750	36.05	QBM-200750X	41.70
.2000	1.250	.008	1.353	.0950	.2500	2.5	QBM-2001250	36.05	QBM-2001250X	41.80
.2300	.750	.008	.853	.1100	.2500	2.0	QBM-230750	36.05	QBM-230750X	41.70
.2300	1.250	.008	1.353	.1100	.2500	2.5	QBM-2301250	36.05	QBM-2301250X	41.80
.2300	1.500	.008	1.853	.1100	.2500	3.0	QBM-2301500	40.75	QBM-2301500X	46.75
.3000	1.000	.008	1.353	.1450	.3750	2.5	QBM-3001000	65.95	QBM-3001000X	74.55
.3000	1.500	.008	1.853	.1450	.3750	3.0	QBM-3001500	73.25	QBM-3001500X	81.85
.3000	1.750	.008	1.853	.1450	.3750	3.0	QBM-3001750	73.25	QBM-3001750X	81.85
.3600	1.000	.008	1.353	.1750	.3750	2.5	QBM-3601000	65.95	QBM-3601000X	74.55
.3600	1.500	.008	1.853	.1750	.3750	3.0	QBM-3601500	73.25	QBM-3601500X	81.85
.3600	2.000	.008	2.353	.1750	.3750	3.5	QBM-3602000	79.80	QBM-3602000X	89.05
.4600	1.000	.008	1.040	.2250	.5000	2.5	QBM-4601000	91.85	QBM-4601000X	103.40
.4600	1.500	.008	1.540	.2250	.5000	3.0	QBM-4601500	91.85		
.4600	2.000	.008	2.040	.2250	.5000	3.5	QBM-4602000	100.80	QBM-4602000X	113.35
.4600	2.500	.008	2.540	.2250	.5000	4.0	QBM-4602500	106.65	QBM-4602500X	119.20
.4600	3.000	.008	3.040	.2250	.5000	4.5	QBM-4603000	111.75	QBM-4603000X	125.25

See pg 14-28 for quick change holder options

QRB

Quick Change – Boring Tools
Reverse Boring

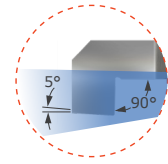
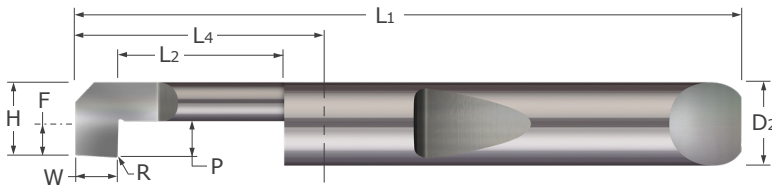

- Designed to bore from the inside, toward the face of the part
- Polished split face for improved edge retention and chip evacuation while reducing galling
- Split face geometry provides optimal edge strength
- Coolant fed enabled shank design
- Inside corner radius profile
- Proprietary Micro-Quik quick change system maximizes productivity through reliable accuracy and locational repeatability
- AlTiN coated option provides added lubricity and increased wear resistance in difficult to machine materials
- Solid carbide ■ CNC ground in the USA

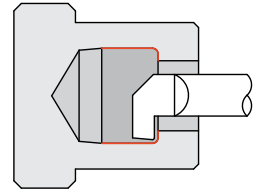

Quick Change – Boring Tools

Head Width	Min. Bore Dia.*	Max. Bore Depth	Width	Radius	Proj.	Length From Holder	Centerline Offset	Shank Dia.	Overall Length	Uncoated		AlTiN Coated	
										Tool #	Price	Tool #	Price
H		L2 ^{+0.015"} / _{-.000"}	W ^{+0.002"} / _{-.000"}	R ^{+0.001"} / _{-.001"}	P	L4	F	D2 (h6)	L1				
.1560	.1720	.500	.075	.005	.060	.590	.0623	.1875	1.5	QRB-156500	33.40	QRB-156500X	36.80
.1560	.1720	.750	.075	.005	.060	1.090	.0623	.1875	2.0	QRB-156750	33.40	QRB-156750X	36.80
.1560	.1720	1.000	.075	.005	.060	1.090	.0623	.1875	2.0	QRB-1561000	33.40	QRB-1561000X	36.80
.1800	.1960	.500	.100	.005	.080	.853	.0550	.2500	2.0	QRB-180500	36.05	QRB-180500X	41.70
.1800	.1960	.750	.100	.005	.080	1.353	.0550	.2500	2.5	QRB-180750	36.05	QRB-180750X	41.80
.1800	.1960	1.000	.100	.005	.080	1.353	.0550	.2500	2.5	QRB-1801000	36.05	QRB-1801000X	41.80
.2000	.2160	.500	.113	.008	.090	.853	.0750	.2500	2.0	QRB-200500	36.05	QRB-200500X	41.70
.2000	.2160	.750	.113	.008	.090	1.353	.0750	.2500	2.5	QRB-200750	36.05	QRB-200750X	41.80
.2000	.2160	1.000	.113	.008	.090	1.353	.0750	.2500	2.5	QRB-2001000	36.05	QRB-2001000X	41.80
.2000	.2160	1.250	.113	.008	.090	1.853	.0750	.2500	3.0	QRB-2001250	42.30		
.2300	.2500	.500	.138	.008	.110	.853	.0738	.3125	2.0	QRB-230500	48.35	QRB-230500X	54.95
.2300	.2500	.750	.138	.008	.110	1.353	.0738	.3125	2.5	QRB-230750	48.35	QRB-230750X	55.60
.2300	.2500	1.000	.138	.008	.110	1.353	.0738	.3125	2.5	QRB-2301000	48.35	QRB-2301000X	55.60
.2300	.2500	1.250	.138	.008	.110	1.853	.0738	.3125	3.0	QRB-2301250	55.60	QRB-2301250X	62.85
.3000	.3200	.500	.138	.008	.110	.853	.1438	.3125	2.0	QRB-300500	48.35	QRB-300500X	54.95
.3000	.3200	.750	.138	.008	.110	1.353	.1438	.3125	2.5	QRB-300750	48.35	QRB-300750X	54.95
.3000	.3200	1.000	.138	.008	.110	1.353	.1438	.3125	2.5	QRB-3001000	48.35	QRB-3001000X	55.60
.3000	.3200	1.250	.138	.008	.110	1.853	.1438	.3125	3.0	QRB-3001250	55.60	QRB-3001250X	62.85
.3600	.3800	.750	.163	.008	.130	1.353	.1725	.3750	2.5	QRB-360750	65.95	QRB-360750X	74.55
.3600	.3800	1.000	.163	.008	.130	1.353	.1725	.3750	2.5	QRB-3601000	65.95	QRB-3601000X	74.55
.3600	.3800	1.250	.163	.008	.130	1.853	.1725	.3750	3.0	QRB-3601250	73.25	QRB-3601250X	81.85
.3600	.3800	1.500	.163	.008	.130	1.853	.1725	.3750	3.0	QRB-3601500	73.25	QRB-3601500X	81.85
.4600	.4800	1.000	.200	.008	.160	1.540	.2100	.5000	3.0	QRB-4601000	91.85	QRB-4601000X	103.40
.4600	.4800	1.250	.200	.008	.160	1.540	.2100	.5000	3.0	QRB-4601250	91.85	QRB-4601250X	103.55
.4600	.4800	1.500	.200	.008	.160	2.040	.2100	.5000	3.5	QRB-4601500	100.80	QRB-4601500X	113.35
.4600	.4800	1.800	.200	.008	.160	2.040	.2100	.5000	3.5	QRB-4601800	100.80	QRB-4601800X	113.35
.4900	.5100	1.000	.200	.008	.160	1.540	.2400	.5000	3.0	QRB-4901000	91.85	QRB-4901000X	103.40
.4900	.5100	1.250	.200	.008	.160	1.540	.2400	.5000	3.0	QRB-4901250	91.85	QRB-4901250X	103.55
.4900	.5100	1.500	.200	.008	.160	2.040	.2400	.5000	3.5	QRB-4901500	100.80	QRB-4901500X	113.35
.4900	.5100	1.800	.200	.008	.160	2.040	.2400	.5000	3.5	QRB-4901800	100.80	QRB-4901800X	113.35

*Suggested Minimum Bore Diameter to accommodate chip evacuation and retract clearance in static (not live) applications.

See pg 14-28 for quick change holder options

Quick Change – Profiling Tools

QPR

Radial Profiling

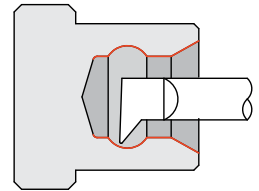
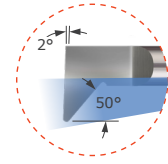
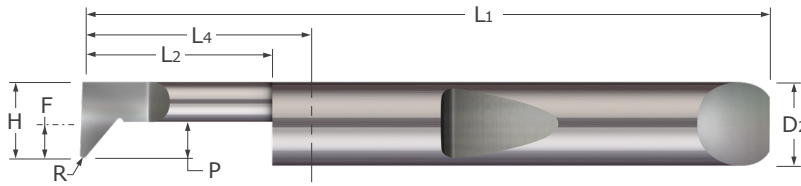

Quick Change – Profiling Tools

- Designed for radial profiling
- Excellent choice for fine finishing
- Can be used in thread relief applications
- Split face geometry provides optimal edge strength
- Coolant fed enabled shank design
- Corner radius profile
- Proprietary Micro-Quik quick change system maximizes productivity through reliable accuracy and locational repeatability
- AlTiN coated option provides added lubricity and increased wear resistance in difficult to machine materials
- Solid carbide ■ CNC ground in the USA

Head Width	Minimum Bore Dia.*	Maximum Bore Depth	Radius	Projection	Length From Holder	Centerline Offset	Shank Dia.	Overall Length	Uncoated		AlTiN Coated	
H		L2	R	P	L4	F	D2 (h6)	L1	Tool #	Price	Tool #	Price
.0700	.0800	.200	.0050	.025	.590	-.0238	.1875	1.5	QPR-070200	33.60	QPR-070200X	37.05
.0700	.0800	.300	.0050	.025	.590	-.0238	.1875	1.5	QPR-070300	33.60	QPR-070300X	37.05
.0700	.0800	.500	.0050	.025	.590	-.0238	.1875	1.5	QPR-070500	33.60	QPR-070500X	37.05
.1000	.1100	.200	.0050	.035	.590	.0063	.1875	1.5	QPR5-100200	33.60	QPR5-100200X	37.05
.1000	.1100	.300	.0050	.035	.590	.0063	.1875	1.5	QPR5-100300	33.60	QPR5-100300X	37.05
.1100	.1240	.250	.0050	.040	.590	.0163	.1875	1.5	QPR-110250	33.60	QPR-110250X	37.05
.1100	.1240	.375	.0050	.040	.590	.0163	.1875	1.5	QPR5-110375	33.60	QPR5-110375X	37.05
.1100	.1240	.500	.0050	.040	.590	.0163	.1875	1.5	QPR-110500	33.60	QPR-110500X	37.05
.1200	.1340	.250	.0080	.050	.590	.0263	.1875	1.5	QPR-120250	33.60	QPR-120250X	37.05
.1200	.1340	.375	.0050	.050	.590	.0263	.1875	1.5	QPR5-120375	33.60	QPR5-120375X	37.05
.1200	.1340	.375	.0080	.050	.590	.0263	.1875	1.5	QPR8-120375	33.60	QPR8-120375X	37.05
.1200	.1340	.500	.0080	.050	.590	.0263	.1875	1.5	QPR-120500	33.60	QPR-120500X	37.05
.1200	.1340	.750	.0050	.050	1.090	.0263	.1875	2.0	QPR5-120750	33.60	QPR5-120750X	37.05
.1200	.1340	.750	.0080	.050	1.090	.0263	.1875	2.0	QPR-120750	33.60	QPR-120750X	37.05
.1400	.1540	.375	.0050	.050	.590	.0463	.1875	1.5	QPR5-140375	33.60	QPR5-140375X	37.05
.1400	.1540	.375	.0080	.050	.590	.0463	.1875	1.5	QPR8-140375	33.60	QPR8-140375X	37.05
.1400	.1540	.500	.0050	.050	.590	.0463	.1875	1.5	QPR5-140500	33.60	QPR5-140500X	37.05
.1400	.1540	.500	.0080	.050	.590	.0463	.1875	1.5	QPR8-140500	33.60	QPR8-140500X	37.05
.1600	.1780	.375	.0080	.050	.590	.0663	.1875	1.5	QPR8-160375	33.60	QPR8-160375X	37.05
.1600	.1780	.500	.0080	.050	.590	.0663	.1875	1.5	QPR-160500	33.60	QPR-160500X	37.05
.1600	.1780	.750	.0080	.050	1.090	.0663	.1875	2.0	QPR-160750	33.60	QPR-160750X	37.05
.1600	.1780	1.000	.0080	.050	1.090	.0663	.1875	2.0	QPR-1601000	33.60	QPR-1601000X	37.05
.1800	.1980	.375	.0080	.080	.853	.0550	.2500	2.0	QPR8-180375	42.00	QPR8-180375X	47.65
.1800	.1980	.500	.0080	.080	.853	.0550	.2500	2.0	QPR-180500	42.00	QPR-180500X	47.65
.1800	.1980	.750	.0080	.080	.853	.0550	.2500	2.0	QPR-180750	42.00	QPR-180750X	47.65
.1800	.1980	1.000	.0080	.080	1.353	.0550	.2500	2.5	QPR-1801000	42.00	QPR-1801000X	48.00

*Suggested Minimum Bore Diameter to accommodate chip evacuation and retract clearance in static (not live) applications.

Continued on next page

See pg 14-28 for quick change holder options

QPR

Quick Change – Profiling Tools

Radial Profiling (cont.)

Continued from previous page

Head Width	Minimum Bore Dia.*	Maximum Bore Depth	Radius	Projection	Length From Holder	Centerline Offset	Shank Dia.	Overall Length	Uncoated		AlTiN Coated	
									Tool #	Price	Tool #	Price
H		L2 ^{+0.030"} / _{-.000"}	R ^{+0.0005"} / _{-.0005"}	P	L4	F	D2 (h6)	L1				
.2000	.2180	.500	.0050	.080	.853	.0750	.2500	2.0	QPR5-200500	42.00	QPR5-200500X	47.65
.2000	.2180	.500	.0080	.080	.853	.0750	.2500	2.0	QPR8-200500	42.00	QPR8-200500X	47.65
.2000	.2180	.750	.0050	.080	.853	.0750	.2500	2.0	QPR5-200750	42.00	QPR5-200750X	47.65
.2000	.2180	.750	.0080	.080	.853	.0750	.2500	2.0	QPR8-200750	42.00	QPR8-200750X	47.65
.2300	.2520	.500	.0080	.080	.853	.0738	.3125	2.0	QPR8-230500	52.40	QPR8-230500X	59.15
.2300	.2520	.750	.0080	.080	.853	.0738	.3125	2.0	QPR-230750	52.40	QPR-230750X	59.15
.2300	.2520	1.000	.0080	.080	1.353	.0738	.3125	2.5	QPR-2301000	52.40	QPR-2301000X	59.65
.2300	.2520	1.250	.0080	.080	1.353	.0738	.3125	2.5	QPR-2301250	52.40	QPR-2301250X	59.65
.2600	.2820	.750	.0080	.090	.853	.1038	.3125	2.0	QPR8-260750	52.40	QPR8-260750X	59.15
.2600	.2820	1.000	.0080	.090	1.353	.1038	.3125	2.5	QPR8-2601000	52.40	QPR8-2601000X	59.65
.3000	.3220	.750	.0080	.110	.853	.1438	.3125	2.0	QPR8-300750	52.40	QPR8-300750X	59.15
.3000	.3220	1.000	.0080	.110	1.353	.1438	.3125	2.5	QPR-3001000	52.40	QPR-3001000X	59.65
.3000	.3220	1.250	.0080	.110	1.353	.1438	.3125	2.5	QPR-3001250	52.40	QPR-3001250X	59.65
.3600	.3820	.750	.0080	.130	.853	.1725	.3750	2.0	QPR8-360750	68.35	QPR8-360750X	75.70
.3600	.3820	1.000	.0080	.130	1.353	.1725	.3750	2.5	QPR-3601000	68.35	QPR-3601000X	76.95
.3600	.3820	1.250	.0080	.130	1.353	.1725	.3750	2.5	QPR-3601250	68.35	QPR-3601250X	76.95
.4600	.4820	.750	.0080	.150	1.040	.2100	.5000	2.5	QPR8-460750	95.75	QPR8-460750X	107.45
.4600	.4820	1.000	.0080	.150	1.540	.2100	.5000	3.0	QPR-4601000	95.75	QPR-4601000X	107.45
.4600	.4820	1.500	.0080	.150	1.540	.2100	.5000	3.0	QPR-4601500	95.75	QPR-4601500X	107.45
.4600	.4820	1.800	.0080	.150	2.040	.2100	.5000	3.5	QPR-4601800	104.50	QPR-4601800X	117.05
.4900	.5120	1.000	.0080	.150	1.540	.2400	.5000	3.0	QPR-4901000	95.75	QPR-4901000X	107.45
.4900	.5120	1.500	.0080	.150	1.540	.2400	.5000	3.0	QPR-4901500	95.75	QPR-4901500X	107.45
.4900	.5120	1.800	.0080	.150	2.040	.2400	.5000	3.5	QPR-4901800	104.50	QPR-4901800X	117.05

*Suggested Minimum Bore Diameter to accommodate chip evacuation and retract clearance in static (not live) applications.

Quick Change – Profiling Tools

Quick Change – Profiling Tools

Angled Profiling

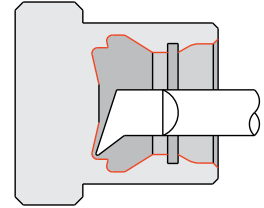
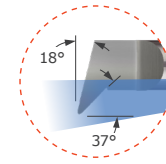
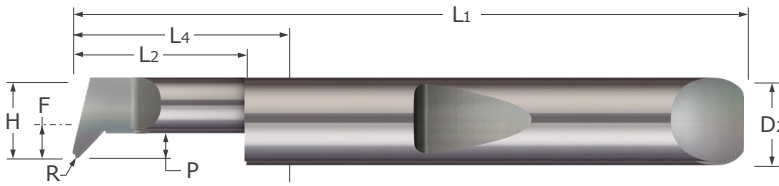

Quick Change – Profiling Tools

- Designed for both radial and axial profiling
- Unique design maximizes tool versatility and part feature creation
- Excellent choice for fine finishing
- Coolant fed enabled shank design
- Corner radius profile
- Proprietary Micro-Quik quick change system maximizes productivity through reliable accuracy and locational repeatability
- AlTiN coated option provides added lubricity and increased wear resistance in difficult to machine materials
- Solid carbide ■ CNC ground in the USA

Head Width	Minimum Bore Dia*	Maximum Bore Depth	Radius	Projection	Length From Holder	Centerline Offset	Shank Dia.	Overall Length	Uncoated		AlTiN Coated	
									Tool #	Price	Tool #	Price
H	L2	$L2 \begin{smallmatrix} +.030'' \\ -.000'' \end{smallmatrix}$	$R \begin{smallmatrix} +.0005'' \\ -.0005'' \end{smallmatrix}$	P	L4	F	D2 (h6)	L1				
.0500	.0550	.150	.0020	.015	.590	-.0438	.1875	1.5	QPA2-050150	33.60	QPA2-050150X	37.05
.0500	.0550	.200	.0020	.015	.590	-.0438	.1875	1.5	QPA2-050200	33.60	QPA2-050200X	37.05
.0600	.0700	.150	.0020	.020	.590	-.0338	.1875	1.5	QPA2-060150	33.60	QPA2-060150X	37.05
.0600	.0700	.200	.0020	.020	.590	-.0338	.1875	1.5	QPA2-060200	33.60	QPA2-060200X	37.05
.0700	.0800	.150	.0020	.020	.590	-.0238	.1875	1.5	QPA2-070150	33.60	QPA2-070150X	37.05
.0700	.0800	.200	.0020	.020	.590	-.0238	.1875	1.5	QPA2-070200	33.60	QPA2-070200X	37.05
.0800	.0900	.200	.0020	.025	.590	-.0138	.1875	1.5	QPA2-080200	33.60	QPA2-080200X	37.05
.0800	.0900	.300	.0020	.025	.590	-.0138	.1875	1.5	QPA2-080300	33.60	QPA2-080300X	37.05
.0900	.1000	.200	.0020	.030	.590	-.0038	.1875	1.5	QPA2-090200	33.60	QPA2-090200X	37.05
.0900	.1000	.300	.0020	.030	.590	-.0038	.1875	1.5	QPA2-090300	33.60	QPA2-090300X	37.05
.1000	.1100	.200	.0020	.030	.590	.0063	.1875	1.5	QPA2-100200	33.60	QPA2-100200X	37.05
.1000	.1100	.200	.0050	.030	.590	.0063	.1875	1.5	QPA5-100200	33.60	QPA5-100200X	37.05
.1000	.1100	.300	.0020	.030	.590	.0063	.1875	1.5	QPA2-100300	33.60	QPA2-100300X	37.05
.1000	.1100	.300	.0050	.030	.590	.0063	.1875	1.5	QPA5-100300	33.60	QPA5-100300X	37.05
.1100	.1240	.250	.0050	.035	.590	.0163	.1875	1.5	QPA5-110250	33.60	QPA5-110250X	37.05
.1100	.1240	.375	.0050	.035	.590	.0163	.1875	1.5	QPA5-110375	33.60	QPA5-110375X	37.05
.1200	.1340	.250	.0050	.035	.590	.0263	.1875	1.5	QPA5-120250	33.60	QPA5-120250X	37.05
.1200	.1340	.375	.0050	.035	.590	.0263	.1875	1.5	QPA5-120375	33.60	QPA5-120375X	37.05
.1400	.1540	.375	.0050	.040	.590	.0463	.1875	1.5	QPA5-140375	33.60	QPA5-140375X	37.05
.1400	.1540	.500	.0050	.040	.590	.0463	.1875	1.5	QPA5-140500	33.60	QPA5-140500X	37.05
.1600	.1780	.375	.0050	.050	.590	.0663	.1875	1.5	QPA5-160375	33.60	QPA5-160375X	37.05
.1600	.1780	.500	.0050	.050	.590	.0663	.1875	1.5	QPA5-160500	33.60	QPA5-160500X	37.05
.1800	.1980	.375	.0050	.055	.853	.0550	.2500	2.0	QPA5-180375	42.00	QPA5-180375X	47.65
.1800	.1980	.500	.0050	.055	.853	.0550	.2500	2.0	QPA5-180500	42.00	QPA5-180500X	47.65

*Suggested Minimum Bore Diameter to accommodate chip evacuation and retract clearance in static (not live) applications.

Continued on next page

See pg 14-28 for quick change holder options

QPA

Quick Change – Profiling Tools
Angled Profiling (cont.)

Continued from previous page

Head Width	Minimum Bore Dia*	Maximum Bore Depth	Radius	Projection	Length From Holder	Centerline Offset	Shank Dia.	Overall Length	Uncoated		AITIN Coated	
									Tool #	Price	Tool #	Price
H		L2 ^{+0.030"} / _{-.000"}	R ^{+0.0005"} / _{-.0005"}	P	L4	F	D2 (h6)	L1				
.2000	.2180	.500	.0050	.060	.853	.0750	.2500	2.0	QPA5-200500	42.00	QPA5-200500X	47.65
.2000	.2180	.500	.0080	.060	.853	.0750	.2500	2.0	QPA8-200500	42.00	QPA8-200500X	47.65
.2000	.2180	.750	.0050	.060	.853	.0750	.2500	2.0	QPA5-200750	42.00	QPA5-200750X	47.65
.2000	.2180	.750	.0080	.060	.853	.0750	.2500	2.0	QPA8-200750	42.00	QPA8-200750X	47.65
.2300	.2520	.500	.0080	.070	.853	.0738	.3125	2.0	QPA8-230500	52.40	QPA8-230500X	59.15
.2300	.2520	.750	.0080	.070	.853	.0738	.3125	2.0	QPA8-230750	52.40	QPA8-230750X	59.15
.2600	.2820	.750	.0080	.080	.853	.1038	.3125	2.0	QPA8-260750	52.40	QPA8-260750X	59.15
.2600	.2820	1.000	.0080	.080	1.353	.1038	.3125	2.5	QPA8-2601000	52.40	QPA8-2601000X	59.65
.3000	.3220	.750	.0080	.090	.853	.1438	.3125	2.0	QPA8-300750	52.40	QPA8-300750X	59.15
.3000	.3220	1.000	.0080	.090	1.353	.1438	.3125	2.5	QPA8-3001000	52.40	QPA8-3001000X	59.65
.3600	.3820	.750	.0080	.110	.853	.1725	.3750	2.0	QPA8-360750	68.35	QPA8-360750X	76.45
.3600	.3820	1.000	.0080	.110	1.353	.1725	.3750	2.5	QPA8-3601000	68.35	QPA8-3601000X	76.95
.4100	.4320	.750	.0080	.120	1.040	.1600	.5000	2.5	QPA8-410750	95.75	QPA8-410750X	107.45
.4100	.4320	1.250	.0080	.120	1.540	.1600	.5000	3.0	QPA8-4101250	95.75	QPA8-4101250X	107.45
.4600	.4820	.750	.0080	.140	1.040	.2100	.5000	2.5	QPA8-460750	95.75	QPA8-460750X	107.45
.4600	.4820	1.000	.0080	.140	1.040	.2100	.5000	2.5	QPA8-4601000	95.75	QPA8-4601000X	107.45

*Suggested Minimum Bore Diameter to accommodate chip evacuation and retract clearance in static (not live) applications.

Quick Change – Profiling Tools



Find the Perfect Micro 100 Tool For Your Next Job With Product Table Filtering

On Micro100.com

Quick Change – Profiling Tools

QPF

Axial Profiling

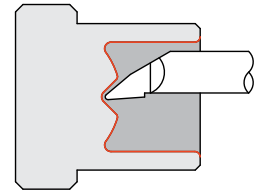
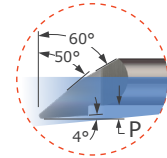
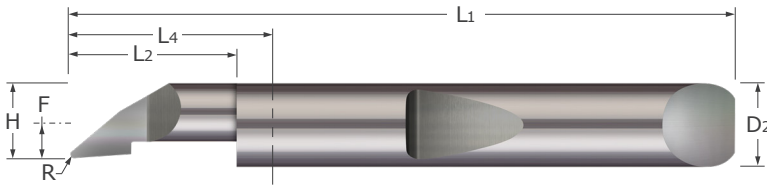

- Designed for both radial and axial profiling
- Unique design maximizes tool versatility and part feature creation
- Polished split face for improved edge retention and chip evacuation while reducing galling
- Split face geometry provides optimal edge strength
- Coolant fed enabled shank design
- Corner radius profile
- Proprietary Micro-Quik quick change system maximizes productivity through reliable accuracy and locational repeatability
- AlTiN coated option provides added lubricity and increased wear resistance in difficult to machine materials
- Solid carbide ■ CNC ground in the USA

Quick Change – Profiling Tools

Head Width	Min. Bore Diameter*	Max. Bore Depth	Radius	Projection	Length From Holder	Centerline Offset	Shank Dia.	Overall Length	Uncoated	AITiN Coated		
H		L2	R	P	L4	F	D2 (h6)	L1	Tool #	Price	Tool #	Price
.0500	.0550	.150	.0050	.005	.590	-.0438	.1875	1.5	QPF5-050150	33.60	QPF5-050150X	37.05
.0500	.0550	.200	.0050	.005	.590	-.0438	.1875	1.5	QPF-050200	33.60	QPF-050200X	37.05
.0500	.0550	.400	.0050	.005	.590	-.0438	.1875	1.5	QPF-050400	33.60	QPF-050400X	37.05
.0500	.0550	.500	.0050	.005	.590	-.0438	.1875	1.5	QPF-050500	33.60	QPF-050500X	37.05
.0600	.0700	.200	.0050	.005	.590	-.0338	.1875	1.5	QPF-060200	33.60	QPF-060200X	37.05
.0600	.0700	.400	.0050	.005	.590	-.0338	.1875	1.5	QPF-060400	33.60	QPF-060400X	37.05
.0600	.0700	.500	.0050	.005	.590	-.0338	.1875	1.5	QPF-060500	33.60	QPF-060500X	37.05
.0700	.0800	.150	.0050	.010	.590	-.0238	.1875	1.5	QPF5-070150	33.60	QPF5-070150X	37.05
.0700	.0800	.200	.0050	.010	.590	-.0238	.1875	1.5	QPF-070200	33.60	QPF-070200X	37.05
.0700	.0800	.300	.0050	.010	.590	-.0238	.1875	1.5	QPF5-070300	33.60	QPF5-070300X	37.05
.0700	.0800	.400	.0050	.010	.590	-.0238	.1875	1.5	QPF-070400	33.60	QPF-070400X	37.05
.0700	.0800	.500	.0050	.010	.590	-.0238	.1875	1.5	QPF-070500	33.60	QPF-070500X	37.05
.0700	.0800	.600	.0050	.010	1.090	-.0238	.1875	2.0	QPF-070600	33.60	QPF-070600X	37.05
.0800	.0900	.150	.0050	.010	.590	-.0138	.1875	1.5	QPF5-080150	33.60	QPF5-080150X	37.05
.0800	.0900	.200	.0050	.010	.590	-.0138	.1875	1.5	QPF5-080200	33.60	QPF5-080200X	37.05
.0800	.0900	.250	.0050	.010	.590	-.0138	.1875	1.5	QPF5-080250	33.60	QPF5-080250X	37.05
.0900	.1000	.200	.0050	.010	.590	-.0038	.1875	1.5	QPF5-090200	33.60	QPF5-090200X	37.05
.0900	.1000	.300	.0050	.010	.590	-.0038	.1875	1.5	QPF5-090300	33.60	QPF5-090300X	37.05
.1000	.1100	.300	.0050	.015	.590	.0063	.1875	1.5	QPF5-100300	33.60	QPF5-100300X	37.05
.1000	.1100	.400	.0050	.015	.590	.0063	.1875	1.5	QPF5-100400	33.60	QPF5-100400X	37.05
.1100	.1220	.250	.0050	.015	.590	.0163	.1875	1.5	QPF-110250	33.60	QPF-110250X	37.05
.1100	.1220	.375	.0050	.015	.590	.0163	.1875	1.5	QPF5-110375	33.60	QPF5-110375X	37.05
.1100	.1220	.500	.0050	.015	.590	.0163	.1875	1.5	QPF-110500	33.60	QPF-110500X	37.05
.1100	.1220	.750	.0050	.015	1.090	.0163	.1875	2.0	QPF-110750	33.60	QPF-110750X	37.05
.1200	.1320	.250	.0080	.020	.590	.0263	.1875	1.5	QPF-120250	33.60	QPF-120250X	37.05
.1200	.1320	.375	.0050	.020	.590	.0263	.1875	1.5	QPF5-120375	33.60	QPF5-120375X	37.05
.1200	.1320	.500	.0080	.020	.590	.0263	.1875	1.5	QPF-120500	33.60	QPF-120500X	37.05
.1200	.1320	.750	.0080	.020	1.090	.0263	.1875	2.0	QPF-120750	33.60	QPF-120750X	37.05
.1200	.1320	1.000	.0080	.020	1.090	.0263	.1875	2.0	QPF-1201000	33.60	QPF-1201000X	37.05

*Suggested Minimum Bore Diameter to accommodate chip evacuation and retract clearance in static (not live) applications.

Continued on next page

See pg 14-28 for quick change holder options

QPF

Quick Change – Profiling Tools

Axial Profiling (cont.)

Continued from previous page

Head Width	Min. Bore Diameter*	Max. Bore Depth	Radius	Projection	Length From Holder	Centerline Offset	Shank Dia.	Overall Length	Uncoated		AlTiN Coated	
									Tool #	Price	Tool #	Price
H		L ₂ $\begin{matrix} +.030" \\ -.000" \end{matrix}$	R $\begin{matrix} +.0005" \\ -.0005" \end{matrix}$	P	L ₄	F	D ₂ (h6)	L ₁				
.1400	.1520	.375	.0080	.020	.590	.0463	.1875	1.5	QPF8-140375	33.60	QPF8-140375X	37.05
.1400	.1520	.500	.0080	.020	.590	.0463	.1875	1.5	QPF8-140500	33.60	QPF8-140500X	37.05
.1600	.1760	.375	.0080	.030	.590	.0663	.1875	1.5	QPF8-160375	33.60	QPF8-160375X	37.05
.1600	.1760	.500	.0080	.030	.590	.0663	.1875	1.5	QPF-160500	33.60	QPF-160500X	37.05
.1600	.1760	.750	.0080	.030	1.090	.0663	.1875	2.0	QPF-160750	33.60	QPF-160750X	37.05
.1600	.1760	1.000	.0080	.030	1.090	.0663	.1875	2.0	QPF-1601000	33.60	QPF-1601000X	37.05
.1800	.1960	.375	.0080	.030	.853	.0550	.2500	2.0	QPF8-180375	42.00	QPF8-180375X	47.65
.1800	.1960	.500	.0080	.030	.853	.0550	.2500	2.0	QPF-180500	42.00	QPF-180500X	47.65
.1800	.1960	.750	.0080	.030	.853	.0550	.2500	2.0	QPF-180750	42.00	QPF-180750X	47.65
.1800	.1960	1.000	.0080	.030	1.353	.0550	.2500	2.5	QPF-1801000	42.00	QPF-1801000X	48.00
.2000	.2160	.400	.0080	.030	.853	.0750	.2500	2.0	QPF8-200400	42.00	QPF8-200400X	47.65
.2000	.2160	.600	.0080	.030	.853	.0750	.2500	2.0	QPF-200600	42.00	QPF-200600X	47.65
.2000	.2160	.800	.0080	.030	1.353	.0750	.2500	2.5	QPF8-200800	42.00	QPF8-200800X	48.00
.2000	.2160	1.000	.0080	.030	1.353	.0750	.2500	2.5	QPF-2001000	42.00	QPF-2001000X	48.00
.2300	.2500	.750	.0080	.030	.853	.0738	.3125	2.0	QPF-230750	52.40	QPF-230750X	59.15
.2300	.2500	1.000	.0080	.030	1.353	.0738	.3125	2.5	QPF-2301000	52.40	QPF-2301000X	59.65
.2300	.2500	1.100	.0080	.030	1.353	.0738	.3125	2.5	QPF-2301100	52.40	QPF-2301100X	59.65
.2300	.2500	1.250	.0080	.030	1.353	.0738	.3125	2.5	QPF-2301250	52.40	QPF-2301250X	59.65
.2600	.2800	.750	.0080	.030	.853	.1038	.3125	2.5	QPF8-260750	52.40	QPF8-260750X	59.65
.3000	.3200	1.000	.0080	.030	1.353	.1438	.3125	2.5	QPF-3001000	52.40	QPF-3001000X	59.65
.3000	.3200	1.250	.0080	.030	1.353	.1438	.3125	2.5	QPF-3001250	52.40	QPF-3001250X	59.65
.3600	.3800	.750	.0080	.030	.853	.1725	.3750	2.0	QPF8-360750	68.35	QPF8-360750X	75.70
.3600	.3800	1.000	.0080	.030	1.353	.1725	.3750	2.5	QPF-3601000	68.35	QPF-3601000X	76.95
.3600	.3800	1.250	.0080	.030	1.353	.1725	.3750	2.5	QPF-3601250	68.35	QPF-3601250X	76.95
.4100	.4300	.750	.0080	.040	1.040	.1600	.5000	2.5	QPF8-410750	95.75	QPF8-410750X	107.45
.4100	.4300	1.000	.0080	.040	1.040	.1600	.5000	2.5	QPF8-4101000	95.75	QPF8-4101000X	107.45
.4600	.4800	.750	.0080	.050	1.040	.2100	.5000	2.5	QPF8-460750	95.75	QPF8-460750X	107.45
.4600	.4800	1.000	.0080	.050	1.040	.2100	.5000	2.5	QPF-4601000	95.75	QPF-4601000X	107.45
.4600	.4800	1.600	.0080	.050	2.040	.2100	.5000	3.5			QPF-4601600X	110.30
.4900	.5100	1.800	.0080	.050	2.040	.2400	.5000	3.5			QPF-4901800X	110.30

*Suggested Minimum Bore Diameter to accommodate chip evacuation and retract clearance in static (not live) applications.

Quick Change – Profiling Tools

Quick Change – Grooving Tools

Retaining Ring – Square – Miniature

QMRR

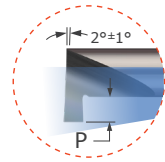
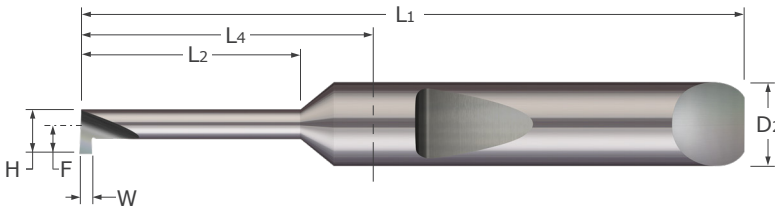

Quick Change – Grooving Tools

- Designed for generating retaining ring grooves in bores .070" and larger
- Polished face for improved edge retention and chip evacuation while reducing galling
- On-center neck design
- Coolant fed enabled shank design
- Sharp corner profile
- Proprietary Micro-Quik quick change system maximizes productivity through reliable accuracy and locational repeatability
- AITiN coated option provides added lubricity and increased wear resistance in difficult to machine materials
- Solid carbide ■ CNC ground in the USA

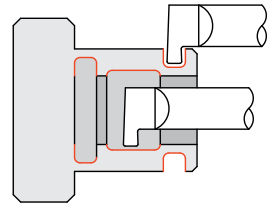

Width	Head Width	Minimum Bore Dia.*	Maximum Bore Depth	Proj.	Length From Holder	Centerline Offset	Shank Dia.	Overall Length	Uncoated		AITiN Coated	
W	H		L2	P	L4	F	D2 (h6)	L1	Tool #	Price	Tool #	Price
.10	.0600	.0700	.100	.020	.590	.0400	.1875	1.5	QMRR-010-100-060	46.75	QMRR-010-100-060X	50.65
.10	.0600	.0700	.150	.020	.590	.0400	.1875	1.5	QMRR-010-150-060	46.75	QMRR-010-150-060X	50.65
.10	.0600	.0700	.250	.020	.590	.0400	.1875	1.5	QMRR-010-250-060	46.75	QMRR-010-250-060X	50.65
.15	.0600	.0700	.100	.020	.590	.0400	.1875	1.5	QMRR-015-100-060	46.75	QMRR-015-100-060X	50.65
.15	.0600	.0700	.150	.020	.590	.0400	.1875	1.5	QMRR-015-150-060	46.75	QMRR-015-150-060X	50.65
.15	.0600	.0700	.250	.020	.590	.0400	.1875	1.5	QMRR-015-250-060	46.75	QMRR-015-250-060X	50.65
.15	.0800	.0900	.250	.025	.590	.0525	.1875	1.5	QMRR-015-250-080	46.75	QMRR-015-250-080X	50.65
.15	.0800	.0900	.375	.025	.590	.0525	.1875	1.5	QMRR-015-375-080	46.75	QMRR-015-375-080X	50.65
.15	.0800	.0900	.500	.025	.590	.0525	.1875	1.5	QMRR-015-500-080	46.75	QMRR-015-500-080X	50.65
.15	.1000	.1100	.250	.030	.590	.0650	.1875	1.5	QMRR-015-250-100	46.75	QMRR-015-250-100X	50.65
.15	.1000	.1100	.500	.030	.590	.0650	.1875	1.5	QMRR-015-500-100	46.75	QMRR-015-500-100X	50.65
.15	.1000	.1100	.750	.030	1.090	.0650	.1875	2.0	QMRR-015-750-100	46.75	QMRR-015-750-100X	50.65
.17	.1200	.1340	.150	.040	.590	.0800	.1875	1.5	QMRR-017-150-120	46.75	QMRR-017-150-120X	50.65
.17	.1200	.1340	.250	.040	.590	.0800	.1875	1.5	QMRR-017-250-120	46.75	QMRR-017-250-120X	50.65
.20	.0600	.0700	.100	.020	.590	.0400	.1875	1.5	QMRR-020-100-060	42.00	QMRR-020-100-060X	45.80
.20	.0600	.0700	.150	.020	.590	.0400	.1875	1.5	QMRR-020-150-060	42.00	QMRR-020-150-060X	45.80
.20	.0600	.0700	.250	.020	.590	.0400	.1875	1.5	QMRR-020-250-060	42.00	QMRR-020-250-060X	45.80
.20	.0700	.0800	.100	.020	.590	.0450	.1875	1.5	QMRR-020-100-070	42.00	QMRR-020-100-070X	45.80
.20	.0700	.0800	.150	.020	.590	.0450	.1875	1.5	QMRR-020-150-070	42.00	QMRR-020-150-070X	45.80
.20	.0800	.0900	.150	.025	.590	.0525	.1875	1.5	QMRR-020-150-080	42.00	QMRR-020-150-080X	45.80
.20	.0800	.0900	.250	.025	.590	.0525	.1875	1.5	QMRR-020-250-080	42.00	QMRR-020-250-080X	45.80
.20	.0800	.0900	.375	.025	.590	.0525	.1875	1.5	QMRR-020-375-080	42.00	QMRR-020-375-080X	45.80
.20	.0800	.0900	.500	.025	.590	.0525	.1875	1.5	QMRR-020-500-080	42.00	QMRR-020-500-080X	45.80
.20	.0900	.1000	.150	.025	.590	.0575	.1875	1.5	QMRR-020-150-090	42.00	QMRR-020-150-090X	45.80
.20	.0900	.1000	.250	.025	.590	.0575	.1875	1.5	QMRR-020-250-090	42.00	QMRR-020-250-090X	45.80
.20	.1000	.1100	.150	.030	.590	.0650	.1875	1.5	QMRR-020-150-100	42.00	QMRR-020-150-100X	45.80
.20	.1000	.1100	.250	.030	.590	.0650	.1875	1.5	QMRR-020-250-100	42.00	QMRR-020-250-100X	45.80
.20	.1000	.1100	.500	.030	.590	.0650	.1875	1.5	QMRR-020-500-100	42.00	QMRR-020-500-100X	45.80
.20	.1000	.1100	.750	.030	1.090	.0650	.1875	2.0	QMRR-020-750-100	42.00	QMRR-020-750-100X	45.80

*Suggested Minimum Bore Diameter to accommodate chip evacuation and retract clearance in static (not live) applications.

Continued on next page

See pg 14-28 for quick change holder options

QMRR

Quick Change – Grooving Tools
Retaining Ring – Square – Miniature (cont.)

Continued from previous page

Width W $\begin{smallmatrix} +.002" \\ -.000" \end{smallmatrix}$	Head Width H	Minimum Bore Dia.*	Maximum Bore Depth L ₂ $\begin{smallmatrix} +.030" \\ -.000" \end{smallmatrix}$	Proj. P	Length From Holder L ₄	Centerline Offset F	Shank Dia. D ₂ (h6)	Overall Length L ₁	Uncoated		AlTiN Coated	
									Tool #	Price	Tool #	Price
.020	.1200	.1340	.150	.040	.590	.0800	.1875	1.5	QMRR-020-150-120	42.00	QMRR-020-150-120X	45.80
.020	.1200	.1340	.250	.040	.590	.0800	.1875	1.5	QMRR-020-250-120	42.00	QMRR-020-250-120X	45.80
.020	.1200	.1340	.375	.040	.590	.0800	.1875	1.5	QMRR-020-375-120	42.00	QMRR-020-375-120X	45.80
.020	.1200	.1340	.500	.040	.590	.0800	.1875	1.5	QMRR-020-500-120	42.00	QMRR-020-500-120X	45.80
.020	.1200	.1340	.750	.040	1.090	.0800	.1875	2.0	QMRR-020-750-120	42.00	QMRR-020-750-120X	45.80
.025	.1200	.1340	.150	.040	.590	.0800	.1875	1.5	QMRR-025-150-120	42.00	QMRR-025-150-120X	45.80
.025	.1200	.1340	.250	.040	.590	.0800	.1875	1.5	QMRR-025-250-120	42.00	QMRR-025-250-120X	45.80
.030	.0700	.0800	.100	.020	.590	.0450	.1875	1.5	QMRR-030-100-070	42.00	QMRR-030-100-070X	45.80
.030	.0700	.0800	.150	.020	.590	.0450	.1875	1.5	QMRR-030-150-070	42.00	QMRR-030-150-070X	45.80
.030	.0800	.0900	.150	.025	.590	.0525	.1875	1.5	QMRR-030-150-080	42.00	QMRR-030-150-080X	45.80
.030	.0800	.0900	.250	.025	.590	.0525	.1875	1.5	QMRR-030-250-080	42.00	QMRR-030-250-080X	45.80
.030	.0800	.0900	.375	.025	.590	.0525	.1875	1.5	QMRR-030-375-080	42.00	QMRR-030-375-080X	45.80
.030	.0800	.0900	.500	.025	.590	.0525	.1875	1.5	QMRR-030-500-080	42.00	QMRR-030-500-080X	45.80
.030	.0900	.1000	.150	.025	.590	.0575	.1875	1.5	QMRR-030-150-090	42.00	QMRR-030-150-090X	45.80
.030	.0900	.1000	.250	.025	.590	.0575	.1875	1.5	QMRR-030-250-090	42.00	QMRR-030-250-090X	45.80
.030	.1000	.1100	.150	.030	.590	.0650	.1875	1.5	QMRR-030-150-100	42.00	QMRR-030-150-100X	45.80
.030	.1000	.1100	.250	.030	.590	.0650	.1875	1.5	QMRR-030-250-100	42.00	QMRR-030-250-100X	45.80
.030	.1000	.1100	.375	.030	.590	.0650	.1875	1.5	QMRR-030-375-100	42.00	QMRR-030-375-100X	45.80
.030	.1000	.1100	.500	.030	.590	.0650	.1875	1.5	QMRR-030-500-100	42.00	QMRR-030-500-100X	45.80
.030	.1000	.1100	.750	.030	1.090	.0650	.1875	2.0	QMRR-030-750-100	42.00	QMRR-030-750-100X	45.80
.030	.1200	.1340	.150	.040	.590	.0800	.1875	1.5	QMRR-030-150-120	42.00	QMRR-030-150-120X	45.80
.030	.1200	.1340	.250	.040	.590	.0800	.1875	1.5	QMRR-030-250-120	42.00	QMRR-030-250-120X	45.80
.030	.1200	.1340	.375	.040	.590	.0800	.1875	1.5	QMRR-030-375-120	42.00	QMRR-030-375-120X	45.80
.030	.1200	.1340	.500	.040	.590	.0800	.1875	1.5	QMRR-030-500-120	42.00	QMRR-030-500-120X	45.80
.030	.1200	.1340	.750	.040	1.090	.0800	.1875	2.0	QMRR-030-750-120	42.00	QMRR-030-750-120X	45.80

*Suggested Minimum Bore Diameter to accommodate chip evacuation and retract clearance in static (not live) applications.

Quick Change – Grooving Tools

Quick Change – Grooving Tools

QRR

Retaining Ring – Square

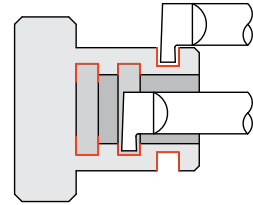
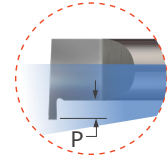
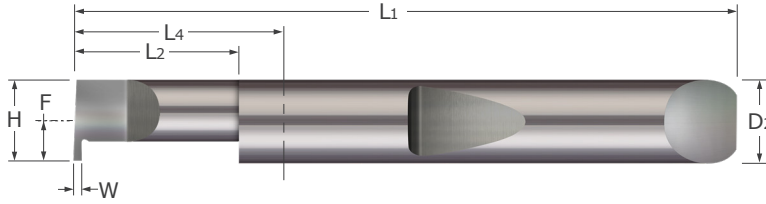

- Designed for generating retaining ring grooves in bores .134" and larger
- Polished split face for improved edge retention and chip evacuation while reducing galling
- Coolant fed enabled shank design
- Sharp corner profile
- Proprietary Micro-Quik quick change system maximizes productivity through reliable accuracy and locational repeatability
- AlTiN coated option provides added lubricity and increased wear resistance in difficult to machine materials
- Solid carbide ■ CNC ground in the USA

Quick Change – Grooving Tools

Width	Head Width	Minimum Bore Dia.*	Max. Bore Depth	Proj.	Length From Holder	Centerline Offset	Shank Dia.	Overall Length	Uncoated		AlTiN Coated	
									Tool #	Price	Tool #	Price
W $^{+.002"}_{-.000}"$	H		L2 $^{+.030"}_{-.000}"$	P	L4	F	D2 (h6)	L1				
.017	.1800	.1980	.250	.030	.590	.0863	.1875	1.5	QRR-017-4	35.70	QRR-017-4X	39.25
.017	.1800	.1980	.375	.030	.590	.0863	.1875	1.5	QRR-017-6	35.70	QRR-017-6X	39.25
.017	.1800	.1980	.500	.030	.590	.0863	.1875	1.5	QRR-017-8	35.70	QRR-017-8X	39.25
.017	.1800	.1980	.625	.030	1.090	.0863	.1875	2.0	QRR-017-10	35.70	QRR-017-10X	39.25
.017	.1800	.1980	.750	.030	1.090	.0863	.1875	2.0	QRR-017-750-180	35.70	QRR-017-750-180X	39.25
.017	.2450	.2670	.250	.050	.853	.1200	.2500	2.0	QRR-017-250-245	42.00	QRR-017-250-245X	47.65
.017	.2450	.2670	.375	.050	.853	.1200	.2500	2.0	QRR-017-375-245	42.00	QRR-017-375-245X	47.65
.020	.1200	.1340	.150	.030	.590	.0263	.1875	1.5	QRR-020-150-120	35.70	QRR-020-150-120X	39.25
.020	.1200	.1340	.250	.030	.590	.0263	.1875	1.5	QRR-020-250-120	35.70	QRR-020-250-120X	39.25
.020	.1400	.1540	.250	.030	.590	.0463	.1875	1.5	QRR-020-250-140	35.70	QRR-020-250-140X	39.25
.020	.1400	.1540	.375	.030	.590	.0463	.1875	1.5	QRR-020-375-140	35.70	QRR-020-375-140X	39.25
.020	.1600	.1780	.250	.030	.590	.0663	.1875	1.5	QRR-020-250-160	35.70	QRR-020-250-160X	39.25
.020	.1600	.1780	.375	.030	.590	.0663	.1875	1.5	QRR-020-375-160	35.70	QRR-020-375-160X	39.25
.020	.1800	.1980	.250	.030	.590	.0863	.1875	1.5	QRR-020-4	35.70	QRR-020-4X	39.25
.020	.1800	.1980	.375	.030	.590	.0863	.1875	1.5	QRR-020-6	35.70	QRR-020-6X	39.25
.020	.1800	.1980	.500	.030	.590	.0863	.1875	1.5	QRR-020-8	35.70	QRR-020-8X	39.25
.020	.1800	.1980	.625	.030	1.090	.0863	.1875	2.0	QRR-020-10	35.70	QRR-020-10X	39.25
.020	.1800	.1980	.750	.030	1.090	.0863	.1875	2.0	QRR-020-750-180	42.00	QRR-020-750-180X	46.75
.020	.2450	.2670	.250	.050	.853	.1200	.2500	2.0	QRR-020-250-245	42.00	QRR-020-250-245X	47.65
.020	.2450	.2670	.375	.050	.853	.1200	.2500	2.0	QRR-020-375-245	42.00	QRR-020-375-245X	47.65
.020	.2450	.2670	.500	.050	.853	.1200	.2500	2.0	QRR-020-500-245	42.00	QRR-020-500-245X	47.65
.020	.2450	.2670	.625	.050	.853	.1200	.2500	2.0	QRR-020-625-245	42.00	QRR-020-625-245X	47.65
.020	.3700	.3920	.625	.050	.853	.1825	.3750	2.0	QRR-020-625-370	68.35	QRR-020-625-370X	76.45
.020	.3700	.3920	1.000	.050	1.353	.1825	.3750	2.5	QRR-020-1000-370	68.35	QRR-020-1000-370X	76.95
.025	.2450	.2670	.250	.050	.853	.1200	.2500	2.0	QRR-025-4	42.00	QRR-025-4X	47.65
.025	.2450	.2670	.375	.050	.853	.1200	.2500	2.0	QRR-025-6	42.00	QRR-025-6X	47.65
.025	.2450	.2670	.500	.050	.853	.1200	.2500	2.0	QRR-025-8	42.00	QRR-025-8X	47.65
.025	.2450	.2670	.625	.050	.853	.1200	.2500	2.0	QRR-025-10	42.00	QRR-025-10X	47.65
.025	.2450	.2670	.750	.050	.853	.1200	.2500	2.0	QRR-025-750-245	42.00	QRR-025-750-245X	47.65
.030	.1200	.1340	.150	.030	.590	.0263	.1875	1.5	QRR-030-150-120	35.70	QRR-030-150-120X	39.25
.030	.1200	.1340	.250	.030	.590	.0263	.1875	1.5	QRR-030-250-120	35.70	QRR-030-250-120X	39.25
.030	.1400	.1540	.250	.030	.590	.0463	.1875	1.5	QRR-030-250-140	35.70	QRR-030-250-140X	39.25

*Suggested Minimum Bore Diameter to accommodate chip evacuation and retract clearance in static (not live) applications.

Continued on next page

See pg 14-28 for quick change holder options

See pg 68 for miniature sizes

QRR

Quick Change – Grooving Tools

Retaining Ring – Square (cont.)

Continued from previous page

Width	Head Width	Minimum Bore Dia.*	Max. Bore Depth	Proj.	Length From Holder	Centerline Offset	Shank Dia.	Overall Length	Uncoated		AlTiN Coated	
									Tool #	Price	Tool #	Price
W $\begin{matrix} +.002" \\ -.000" \end{matrix}$	H	L ₂ $\begin{matrix} +.030" \\ -.000" \end{matrix}$		P	L ₄	F	D ₂ (h6)	L ₁				
.030	.1400	.1540	.375	.030	.590	.0463	.1875	1.5	QRR-030-375-140	35.70	QRR-030-375-140X	39.25
.030	.1600	.1780	.250	.030	.590	.0663	.1875	1.5	QRR-030-250-160	35.70	QRR-030-250-160X	39.25
.030	.1600	.1780	.375	.030	.590	.0663	.1875	1.5	QRR-030-375-160	35.70	QRR-030-375-160X	39.25
.030	.1800	.1980	.250	.030	.590	.0863	.1875	1.5	QRR-030-250-180	35.70	QRR-030-250-180X	39.25
.030	.1800	.1980	.500	.030	.590	.0863	.1875	1.5	QRR-030-500-180	35.70	QRR-030-500-180X	39.25
.030	.2450	.2670	.250	.050	.853	.1200	.2500	2.0	QRR-030-4	42.00	QRR-030-4X	47.65
.030	.2450	.2670	.375	.050	.853	.1200	.2500	2.0	QRR-030-6	42.00	QRR-030-6X	47.65
.030	.2450	.2670	.500	.050	.853	.1200	.2500	2.0	QRR-030-8	42.00	QRR-030-8X	47.65
.030	.2450	.2670	.625	.050	.853	.1200	.2500	2.0	QRR-030-10	42.00	QRR-030-10X	47.65
.030	.2450	.2670	.750	.050	.853	.1200	.2500	2.0	QRR-030-750-245	42.00	QRR-030-750-245X	47.65
.030	.3100	.3320	.500	.100	.853	.1538	.3125	2.0	QRR-030-500-310	52.40	QRR-030-500-310X	59.15
.030	.3100	.3320	.750	.100	.853	.1538	.3125	2.0	QRR-030-750-310	52.40	QRR-030-750-310X	59.15
.030	.3700	.3920	.625	.050	.853	.1825	.3750	2.0	QRR-030-625-370	68.35	QRR-030-625-370X	76.45
.030	.3700	.3920	1.000	.050	1.353	.1825	.3750	2.5	QRR-030-1000-370	68.35	QRR-030-1000-370X	76.95
.033	.3100	.3320	.250	.100	.853	.1538	.3125	2.0	QRR-033-250-310	52.40	QRR-033-250-310X	59.15
.033	.3100	.3320	.375	.100	.853	.1538	.3125	2.0	QRR-033-6	52.40	QRR-033-6X	59.15
.033	.3100	.3320	.500	.100	.853	.1538	.3125	2.0	QRR-033-8	52.40	QRR-033-8X	59.15
.033	.3100	.3320	.750	.100	.853	.1538	.3125	2.0	QRR-033-12	52.40	QRR-033-12X	59.15
.038	.3100	.3320	.250	.100	.853	.1538	.3125	2.0	QRR-038-250-310	52.40	QRR-038-250-310X	59.15
.038	.3100	.3320	.375	.100	.853	.1538	.3125	2.0	QRR-038-6	52.40	QRR-038-6X	59.15
.038	.3100	.3320	.500	.100	.853	.1538	.3125	2.0	QRR-038-8	52.40	QRR-038-8X	59.15
.038	.3100	.3320	.750	.100	.853	.1538	.3125	2.0	QRR-038-12	52.40	QRR-038-12X	59.15
.039	.1800	.1980	.250	.030	.590	.0863	.1875	1.5	QRR-039-250-180	35.70	QRR-039-250-180X	39.25
.039	.1800	.1980	.500	.030	.590	.0863	.1875	1.5	QRR-039-500-180	35.70	QRR-039-500-180X	39.25
.039	.2450	.2670	.250	.050	.853	.1200	.2500	2.0	QRR-039-250-245	42.00	QRR-039-250-245X	47.65
.039	.2450	.2670	.500	.050	.853	.1200	.2500	2.0	QRR-039-500-245	42.00	QRR-039-500-245X	47.65
.039	.3700	.3920	.375	.100	.853	.1825	.3750	2.0	QRR-039-375-370	68.35	QRR-039-375-370X	75.70
.039	.3700	.3920	.500	.100	.853	.1825	.3750	2.0	QRR-039-8	68.35	QRR-039-8X	75.70
.039	.3700	.3920	.750	.100	.853	.1825	.3750	2.0	QRR-039-12	68.35	QRR-039-12X	75.70
.039	.3700	.3920	1.000	.100	1.353	.1825	.3750	2.5	QRR-039-16	68.35	QRR-039-16X	76.95
.039	.3700	.3920	1.250	.100	1.353	.1825	.3750	2.5	QRR-039-20	68.35	QRR-039-20X	76.95
.046	.3100	.3320	.500	.100	.853	.1538	.3125	2.0	QRR-046-500-310	52.40	QRR-046-500-310X	59.15
.046	.3100	.3320	.750	.100	.853	.1538	.3125	2.0	QRR-046-750-310	52.40	QRR-046-750-310X	59.15
.046	.3700	.3920	.375	.100	.853	.1825	.3750	2.0	QRR-046-375-370	68.35	QRR-046-375-370X	75.70
.046	.3700	.3920	.500	.100	.853	.1825	.3750	2.0	QRR-046-8	68.35	QRR-046-8X	75.70
.046	.3700	.3920	.750	.100	.853	.1825	.3750	2.0	QRR-046-12	68.35	QRR-046-12X	75.70
.046	.3700	.3920	1.000	.100	1.353	.1825	.3750	2.5	QRR-046-16	68.35	QRR-046-16X	76.95
.046	.3700	.3920	1.250	.100	1.353	.1825	.3750	2.5	QRR-046-20	68.35	QRR-046-20X	76.95
.055	.3700	.3920	.500	.100	.853	.1825	.3750	2.0	QRR-055-8	68.35	QRR-055-8X	75.70
.055	.3700	.3920	.750	.100	.853	.1825	.3750	2.0	QRR-055-12	68.35	QRR-055-12X	75.70
.055	.3700	.3920	1.000	.100	1.353	.1825	.3750	2.5	QRR-055-16	68.35	QRR-055-16X	76.95
.055	.3700	.3920	1.250	.100	1.353	.1825	.3750	2.5	QRR-055-20	68.35	QRR-055-20X	76.95
.059	.3700	.3920	.500	.100	.853	.1825	.3750	2.0	QRR-059-8	68.35	QRR-059-8X	75.70
.059	.3700	.3920	.750	.100	.853	.1825	.3750	2.0	QRR-059-12	68.35	QRR-059-12X	75.70
.059	.3700	.3920	1.000	.100	1.353	.1825	.3750	2.5	QRR-059-16	68.35	QRR-059-16X	76.95
.059	.3700	.3920	1.250	.100	1.353	.1825	.3750	2.5	QRR-059-20	68.35	QRR-059-20X	76.95

*Suggested Minimum Bore Diameter to accommodate chip evacuation and retract clearance in static (not live) applications.

Continued on next page

[See pg 14-28 for quick change holder options](#)

See pg 68 for miniature sizes

Quick Change – Grooving Tools

Quick Change – Grooving Tools

QRR

Retaining Ring – Square (cont.)

Continued from previous page

Width	Head Width	Minimum Bore Dia.*	Max. Bore Depth	Proj.	Length From Holder	Centerline Offset	Shank Dia.	Overall Length	Uncoated		AITIN Coated	
W $\begin{smallmatrix} +.002'' \\ -.000'' \end{smallmatrix}$	H		L ₂ $\begin{smallmatrix} +.030'' \\ -.000'' \end{smallmatrix}$	P	L ₄	F	D ₂ (h6)	L ₁	Tool #	Price	Tool #	Price
.062	.1800	.1980	.250	.030	.590	.0863	.1875	1.5	QRR-062-250-180	35.70	QRR-062-250-180X	39.25
.062	.1800	.1980	.500	.030	.590	.0863	.1875	1.5	QRR-062-500-180	35.70	QRR-062-500-180X	39.25
.062	.2450	.2670	.250	.050	.853	.1200	.2500	2.0	QRR-062-250-245	42.00	QRR-062-250-245X	47.65
.062	.2450	.2670	.500	.050	.853	.1200	.2500	2.0	QRR-062-500-245	42.00	QRR-062-500-245X	47.65
.062	.3100	.3320	.500	.100	.853	.1538	.3125	2.0	QRR-062-500-310	52.40	QRR-062-500-310X	59.15
.062	.3100	.3320	.750	.100	.853	.1538	.3125	2.0	QRR-062-750-310	52.40	QRR-062-750-310X	59.15
.062	.3700	.3920	.250	.100	.853	.1825	.3750	2.0	QRR-062-250-370	68.35	QRR-062-250-370X	75.70
.062	.3700	.3920	.375	.100	.853	.1825	.3750	2.0	QRR-062-375-370	68.35	QRR-062-375-370X	75.70
.062	.3700	.3920	.500	.100	.853	.1825	.3750	2.0	QRR-062-8	68.35	QRR-062-8X	75.70
.062	.3700	.3920	.750	.100	.853	.1825	.3750	2.0	QRR-062-12	68.35	QRR-062-12X	75.70
.062	.3700	.3920	1.000	.100	1.353	.1825	.3750	2.5	QRR-062-16	68.35	QRR-062-16X	76.95
.062	.3700	.3920	1.250	.100	1.353	.1825	.3750	2.5	QRR-062-20	68.35	QRR-062-20X	76.95
.069	.3700	.3920	.500	.100	.853	.1825	.3750	2.0	QRR-069-8	68.35	QRR-069-8X	75.70
.069	.3700	.3920	.750	.100	.853	.1825	.3750	2.0	QRR-069-12	68.35	QRR-069-12X	75.70
.069	.3700	.3920	1.000	.100	1.353	.1825	.3750	2.5	QRR-069-16	68.35	QRR-069-16X	76.95
.069	.3700	.3920	1.250	.100	1.353	.1825	.3750	2.5	QRR-069-20	68.35	QRR-069-20X	76.95
.079	.3700	.3920	.500	.100	.853	.1825	.3750	2.0	QRR-079-8	68.35	QRR-079-8X	75.70
.079	.3700	.3920	.750	.100	.853	.1825	.3750	2.0	QRR-079-12	68.35	QRR-079-12X	75.70
.079	.3700	.3920	1.000	.100	1.353	.1825	.3750	2.5	QRR-079-16	68.35	QRR-079-16X	76.95
.079	.3700	.3920	1.250	.100	1.353	.1825	.3750	2.5	QRR-079-20	68.35	QRR-079-20X	76.95
.087	.3100	.3320	.500	.100	.853	.1538	.3125	2.0	QRR-087-500-310	52.40	QRR-087-500-310X	59.15
.087	.3100	.3320	.750	.100	.853	.1538	.3125	2.0	QRR-087-750-310	52.40	QRR-087-750-310X	59.15
.087	.3700	.3920	.375	.100	.853	.1825	.3750	2.0	QRR-087-375-370	68.35	QRR-087-375-370X	75.70
.087	.3700	.3920	.500	.100	.853	.1825	.3750	2.0	QRR-087-8	68.35	QRR-087-8X	75.70
.087	.3700	.3920	.750	.100	.853	.1825	.3750	2.0	QRR-087-12	68.35	QRR-087-12X	75.70
.087	.3700	.3920	1.000	.100	1.353	.1825	.3750	2.5	QRR-087-16	68.35	QRR-087-16X	76.95
.087	.3700	.3920	1.250	.100	1.353	.1825	.3750	2.5	QRR-087-20	68.35	QRR-087-20X	76.95
.093	.4950	.5170	.750	.150	1.040	.2450	.5000	2.5	QRR-093-12	95.75	QRR-093-12X	107.45
.093	.4950	.5170	1.000	.150	1.040	.2450	.5000	2.5	QRR-093-16	95.75	QRR-093-16X	107.45
.093	.4950	.5170	1.250	.150	1.540	.2450	.5000	3.0	QRR-093-20	95.75	QRR-093-20X	107.45
.093	.4950	.5170	1.500	.150	1.540	.2450	.5000	3.0	QRR-093-24	95.75	QRR-093-24X	107.45
.118	.4950	.5170	.750	.150	1.040	.2450	.5000	2.5	QRR-118-12	95.75	QRR-118-12X	107.45
.118	.4950	.5170	1.000	.150	1.040	.2450	.5000	2.5	QRR-118-16	95.75	QRR-118-16X	107.45
.118	.4950	.5170	1.250	.150	1.540	.2450	.5000	3.0	QRR-118-20	95.75	QRR-118-20X	107.45
.118	.4950	.5170	1.500	.150	1.540	.2450	.5000	3.0	QRR-118-24	95.75	QRR-118-24X	107.45
.125	.3700	.3920	.750	.100	.853	.1825	.3750	2.0	QRR-125-750-370	68.35	QRR-125-750-370X	75.70
.125	.3700	.3920	1.000	.100	1.353	.1825	.3750	2.5	QRR-125-1000-370	68.35	QRR-125-1000-370X	76.95
.125	.3700	.3920	1.250	.100	1.353	.1825	.3750	2.5	QRR-125-1250-370	68.35	QRR-125-1250-370X	76.95
.125	.4950	.5170	.750	.150	1.040	.2450	.5000	2.5	QRR-125-12	95.75	QRR-125-12X	107.45
.125	.4950	.5170	1.000	.150	1.040	.2450	.5000	2.5	QRR-125-16	95.75	QRR-125-16X	107.45
.125	.4950	.5170	1.250	.150	1.540	.2450	.5000	3.0	QRR-125-20	95.75	QRR-125-20X	107.45
.125	.4950	.5170	1.500	.150	1.540	.2450	.5000	3.0	QRR-125-24	95.75	QRR-125-24X	107.45

*Suggested Minimum Bore Diameter to accommodate chip evacuation and retract clearance in static (not live) applications.

Continued on next page

See pg 14-28 for quick change holder options

See pg 68 for miniature sizes



QRR

Quick Change – Grooving Tools
Retaining Ring – Square (cont.)

Continued from previous page

Width	Head Width	Minimum Bore Dia.*	Max. Bore Depth	Proj.	Length From Holder	Centerline Offset	Shank Dia.	Overall Length	Uncoated		AlTiN Coated	
W $\begin{smallmatrix} +.002" \\ -.000" \end{smallmatrix}$	H		L2 $\begin{smallmatrix} +.030" \\ -.000" \end{smallmatrix}$	P	L4	F	D2 (h6)	L1	Tool #	Price	Tool #	Price
.156	.4950	.5170	.750	.150	1.040	.2450	.5000	2.5	QRR-156-12	95.75	QRR-156-12X	107.45
.156	.4950	.5170	1.000	.150	1.040	.2450	.5000	2.5	QRR-156-16	95.75	QRR-156-16X	107.45
.156	.4950	.5170	1.250	.150	1.540	.2450	.5000	3.0	QRR-156-20	95.75	QRR-156-20X	107.45
.156	.4950	.5170	1.500	.150	1.540	.2450	.5000	3.0	QRR-156-24	95.75	QRR-156-24X	107.45
.187	.4950	.5170	.750	.150	1.040	.2450	.5000	2.5	QRR-187-12	95.75	QRR-187-12X	107.45
.187	.4950	.5170	1.000	.150	1.040	.2450	.5000	2.5	QRR-187-16	95.75	QRR-187-16X	107.45
.187	.4950	.5170	1.250	.150	1.540	.2450	.5000	3.0	QRR-187-20	95.75	QRR-187-20X	107.45
.187	.4950	.5170	1.500	.150	1.540	.2450	.5000	3.0	QRR-187-24	95.75	QRR-187-24X	107.45
.236	.4950	.5170	.750	.150	1.040	.2450	.5000	2.5	QRR-236-12	95.75	QRR-236-12X	107.45
.236	.4950	.5170	1.000	.150	1.040	.2450	.5000	2.5	QRR-236-16	95.75	QRR-236-16X	107.45
.236	.4950	.5170	1.250	.150	1.540	.2450	.5000	3.0	QRR-236-20	95.75	QRR-236-20X	107.45
.236	.4950	.5170	1.500	.150	1.540	.2450	.5000	3.0	QRR-236-24	95.75	QRR-236-24X	107.45
.250	.4950	.5170	.750	.150	1.040	.2450	.5000	2.5	QRR-250-12	95.75	QRR-250-12X	107.45
.250	.4950	.5170	1.000	.150	1.040	.2450	.5000	2.5	QRR-250-16	95.75	QRR-250-16X	107.45
.250	.4950	.5170	1.250	.150	1.540	.2450	.5000	3.0	QRR-250-20	95.75	QRR-250-20X	107.45
.250	.4950	.5170	1.500	.150	1.540	.2450	.5000	3.0	QRR-250-24	95.75	QRR-250-24X	107.45

*Suggested Minimum Bore Diameter to accommodate chip evacuation and retract clearance in static (not live) applications.

Quick Change – Grooving Tools

See pg 14-28 for quick change holder options

See pg 68 for miniature sizes

Quick Change - Grooving Tools

Retaining Ring - Corner Radius - Right Hand

QRRC

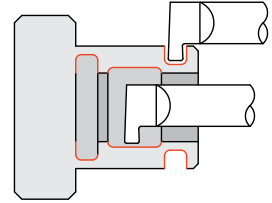
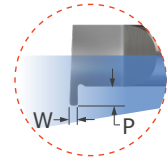
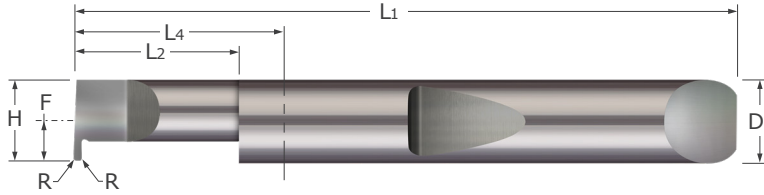

Quick Change - Grooving Tools

- Designed for generating corner radius retaining ring grooves in bores .198" and larger
- Corner radius designed for extended tool life and finished groove profiling
- Polished split face for improved edge retention and chip evacuation while reducing galling
- Coolant fed enabled shank design
- Proprietary Micro-Quik quick change system maximizes productivity through reliable accuracy and locational repeatability
- AlTiN coated option provides added lubricity and increased wear resistance in difficult to machine materials
- Solid carbide ■ CNC ground in the USA

Width	Head Width	Min. Bore Dia.*	Max. Bore Depth	Radius	Proj.	Length From Holder	Cntrln Offset	Shank Dia.	Overall Length	Uncoated		AlTiN Coated	
W ^{+0.001"} / _{-.000"}	H		L ₂ ^{+0.030"} / _{-.000"}	R ^{+0.001"} / _{-.001"}	P	L ₄	F	D ₂ (h6)	L ₁	Tool #	Price	Tool #	Price
.017	.1800	.1980	.250	.003	.030	.590	.0863	.1875	1.5	QRRC3-017-250-180	38.65	QRRC3-017-250-180X	42.25
.017	.1800	.1980	.375	.003	.030	.590	.0863	.1875	1.5	QRRC3-017-375-180	38.65	QRRC3-017-375-180X	42.25
.017	.2450	.2670	.250	.003	.050	.853	.1200	.2500	2.0	QRRC3-017-250-245	48.30	QRRC3-017-250-245X	53.95
.017	.2450	.2670	.375	.003	.050	.853	.1200	.2500	2.0	QRRC3-017-375-245	48.30	QRRC3-017-375-245X	53.95
.020	.1800	.1980	.250	.003	.030	.590	.0863	.1875	1.5	QRRC3-020-250-180	38.65	QRRC3-020-250-180X	42.25
.020	.1800	.1980	.375	.003	.030	.590	.0863	.1875	1.5	QRRC3-020-375-180	38.65	QRRC3-020-375-180X	42.25
.020	.2450	.2670	.250	.003	.050	.853	.1200	.2500	2.0	QRRC3-020-250-245	48.30	QRRC3-020-250-245X	53.95
.020	.2450	.2670	.375	.003	.050	.853	.1200	.2500	2.0	QRRC3-020-375-245	48.30	QRRC3-020-375-245X	53.95
.025	.2450	.2670	.250	.003	.050	.853	.1200	.2500	2.0	QRRC3-025-250-245	48.30	QRRC3-025-250-245X	53.95
.025	.2450	.2670	.375	.003	.050	.853	.1200	.2500	2.0	QRRC3-025-375-245	48.30	QRRC3-025-375-245X	53.95
.030	.1800	.1980	.250	.003	.030	.590	.0863	.1875	1.5	QRRC3-030-250-180	38.65	QRRC3-030-250-180X	42.25
.030	.1800	.1980	.500	.003	.030	.590	.0863	.1875	1.5	QRRC3-030-500-180	38.65	QRRC3-030-500-180X	42.25
.030	.2450	.2670	.250	.003	.050	.853	.1200	.2500	2.0	QRRC3-030-250-245	48.30	QRRC3-030-250-245X	53.95
.030	.2450	.2670	.375	.003	.050	.853	.1200	.2500	2.0	QRRC3-030-375-245	48.30	QRRC3-030-375-245X	53.95
.030	.3100	.3320	.500	.003	.100	.853	.1538	.3125	2.0	QRRC3-030-500-310	60.20	QRRC3-030-500-310X	67.05
.030	.3100	.3320	.750	.003	.100	.853	.1538	.3125	2.0	QRRC3-030-750-310	60.20	QRRC3-030-750-310X	67.05
.033	.3100	.3320	.500	.003	.100	.853	.1538	.3125	2.0	QRRC3-033-500-310	60.20	QRRC3-033-500-310X	67.05
.033	.3100	.3320	.750	.003	.100	.853	.1538	.3125	2.0	QRRC3-033-750-310	60.20	QRRC3-033-750-310X	67.05
.038	.3100	.3320	.500	.003	.100	.853	.1538	.3125	2.0	QRRC3-038-500-310	60.20	QRRC3-038-500-310X	67.05
.038	.3100	.3320	.750	.003	.100	.853	.1538	.3125	2.0	QRRC3-038-750-310	60.20	QRRC3-038-750-310X	67.05

W ^{+0.002"} / _{-.000"}	H		L ₂ ^{+0.030"} / _{-.000"}	R ^{+0.001"} / _{-.000"}	P	L ₄	F	D ₂ (h6)	L ₁	Tool #	Price	Tool #	Price
.039	.3700	.3920	.500	.003	.100	.853	.1825	.3750	2.0	QRRC3-039-500-370	76.25	QRRC3-039-500-370X	83.95
.039	.3700	.3920	.750	.003	.100	.853	.1825	.3750	2.0	QRRC3-039-750-370	76.25	QRRC3-039-750-370X	83.95
.039	.3700	.3920	1.000	.003	.100	1.353	.1825	.3750	2.5	QRRC3-039-1000-370	76.25	QRRC3-039-1000-370X	84.85
.062	.3700	.3920	.500	.003	.100	.853	.1825	.3750	2.0	QRRC3-062-500-370	76.25	QRRC3-062-500-370X	83.95
.062	.3700	.3920	.500	.006	.100	.853	.1825	.3750	2.0	QRRC6-062-500-370	76.25	QRRC6-062-500-370X	83.95
.062	.3700	.3920	.750	.003	.100	.853	.1825	.3750	2.0	QRRC3-062-750-370	76.25	QRRC3-062-750-370X	83.95
.062	.3700	.3920	.750	.006	.100	.853	.1825	.3750	2.0	QRRC6-062-750-370	76.25	QRRC6-062-750-370X	83.95
.062	.3700	.3920	1.000	.003	.100	1.353	.1825	.3750	2.5	QRRC3-062-1000-370	76.25	QRRC3-062-1000-370X	84.85
.062	.3700	.3920	1.000	.006	.100	1.353	.1825	.3750	2.5	QRRC6-062-1000-370	76.25	QRRC6-062-1000-370X	84.85

*Suggested Minimum Bore Diameter to accommodate chip evacuation and retract clearance in static (not live) applications.

Continued on next page

See pg 14-28 for quick change holder options

QRRC

Quick Change – Grooving Tools
Retaining Ring - Corner Radius - Right Hand (cont.)

Continued from previous page

Width	Head Width	Min. Bore Dia.*	Max. Bore Depth	Radius	Proj.	Length From Holder	Cntrln Offset	Shank Dia.	Overall Length	Uncoated		AITIN Coated	
										Tool #	Price	Tool #	Price
W $\begin{smallmatrix} +.002 \\ -.000 \end{smallmatrix}$ "	H		L ₂ $\begin{smallmatrix} +.030 \\ -.000 \end{smallmatrix}$ "	R $\begin{smallmatrix} +.001 \\ -.000 \end{smallmatrix}$ "	P	L ₄	F	D ₂ (h6)	L ₁				
.087	.3700	.3920	.500	.003	.100	.853	.1825	.3750	2.0	QRRC3-087-500-370	76.25	QRRC3-087-500-370X	83.95
.087	.3700	.3920	.500	.006	.100	.853	.1825	.3750	2.0	QRRC6-087-500-370	76.25	QRRC6-087-500-370X	83.95
.087	.3700	.3920	.750	.003	.100	.853	.1825	.3750	2.0	QRRC3-087-750-370	76.25	QRRC3-087-750-370X	83.95
.087	.3700	.3920	.750	.006	.100	.853	.1825	.3750	2.0	QRRC6-087-750-370	76.25	QRRC6-087-750-370X	83.95
.087	.3700	.3920	1.000	.003	.100	1.353	.1825	.3750	2.5	QRRC3-087-1000-370	76.25	QRRC3-087-1000-370X	84.85
.087	.3700	.3920	1.000	.006	.100	1.353	.1825	.3750	2.5	QRRC6-087-1000-370	76.25	QRRC6-087-1000-370X	84.85
.093	.4950	.5170	.750	.003	.150	1.040	.2450	.5000	2.5	QRRC3-093-750-495	104.85	QRRC3-093-750-495X	116.55
.093	.4950	.5170	.750	.006	.150	1.040	.2450	.5000	2.5	QRRC6-093-750-495	104.85	QRRC6-093-750-495X	116.55
.093	.4950	.5170	1.000	.003	.150	1.040	.2450	.5000	2.5	QRRC3-093-1000-495	104.85	QRRC3-093-1000-495X	116.55
.093	.4950	.5170	1.000	.006	.150	1.040	.2450	.5000	2.5	QRRC6-093-1000-495	104.85	QRRC6-093-1000-495X	116.55
.125	.4950	.5170	.750	.003	.150	1.040	.2450	.5000	2.5	QRRC3-125-750-495	104.85	QRRC3-125-750-495X	116.55
.125	.4950	.5170	.750	.006	.150	1.040	.2450	.5000	2.5	QRRC6-125-750-495	104.85	QRRC6-125-750-495X	116.55
.125	.4950	.5170	1.000	.003	.150	1.040	.2450	.5000	2.5	QRRC3-125-1000-495	104.85	QRRC3-125-1000-495X	116.55
.125	.4950	.5170	1.000	.006	.150	1.040	.2450	.5000	2.5	QRRC6-125-1000-495	104.85	QRRC6-125-1000-495X	116.55

*Suggested Minimum Bore Diameter to accommodate chip evacuation and retract clearance in static (not live) applications.

Quick Change – Grooving Tools

Full Radius – Miniature

QMFR

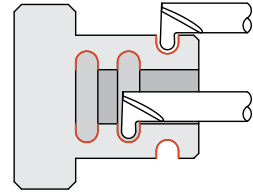
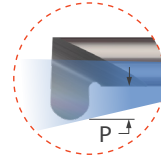
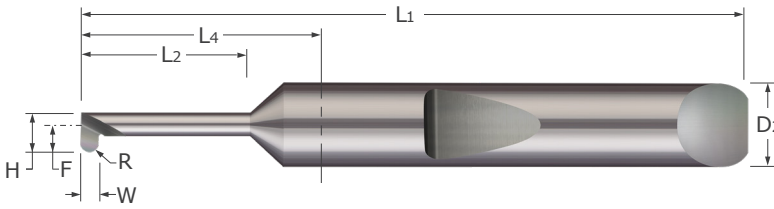

Quick Change – Grooving Tools

- Designed for generating full radius grooves in bores .090" and larger
- Polished face for improved edge retention and chip evacuation while reducing galling
- On-center neck design
- Coolant fed enabled shank design
- Full radius profile
- Proprietary Micro-Quik quick change system maximizes productivity through reliable accuracy and locational repeatability
- AlTiN coated option provides added lubricity and increased wear resistance in difficult to machine materials
- Solid carbide ■ CNC ground in the USA

Width	Radius	Head Width	Mini. Bore Dia.*	Max. Bore Depth	Proj.	Length From Holder	Centerline Offset	Shank Dia.	Overall Length	Uncoated		AlTiN Coated	
W ^{+0.002"} / _{-.000"}	R ^{+0.001"} / _{-.000"}	H		L2 ^{+0.030"} / _{-.000"}	P	L4	F	D2 (h6)	L1	Tool #	Price	Tool #	Price
.015	.0075	.0800	.0900	.250	.025	.590	.0525	.1875	1.5	QMFR-015-250-080	46.75	QMFR-015-250-080X	50.65
.015	.0075	.0800	.0900	.375	.025	.590	.0525	.1875	1.5	QMFR-015-375-080	46.75	QMFR-015-375-080X	50.65
.015	.0075	.0800	.0900	.500	.025	.590	.0525	.1875	1.5	QMFR-015-500-080	46.75	QMFR-015-500-080X	50.65
.015	.0075	.1000	.1100	.250	.030	.590	.0650	.1875	1.5	QMFR-015-250-100	46.75	QMFR-015-250-100X	50.65
.015	.0075	.1000	.1100	.500	.030	.590	.0650	.1875	1.5	QMFR-015-500-100	46.75	QMFR-015-500-100X	50.65
.015	.0075	.1000	.1100	.750	.030	1.090	.0650	.1875	2.0	QMFR-015-750-100	46.75	QMFR-015-750-100X	50.65
.020	.0100	.0800	.0900	.250	.025	.590	.0525	.1875	1.5	QMFR-020-250-080	42.00	QMFR-020-250-080X	45.80
.020	.0100	.0800	.0900	.375	.025	.590	.0525	.1875	1.5	QMFR-020-375-080	42.00	QMFR-020-375-080X	45.80
.020	.0100	.0800	.0900	.500	.025	.590	.0525	.1875	1.5	QMFR-020-500-080	42.00	QMFR-020-500-080X	45.80
.020	.0100	.1000	.1100	.250	.030	.590	.0650	.1875	1.5	QMFR-020-250-100	42.00	QMFR-020-250-100X	45.80
.020	.0100	.1000	.1100	.500	.030	.590	.0650	.1875	1.5	QMFR-020-500-100	42.00	QMFR-020-500-100X	45.80
.020	.0100	.1000	.1100	.750	.030	1.090	.0650	.1875	2.0	QMFR-020-750-100	42.00	QMFR-020-750-100X	45.80
.020	.0100	.1200	.1340	.250	.040	.590	.0800	.1875	1.5	QMFR-020-250-120	42.00	QMFR-020-250-120X	45.80
.020	.0100	.1200	.1340	.500	.040	.590	.0800	.1875	1.5	QMFR-020-500-120	42.00	QMFR-020-500-120X	45.80
.020	.0100	.1200	.1340	.750	.040	1.090	.0800	.1875	2.0	QMFR-020-750-120	42.00	QMFR-020-750-120X	45.80
.030	.0150	.0800	.0900	.250	.025	.590	.0525	.1875	1.5	QMFR-030-250-080	42.00	QMFR-030-250-080X	45.80
.030	.0150	.0800	.0900	.375	.025	.590	.0525	.1875	1.5	QMFR-030-375-080	42.00	QMFR-030-375-080X	45.80
.030	.0150	.0800	.0900	.500	.025	.590	.0525	.1875	1.5	QMFR-030-500-080	42.00	QMFR-030-500-080X	45.80
.030	.0150	.1000	.1100	.250	.030	.590	.0650	.1875	1.5	QMFR-030-250-100	42.00	QMFR-030-250-100X	45.80
.030	.0150	.1000	.1100	.500	.030	.590	.0650	.1875	1.5	QMFR-030-500-100	42.00	QMFR-030-500-100X	45.80
.030	.0150	.1000	.1100	.750	.030	1.090	.0650	.1875	2.0	QMFR-030-750-100	42.00	QMFR-030-750-100X	45.80
.030	.0150	.1200	.1340	.250	.040	.590	.0800	.1875	1.5	QMFR-030-250-120	42.00	QMFR-030-250-120X	45.80
.030	.0150	.1200	.1340	.500	.040	.590	.0800	.1875	1.5	QMFR-030-500-120	42.00	QMFR-030-500-120X	45.80
.030	.0150	.1200	.1340	.750	.040	1.090	.0800	.1875	2.0	QMFR-030-750-120	42.00	QMFR-030-750-120X	45.80

*Suggested Minimum Bore Diameter to accommodate chip evacuation and retract clearance in static (not live) applications.

See pg 14-28 for quick change holder options

QFR

Quick Change – Grooving Tools

Full Radius

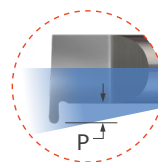
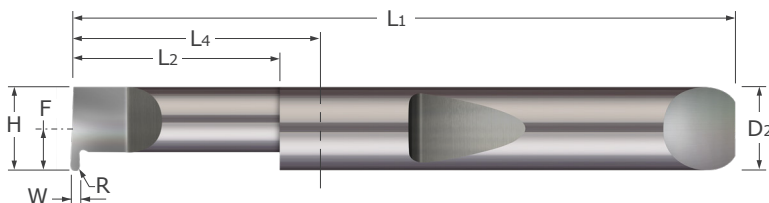

- Designed for generating full radius grooves in bores .198" and larger
- Polished split face for improved edge retention and chip evacuation while reducing galling
- Coolant fed enabled shank design
- Full radius profile
- Proprietary Micro-Quik quick change system maximizes productivity through reliable accuracy and locational repeatability
- AlTiN coated option provides added lubricity and increased wear resistance in difficult to machine materials
- Solid carbide ■ CNC ground in the USA

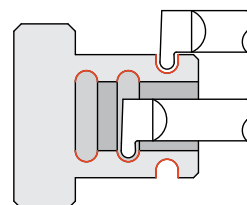

Quick Change – Grooving Tools

Width	Radius	Head Width	Min. Bore Dia.*	Max. Bore Depth	Projection	Length From Holder	Centerline Offset	Shank Dia.	Overall Length	Uncoated		AlTiN Coated	
										Tool #	Price	Tool #	Price
W $^{+.002"}_{-.000"}$	R	H		L2 $^{+.030"}_{-.000"}$	P	L4	F	D2 (h6)	L1				
.017	.0085	.1800	.1980	.250	.030	.590	.0863	.1875	1.5	QFR-017-4	38.65	QFR-017-4X	42.25
.017	.0085	.1800	.1980	.375	.030	.590	.0863	.1875	1.5	QFR-017-6	38.65	QFR-017-6X	42.25
.017	.0085	.1800	.1980	.500	.030	.590	.0863	.1875	1.5	QFR-017-8	38.65	QFR-017-8X	42.25
.017	.0085	.1800	.1980	.625	.030	1.090	.0863	.1875	2.0	QFR-017-10	38.65	QFR-017-10X	42.25
.020	.0100	.1800	.1980	.250	.030	.590	.0863	.1875	1.5	QFR-020-4	38.65	QFR-020-4X	42.25
.020	.0100	.1800	.1980	.375	.030	.590	.0863	.1875	1.5	QFR-020-6	38.65	QFR-020-6X	42.25
.020	.0100	.1800	.1980	.500	.030	.590	.0863	.1875	1.5	QFR-020-8	38.65	QFR-020-8X	42.25
.020	.0100	.1800	.1980	.625	.030	1.090	.0863	.1875	2.0	QFR-020-10	38.65	QFR-020-10X	42.25
.025	.0125	.2450	.2670	.250	.050	.853	.1200	.2500	2.0	QFR-025-4	48.30	QFR-025-4X	53.95
.025	.0125	.2450	.2670	.375	.050	.853	.1200	.2500	2.0	QFR-025-6	48.30	QFR-025-6X	53.95
.025	.0125	.2450	.2670	.500	.050	.853	.1200	.2500	2.0	QFR-025-8	48.30	QFR-025-8X	53.95
.025	.0125	.2450	.2670	.625	.050	.853	.1200	.2500	2.0	QFR-025-10	48.30	QFR-025-10X	53.95
.030	.0150	.2450	.2670	.250	.050	.853	.1200	.2500	2.0	QFR-030-4	48.30	QFR-030-4X	53.95
.030	.0150	.2450	.2670	.375	.050	.853	.1200	.2500	2.0	QFR-030-6	48.30	QFR-030-6X	53.95
.030	.0150	.2450	.2670	.500	.050	.853	.1200	.2500	2.0	QFR-030-8	48.30	QFR-030-8X	53.95
.030	.0150	.2450	.2670	.625	.050	.853	.1200	.2500	2.0	QFR-030-10	48.30	QFR-030-10X	53.95
.033	.0165	.3100	.3320	.375	.100	.853	.1538	.3125	2.0	QFR-033-6	60.20	QFR-033-6X	67.05
.033	.0165	.3100	.3320	.500	.100	.853	.1538	.3125	2.0	QFR-033-8	60.20	QFR-033-8X	67.05
.033	.0165	.3100	.3320	.750	.100	.853	.1538	.3125	2.0	QFR-033-12	60.20	QFR-033-12X	67.05
.038	.0190	.3100	.3320	.375	.100	.853	.1538	.3125	2.0	QFR-038-6	60.20	QFR-038-6X	67.05
.038	.0190	.3100	.3320	.500	.100	.853	.1538	.3125	2.0	QFR-038-8	60.20	QFR-038-8X	67.05
.038	.0190	.3100	.3320	.750	.100	.853	.1538	.3125	2.0	QFR-038-12	60.20	QFR-038-12X	67.05
.039	.0195	.3700	.3920	.500	.100	.853	.1825	.3750	2.0	QFR-039-8	76.25	QFR-039-8X	83.95
.039	.0195	.3700	.3920	.750	.100	.853	.1825	.3750	2.0	QFR-039-12	76.25	QFR-039-12X	83.95
.039	.0195	.3700	.3920	1.000	.100	1.353	.1825	.3750	2.5	QFR-039-16	76.25	QFR-039-16X	84.85
.039	.0195	.3700	.3920	1.250	.100	1.353	.1825	.3750	2.5	QFR-039-20	76.25	QFR-039-20X	84.85
.046	.0230	.3700	.3920	.500	.100	.853	.1825	.3750	2.0	QFR-046-8	76.25	QFR-046-8X	83.95
.046	.0230	.3700	.3920	.750	.100	.853	.1825	.3750	2.0	QFR-046-12	76.25	QFR-046-12X	83.95
.046	.0230	.3700	.3920	1.000	.100	1.353	.1825	.3750	2.5	QFR-046-16	76.25		
.046	.0230	.3700	.3920	1.250	.100	1.353	.1825	.3750	2.5	QFR-046-20	76.25	QFR-046-20X	84.85
.055	.0275	.3700	.3920	.500	.100	.853	.1825	.3750	2.0	QFR-055-8	76.25	QFR-055-8X	83.95
.055	.0275	.3700	.3920	.750	.100	.853	.1825	.3750	2.0	QFR-055-12	76.25	QFR-055-12X	83.95
.055	.0275	.3700	.3920	1.000	.100	1.353	.1825	.3750	2.5	QFR-055-16	76.25	QFR-055-16X	84.85
.055	.0275	.3700	.3920	1.250	.100	1.353	.1825	.3750	2.5	QFR-055-20	76.25	QFR-055-20X	84.85

*Suggested Minimum Bore Diameter to accommodate chip evacuation and retract clearance in static (not live) applications.

Continued on next page

See pg 14-28 for quick change holder options

See pg 76 for miniature sizes

Quick Change – Grooving Tools

QFR

Full Radius (cont.)

Continued from previous page

Width	Radius	Head Width	Min. Bore Dia.*	Max. Bore Depth	Projection	Length From Holder	Centerline Offset	Shank Dia.	Overall Length	Uncoated		AlTiN Coated	
W $\begin{smallmatrix} +.002" \\ -.000" \end{smallmatrix}$	R	H		L ₂ $\begin{smallmatrix} +.030" \\ -.000" \end{smallmatrix}$	P	L ₄	F	D ₂ (h6)	L ₁	Tool #	Price	Tool #	Price
.059	.0295	.3700	.3920	.500	.100	.853	.1825	.3750	2.0	QFR-059-8	76.25	QFR-059-8X	83.95
.059	.0295	.3700	.3920	.750	.100	.853	.1825	.3750	2.0	QFR-059-12	76.25	QFR-059-12X	83.95
.059	.0295	.3700	.3920	1.000	.100	1.353	.1825	.3750	2.5	QFR-059-16	76.25	QFR-059-16X	84.85
.059	.0295	.3700	.3920	1.250	.100	1.353	.1825	.3750	2.5	QFR-059-20	76.25	QFR-059-20X	84.85
.062	.0310	.3700	.3920	.500	.100	.853	.1825	.3750	2.0	QFR-062-8	76.25	QFR-062-8X	83.95
.062	.0310	.3700	.3920	.750	.100	.853	.1825	.3750	2.0	QFR-062-12	76.25	QFR-062-12X	83.95
.062	.0310	.3700	.3920	1.000	.100	1.353	.1825	.3750	2.5	QFR-062-16	76.25	QFR-062-16X	84.85
.062	.0310	.3700	.3920	1.250	.100	1.353	.1825	.3750	2.5	QFR-062-20	76.25	QFR-062-20X	84.85
.069	.0345	.3700	.3920	.500	.100	.853	.1825	.3750	2.0	QFR-069-8	76.25	QFR-069-8X	83.95
.069	.0345	.3700	.3920	.750	.100	.853	.1825	.3750	2.0	QFR-069-12	76.25	QFR-069-12X	83.95
.069	.0345	.3700	.3920	1.000	.100	1.353	.1825	.3750	2.5	QFR-069-16	76.25	QFR-069-16X	84.85
.069	.0345	.3700	.3920	1.250	.100	1.353	.1825	.3750	2.5	QFR-069-20	76.25	QFR-069-20X	84.85
.079	.0395	.3700	.3920	.500	.100	.853	.1825	.3750	2.0	QFR-079-8	76.25	QFR-079-8X	83.95
.079	.0395	.3700	.3920	.750	.100	.853	.1825	.3750	2.0	QFR-079-12	76.25	QFR-079-12X	83.95
.079	.0395	.3700	.3920	1.000	.100	1.353	.1825	.3750	2.5	QFR-079-16	76.25	QFR-079-16X	84.85
.079	.0395	.3700	.3920	1.250	.100	1.353	.1825	.3750	2.5	QFR-079-20	76.25	QFR-079-20X	84.85
.087	.0435	.3700	.3920	.500	.100	.853	.1825	.3750	2.0	QFR-087-8	76.25	QFR-087-8X	83.95
.087	.0435	.3700	.3920	.750	.100	.853	.1825	.3750	2.0	QFR-087-12	76.25	QFR-087-12X	83.95
.087	.0435	.3700	.3920	1.000	.100	1.353	.1825	.3750	2.5	QFR-087-16	76.25	QFR-087-16X	84.85
.087	.0435	.3700	.3920	1.250	.100	1.353	.1825	.3750	2.5	QFR-087-20	76.25	QFR-087-20X	84.85
.093	.0465	.4950	.5170	.750	.150	1.040	.2450	.5000	2.5	QFR-093-12	104.85	QFR-093-12X	116.55
.093	.0465	.4950	.5170	1.000	.150	1.040	.2450	.5000	2.5	QFR-093-16	104.85	QFR-093-16X	116.55
.093	.0465	.4950	.5170	1.250	.150	1.540	.2450	.5000	3.0	QFR-093-20	104.85	QFR-093-20X	116.55
.093	.0465	.4950	.5170	1.500	.150	1.540	.2450	.5000	3.0	QFR-093-24	104.85	QFR-093-24X	116.55
.118	.0590	.4950	.5170	.750	.150	1.040	.2450	.5000	2.5	QFR-118-12	104.85	QFR-118-12X	116.55
.118	.0590	.4950	.5170	1.000	.150	1.040	.2450	.5000	2.5	QFR-118-16	104.85	QFR-118-16X	116.55
.118	.0590	.4950	.5170	1.250	.150	1.540	.2450	.5000	3.0	QFR-118-20	104.85	QFR-118-20X	116.55
.118	.0590	.4950	.5170	1.500	.150	1.540	.2450	.5000	3.0	QFR-118-24	104.85	QFR-118-24X	116.55
.125	.0625	.4950	.5170	.750	.150	1.040	.2450	.5000	2.5	QFR-125-12	104.85	QFR-125-12X	116.55
.125	.0625	.4950	.5170	1.000	.150	1.040	.2450	.5000	2.5	QFR-125-16	104.85	QFR-125-16X	116.55
.125	.0625	.4950	.5170	1.250	.150	1.540	.2450	.5000	3.0	QFR-125-20	104.85	QFR-125-20X	116.55
.125	.0625	.4950	.5170	1.500	.150	1.540	.2450	.5000	3.0	QFR-125-24	104.85	QFR-125-24X	116.55
.156	.0780	.4950	.5170	.750	.150	1.040	.2450	.5000	2.5			QFR-156-12X	116.55
.156	.0780	.4950	.5170	1.000	.150	1.040	.2450	.5000	2.5			QFR-156-16X	116.55
.156	.0780	.4950	.5170	1.250	.150	1.540	.2450	.5000	3.0	QFR-156-20	104.85	QFR-156-20X	116.55
.156	.0780	.4950	.5170	1.500	.150	1.540	.2450	.5000	3.0	QFR-156-24	104.85	QFR-156-24X	116.55
.187	.0935	.4950	.5170	.750	.150	1.040	.2450	.5000	2.5	QFR-187-12	104.85	QFR-187-12X	116.55
.187	.0935	.4950	.5170	1.000	.150	1.040	.2450	.5000	2.5	QFR-187-16	104.85	QFR-187-16X	116.55
.187	.0935	.4950	.5170	1.250	.150	1.540	.2450	.5000	3.0	QFR-187-20	104.85	QFR-187-20X	116.55
.187	.0935	.4950	.5170	1.500	.150	1.540	.2450	.5000	3.0	QFR-187-24	104.85	QFR-187-24X	116.55
.236	.1180	.4950	.5170	.750	.150	1.040	.2450	.5000	2.5	QFR-236-12	104.85	QFR-236-12X	116.55
.236	.1180	.4950	.5170	1.000	.150	1.040	.2450	.5000	2.5	QFR-236-16	104.85	QFR-236-16X	116.55
.236	.1180	.4950	.5170	1.250	.150	1.540	.2450	.5000	3.0	QFR-236-20	104.85	QFR-236-20X	116.55
.236	.1180	.4950	.5170	1.500	.150	1.540	.2450	.5000	3.0	QFR-236-24	104.85	QFR-236-24X	116.55
.250	.1250	.4950	.5170	.750	.150	1.040	.2450	.5000	2.5	QFR-250-12	104.85	QFR-250-12X	116.55
.250	.1250	.4950	.5170	1.000	.150	1.040	.2450	.5000	2.5	QFR-250-16	104.85	QFR-250-16X	116.55
.250	.1250	.4950	.5170	1.250	.150	1.540	.2450	.5000	3.0	QFR-250-20	104.85	QFR-250-20X	116.55
.250	.1250	.4950	.5170	1.500	.150	1.540	.2450	.5000	3.0	QFR-250-24	104.85	QFR-250-24X	116.55

*Suggested Minimum Bore Diameter to accommodate chip evacuation and retract clearance in static (not live) applications.

See pg 14-28 for quick change holder options

See pg 76 for miniature sizes

QUP

Quick Change – Grooving Tools

Undercutting – Full Radius

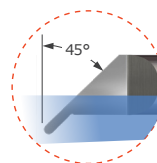
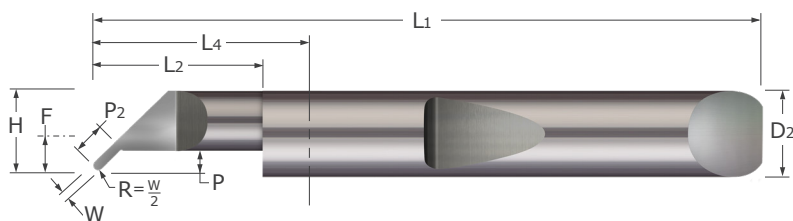

- Designed for plunging full radius undercut grooves and profiling
- Polished split face for improved edge retention and chip evacuation while reducing galling
- Full radius profile
- Coolant fed enabled shank design
- Proprietary Micro-Quik quick change system maximizes productivity through reliable accuracy and locational repeatability
- AlTiN coated option provides added lubricity and increased wear resistance in difficult to machine materials
- Solid carbide ■ CNC ground in the USA

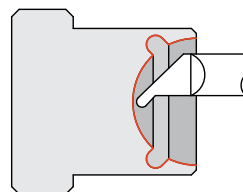

Quick Change – Grooving Tools

Width	Projection	Angled Projection	Head Width	Min. Bore Diameter*	Max. Bore Depth	Length From Holder	Centerline Offset	Shank Dia.	Overall Length	Uncoated		AlTiN Coated	
W ^{+0.002"} / _{-.000"}	P	P2	H		L2 ^{+0.030"} / _{-.000"}	L4	F	D2 (h6)	L1	Tool #	Price	Tool #	Price
.020	.050	.0765	.1800	.1980	.375	.590	.0863	.1875	1.5	QUP-18020-6	44.75	QUP-18020-6X	49.50
.020	.050	.0765	.1800	.1980	.500	.590	.0863	.1875	1.5	QUP-18020-8	44.75	QUP-18020-8X	49.50
.025	.050	.0780	.1800	.1980	.375	.590	.0863	.1875	1.5	QUP-18025-6	44.75	QUP-18025-6X	49.50
.025	.050	.0780	.1800	.1980	.500	.590	.0863	.1875	1.5	QUP-18025-8	44.75	QUP-18025-8X	49.50
.025	.060	.0921	.2400	.2620	.375	.853	.1150	.2500	2.0	QUP-25025-6	48.20	QUP-25025-6X	53.85
.025	.060	.0921	.2400	.2620	.500	.853	.1150	.2500	2.0	QUP-25025-8	48.20	QUP-25025-8X	53.85
.030	.050	.0794	.1800	.1980	.375	.590	.0863	.1875	1.5	QUP-18030-6	44.75	QUP-18030-6X	49.50
.030	.050	.0794	.1800	.1980	.500	.590	.0863	.1875	1.5	QUP-18030-8	44.75	QUP-18030-8X	49.50
.030	.060	.0936	.2400	.2620	.500	.853	.1150	.2500	2.0	QUP-25030-8	48.20	QUP-25030-8X	53.85
.030	.060	.0936	.2400	.2620	1.000	1.353	.1150	.2500	2.5	QUP-25030-16	48.20	QUP-25030-16X	54.25
.062	.083	.1355	.3030	.3250	1.000	1.353	.1468	.3125	2.5	QUP-31062-16	60.50	QUP-31062-16X	67.75
.062	.095	.1525	.3650	.3870	1.000	1.353	.1775	.3750	2.5	QUP-37062-16	77.85	QUP-37062-16X	86.45
.062	.125	.1949	.4900	.5120	1.500	1.853	.2400	.5000	3.0	QUP-50062-24	107.45	QUP-50062-24X	119.15

*Suggested Minimum Bore Diameter to accommodate chip evacuation and retract clearance in static (not live) applications.

Quick Change – Grooving Tools

QFG

Face Grooving – Square

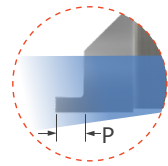
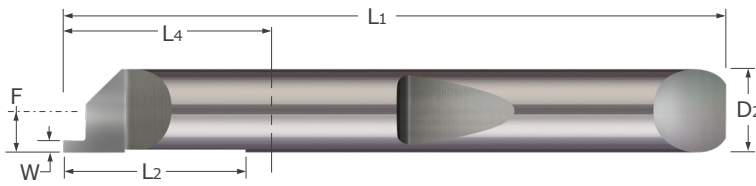

- Designed for generating square grooves in the face of the part
- Polished split face for improved edge retention and chip evacuation while reducing galling
- Split face geometry provides optimal edge strength
- Relief ground along Maximum Bore Depth (L2) to avoid interference during deep hole applications
- Coolant fed enabled shank design
- Sharp corner profile
- Proprietary Micro-Quik quick change system maximizes productivity through reliable accuracy and locational repeatability
- AlTiN coated option provides added lubricity and increased wear resistance in difficult to machine materials
- Solid carbide ■ CNC ground in the USA

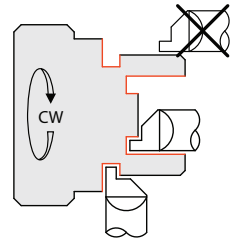

Quick Change – Grooving Tools

Width	Projection	Minimum Groove Diameter*	Maximum Bore Depth	Length From Holder	Centerline Offset	Shank Diameter	Overall Length	Uncoated		AlTiN Coated	
								Tool #	Price	Tool #	Price
W $^{+.002"}_{-.000"}$	P $^{+.015"}_{-.000"}$		L2	L4	F	D2 (h6)	L1				
.015	.025	.197	.500	.590	.0938	.1875	1.5	QFG-187-015-025	33.70	QFG-187-015-025X	37.15
.015	.025	.260	.750	.853	.1250	.2500	2.0	QFG-250-015-025	33.70	QFG-250-015-025X	39.35
.017	.025	.197	.500	.590	.0938	.1875	1.5	QFG-187-017-025	33.70	QFG-187-017-025X	37.15
.017	.025	.260	.750	.853	.1250	.2500	2.0	QFG-250-017-025	33.70	QFG-250-017-025X	39.35
.020	.025	.197	.500	.590	.0938	.1875	1.5	QFG-187-020-025	33.70	QFG-187-020-025X	37.15
.020	.025	.260	.750	.853	.1250	.2500	2.0	QFG-250-020-025	33.70	QFG-250-020-025X	39.35
.020	.050	.190	.155	.590	.0860	.1875	1.5	QFG-180-020	33.70	QFG-180-020X	37.15
.020	.050	.197	.500	.590	.0938	.1875	1.5	QFG-187-020-050	33.70	QFG-187-020-050X	37.15
.020	.050	.240	.190	.853	.1050	.2500	2.0	QFG-230-020	33.70	QFG-230-020X	39.35
.020	.050	.260	0.19	.853	.1250	.2500	2.0	QFG-250-020	33.70	QFG-250-020X	39.35
.025	.025	.197	.500	.590	.0938	.1875	1.5	QFG-187-025-025	33.70	QFG-187-025-025X	37.15
.025	.025	.260	.750	.853	.1250	.2500	2.0	QFG-250-025-025	33.70	QFG-250-025-025X	39.35
.025	.050	.197	.500	.590	.0938	.1875	1.5	QFG-187-025-050	33.70	QFG-187-025-050X	37.15
.025	.050	.260	.750	.853	.1250	.2500	2.0	QFG-250-025-050	33.70	QFG-250-025-050X	39.35
.030	.050	.190	.155	.590	.0860	.1875	1.5	QFG-180-030	33.70	QFG-180-030X	37.15
.030	.050	.197	.500	.590	.0938	.1875	1.5	QFG-187-030-050	33.70	QFG-187-030-050X	37.15
.030	.050	.240	.190	.853	.1050	.2500	2.0	QFG-230-030	33.70	QFG-230-030X	39.35
.030	.050	.260	.190	.853	.1250	.2500	2.0	QFG-250-030	33.70	QFG-250-030X	39.35
.030	.050	.322	.225	.853	.1563	.3125	2.0	QFG-312-030	46.05	QFG-312-030X	52.60
.030	.050	.385	.750	.853	.1875	.3750	2.0	QFG-375-030-050	64.10	QFG-375-030-050X	71.35
.030	.075	.197	.500	.590	.0938	.1875	1.5	QFG-187-030-075	33.70	QFG-187-030-075X	37.15
.030	.075	.260	.750	.853	.1250	.2500	2.0	QFG-250-030-075	33.70	QFG-250-030-075X	39.35
.039	.050	.260	.750	.853	.1250	.2500	2.0	QFG-250-039-050	33.70	QFG-250-039-050X	39.35
.039	.050	.385	.750	.853	.1875	.3750	2.0	QFG-375-039-050	64.10	QFG-375-039-050X	71.35
.039	.075	.260	.750	.853	.1250	.2500	2.0	QFG-250-039-075	33.70	QFG-250-039-075X	39.35
.040	.050	.197	.500	.590	.0938	.1875	1.5	QFG-187-040-050	33.70	QFG-187-040-050X	37.15
.040	.050	.260	.750	.853	.1250	.2500	2.0	QFG-250-040-050	33.70	QFG-250-040-050X	39.35
.040	.050	.322	.225	.853	.1563	.3125	2.0	QFG-312-040	46.05	QFG-312-040X	52.60
.040	.050	.385	.750	.853	.1875	.3750	2.0	QFG-375-040-050	64.10	QFG-375-040-050X	71.35
.040	.075	.197	.500	.590	.0938	.1875	1.5	QFG-187-040-075	33.70	QFG-187-040-075X	37.15
.040	.075	.260	.750	.853	.1250	.2500	2.0	QFG-250-040-075	33.70	QFG-250-040-075X	39.35

*Minimum Groove Diameter provides proper clearance on outside of tooth during initial plunge.

Continued on next page

See pg 14-28 for quick change holder options

QFG

Quick Change – Grooving Tools

Face Grooving – Square (cont.)

Continued from previous page

Width	Projection	Minimum Groove Diameter*	Maximum Bore Depth	Length From Holder	Centerline Offset	Shank Diameter	Overall Length	Uncoated		AITIN Coated	
								Tool #	Price	Tool #	Price
W $+0.002''$ $-0.000''$	P $+0.015''$ $-0.000''$		L2	L4	F	D2 (h6)	L1				
.050	.050	.197	.500	.590	.0938	.1875	1.5	QFG-187-050-050	33.70	QFG-187-050-050X	37.15
.050	.050	.260	.750	.853	.1250	.2500	2.0	QFG-250-050-050	33.70	QFG-250-050-050X	39.35
.050	.050	.385	.750	.853	.1875	.3750	2.0	QFG-375-050-050	64.10	QFG-375-050-050X	71.35
.050	.075	.197	.500	.590	.0938	.1875	1.5	QFG-187-050-075	33.70	QFG-187-050-075X	37.15
.050	.075	.260	.750	.853	.1250	.2500	2.0	QFG-250-050-075	33.70	QFG-250-050-075X	39.35
.050	.075	.322	.750	.853	.1563	.3125	2.0	QFG-312-050-075	46.05	QFG-312-050-075X	52.60
.059	.075	.197	.500	.590	.0938	.1875	1.5	QFG-187-059-075	33.70	QFG-187-059-075X	37.15
.059	.075	.260	.750	.853	.1250	.2500	2.0	QFG-250-059-075	33.70	QFG-250-059-075X	39.35
.059	.075	.385	.750	.853	.1875	.3750	2.0	QFG-375-059-075	64.10	QFG-375-059-075X	71.35
.059	.100	.197	.500	.590	.0938	.1875	1.5	QFG-187-059-100	33.70	QFG-187-059-100X	37.15
.059	.100	.260	.750	.853	.1250	.2500	2.0	QFG-250-059-100	33.70	QFG-250-059-100X	39.35
.062	.075	.197	.500	.590	.0938	.1875	1.5	QFG-187-062-075	33.70	QFG-187-062-075X	37.15
.062	.075	.260	.750	.853	.1250	.2500	2.0	QFG-250-062-075	33.70	QFG-250-062-075X	39.35
.062	.075	.322	.750	.853	.1563	.3125	2.0	QFG-312-062-075	46.05	QFG-312-062-075X	52.60
.062	.075	.385	.750	.853	.1875	.3750	2.0	QFG-375-062-075	64.10	QFG-375-062-075X	71.35
.062	.100	.197	.500	.590	.0938	.1875	1.5	QFG-187-062-100	33.70	QFG-187-062-100X	37.15
.062	.100	.260	.750	.853	.1250	.2500	2.0	QFG-250-062-100	33.70	QFG-250-062-100X	39.35
.062	.100	.322	.225	.853	.1563	.3125	2.0	QFG-312-062	46.05	QFG-312-062X	52.60
.062	.100	.385	.260	.853	.1875	.3750	2.0	QFG-375-062	64.10	QFG-375-062X	71.35
.062	.100	.480	.335	1.040	.2200	.5000	2.5	QFG-470-062	72.60	QFG-470-062X	83.40
.062	.100	.500	.335	1.040	.2400	.5000	2.5	QFG-490-062	72.60	QFG-490-062X	83.40
.062	.150	.197	.500	.590	.0938	.1875	1.5	QFG-187-062-150	33.70	QFG-187-062-150X	37.15
.062	.150	.260	.750	.853	.1250	.2500	2.0	QFG-250-062-150	33.70	QFG-250-062-150X	39.35
.062	.150	.322	.750	.853	.1563	.3125	2.0	QFG-312-062-150	46.05	QFG-312-062-150X	52.60
.062	.150	.385	.750	.853	.1875	.3750	2.0	QFG-375-062-150	64.10	QFG-375-062-150X	71.35
.078	.100	.260	.750	.853	.1250	.2500	2.0	QFG-250-078-100	33.70	QFG-250-078-100X	39.35
.078	.100	.322	.750	.853	.1563	.3125	2.0	QFG-312-078-100	46.05	QFG-312-078-100X	52.60
.078	.100	.385	.260	.853	.1875	.3750	2.0	QFG-375-078	64.10	QFG-375-078X	71.35
.078	.100	.480	.335	1.040	.2200	.5000	2.5	QFG-470-078	72.60	QFG-470-078X	83.40
.078	.100	.500	.335	1.040	.2400	.5000	2.5	QFG-490-078	72.60	QFG-490-078X	83.40
.093	.100	.385	.260	.853	.1875	.3750	2.0	QFG-375-093	64.10	QFG-375-093X	71.35
.093	.100	.480	.335	1.040	.2200	.5000	2.5	QFG-470-093	72.60	QFG-470-093X	83.40
.093	.100	.500	.335	1.040	.2400	.5000	2.5	QFG-490-093	72.60	QFG-490-093X	83.40
.093	.150	.322	.750	.853	.1563	.3125	2.0	QFG-312-093-150	46.05	QFG-312-093-150X	52.60
.093	.150	.385	.750	.853	.1875	.3750	2.0	QFG-375-093-150	64.10	QFG-375-093-150X	71.35
.118	.150	.385	.260	.853	.1875	.3750	2.0	QFG-375-118	64.10	QFG-375-118X	71.35
.118	.150	.480	.335	1.040	.2200	.5000	2.5	QFG-470-118	72.60	QFG-470-118X	83.40
.118	.150	.500	.335	1.040	.2400	.5000	2.5	QFG-490-118	72.60	QFG-490-118X	83.40
.125	.150	.385	.260	.853	.1875	.3750	2.0	QFG-375-125	64.10	QFG-375-125X	71.35
.125	.150	.480	.335	1.040	.2200	.5000	2.5	QFG-470-125	72.60	QFG-470-125X	83.40
.125	.150	.500	.335	1.040	.2400	.5000	2.5	QFG-490-125	72.60	QFG-490-125X	83.40
.125	.250	.385	.750	.853	.1875	.3750	2.0	QFG-375-125-250	64.10	QFG-375-125-250X	71.35
.156	.150	.480	.335	1.040	.2200	.5000	2.5	QFG-470-156	72.60	QFG-470-156X	83.40
.156	.150	.500	.335	1.040	.2400	.5000	2.5	QFG-490-156	72.60	QFG-490-156X	83.40

*Minimum Groove Diameter provides proper clearance on outside of tooth during initial plunge.

See pg 14-28 for quick change holder options

Quick Change – Grooving Tools

Quick Change – Grooving Tools

Face Grooving – Corner Radius

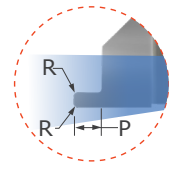
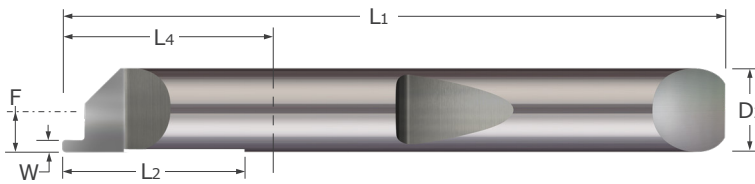

Quick Change – Grooving Tools

- Designed for generating corner radius grooves within the face of the part
- Polished split face for improved edge retention and chip evacuation while reducing galling
- Split face geometry provides optimal edge strength
- Relief ground along Maximum Bore Depth (L₂) to avoid interference during deep hole applications
- Coolant fed enabled shank design
- Corner radius profile
- Proprietary Micro-Quick change system maximizes productivity through reliable accuracy and locational repeatability
- AlTiN coated option provides added lubricity and increased wear resistance in difficult to machine materials
- Solid carbide ■ CNC ground in the USA

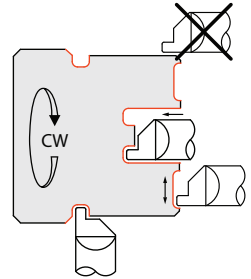

Width	Projection	Minimum Groove Diameter*	Radius	Maximum Bore Depth	Length From Holder	Centerline Offset	Shank Diameter	Overall Length	Uncoated		AlTiN Coated	
									Tool #	Price	Tool #	Price
W $+0.002"$ $-0.000"$	P $+0.015"$ $-0.000"$		R $+0.001"$ $-0.001"$	L ₂	L ₄	F	D ₂ (h6)	L ₁	Tool #	Price	Tool #	Price
.015	.025	.197	.003	.500	.590	.0938	.1875	1.5	QFGC3-187-015-025	31.05	QFGC3-187-015-025X	35.50
.015	.025	.260	.003	.750	.853	.1250	.2500	2.0	QFGC3-250-015-025	36.25	QFGC3-250-015-025X	41.90
.017	.025	.197	.003	.500	.590	.0938	.1875	1.5	QFGC3-187-017-025	31.05	QFGC3-187-017-025X	35.50
.017	.025	.260	.003	.750	.853	.1250	.2500	2.0	QFGC3-250-017-025	36.25	QFGC3-250-017-025X	41.90
.020	.025	.197	.003	.500	.590	.0938	.1875	1.5	QFGC3-187-020-025	31.05	QFGC3-187-020-025X	35.50
.020	.025	.260	.003	.750	.853	.1250	.2500	2.0	QFGC3-250-020-025	36.25	QFGC3-250-020-025X	41.90
.025	.025	.197	.003	.500	.590	.0938	.1875	1.5	QFGC3-187-025-025	31.05	QFGC3-187-025-025X	35.50
.025	.025	.260	.003	.750	.853	.1250	.2500	2.0	QFGC3-250-025-025	36.25	QFGC3-250-025-025X	41.90
.030	.050	.197	.003	.500	.590	.0938	.1875	1.5	QFGC3-187-030-050	31.05	QFGC3-187-030-050X	35.50
.030	.050	.260	.003	.750	.853	.1250	.2500	2.0	QFGC3-250-030-050	36.25	QFGC3-250-030-050X	41.90
.030	.050	.322	.003	.750	.853	.1563	.3125	2.0	QFGC3-312-030-050	47.60	QFGC3-312-030-050X	54.45
.030	.050	.385	.003	.750	.853	.1875	.3750	2.0	QFGC3-375-030-050	64.70	QFGC3-375-030-050X	72.80
.039	.050	.197	.003	.500	.590	.0938	.1875	1.5	QFGC3-187-039-050	31.05	QFGC3-187-039-050X	35.50
.039	.050	.260	.003	.750	.853	.1250	.2500	2.0	QFGC3-250-039-050	36.25	QFGC3-250-039-050X	41.90
.039	.050	.385	.003	.750	.853	.1875	.3750	2.0	QFGC3-375-039-050	64.70	QFGC3-375-039-050X	72.80
.040	.050	.197	.003	.500	.590	.0938	.1875	1.5	QFGC3-187-040-050	31.05	QFGC3-187-040-050X	35.50
.040	.050	.260	.003	.750	.853	.1250	.2500	2.0	QFGC3-250-040-050	36.25	QFGC3-250-040-050X	41.90
.040	.050	.322	.003	.750	.853	.1563	.3125	2.0	QFGC3-312-040-050	47.60	QFGC3-312-040-050X	54.45
.040	.050	.385	.003	.750	.853	.1875	.3750	2.0	QFGC3-375-040-050	64.70	QFGC3-375-040-050X	72.80
.050	.050	.197	.003	.500	.590	.0938	.1875	1.5	QFGC3-187-050-050	31.05	QFGC3-187-050-050X	35.50
.050	.050	.260	.003	.750	.853	.1250	.2500	2.0	QFGC3-250-050-050	36.25	QFGC3-250-050-050X	41.90
.050	.050	.322	.003	.750	.853	.1563	.3125	2.0	QFGC3-312-050-050	47.60	QFGC3-312-050-050X	54.45
.050	.050	.385	.003	.750	.853	.1875	.3750	2.0	QFGC3-375-050-050	64.70	QFGC3-375-050-050X	72.80
.059	.075	.385	.003	.750	.853	.1875	.3750	2.0	QFGC3-375-059-075	64.70	QFGC3-375-059-075X	72.80

*Minimum Groove Diameter provides proper clearance on outside of tooth during initial plunge.

Continued on next page

See pg 14-28 for quick change holder options

QFGC

Quick Change – Grooving Tools
Face Grooving – Corner Radius (cont.)

Continued from previous page

W	Projection	Minimum Groove Diameter*	Radius	Maximum Bore Depth	Length From Holder	Centerline Offset	Shank Diameter	Overall Length	Uncoated		AlTiN Coated	
									Tool #	Price	Tool #	Price
$W \begin{smallmatrix} +.002" \\ -.000" \end{smallmatrix}$	$P \begin{smallmatrix} +.015" \\ -.000" \end{smallmatrix}$		$R \begin{smallmatrix} +.001" \\ -.001" \end{smallmatrix}$	L2	L4	F	D2 (h6)	L1				
.062	.075	.197	.003	.500	.590	.0938	.1875	1.5	QFGC3-187-062-075	31.05	QFGC3-187-062-075X	35.50
.062	.075	.260	.003	.750	.853	.1250	.2500	2.0	QFGC3-250-062-075	36.25	QFGC3-250-062-075X	41.90
.062	.075	.322	.003	.750	.853	.1563	.3125	2.0	QFGC3-312-062-075	47.60	QFGC3-312-062-075X	54.45
.062	.075	.385	.003	.750	.853	.1875	.3750	2.0	QFGC3-375-062-075	64.70	QFGC3-375-062-075X	72.80
.062	.100	.197	.003	.500	.590	.0938	.1875	1.5	QFGC3-187-062-100	31.05	QFGC3-187-062-100X	35.50
.062	.100	.260	.003	.750	.853	.1250	.2500	2.0	QFGC3-250-062-100	36.25	QFGC3-250-062-100X	41.90
.078	.100	.260	.003	.750	.853	.1250	.2500	2.0	QFGC3-250-078-100	36.25	QFGC3-250-078-100X	41.90
.078	.100	.322	.003	.750	.853	.1563	.3125	2.0	QFGC3-312-078-100	47.60	QFGC3-312-078-100X	54.45
.078	.100	.385	.003	.750	.853	.1875	.3750	2.0	QFGC3-375-078-100	64.70	QFGC3-375-078-100X	72.80
.093	.100	.385	.006	.750	.853	.1875	.3750	2.0	QFGC6-375-093-100	64.70	QFGC6-375-093-100X	72.80
.093	.150	.322	.006	.750	.853	.1563	.3125	2.0	QFGC6-312-093-150	47.60	QFGC6-312-093-150X	54.45
.118	.150	.385	.006	.750	.853	.1875	.3750	2.0	QFGC6-375-118-150	64.70	QFGC6-375-118-150X	72.80
.125	.100	.385	.006	.750	.853	.1875	.3750	2.0	QFGC6-375-125-100	64.70	QFGC6-375-125-100X	72.80

*Minimum Groove Diameter provides proper clearance on outside of tooth during initial plunge.

Quick Change – Grooving Tools

Quick Change – Grooving Tools

Face Grooving – Full Radius

QFGF

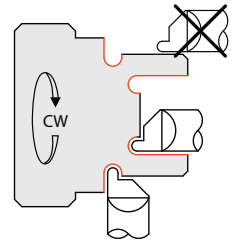
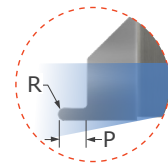
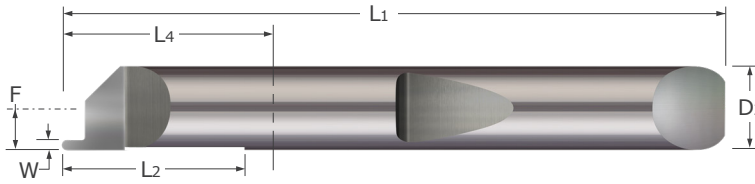

Quick Change – Grooving Tools

- Designed for generating full radius grooves in the face of the part
- Polished split face for improved edge retention and chip evacuation while reducing galling
- Split face geometry provides optimal edge strength
- Relief ground along Maximum Bore Depth (L2) to avoid interference during deep hole applications
- Coolant fed enabled shank design ■ Full radius profile
- Proprietary Micro-Quik quick change system maximizes productivity through reliable accuracy and locational repeatability
- AlTiN coated option provides added lubricity and increased wear resistance in difficult to machine materials
- Solid carbide ■ CNC ground in the USA

Width	Radius	Projection	Minimum Groove Diameter*	Maximum Bore Depth	Length From Holder	Centerline Offset	Shank Diameter	Overall Length	Uncoated		AlTiN Coated	
W	R	P		L2	L4	F	D2 (h6)	L1	Tool #	Price	Tool #	Price
.015	.0075	.025	.197	.500	.590	.0938	.1875	1.5	QFGF-187-015-025	31.25	QFGF-187-015-025X	35.70
.015	.0075	.025	.260	.750	.853	.1250	.2500	2.0	QFGF-250-015-025	34.95	QFGF-250-015-025X	40.60
.017	.0085	.025	.197	.500	.590	.0938	.1875	1.5	QFGF-187-017-025	31.25	QFGF-187-017-025X	35.70
.017	.0085	.025	.260	.750	.853	.1250	.2500	2.0	QFGF-250-017-025	34.95	QFGF-250-017-025X	40.60
.020	.0100	.050	.190	.155	.590	.0860	.1875	1.5	QFGF-180-020	31.25	QFGF-180-020X	35.70
.020	.0100	.050	.197	.500	.590	.0938	.1875	1.5	QFGF-187-020-050	31.25	QFGF-187-020-050X	35.70
.020	.0100	.050	.240	.190	.853	.1050	.2500	2.0	QFGF-230-020	34.95	QFGF-230-020X	40.60
.020	.0100	.050	.260	.190	.853	.1250	.2500	2.0	QFGF-250-020	34.95	QFGF-250-020X	40.60
.025	.0125	.050	.197	.500	.590	.0938	.1875	1.5	QFGF-187-025-050	31.25	QFGF-187-025-050X	35.70
.025	.0125	.050	.260	.750	.853	.1250	.2500	2.0	QFGF-250-025-050	34.95	QFGF-250-025-050X	40.60
.030	.0150	.050	.190	.155	.590	.0860	.1875	1.5	QFGF-180-030	31.25	QFGF-180-030X	35.70
.030	.0150	.050	.197	.500	.590	.0938	.1875	1.5	QFGF-187-030-050	31.25	QFGF-187-030-050X	35.70
.030	.0150	.050	.260	.190	.853	.1250	.2500	2.0	QFGF-250-030	34.95	QFGF-250-030X	40.60
.039	.0195	.075	.197	.500	.590	.0938	.1875	1.5	QFGF-187-039-075	31.25	QFGF-187-039-075X	35.70
.039	.0195	.075	.260	.750	.853	.1250	.2500	2.0	QFGF-250-039-075	34.95	QFGF-250-039-075X	40.60
.040	.0200	.050	.260	.190	.853	.1250	.2500	2.0	QFGF-250-040	34.95	QFGF-250-040X	40.60
.040	.0200	.075	.197	.500	.590	.0938	.1875	1.5	QFGF-187-040-075	31.25	QFGF-187-040-075X	35.70
.040	.0200	.075	.260	.750	.853	.1250	.2500	2.0	QFGF-250-040-075	34.95	QFGF-250-040-075X	40.60
.050	.0250	.050	.322	.225	.853	.1563	.3125	2.0	QFGF-312-050	47.65	QFGF-312-050X	54.50
.050	.0250	.075	.197	.500	.590	.0938	.1875	1.5	QFGF-187-050-075	31.25	QFGF-187-050-075X	35.70
.050	.0250	.075	.260	.750	.853	.1250	.2500	2.0	QFGF-250-050-075	34.95	QFGF-250-050-075X	40.60
.062	.0310	.075	.322	.750	.853	.1563	.3125	2.0	QFGF-312-062-075	47.65	QFGF-312-062-075X	54.50
.062	.0310	.075	.385	.750	.853	.1875	.3750	2.0	QFGF-375-062-075	66.00	QFGF-375-062-075X	74.10
.062	.0310	.100	.197	.500	.590	.0938	.1875	1.5	QFGF-187-062-100	31.25	QFGF-187-062-100X	35.70
.062	.0310	.100	.260	.750	.853	.1250	.2500	2.0	QFGF-250-062-100	34.95	QFGF-250-062-100X	40.60
.062	.0310	.100	.322	.225	.853	.1563	.3125	2.0	QFGF-312-062	47.65	QFGF-312-062X	54.50
.062	.0310	.100	.385	.260	.853	.1875	.3750	2.0	QFGF-375-062	66.00	QFGF-375-062X	74.10
.078	.0390	.100	.385	.260	.853	.1875	.3750	2.0	QFGF-375-078	66.00	QFGF-375-078X	74.10
.093	.0465	.100	.385	.260	.853	.1875	.3750	2.0	QFGF-375-093	66.00	QFGF-375-093X	74.10
.125	.0625	.150	.385	.260	.853	.1875	.3750	2.0	QFGF-375-125	66.00	QFGF-375-125X	74.10

*Minimum Groove Diameter provides proper clearance on outside of tooth during initial plunge.

See pg 14-28 for quick change holder options

QFGI

Quick Change – Grooving Tools
Face Grooving – Internal Tooth – Square

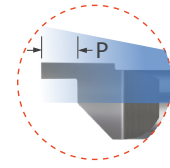
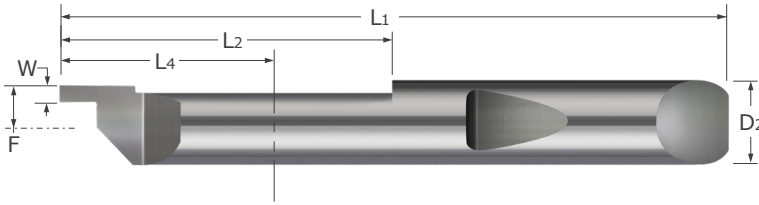

- Designed to generate square grooves around a boss in the face of a part for right hand grooving applications (M03) (See Graphic)
- Significantly reduces cycle times, as right hand design allows for multiple tools to be run simultaneously
- Relief ground along Maximum Turn Depth (L2) to avoid interference during long turning applications
- Polished split face for improved edge retention and chip evacuation while reducing galling
- Split face geometry provides optimal edge strength
- Coolant fed enabled shank design ■ Sharp corner profile
- Proprietary Micro-Quik quick change system maximizes productivity through reliable accuracy and locational repeatability
- AlTiN coated option provides added lubricity and increased wear resistance in difficult to machine materials
- Solid carbide ■ CNC ground in the USA

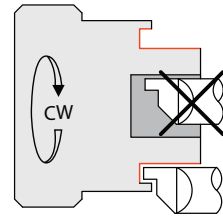

Quick Change – Grooving Tools

	Width	Projection	Minimum Groove Diameter*	Maximum Turn Depth	Length From Holder	Centerline Offset	Shank Diameter	Overall Length	Uncoated		AlTiN Coated	
	W $+0.002''$ $-0.000''$	P $+0.015''$ $-0.000''$		L2	L4	F	D2 (h6)	L1	Tool #	Price	Tool #	Price
NEW	.020	.040	.260	.750	.853	.1150	.2500	2.0	QFGI-8240	34.70	QFGI-8240X	40.35
NEW	.020	.040	.260	1.250	1.353	.1150	.2500	2.5	QFGI-6198	36.00	QFGI-6198X	42.05
NEW	.020	.040	.322	.750	.853	.1463	.3125	2.0	QFGI-9800	47.50	QFGI-9800X	54.35
NEW	.020	.040	.322	1.250	1.353	.1463	.3125	2.5	QFGI-6738	48.70	QFGI-6738X	55.95
NEW	.030	.060	.260	.750	.853	.1150	.2500	2.0	QFGI-6600	34.70	QFGI-6600X	40.35
NEW	.030	.060	.260	1.250	1.353	.1150	.2500	2.5	QFGI-3461	36.00	QFGI-3461X	42.05
NEW	.030	.060	.322	.750	.853	.1463	.3125	2.0	QFGI-5774	47.50	QFGI-5774X	54.35
NEW	.030	.060	.322	1.250	1.353	.1463	.3125	2.5	QFGI-1413	48.70	QFGI-1413X	55.95
NEW	.040	.080	.260	.750	.853	.1150	.2500	2.0	QFGI-6481	34.70	QFGI-6481X	40.35
NEW	.040	.080	.260	1.250	1.353	.1150	.2500	2.5	QFGI-9741	36.00	QFGI-9741X	42.05
NEW	.040	.080	.322	.750	.853	.1463	.3125	2.0	QFGI-8157	47.50	QFGI-8157X	54.35
NEW	.040	.080	.322	1.250	1.353	.1463	.3125	2.5	QFGI-9114	48.70	QFGI-9114X	55.95
NEW	.050	.100	.260	.750	.853	.1150	.2500	2.0	QFGI-1311	34.70	QFGI-1311X	40.35
NEW	.050	.100	.260	1.250	1.353	.1150	.2500	2.5	QFGI-7516	36.00	QFGI-7516X	42.05
NEW	.050	.100	.322	.750	.853	.1463	.3125	2.0	QFGI-5336	47.50	QFGI-5336X	54.35
NEW	.050	.100	.322	1.250	1.353	.1463	.3125	2.5	QFGI-9489	48.70	QFGI-9489X	55.95
NEW	.062	.125	.322	.750	.853	.1463	.3125	2.0	QFGI-2609	47.50	QFGI-2609X	54.35
NEW	.062	.125	.322	1.250	1.353	.1463	.3125	2.5	QFGI-0720	48.70	QFGI-0720X	55.95
NEW	.062	.125	.385	.750	.853	.1775	.3750	2.0	QFGI-3852	66.05	QFGI-3852X	74.15
NEW	.062	.125	.385	1.250	1.353	.1775	.3750	2.5	QFGI-8466	67.35	QFGI-8466X	75.95
NEW	.078	.156	.322	.750	.853	.1463	.3125	2.0	QFGI-4397	47.50	QFGI-4397X	54.35
NEW	.078	.156	.322	1.250	1.353	.1463	.3125	2.5	QFGI-3465	48.70	QFGI-3465X	55.95
NEW	.078	.156	.385	.750	.853	.1775	.3750	2.0	QFGI-2855	66.05	QFGI-2855X	74.15
NEW	.078	.156	.385	1.250	1.353	.1775	.3750	2.5	QFGI-2684	67.35	QFGI-2684X	75.95

*Minimum Groove Diameter provides proper clearance on outside of tooth during initial plunge.

Continued on next page

See pg 14-28 for quick change holder options



Quick Change – Grooving Tools

Face Grooving – Internal Tooth – Square (cont.)

QFGI

Continued from previous page

Width	Projection	Minimum Groove Diameter*	Maximum Turn Depth	Length From Holder	Centerline Offset	Shank Diameter	Overall Length	Uncoated		AITIN Coated	
								Tool #	Price	Tool #	Price
W $\begin{smallmatrix} +.002" \\ -.000" \end{smallmatrix}$	P $\begin{smallmatrix} +.015" \\ -.000" \end{smallmatrix}$		L2	L4	F	D ₂ (h6)	L1				
.093	.187	.322	.750	.853	.1463	.3125	2.0	QFGI-5482	47.50	QFGI-5482X	54.35
.093	.187	.322	1.250	1.353	.1463	.3125	2.5	QFGI-2378	48.70	QFGI-2378X	55.95
.093	.187	.385	.750	.853	.1775	.3750	2.0	QFGI-1641	66.05	QFGI-1641X	74.15
.093	.187	.385	1.250	1.353	.1775	.3750	2.5	QFGI-1707	67.35	QFGI-1707X	75.95
.118	.236	.385	.750	.853	.1775	.3750	2.0	QFGI-4674	66.05	QFGI-4674X	74.15
.118	.236	.385	1.250	1.353	.1775	.3750	2.5	QFGI-2969	67.35	QFGI-2969X	75.95
.118	.236	.510	1.000	1.040	.2400	.5000	2.5	QFGI-6754	74.80	QFGI-6754X	86.50
.118	.236	.510	1.500	1.540	.2400	.5000	3.0	QFGI-3667	76.10	QFGI-3667X	87.80
.125	.250	.385	.750	.853	.1775	.3750	2.0	QFGI-1535	66.05	QFGI-1535X	74.15
.125	.250	.385	1.250	1.353	.1775	.3750	2.5	QFGI-7015	67.35	QFGI-7015X	75.95
.125	.250	.510	1.000	1.040	.2400	.5000	2.5	QFGI-4349	74.80	QFGI-4349X	86.50
.125	.250	.510	1.500	1.540	.2400	.5000	3.0	QFGI-4098	76.10	QFGI-4098X	87.80

*Minimum Groove Diameter provides proper clearance on outside of tooth during initial plunge.



Check Real-Time Availability of Up to 50 Tools at Once

On Micro100.com/check-stock

QFGIC

Quick Change – Grooving Tools
Face Grooving – Internal Tooth - Corner Radius

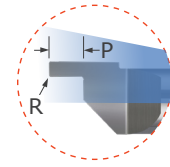
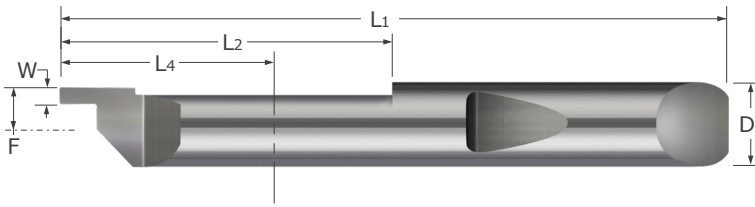

- Designed to generate corner radius grooves around a boss in the face of a part for right hand grooving applications (M03) (See Graphic)
- Significantly reduces cycle times, as right hand design allows for multiple tools to be run simultaneously
- Relief ground along Maximum Turn Depth (L2) to avoid interference during long turning applications
- Polished split face for improved edge retention and chip evacuation while reducing galling
- Split face geometry provides optimal edge strength
- Coolant fed enabled shank design ■ Corner radius profile
- Proprietary Micro-Quik quick change system maximizes productivity through reliable accuracy and locational repeatability
- AlTiN coated option provides added lubricity and increased wear resistance in difficult to machine materials
- Solid carbide ■ CNC ground in the USA

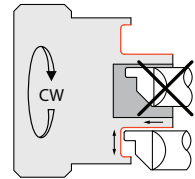

Quick Change – Grooving Tools

	Width		Radius		Projection		Minimum Groove Diameter*	Maximum Turn Depth	Length From Holder	Centerline Offset	Shank Diameter	Overall Length	Uncoated		AlTiN Coated	
	W	+ .002" / - .000"	R	+ .001" / - .001"	P	+ .015" / - .000"	L2	L4	F	D2 (h6)	L1	Tool #	Price	Tool #	Price	
NEW	.020	.003	.040	.260	1.250	1.353	.1150	.2500	2.5	QFGIC3-6198	36.70	QFGIC3-6198X	42.75			
NEW	.020	.003	.040	.322	1.250	1.353	.1463	.3125	2.5	QFGIC3-6738	49.65	QFGIC3-6738X	56.90			
NEW	.030	.003	.060	.260	1.250	1.353	.1150	.2500	2.5	QFGIC3-3461	36.70	QFGIC3-3461X	42.75			
NEW	.030	.003	.060	.322	1.250	1.353	.1463	.3125	2.5	QFGIC3-1413	49.65	QFGIC3-1413X	56.90			
NEW	.040	.003	.080	.260	1.250	1.353	.1150	.2500	2.5	QFGIC3-9741	36.70	QFGIC3-9741X	42.75			
NEW	.040	.003	.080	.322	1.250	1.353	.1463	.3125	2.5	QFGIC3-9114	49.65	QFGIC3-9114X	56.90			
NEW	.050	.003	.100	.260	1.250	1.353	.1150	.2500	2.5	QFGIC3-7516	36.70	QFGIC3-7516X	42.75			
NEW	.050	.003	.100	.322	1.250	1.353	.1463	.3125	2.5	QFGIC3-9489	49.65	QFGIC3-9489X	56.90			
NEW	.062	.003	.125	.322	1.250	1.353	.1463	.3125	2.5	QFGIC3-0720	49.65	QFGIC3-0720X	56.90			
NEW	.062	.003	.125	.385	1.250	1.353	.1775	.3750	2.5	QFGIC3-8466	68.65	QFGIC3-8466X	77.25			
NEW	.078	.003	.156	.322	1.250	1.353	.1463	.3125	2.5	QFGIC3-3465	49.65	QFGIC3-3465X	56.90			
NEW	.078	.003	.156	.385	1.250	1.353	.1775	.3750	2.5	QFGIC3-2684	68.65	QFGIC3-2684X	77.25			
NEW	.093	.006	.187	.322	1.250	1.353	.1463	.3125	2.5	QFGIC6-2378	49.65	QFGIC6-2378X	56.90			
NEW	.093	.006	.187	.385	1.250	1.353	.1775	.3750	2.5	QFGIC6-1707	68.65	QFGIC6-1707X	77.25			
NEW	.118	.006	.236	.385	1.250	1.353	.1775	.3750	2.5	QFGIC6-2969	68.65	QFGIC6-2969X	77.25			
NEW	.125	.006	.250	.385	1.250	1.353	.1775	.3750	2.5	QFGIC6-7015	68.65	QFGIC6-7015X	77.25			

*Minimum Groove Diameter provides proper clearance on outside of tooth during initial plunge.

See pg 14-28 for quick change holder options

Quick Change – Grooving Tools

Face Grooving – Internal Tooth - Full Radius

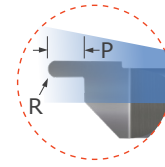
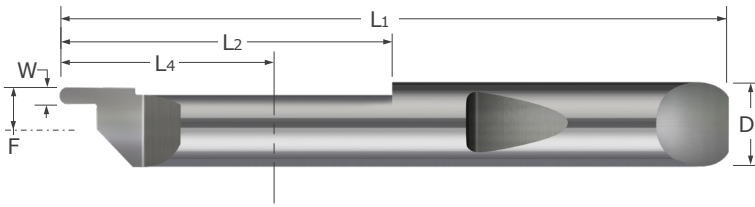

Quick Change – Grooving Tools

- Designed to generate corner radius grooves around a boss in the face of a part for right hand grooving applications (M03) (See Graphic)
- Significantly reduces cycle times, as right hand design allows for multiple tools to be run simultaneously
- Relief ground along Maximum Turn Depth (L2) to avoid interference during long turning applications
- Polished split face for improved edge retention and chip evacuation while reducing galling
- Split face geometry provides optimal edge strength
- Coolant fed enabled shank design
- Full radius profile
- Proprietary Micro-Quik quick change system maximizes productivity through reliable accuracy and locational repeatability
- AlTiN coated option provides added lubricity and increased wear resistance in difficult to machine materials
- Solid carbide
- CNC ground in the USA

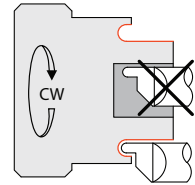

Width	Radius	Projection	Minimum Groove Diameter*	Maximum Turn Depth	Length From Holder	Centerline Offset	Shank Diameter	Overall Length	Uncoated		AlTiN Coated	
									Tool #	Price	Tool #	Price
W $\begin{matrix} +.002" \\ -.000" \end{matrix}$	R $\begin{matrix} +.0010" \\ -.0010" \end{matrix}$	P $\begin{matrix} +.015" \\ -.000" \end{matrix}$		L2	L4	F	D2 (h6)	L1				
.020	.0100	.040	.260	1.250	1.353	.1150	.2500	2.5	QFGIF-6198	37.40	QFGIF-6198X	43.45
.020	.0100	.040	.322	1.250	1.353	.1463	.3125	2.5	QFGIF-6738	50.65	QFGIF-6738X	57.90
.030	.0150	.060	.260	1.250	1.353	.1150	.2500	2.5	QFGIF-3461	37.40	QFGIF-3461X	43.45
.030	.0150	.060	.322	1.250	1.353	.1463	.3125	2.5	QFGIF-1413	50.65	QFGIF-1413X	57.90
.040	.0200	.080	.260	1.250	1.353	.1150	.2500	2.5	QFGIF-9741	37.40	QFGIF-9741X	43.45
.040	.0200	.080	.322	1.250	1.353	.1463	.3125	2.5	QFGIF-9114	50.65	QFGIF-9114X	57.90
.050	.0250	.100	.260	1.250	1.353	.1150	.2500	2.5	QFGIF-7516	37.40	QFGIF-7516X	43.45
.050	.0250	.100	.322	1.250	1.353	.1463	.3125	2.5	QFGIF-9489	50.65	QFGIF-9489X	57.90
.062	.0310	.125	.322	1.250	1.353	.1463	.3125	2.5	QFGIF-0720	50.65	QFGIF-0720X	57.90
.062	.0310	.125	.385	1.250	1.353	.1775	.3750	2.5	QFGIF-8466	69.95	QFGIF-8466X	78.55
.078	.0390	.156	.322	1.250	1.353	.1463	.3125	2.5	QFGIF-3465	50.65	QFGIF-3465X	57.90
.078	.0390	.156	.385	1.250	1.353	.1775	.3750	2.5	QFGIF-2684	69.95	QFGIF-2684X	78.55
.093	.0465	.187	.322	1.250	1.353	.1463	.3125	2.5	QFGIF-2378	50.65	QFGIF-2378X	57.90
.093	.0465	.187	.385	1.250	1.353	.1775	.3750	2.5	QFGIF-1707	69.95	QFGIF-1707X	78.55
.118	.0590	.236	.385	1.250	1.353	.1775	.3750	2.5	QFGIF-2969	69.95	QFGIF-2969X	78.55
.125	.0625	.250	.385	1.250	1.353	.1775	.3750	2.5	QFGIF-7015	69.95	QFGIF-7015X	78.55

*Minimum Groove Diameter provides proper clearance on outside of tooth during initial plunge.

See pg 14-28 for quick change holder options

QIT

Quick Change – Threading Tools
UN Threads – Single Point

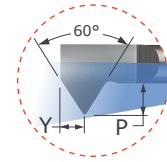
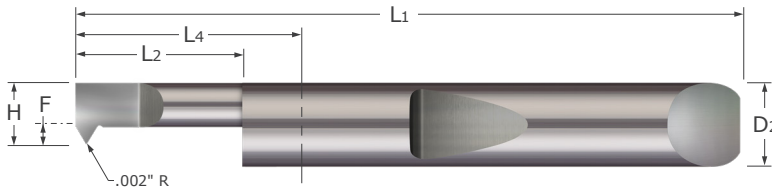

- Designed for threading in bores .040" and larger
- Able to cut multiple thread pitches (ANSI, UN, & Metric 60°) with one tool
- Polished split face for improved edge retention and chip evacuation while reducing galling
- Tools with a .050" and smaller Head Width have an on-center neck design
- .002" tip radius
- Coolant fed enabled shank design
- Proprietary Micro-Quik quick change system maximizes productivity through reliable accuracy and locational repeatability
- AlTiN coated option provides added lubricity and increased wear resistance in difficult to machine materials
- Solid carbide ■ CNC ground in the USA

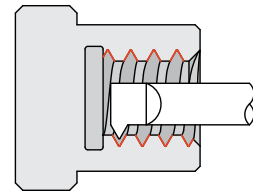

Quick Change – Threading Tools

Threads Per Inch	Head Width	Minimum Bore Diameter*	Maximum Bore Depth	Point Offset	Projection	Length From Holder	Centerline Offset	Shank Dia.	Overall Length	Uncoated		AlTiN Coated		
										Tool #	Price	Tool #	Price	
TPI*	H	L2	$L2 \begin{smallmatrix} +.030" \\ -.000" \end{smallmatrix}$	$Y \begin{smallmatrix} +.002" \\ -.000" \end{smallmatrix}$	P	L4	F	D2 (h6)	L1	Tool #	Price	Tool #	Price	
40-72	.0350	.0400	.075	.012	.015	.590	.0250	.1875	1.5	QIT-035075	49.05	QIT-035075X	53.10	
40-72	.0350	.0400	.100	.012	.015	.590	.0250	.1875	1.5	QIT-035100	49.05	QIT-035100X	53.10	
40-72	.0350	.0400	.150	.012	.015	.590	.0250	.1875	1.5	QIT-035150	49.05	QIT-035150X	53.10	
28-72	.0400	.0450	.075	.015	.020	.590	.0300	.1875	1.5	QIT-040075	49.05	QIT-040075X	53.10	
28-72	.0400	.0450	.150	.015	.020	.590	.0300	.1875	1.5	QIT-040150	49.05	QIT-040150X	53.10	
28-72	.0500	.0550	.100	.015	.020	.590	.0350	.1875	1.5			QIT-050100X	45.20	
28-72	.0500	.0550	.150	.015	.020	.590	.0350	.1875	1.5	QIT-050150	41.50	QIT-050150X	45.20	
28-72	.0500	.0550	.200	.015	.020	.590	.0350	.1875	1.5	QIT-050200	41.50	QIT-050200X	45.20	
NEW	28-56	.0600	.0700	.150	.015	.020	.590	-.0337	.1875	1.5	QIT-060150	41.50	QIT-060150X	46.25
	28-56	.0600	.0700	.200	.015	.020	.590	-.0335	.1875	1.5	QIT-060200	41.50	QIT-060200X	45.20
	28-56	.0600	.0700	.250	.015	.020	.590	-.0335	.1875	1.5	QIT-060250	41.50	QIT-060250X	45.20
	28-56	.0600	.0700	.300	.015	.020	.590	-.0335	.1875	1.5	QIT-060300	41.50	QIT-060300X	45.20
NEW	28-56	.0800	.0900	.200	.015	.020	.590	-.0137	.1875	1.5	QIT-080200	41.50	QIT-080200X	46.25
	28-56	.0800	.0900	.250	.015	.020	.590	-.0135	.1875	1.5	QIT-080250	41.50	QIT-080250X	45.20
	28-56	.0800	.0900	.350	.015	.020	.590	-.0135	.1875	1.5	QIT-080350	41.50	QIT-080350X	45.20
	28-56	.0800	.0900	.500	.015	.020	.590	-.0135	.1875	1.5	QIT-080500	41.50	QIT-080500X	45.20
	24-56	.1000	.1100	.250	.018	.025	.590	.0065	.1875	1.5	QIT-100250	41.50	QIT-100250X	45.20
	24-56	.1000	.1100	.350	.018	.025	.590	.0065	.1875	1.5	QIT-100350	41.50	QIT-100350X	45.20
	24-56	.1000	.1100	.500	.018	.025	.590	.0065	.1875	1.5	QIT-100500	41.50	QIT-100500X	45.20
	24-56	.1000	.1100	.600	.018	.025	1.090	.0065	.1875	2.0	QIT-100600	41.50	QIT-100600X	45.20
	20-56	.1100	.1260	.250	.020	.030	.590	.0165	.1875	1.5	QIT-110250	41.50	QIT-110250X	45.20
	20-56	.1100	.1260	.400	.020	.030	.590	.0165	.1875	1.5	QIT-110400	41.50	QIT-110400X	45.20
	20-56	.1100	.1260	.500	.020	.030	.590	.0165	.1875	1.5	QIT-110500	41.50	QIT-110500X	45.20
	20-56	.1100	.1260	.600	.020	.030	1.090	.0165	.1875	2.0	QIT-110600	41.50	QIT-110600X	45.20
	20-56	.1100	.1260	.750	.020	.030	1.090	.0165	.1875	2.0	QIT-110750	41.50	QIT-110750X	45.20

*Suggested Minimum Bore Diameter to accommodate chip evacuation and retract clearance in static (not live) applications.

Continued on next page

See pg 14-28 for quick change holder options

Quick Change – Threading Tools

QIT

UN Threads – Single Point (cont.)

Continued from previous page

Threads Per Inch	Head Width	Minimum Bore Diameter*	Maximum Bore Depth	Point Offset	Projection	Length From Holder	Centerline Offset	Shank Dia.	Overall Length	Uncoated		AITIN Coated	
										Tool #	Price	Tool #	Price
TPI*	H		L ₂ $\begin{matrix} +.030" \\ -.000" \end{matrix}$	Y $\begin{matrix} +.002" \\ -.000" \end{matrix}$	P	L ₄	F	D ₂ (h6)	L ₁				
20-56	.1200	.1360	.250	.020	.030	.590	.0265	.1875	1.5	QIT-120250	41.50	QIT-120250X	45.20
20-56	.1200	.1360	.400	.020	.030	.590	.0265	.1875	1.5	QIT-120400	41.50	QIT-120400X	45.20
20-56	.1200	.1360	.500	.020	.030	.590	.0265	.1875	1.5	QIT-120500	41.50	QIT-120500X	45.20
20-56	.1200	.1360	.600	.020	.030	1.090	.0265	.1875	2.0	QIT-120600	41.50	QIT-120600X	45.20
20-56	.1200	.1360	.750	.020	.030	1.090	.0265	.1875	2.0	QIT-120750	41.50	QIT-120750X	45.20
16-56	.1400	.1560	.250	.023	.035	.590	.0465	.1875	1.5	QIT-140250	41.50	QIT-140250X	45.20
16-56	.1400	.1560	.400	.023	.035	.590	.0465	.1875	1.5	QIT-140400	41.50	QIT-140400X	45.20
16-56	.1400	.1560	.500	.023	.035	.590	.0465	.1875	1.5	QIT-140500	41.50	QIT-140500X	45.20
16-56	.1400	.1560	.750	.023	.035	1.090	.0465	.1875	2.0	QIT-140750	41.50	QIT-140750X	45.20
16-56	.1400	.1560	1.000	.023	.035	1.090	.0462	.1875	2.0	QIT-1401000	41.50	QIT-1401000X	46.25
14-56	.1600	.1820	.250	.029	.040	.590	.0665	.1875	1.5	QIT-160250	41.50	QIT-160250X	45.20
14-56	.1600	.1820	.400	.029	.040	.590	.0665	.1875	1.5	QIT-160400	41.50	QIT-160400X	45.20
14-56	.1600	.1820	.500	.029	.040	.590	.0665	.1875	1.5	QIT-160500	41.50	QIT-160500X	45.20
14-56	.1600	.1820	.750	.029	.040	1.090	.0665	.1875	2.0	QIT-160750	41.50	QIT-160750X	45.20
14-56	.1600	.1820	1.000	.029	.040	1.090	.0665	.1875	2.0	QIT-1601000	41.50	QIT-1601000X	45.20
14-56	.1800	.2020	.350	.029	.040	.853	.0550	.2500	2.0	QIT-180350	44.30	QIT-180350X	49.95
14-56	.1800	.2020	.500	.029	.040	.853	.0550	.2500	2.0	QIT-180500	44.30	QIT-180500X	49.95
14-56	.1800	.2020	.750	.029	.040	.853	.0550	.2500	2.0	QIT-180750	44.30	QIT-180750X	49.95
14-56	.1800	.2020	1.000	.029	.040	1.353	.0550	.2500	2.5	QIT-1801000	44.30	QIT-1801000X	50.35
14-56	.1800	.2020	1.125	.029	.040	1.353	.0550	.2500	2.5	QIT-1801125	44.30	QIT-1801125X	50.35
13-56	.2000	.2220	.400	.032	.045	.853	.0750	.2500	2.0	QIT-200400	44.30	QIT-200400X	49.95
13-56	.2000	.2220	.600	.032	.045	.853	.0750	.2500	2.0	QIT-200600	44.30	QIT-200600X	49.95
13-56	.2000	.2220	.750	.032	.045	.853	.0750	.2500	2.0	QIT-200750	44.30	QIT-200750X	49.95
13-56	.2000	.2220	1.000	.032	.045	1.353	.0750	.2500	2.5	QIT-2001000	44.30	QIT-2001000X	50.35
13-56	.2000	.2220	1.125	.032	.045	1.353	.0750	.2500	2.5	QIT-2001125	44.30	QIT-2001125X	50.35
10-48	.2300	.2520	.400	.038	.055	.853	.0735	.3125	2.0	QIT-230400	55.45	QIT-230400X	62.30
10-48	.2300	.2520	.600	.038	.055	.853	.0735	.3125	2.0	QIT-230600	55.45	QIT-230600X	62.30
10-48	.2300	.2520	.750	.038	.055	.853	.0735	.3125	2.0	QIT-230750	55.45	QIT-230750X	62.30
10-48	.2300	.2520	1.000	.038	.055	1.353	.0735	.3125	2.5	QIT-2301000	55.45	QIT-2301000X	62.70
10-48	.2300	.2520	1.250	.038	.055	1.353	.0737	.3125	2.5	QIT-2301250	55.45	QIT-2301250X	62.70
10-48	.2300	.2520	1.500	.038	.055	1.853	.0735	.3125	3.0	QIT-2301500	62.75	QIT-2301500X	70.00
8-40	.2900	.3120	.500	.046	.070	.853	.1340	.3125	2.0	QIT-290500	55.45	QIT-290500X	62.30
8-40	.2900	.3120	.750	.046	.070	.853	.1340	.3125	2.0	QIT-290750	55.45	QIT-290750X	62.30
8-40	.2900	.3120	1.000	.046	.070	1.353	.1340	.3125	2.5	QIT-2901000	55.45	QIT-2901000X	62.35
8-40	.2900	.3120	1.250	.046	.070	1.353	.1340	.3125	2.5	QIT-2901250	55.45	QIT-2901250X	62.70
8-40	.2900	.3120	1.500	.046	.070	1.853	.1337	.3125	3.0	QIT-2901500	62.75	QIT-2901500X	70.00
8-40	.2900	.3120	1.750	.046	.070	1.853	.1340	.3125	3.0	QIT-2901750	62.75	QIT-2901750X	70.00
8-40	.3200	.3420	.500	.049	.075	.853	.1325	.3750	2.0	QIT-320500	72.20	QIT-320500X	79.70
8-40	.3200	.3420	.750	.049	.075	.853	.1325	.3750	2.0	QIT-320750	72.20	QIT-320750X	79.70
8-40	.3200	.3420	1.000	.049	.075	1.353	.1325	.3750	2.5	QIT-3201000	72.20	QIT-3201000X	80.80
8-40	.3200	.3420	1.250	.049	.075	1.353	.1325	.3750	2.5	QIT-3201250	72.20	QIT-3201250X	80.80
8-40	.3200	.3420	1.500	.049	.075	1.853	.1325	.3750	3.0	QIT-3201500	79.50	QIT-3201500X	88.10
8-40	.3200	.3420	1.800	.049	.075	1.853	.1325	.3750	3.0	QIT-3201800	79.50	QIT-3201800X	88.10

*Suggested Minimum Bore Diameter to accommodate chip evacuation and retract clearance in static (not live) applications.

Continued on next page

Quick Change – Threading Tools

See pg 14-28 for quick change holder options



QIT

Quick Change – Threading Tools

UN Threads – Single Point (cont.)

Continued from previous page

Threads Per Inch	Head Width	Minimum Bore Diameter*	Maximum Bore Depth	Point Offset	Projection	Length From Holder	Centerline Offset	Shank Dia.	Overall Length	Uncoated		AITIN Coated	
										Tool #	Price	Tool #	Price
TPI*	H		L2 ^{+0.030"} _{-.000"}	Y ^{+0.002"} _{-.000"}	P	L4	F	D2 (h6)	L1				
7-32	.3600	.3820	.500	.055	.085	.853	.1725	.3750	2.0	QIT-360500	72.20	QIT-360500X	79.70
7-32	.3600	.3820	.750	.055	.085	.853	.1725	.3750	2.0	QIT-360750	72.20	QIT-360750X	79.70
7-32	.3600	.3820	1.000	.055	.085	1.353	.1725	.3750	2.5	QIT-3601000	72.20	QIT-3601000X	80.80
7-32	.3600	.3820	1.250	.055	.085	1.353	.1725	.3750	2.5	QIT-3601250	72.20	QIT-3601250X	80.80
NEW	7-32	.3600	.3820	1.500	.055	.085	1.853	.1725	3.0	QIT-3601500	79.50	QIT-3601500X	88.10
	7-32	.3600	.3820	1.800	.055	.085	1.853	.1725	3.0	QIT-3601800	79.50	QIT-3601800X	88.10
	5-32	.4600	.4820	.750	.078	.120	1.040	.2100	2.5	QIT-460750	101.25	QIT-460750X	112.95
	5-32	.4600	.4820	1.500	.078	.120	1.540	.2100	3.0	QIT-4601500	101.25	QIT-4601500X	112.95
	5-32	.4600	.4820	2.000	.078	.120	2.040	.2100	3.5	QIT-4602000	110.45	QIT-4602000X	123.00
	5-32	.4900	.5120	.750	.078	.120	1.040	.2400	2.5	QIT-490750	101.25	QIT-490750X	112.95
NEW	5-32	.4900	.5120	1.125	.078	.120	1.540	.2400	3.0	QIT-4901125	101.25	QIT-4901125X	112.95
	5-32	.4900	.5120	1.500	.078	.120	1.540	.2400	3.0	QIT-4901500	101.25	QIT-4901500X	112.95
	5-32	.4900	.5120	2.000	.078	.120	2.040	.2400	3.5	QIT-4902000	110.45	QIT-4902000X	123.00

*Suggested Minimum Bore Diameter to accommodate chip evacuation and retract clearance in static (not live) applications.

Quick Change – Threading Tools

UN Threads – Single Point – Left Hand

QITL

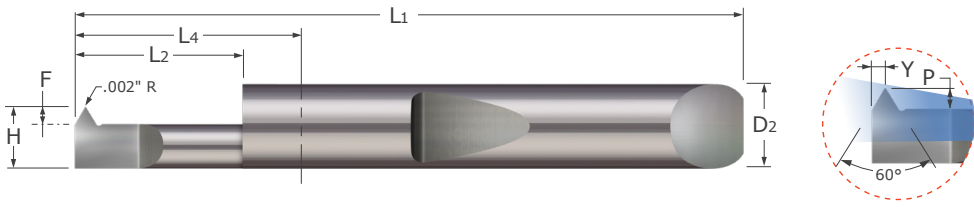

- Designed for threading multiple thread pitches (ANSI, UN, and Metric 60°) in a left hand threading application
- Polished split face for improved edge retention and chip evacuation while reducing galling
- Split face geometry provides optimal edge strength
- Coolant fed enabled shank design
- Corner radius profile
- Proprietary Micro-Quik quick change system maximizes productivity through reliable accuracy and locational repeatability
- AlTiN coated option provides added lubricity and increased wear resistance in difficult to machine materials
- Solid carbide
- CNC ground in the USA

Quick Change – Threading Tools

Threads Per Inch	Head Width	Minimum Bore Diameter*	Maximum Bore Depth	Point Offset	Projection	Length From Holder	Centerline Offset	Shank Dia.	Overall Length	Uncoated		AlTiN Coated	
										Tool #	Price	Tool #	Price
TPI*	H		L2 ^{+0.030"} / _{-.000"}	Y ^{+0.002"} / _{-.000"}	P	L4	F	D2 (h6)	L1				
20-56	.1200	.1360	.500	.017	.030	.590	.0262	.1875	1.5	QITL-120500	41.50	QITL-120500X	46.25
16-56	.1400	.1560	.500	.020	.035	.590	.0462	.1875	1.5	QITL-140500	41.50	QITL-140500X	46.25
14-56	.1600	.1820	.400	.023	.040	.590	.0662	.1875	1.5	QITL-160400	41.50	QITL-160400X	46.25
14-56	.1600	.1820	.750	.023	.040	1.090	.0662	.1875	2.0	QITL-160750	42.65	QITL-160750X	47.40
13-56	.2000	.2220	.600	.026	.045	.853	.0750	.2500	2.0	QITL-200600	44.30	QITL-200600X	49.95
13-56	.2000	.2220	1.000	.026	.045	1.353	.0750	.2500	2.5	QITL-2001000	45.45	QITL-2001000X	51.50
10-48	.2300	.2520	.750	.032	.055	.853	.0737	.3125	2.0	QITL-230750	55.45	QITL-230750X	62.30
10-48	.2300	.2520	1.000	.032	.055	1.353	.0737	.3125	2.5	QITL-2301000	56.60	QITL-2301000X	63.85
8-40	.2900	.3120	.750	.040	.070	.853	.1337	.3125	2.0	QITL-290750	55.45	QITL-290750X	62.30
8-40	.2900	.3120	1.250	.040	.070	1.353	.1337	.3125	2.5	QITL-2901250	56.60	QITL-2901250X	63.85
8-40	.3200	.3420	.750	.043	.075	.853	.1325	.3750	2.0	QITL-320750	72.20	QITL-320750X	80.30
8-40	.3200	.3420	1.000	.043	.075	1.353	.1325	.3750	2.5	QITL-3201000	73.30	QITL-3201000X	81.90
7-32	.3600	.3820	.750	.049	.085	.853	.1725	.3750	2.0	QITL-360750	72.20	QITL-360750X	80.30
7-32	.3600	.3820	1.250	.049	.085	1.353	.1725	.3750	2.5	QITL-3601250	73.30	QITL-3601250X	81.90
5-32	.4900	.5120	1.500	.069	.120	1.540	.2400	.5000	3.0	QITL-4901500	102.40	QITL-4901500X	114.10

*Suggested Minimum Bore Diameter to accommodate chip evacuation and retract clearance in static (not live) applications.

QTT

Quick Change – Threading Tools
UN Topping– Single Point

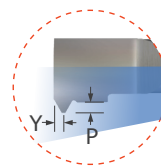
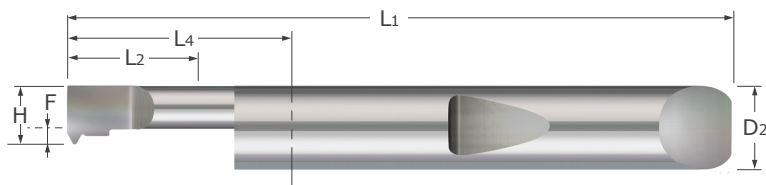

- Designed for threading 60° UN pitches in a right hand topping application
- Topping design generates a controlled thread height with a reduction in burr formation
- Polished split face for improved edge retention and chip evacuation while reducing galling
- Split face geometry provides optimal edge strength
- Coolant fed enabled shank design
- Proprietary Micro-Quik quick change system maximizes productivity through reliable accuracy and locational repeatability
- AlTiN coated option provides added lubricity and increased wear resistance in difficult to machine materials
- Solid carbide ■ CNC ground in the USA

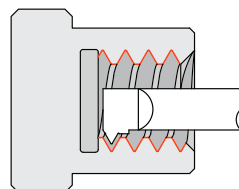

Quick Change – Threading Tools

	Thread Size	Head Width	Minimum Bore Diameter*	Maximum Bore Depth	Point Offset	Projection	Length From Holder	Centerline Offset	Shank Dia.	Overall Length	Uncoated		AlTiN Coated	
											Tool #	Price	Tool #	Price
		H		L2	Y	P	L4	F	D2 (h6)	L1				
				$\pm .030$ $-.000$	$\pm .005$ $-.000$	$\pm .0000$ $-.0020$								
NEW	2-56	.050	.055	.150	.012	.0097	.590	-.0438	.1875	1.5	QTT-000256-015	42.35	QTT-000256-015X	47.10
NEW	2-56	.050	.055	.200	.012	.0097	.590	-.0438	.1875	1.5	QTT-000256-020	42.35	QTT-000256-020X	47.10
NEW	4-40	.065	.075	.200	.014	.0135	.590	-.0288	.1875	1.5	QTT-000440-020	42.35	QTT-000440-020X	47.10
NEW	4-40	.065	.075	.250	.014	.0135	.590	-.0288	.1875	1.5	QTT-000440-025	42.35	QTT-000440-025X	47.10
NEW	5-44	.080	.090	.200	.014	.0123	.590	-.0138	.1875	1.5	QTT-000544-020	42.35	QTT-000544-020X	47.10
NEW	5-44	.080	.090	.250	.014	.0123	.590	-.0138	.1875	1.5	QTT-000544-025	42.35	QTT-000544-025X	47.10
NEW	6-32	.080	.090	.250	.017	.0169	.590	-.0138	.1875	1.5	QTT-000632-025	42.35	QTT-000632-025X	47.10
NEW	6-32	.080	.090	.350	.017	.0169	.590	-.0138	.1875	1.5	QTT-000632-035	42.35	QTT-000632-035X	47.10
NEW	8-32	.100	.110	.250	.017	.0169	.590	.0063	.1875	1.5	QTT-000832-025	42.35	QTT-000832-025X	47.10
NEW	8-32	.100	.110	.350	.017	.0169	.590	.0063	.1875	1.5	QTT-000832-035	42.35	QTT-000832-035X	47.10
NEW	10-24	.120	.136	.250	.021	.0226	.590	.0263	.1875	1.5	QTT-001024-025	42.35	QTT-001024-025X	47.10
NEW	10-24	.120	.136	.400	.021	.0226	.590	.0263	.1875	1.5	QTT-001024-040	42.35	QTT-001024-040X	47.10
NEW	10-32	.120	.136	.250	.017	.0169	.590	.0263	.1875	1.5	QTT-001032-025	42.35	QTT-001032-025X	47.10
NEW	10-32	.120	.136	.400	.017	.0169	.590	.0263	.1875	1.5	QTT-001032-040	42.35	QTT-001032-040X	47.10
NEW	1/4-20	.160	.182	.400	.024	.0271	.590	.0663	.1875	1.5	QTT-014020-040	42.35	QTT-014020-040X	47.10
NEW	1/4-20	.160	.182	.500	.024	.0271	.590	.0663	.1875	1.5	QTT-014020-050	42.35	QTT-014020-050X	47.10
NEW	1/4-28	.180	.202	.500	.018	.0193	.853	.0550	.2500	2.0	QTT-014028-050	45.25	QTT-014028-050X	50.90
NEW	1/4-28	.180	.202	.750	.018	.0193	.853	.0550	.2500	2.0	QTT-014028-075	45.25	QTT-014028-075X	50.90
NEW	5/16-18	.220	.242	.750	.026	.0301	.853	.0638	.3125	2.0	QTT-051618-075	56.60	QTT-051618-075X	63.45
NEW	5/16-18	.220	.242	1.000	.026	.0301	1.353	.0638	.3125	2.5	QTT-051618-100	57.70	QTT-051618-100X	64.95
NEW	5/16-24	.220	.242	.750	.021	.0226	.853	.0638	.3125	2.0	QTT-051624-075	56.60	QTT-051624-075X	63.45
NEW	5/16-24	.220	.242	1.000	.021	.0226	1.353	.0638	.3125	2.5	QTT-051624-100	57.70	QTT-051624-100X	64.95
NEW	3/8-16	.280	.302	.750	.028	.0338	.853	.1238	.3125	2.0	QTT-038016-075	56.60	QTT-038016-075X	63.45
NEW	3/8-16	.280	.302	1.000	.028	.0338	1.353	.1238	.3125	2.5	QTT-038016-100	57.70	QTT-038016-100X	64.95
NEW	3/8-24	.300	.322	.750	.021	.0226	.853	.1438	.3125	2.0	QTT-038024-075	56.60	QTT-038024-075X	63.45
NEW	3/8-24	.300	.322	1.000	.021	.0226	1.353	.1438	.3125	2.5	QTT-038024-100	57.70	QTT-038024-100X	64.95

*Suggested Minimum Bore Diameter to accommodate chip evacuation and retract clearance in static (not live) applications.

Continued on next page

Quick Change – Threading Tools

UN Topping– Single Point (cont.)

Continued from previous page

Thread Size	Head Width	Minimum Bore Diameter*	Maximum Bore Depth	Point Offset	Projection	Length From Holder	Centerline Offset	Shank Dia.	Overall Length	Uncoated		AITIN Coated		
										Tool #	Price	Tool #	Price	
	H	L2	$\begin{matrix} +.030" \\ -.000" \end{matrix}$	$\begin{matrix} +.005" \\ -.000" \end{matrix}$	$\begin{matrix} +.000" \\ -.002" \end{matrix}$	L4	F	D2 (h6)	L1					
7/16-14	.310	.332	.750	.032	.0387	.853	.1538	.3125	2.0	QTT-071614-075	56.60	QTT-071614-075X	63.45	NEW
7/16-14	.310	.332	1.000	.032	.0387	1.353	.1538	.3125	2.5	QTT-071614-100	57.70	QTT-071614-100X	64.95	NEW
7/16-20	.350	.372	1.000	.024	.0271	1.353	.1625	.3750	2.5	QTT-071620-100	73.65	QTT-071620-100X	82.25	NEW
7/16-20	.350	.372	1.250	.024	.0271	1.353	.1625	.3750	2.5	QTT-071620-125	73.65	QTT-071620-125X	82.25	NEW
1/2-13	.380	.402	1.000	.034	.0416	1.040	.1300	.5000	2.5	QTT-012013-100	103.25	QTT-012013-100X	114.95	NEW
1/2-13	.380	.402	1.250	.034	.0416	1.540	.1300	.5000	3.0	QTT-012013-125	104.40	QTT-012013-125X	116.10	NEW
1/2-20	.410	.432	1.000	.024	.0271	1.040	.1600	.5000	2.5	QTT-012020-100	103.25	QTT-012020-100X	114.95	NEW
1/2-20	.410	.432	1.250	.024	.0271	1.540	.1600	.5000	3.0	QTT-012020-125	104.40	QTT-012020-125X	116.10	NEW
9/16-12	.410	.432	1.000	.036	.0451	1.040	.1600	.5000	2.5	QTT-091612-100	103.25	QTT-091612-100X	114.95	NEW
9/16-12	.410	.432	1.250	.036	.0451	1.540	.1600	.5000	3.0	QTT-091612-125	104.40	QTT-091612-125X	116.10	NEW
9/16-18	.460	.482	1.000	.026	.0301	1.040	.2100	.5000	2.5	QTT-091618-100	103.25	QTT-091618-100X	114.95	NEW
9/16-18	.460	.482	1.250	.026	.0301	1.540	.2100	.5000	3.0	QTT-091618-125	104.40	QTT-091618-125X	116.10	NEW
5/8-11	.490	.512	1.000	.039	.0492	1.040	.2400	.5000	2.5	QTT-058011-100	103.25	QTT-058011-100X	114.95	NEW
5/8-11	.490	.512	1.250	.039	.0492	1.540	.2400	.5000	3.0	QTT-058011-125	104.40	QTT-058011-125X	116.10	NEW
3/4-16	.490	.512	1.000	.028	.0338	1.040	.2400	.5000	2.5	QTT-034016-100	103.25	QTT-034016-100X	114.95	NEW
3/4-16	.490	.512	1.250	.028	.0338	1.540	.2400	.5000	3.0	QTT-034016-125	104.40	QTT-034016-125X	116.10	NEW

*Suggested Minimum Bore Diameter to accommodate chip evacuation and retract clearance in static (not live) applications.

Quick Change – Threading Tools

Sent Directly to Your Inbox

Valuable information about Micro 100 products and technical resources directly to your inbox. Be the first to know of newly-released tools to gain an immediate leg-up on the competition!



QTMT

Quick Change – Threading Tools
Metric Topping– Single Point

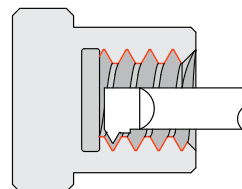
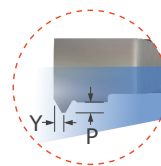
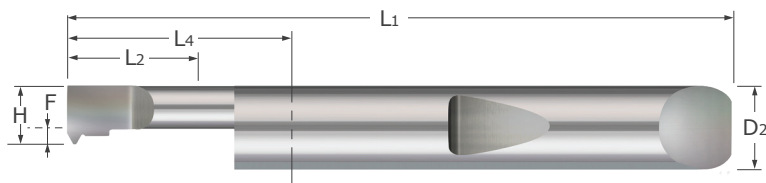

- Designed for threading 60° Metric pitches in a right hand topping application
- Topping design generates a controlled thread height with a reduction in burr formation
- Polished split face for improved edge retention and chip evacuation while reducing galling
- Split face geometry provides optimal edge strength
- Coolant fed enabled shank design
- Proprietary Micro-Quik quick change system maximizes productivity through reliable accuracy and locational repeatability
- AlTiN coated option provides added lubricity and increased wear resistance in difficult to machine materials
- Solid carbide ■ CNC ground in the USA

Quick Change – Threading Tools

	Thread Size	Head Width	Minimum Bore Diameter*	Maximum Bore Depth	Point Offset	Projection	Length From Holder	Centerline Offset	Shank Dia.	Overall Length	Uncoated		AlTiN Coated	
											Tool #	Price	Tool #	Price
		H		L2 +1.27mm -0.00mm	Y +0.127mm -0.000mm	P +0.000mm -0.051mm	L4	F	D2 (h6)	L1				
NEW	M2.5x0.45	1.50mm	1.70mm	5.00mm	.300mm	.244mm	14.99mm	-0.88mm	.1875	1.5	QTMT-025045-05	42.35	QTMT-025045-05X	46.55
NEW	M2.5x0.45	1.50mm	1.70mm	7.00mm	.300mm	.244mm	14.99mm	-0.88mm	.1875	1.5	QTMT-025045-07	42.35	QTMT-025045-07X	46.55
NEW	M3x0.50	2.00mm	2.20mm	6.00mm	.319mm	.271mm	14.99mm	-0.38mm	.1875	1.5	QTMT-030050-06	42.35	QTMT-030050-06X	46.55
NEW	M3x0.50	2.00mm	2.20mm	8.00mm	.319mm	.271mm	14.99mm	-0.38mm	.1875	1.5	QTMT-030050-08	42.35	QTMT-030050-08X	46.55
NEW	M4x0.70	2.50mm	2.70mm	7.00mm	.396mm	.379mm	14.99mm	0.12mm	.1875	1.5	QTMT-040070-07	42.35	QTMT-040070-07X	46.55
NEW	M4x0.70	2.50mm	2.70mm	10.00mm	.396mm	.379mm	14.99mm	0.12mm	.1875	1.5	QTMT-040070-10	42.35	QTMT-040070-10X	46.55
NEW	M4.5x0.75	3.00mm	3.40mm	6.00mm	.415mm	.406mm	14.99mm	0.62mm	.1875	1.5	QTMT-045075-06	42.35	QTMT-045075-06X	46.55
NEW	M4.5x0.75	3.00mm	3.40mm	9.00mm	.415mm	.406mm	14.99mm	0.62mm	.1875	1.5	QTMT-045075-09	42.35	QTMT-045075-09X	46.55
NEW	M5x0.80	3.00mm	3.40mm	6.00mm	.434mm	.433mm	14.99mm	0.62mm	.1875	1.5	QTMT-050080-06	42.35	QTMT-050080-06X	46.55
NEW	M5x0.80	3.00mm	3.40mm	9.00mm	.434mm	.433mm	14.99mm	0.62mm	.1875	1.5	QTMT-050080-09	42.35	QTMT-050080-09X	46.55
NEW	M6x1.00	4.00mm	4.50mm	10.00mm	.511mm	.541mm	14.99mm	1.62mm	.1875	1.5	QTMT-060100-10	42.35	QTMT-060100-10X	46.55
NEW	M6x1.00	4.00mm	4.50mm	14.00mm	.511mm	.541mm	27.69mm	1.62mm	.1875	2.0	QTMT-060100-14	43.45	QTMT-060100-14X	47.65
NEW	M8x1.25	5.50mm	6.00mm	14.00mm	.607mm	.677mm	21.67mm	1.53mm	.3125	2.0	QTMT-080125-14	56.60	QTMT-080125-14X	60.80
NEW	M8x1.25	5.50mm	6.00mm	22.00mm	.607mm	.677mm	34.37mm	1.53mm	.3125	2.5	QTMT-080125-22	57.70	QTMT-080125-22X	61.90
NEW	M10x1.50	7.50mm	8.00mm	24.00mm	.703mm	.812mm	34.37mm	3.53mm	.3125	2.5	QTMT-100150-24	57.70	QTMT-100150-24X	61.90
NEW	M10x1.50	7.50mm	8.00mm	31.00mm	.703mm	.812mm	34.37mm	3.53mm	.3125	2.5	QTMT-100150-31	57.70	QTMT-100150-31X	61.90
NEW	M12x1.75	9.00mm	9.50mm	22.00mm	.804mm	.957mm	34.37mm	4.24mm	.3750	2.5	QTMT-120175-22	73.65	QTMT-120175-22X	77.85
NEW	M12x1.75	9.00mm	9.50mm	31.00mm	.804mm	.957mm	34.37mm	4.24mm	.3750	2.5	QTMT-120175-31	73.65	QTMT-120175-31X	77.85
NEW	M16x2.00	12.50mm	13.00mm	31.00mm	.896mm	1.085mm	39.12mm	6.15mm	.5000	3.0	QTMT-160200-31	104.40	QTMT-160200-31X	108.60
NEW	M16x2.00	12.50mm	13.00mm	44.00mm	.896mm	1.085mm	51.82mm	6.15mm	.5000	3.5	QTMT-160200-44	107.65	QTMT-160200-44X	111.85
NEW	M20x2.50	12.50mm	13.00mm	31.00mm	1.086mm	1.353mm	39.12mm	6.15mm	.5000	3.0	QTMT-200250-31	104.40	QTMT-200250-31X	108.60
NEW	M20x2.50	12.50mm	13.00mm	44.00mm	1.086mm	1.353mm	51.82mm	6.15mm	.5000	3.5	QTMT-200250-44	107.65	QTMT-200250-44X	111.85

*Suggested Minimum Bore Diameter to accommodate chip evacuation and retract clearance in static (not live) applications.

Quick Change – Holemaking Tools

Spotting Drills

QSPD

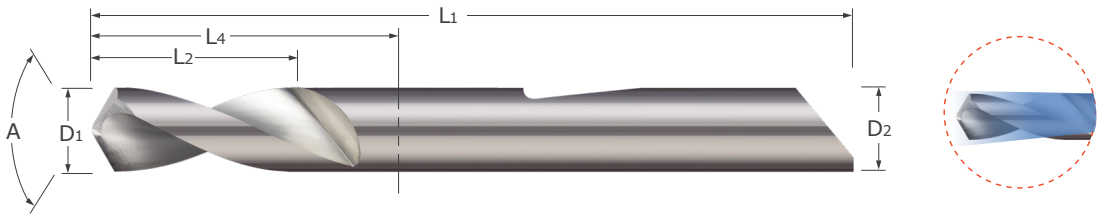

- Designed for spot drilling
- Available in 82°, 90°, 120°, and 140° included angles
- Can be utilized for countersinking and chamfering existing holes
- Narrow web thickness allows for spotting small diameter holes
- Point geometry designed for self centering
- Coolant fed enabled shank design
- Proprietary Micro-Quik quick change system maximizes productivity through reliable accuracy and locational repeatability
- AlTiN coated option provides added lubricity and increased wear resistance in difficult to machine materials
- Solid carbide ■ 2 flutes ■ CNC ground in the USA

Point Geometry Types

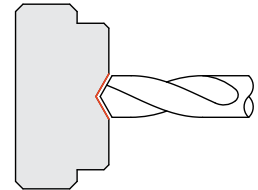
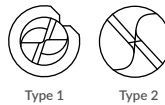

Quick Change – Holemaking Tools

Included Angle	Drill Diameter	Flute Length	Web Thickness	Type	Length From Holder	Shank Diameter	Overall Length	Uncoated		AlTiN Coated	
								Tool #	Price	Tool #	Price
82°	D1 $+0.0000$ / -0.0005 "	L2 $+0.010$ / -0.000 "	$+0.001$ / -0.001 "		L4	D2 (h6)	L1				
	.0900	.270	.006	I	.590	.1875	1.5	QSPD-090-082	30.45	QSPD-090-082X	35.20
	.1181	.354	.008	I	.590	.1875	1.5	QSPD-118-082	30.45	QSPD-118-082X	35.20
	.1250	.375	.010	I	.590	.1875	1.5	QSPD-125-082	30.45	QSPD-125-082X	35.20
	.1875	.625	.005	II	1.090	.1875	2.0	QSPD-187-082	30.45	QSPD-187-082X	35.20
	.2500	.750	.005	II	1.353	.2500	2.5	QSPD-250-082	35.90	QSPD-250-082X	41.95
	.3750	1.000	.005	II	1.353	.3750	2.5	QSPD-375-082	48.30	QSPD-375-082X	56.90
.5000	1.000	.005	II	1.540	.5000	3.0	QSPD-500-082	65.10	QSPD-500-082X	76.80	
90°	.0200	.060	.002	I	.590	.1875	1.5			QSPD-020-090X	41.40
	.0250	.075	.002	I	.590	.1875	1.5	QSPD-025-090	35.00		
	.0300	.090	.003	I	.590	.1875	1.5	QSPD-030-090	35.00		
	.0350	.105	.003	I	.590	.1875	1.5	QSPD-035-090	35.00	QSPD-035-090X	38.50
	.0400	.120	.004	I	.590	.1875	1.5	QSPD-040-090	30.45	QSPD-040-090X	33.75
	.0450	.135	.004	I	.590	.1875	1.5	QSPD-045-090	30.45	QSPD-045-090X	33.75
	.0600	.180	.006	I	.590	.1875	1.5	QSPD-060-090	30.45	QSPD-060-090X	33.75
	.0900	.270	.006	I	.590	.1875	1.5	QSPD-090-090	30.45	QSPD-090-090X	33.75
	.1181	.354	.008	I	.590	.1875	1.5	QSPD-118-090	30.45	QSPD-118-090X	33.75
	.1250	.375	.010	I	.590	.1875	1.5	QSPD-125-090	30.45	QSPD-125-090X	33.75
	.1875	.625	.005	II	1.090	.1875	2.0	QSPD-187-090	30.45	QSPD-187-090X	33.75
	.2500	.750	.005	II	1.353	.2500	2.5	QSPD-250-090	35.90	QSPD-250-090X	41.60
	.3750	1.000	.005	II	1.353	.3750	2.5	QSPD-375-090	48.30	QSPD-375-090X	56.70
.5000	1.000	.005	II	1.540	.5000	3.0	QSPD-500-090	65.10	QSPD-500-090X	76.80	
100°	.0900	.270	.006	I	.590	.1875	1.5	QSPD-090-100	30.45	QSPD-090-100X	35.20
	.1181	.354	.008	I	.590	.1875	1.5	QSPD-118-100	30.45	QSPD-118-100X	35.20
	.1250	.375	.010	I	.590	.1875	1.5	QSPD-125-100	30.45	QSPD-125-100X	35.20
	.1875	.625	.005	II	1.090	.1875	2.0	QSPD-187-100	30.45	QSPD-187-100X	35.20
	.2500	.750	.005	II	1.353	.2500	2.5	QSPD-250-100	35.90	QSPD-250-100X	41.95
	.3750	1.000	.005	II	1.353	.3750	2.5	QSPD-375-100	48.30	QSPD-375-100X	56.90
	.5000	1.000	.005	II	1.540	.5000	3.0	QSPD-500-100	65.10	QSPD-500-100X	76.80

Continued on next page

See pg 14-28 for quick change holder options

QSPD

Quick Change – Holmaking Tools
Spotting Drills (cont.)

Continued from previous page

Included Angle	Drill Diameter	Flute Length	Web Thickness	Type	Length From Holder	Shank Diameter	Overall Length	Uncoated		AlTiN Coated	
								Tool #	Price	Tool #	Price
A	D1 $+.0000"$ $-.0005"$	L2 $+.010"$ $-.000"$	$+.001"$ $-.001"$		L4	D2 (h6)	L1				
120°	.0150	.045	.002	I	.590	.1875	1.5	QSPD-015-120	39.35	QSPD-015-120X	43.05
	.0200	.060	.002	I	.590	.1875	1.5	QSPD-020-120	39.35	QSPD-020-120X	43.05
	.0250	.075	.002	I	.590	.1875	1.5	QSPD-025-120	35.00		
	.0300	.090	.003	I	.590	.1875	1.5	QSPD-030-120	35.00		
	.0350	.105	.003	I	.590	.1875	1.5	QSPD-035-120	35.00		
	.0400	.120	.004	I	.590	.1875	1.5	QSPD-040-120	30.45	QSPD-040-120X	33.75
	.0450	.135	.004	I	.590	.1875	1.5	QSPD-045-120	30.45	QSPD-045-120X	33.75
	.0600	.180	.006	I	.590	.1875	1.5	QSPD-060-120	30.45	QSPD-060-120X	33.75
	.0900	.270	.006	I	.590	.1875	1.5	QSPD-090-120	30.45	QSPD-090-120X	33.75
	.1181	.354	.008	I	.590	.1875	1.5	QSPD-118-120	30.45	QSPD-118-120X	33.75
	.1250	.375	.010	I	.590	.1875	1.5	QSPD-125-120	30.45	QSPD-125-120X	33.75
	.1875	.625	.005	II	1.090	.1875	2.0	QSPD-187-120	30.45	QSPD-187-120X	33.75
	.2500	.750	.005	II	1.353	.2500	2.5	QSPD-250-120	35.90	QSPD-250-120X	41.60
	.3750	1.000	.005	II	1.353	.3750	2.5	QSPD-375-120	48.30	QSPD-375-120X	56.70
.5000	1.000	.005	II	1.540	.5000	3.0	QSPD-500-120	65.10	QSPD-500-120X	76.80	
140°	.0150	.045	.002	I	.590	.1875	1.5			QSPD-015-140X	43.05
	.0200	.060	.002	I	.590	.1875	1.5			QSPD-020-140X	43.05
	.0250	.075	.002	I	.590	.1875	1.5	QSPD-025-140	35.00		
	.0300	.090	.003	I	.590	.1875	1.5	QSPD-030-140	35.00	QSPD-030-140X	38.50
	.0350	.105	.003	I	.590	.1875	1.5	QSPD-035-140	35.00		
	.0400	.120	.004	I	.590	.1875	1.5	QSPD-040-140	30.45		
	.0450	.135	.004	I	.590	.1875	1.5	QSPD-045-140	30.45	QSPD-045-140X	33.75
	.0500	.150	.005	I	.590	.1875	1.5	QSPD-050-140	30.45	QSPD-050-140X	33.75
	.0600	.180	.006	I	.590	.1875	1.5	QSPD-060-140	30.45	QSPD-060-140X	33.75
	.0900	.270	.006	I	.590	.1875	1.5	QSPD-090-140	30.45	QSPD-090-140X	33.75
	.1181	.354	.008	I	.590	.1875	1.5	QSPD-118-140	30.45	QSPD-118-140X	33.75
	.1250	.375	.010	I	.590	.1875	1.5	QSPD-125-140	30.45	QSPD-125-140X	33.75
	.1875	.625	.005	II	1.090	.1875	2.0	QSPD-187-140	30.45	QSPD-187-140X	33.75
	.2500	.750	.005	II	1.353	.2500	2.5	QSPD-250-140	35.90	QSPD-250-140X	41.60
.3750	1.000	.005	II	1.353	.3750	2.5	QSPD-375-140	48.30	QSPD-375-140X	56.70	
.5000	1.000	.005	II	1.540	.5000	3.0	QSPD-500-140	65.10	QSPD-500-140X	76.80	

NEW

NEW

Quick Change – Holmaking Tools

Quick Change - Holmaking Tools

Combined Drill & Countersink Tools

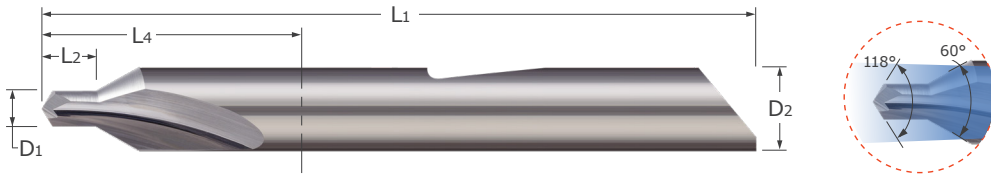

Quick Change - Holmaking Tools

- Designed for pre-drilling 60° live center holes
- Can be utilized for countersinking and spot drilling
- Coolant fed enabled shank design
- Proprietary Micro-Quik quick change system maximizes productivity through reliable accuracy and locational repeatability
- AlTiN coated option provides added lubricity and increased wear resistance in difficult to machine materials
- Solid carbide ■ CNC ground in the USA

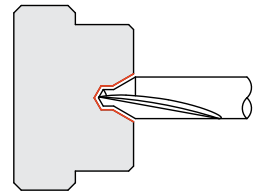

Drill Diameter	Drill Length	Length From Holder	Shank Diameter	Overall Length	Uncoated		AlTiN Coated	
					Tool #	Price	Tool #	Price
D1 $\begin{matrix} +.003" \\ -.000" \end{matrix}$	L2 $\begin{matrix} +.015" \\ -.000" \end{matrix}$	L4	D2 (h6)	L1	Tool #	Price	Tool #	Price
.025	.025	1.090	.1875	2.0	QDC-00	24.10	QDC-00X	27.15
.031	.031	1.090	.1875	2.0	QDC-01	24.10	QDC-01X	27.15
.047	.047	1.090	.1875	2.0	QDC-1	24.10	QDC-1X	27.15
D1 $\begin{matrix} +.003" \\ -.000" \end{matrix}$	L2 $\begin{matrix} +.030" \\ -.000" \end{matrix}$	L4	D2 (h6)	L1	Tool #	Price	Tool #	Price
.078	.078	1.090	.1875	2.0	QDC-2	24.10	QDC-2X	27.15
.109	.109	1.353	.2500	2.5	QDC-3	42.05	QDC-3X	48.05
.125	.125	1.353	.3125	2.5	QDC-4	56.20	QDC-4X	63.45
.188	.188	1.540	.5000	3.0	QDC-5	84.70	QDC-5X	96.05
.219	.219	1.540	.5000	3.0	QDC-6	84.70	QDC-6X	96.05

See pg 14-28 for quick change holder options

QSD

Quick Change – Holemaking Tools
Spade Drills

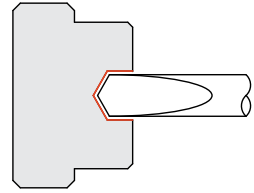
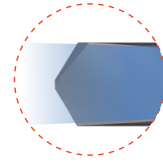
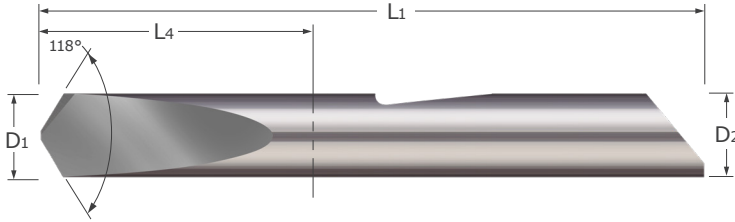

- Designed for drilling in hardened materials
- Excellent option when requiring holes free of retract marks in non-ferrous materials
- Coolant fed enabled shank design
- Point geometry designed for self-centering
- 118° tip angle
- Coolant fed enabled shank design
- Proprietary Micro-Quik quick change system maximizes productivity through reliable accuracy and locational repeatability
- AlTiN coated option provides added lubricity and increased wear resistance in difficult to machine materials
- Solid carbide ■ CNC ground in the USA

Quick Change – Holemaking Tools

Drill Diameter	Web Thickness	Length From Holder	Shank Diameter	Overall Length	Uncoated		AlTiN Coated	
					Tool #	Price	Tool #	Price
D1 $^{+.0000"}_{-.0005"}$	$^{+.001"}_{-.001"}$	L4	D2 (h6)	L1				
.0312	.010	.340	.1875	1.25	QSD-031	17.75	QSD-031X	20.55
.0625	.012	.590	.1875	1.50	QSD-062	18.45	QSD-062X	21.30
.0938	.016	.590	.1875	1.50	QSD-093	18.95	QSD-093X	21.80
.1250	.020	.590	.1875	1.50	QSD-125	20.80	QSD-125X	23.75
.1562	.025	1.090	.1875	2.00	QSD-156	22.70	QSD-156X	25.70
.1875	.028	1.090	.1875	2.00	QSD-187	26.45	QSD-187X	29.65
.2500	.035	.853	.2500	2.00	QSD-250	35.55	QSD-250X	39.10
.3125	.040	1.353	.3125	2.50	QSD-312	49.20	QSD-312X	53.25
.3750	.046	1.353	.3750	2.50	QSD-375	59.35	QSD-375X	63.75

See pg 14-28 for quick change holder options

Quick Change – Holmaking Tools

Countersink & Chamfer Tools

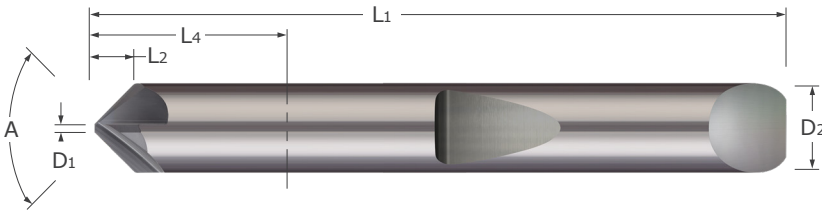

Quick Change – Holmaking Tools

- Designed for countersinking and chamfering
- Available in 60°, 82°, 90°, 100°, and 120° included angles
- Tip Diameter (D₁) is non-cutting
- Multi-tooth for greater metal removal rates
- Coolant fed enabled shank design
- Proprietary Micro-Quik quick change system maximizes productivity through reliable accuracy and locational repeatability
- AlTiN coated option provides added lubricity and increased wear resistance in difficult to machine materials
- Solid carbide ■ CNC ground in the USA

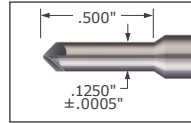

*QCS-125 tools feature a necked down shank

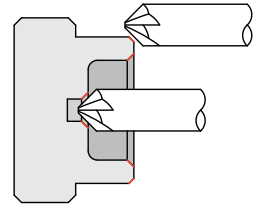

Included Angle	Tip Diameter	Length of Cut	Flutes	Length From Holder	Shank Diameter	Overall Length	Uncoated		AlTiN Coated	
							Tool #	Price	Tool #	Price
A ^{+1°} _{-1°}	D ₁ ^{+0.000"} _{-.003"}	L ₂		L ₄	D ₂ (h6)	L ₁				
60°	.030	.082	3	.590	.1875	1.5	QCS-125-060*	34.75	QCS-125-060X*	38.20
	.040	.128	4	1.090	.1875	2.0	QCS-187-060	34.75	QCS-187-060X	38.20
	.050	.173	6	1.353	.2500	2.5	QCS-250-060	39.60	QCS-250-060X	45.60
	.060	.219	6	1.353	.3125	2.5	QCS-312-060	53.20	QCS-312-060X	60.45
	.070	.264	6	1.353	.3750	2.5	QCS-375-060	65.95	QCS-375-060X	74.55
	.080	.364	6	1.540	.5000	3.0	QCS-500-060	91.85	QCS-500-060X	103.40
82°	.030	.055	3	.590	.1875	1.5	QCS-125-082*	34.75	QCS-125-082X*	38.20
	.040	.085	4	1.090	.1875	2.0	QCS-187-082	34.75	QCS-187-082X	38.20
	.050	.115	6	1.353	.2500	2.5	QCS-250-082	39.60	QCS-250-082X	45.60
	.060	.145	6	1.353	.3125	2.5	QCS-312-082	53.20	QCS-312-082X	60.45
	.070	.175	6	1.353	.3750	2.5	QCS-375-082	65.95	QCS-375-082X	74.55
	.080	.242	6	1.540	.5000	3.0	QCS-500-082	91.85	QCS-500-082X	103.40
90°	.030	.047	3	.590	.1875	1.5	QCS-125-090*	34.75	QCS-125-090X*	38.20
	.040	.074	4	1.090	.1875	2.0	QCS-187-090	34.75	QCS-187-090X	38.20
	.050	.100	6	1.353	.2500	2.5	QCS-250-090	39.60	QCS-250-090X	45.60
	.060	.126	6	1.353	.3125	2.5	QCS-312-090	53.20	QCS-312-090X	60.45
	.070	.152	6	1.353	.3750	2.5	QCS-375-090	65.95	QCS-375-090X	74.55
	.080	.210	6	1.540	.5000	3.0	QCS-500-090	91.85	QCS-500-090X	103.40
100°	.030	.040	3	.590	.1875	1.5	QCS-125-100*	34.75	QCS-125-100X*	38.20
	.040	.062	4	1.090	.1875	2.0	QCS-187-100	34.75	QCS-187-100X	38.20
	.050	.084	6	1.353	.2500	2.5	QCS-250-100	39.60	QCS-250-100X	45.60
	.060	.106	6	1.353	.3125	2.5	QCS-312-100	53.20	QCS-312-100X	60.45
	.070	.128	6	1.353	.3750	2.5	QCS-375-100	65.95	QCS-375-100X	74.55
	.080	.176	6	1.540	.5000	3.0	QCS-500-100	91.85	QCS-500-100X	103.40
120°	.030	.027	3	.590	.1875	1.5	QCS-125-120*	34.75	QCS-125-120X*	38.20
	.040	.043	4	1.090	.1875	2.0	QCS-187-120	34.75	QCS-187-120X	38.20
	.050	.058	6	1.353	.2500	2.5	QCS-250-120	39.60	QCS-250-120X	45.60
	.060	.073	6	1.353	.3125	2.5	QCS-312-120	53.20	QCS-312-120X	60.45
	.070	.088	6	1.353	.3750	2.5	QCS-375-120	65.95	QCS-375-120X	74.55
	.080	.121	6	1.540	.5000	3.0	QCS-500-120	91.85	QCS-500-120X	103.40

*QCS-125 tools feature a necked down shank

See pg 14-28 for quick change holder options

QSP

Quick Change – Blanks

Half Round

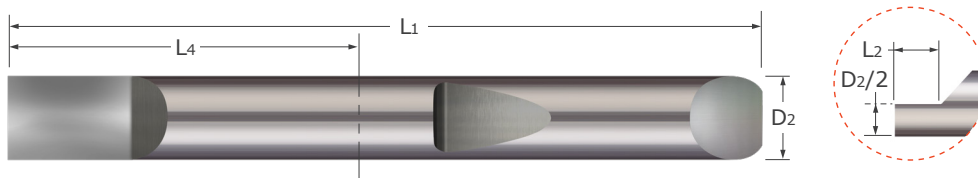

- Precision ground quick change blank designed for creating custom profiles requiring a split face
- Proprietary Micro-Quik quick change system maximizes productivity through reliable accuracy and locational repeatability
- Precision manufactured in the USA

Shank Diameter	Split Length*	Length from Holder	Overall Length	Tool Holder	
				Tool #	Price
D2 (h6)	L2 $\begin{matrix} +.005'' \\ -.000'' \end{matrix}$	L4	L1		
.1875	.375	.590	1.5	QSP-187-1.5	21.00
.1875	.375	1.090	2.0	QSP-187-2.0	22.40
.2500	.375	.853	2.0	QSP-250-2.0	23.80
.2500	.375	1.353	2.5	QSP-250-2.5	25.95
.2500	.375	1.853	3.0	QSP-250-3.0	28.05
.3125	.500	.853	2.0	QSP-312-2.0	31.95
.3125	.500	1.353	2.5	QSP-312-2.5	33.65
.3125	.500	1.853	3.0	QSP-312-3.0	37.75
.3750	.500	.853	2.0	QSP-375-2.0	40.45
.3750	.500	1.353	2.5	QSP-375-2.5	41.95
.3750	.500	1.853	3.0	QSP-375-3.0	45.00
.3750	.500	2.353	3.5	QSP-375-3.5	46.20
.3750	.500	2.853	4.0	QSP-375-4.0	51.25
.5000	.625	1.040	2.5	QSP-500-2.5	56.60
.5000	.625	1.540	3.0	QSP-500-3.0	59.50
.5000	.625	2.040	3.5	QSP-500-3.5	61.90
.5000	.625	2.540	4.0	QSP-500-4.0	65.10
.5000	.625	3.040	4.5	QSP-500-4.5	68.70

*Centerline +.001" / -.000"

Quick Change – Blanks

Full Round

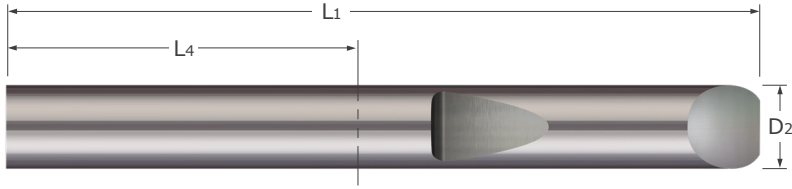

- Precision ground quick change blank designed for creating custom profiles
- Proprietary Micro-Quik quick change system maximizes productivity through reliable accuracy and locational repeatability
- Precision manufactured in the USA

Quick Change – Blanks

Shank Diameter	Length from Holder	Overall Length	Tool Holder	
			Tool #	Price
D ₂ (h6)	L ₄	L ₁		
.1875	.590	1.5	QSR-187-1.5	21.00
.1875	1.090	2.0	QSR-187-2.0	22.40
.2500	.853	2.0	QSR-250-2.0	23.80
.2500	1.353	2.5	QSR-250-2.5	25.95
.2500	1.853	3.0	QSR-250-3.0	28.05
.3125	.853	2.0	QSR-312-2.0	31.95
.3125	1.353	2.5	QSR-312-2.5	33.65
.3125	1.853	3.0	QSR-312-3.0	37.75
.3750	.853	2.0	QSR-375-2.0	40.45
.3750	1.353	2.5	QSR-375-2.5	41.95
.3750	1.853	3.0	QSR-375-3.0	45.00
.3750	2.353	3.5	QSR-375-3.5	46.20
.3750	2.853	4.0	QSR-375-4.0	51.25
.5000	1.040	2.5	QSR-500-2.5	56.60
.5000	1.540	3.0	QSR-500-3.0	59.50
.5000	2.040	3.5	QSR-500-3.5	61.90
.5000	2.540	4.0	QSR-500-4.0	65.10
.5000	3.040	4.5	QSR-500-4.5	68.70

See pg 14-28 for quick change holder options

MBB / MBBM

Standard – Boring Tools

Right Hand – Sharp – Miniature

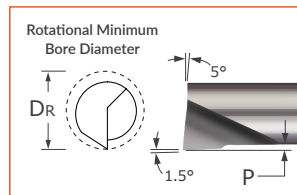

- Designed for facing and boring applications in bores .015" and larger
- Polished face for improved edge retention and chip evacuation while reducing galling
- Split face geometry provides optimal edge strength
- On center neck design allows for static and live/rotating applications
- Sharp corner profile ■ Lockdown flat automatically locates tool on center
- AlTiN coated option provides added lubricity and increased wear resistance in difficult to machine materials
- Solid carbide ■ CNC ground in the USA

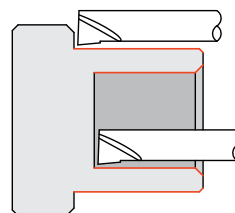

Head Width		Rotational Minimum Bore Diameter	Maximum Bore Depth	Projection	Centerline Offset	Shank Dia.	OAL	Uncoated		AlTiN Coated	
H	decimal equiv.	DR	L2 +.010" -.000" +.25mm -.00mm	P	F	D2 (h6)	L1	Tool #	Price	Tool #	Price
.0135	.0135	.015	.050	.0015	.0075	.1250	1.5	MBB-015050	39.50	MBB-015050X	43.70
.0135	.0135	.015	.075	.0015	.0075	.1250	1.5	MBB-015075	39.50	MBB-015075X	43.70
.45 mm	.0177	0.5 mm	2 mm	.05 mm	.25 mm	3 mm	38 mm	MBBM-005020	31.65	MBBM-005020X	35.70
.0180	.0180	.020	.050	.0020	.0100	.1250	1.5	MBB-020050	39.50	MBB-020050X	43.70
.0180	.0180	.020	.075	.0020	.0100	.1250	1.5	MBB-020075	39.50	MBB-020075X	43.70
.0180	.0180	.020	.100	.0020	.0100	.1250	1.5	MBB-020100	39.50	MBB-020100X	43.70
.54 mm	.0213	0.6 mm	2.5 mm	.06 mm	.30 mm	3 mm	38 mm	MBBM-006025	31.65	MBBM-006025X	35.70
.0225	.0225	.025	.050	.0025	.0125	.1250	1.5	MBB-025050	34.85	MBB-025050X	39.05
.0225	.0225	.025	.075	.0025	.0125	.1250	1.5	MBB-025075	34.85	MBB-025075X	39.05
.0225	.0225	.025	.100	.0025	.0125	.1250	1.5	MBB-025100	34.85	MBB-025100X	39.00
.0225	.0225	.025	.125	.0025	.0125	.1250	1.5	MBB-025125	34.85	MBB-025125X	39.05
.63 mm	.0248	0.7 mm	3 mm	.07 mm	.35 mm	3 mm	38 mm	MBBM-007030	31.65		
.63 mm	.0248	0.7 mm	4 mm	.07 mm	.35 mm	3 mm	38 mm	MBBM-007040	31.65		
.0275	.0275	.030	.075	.0025	.0150	.1250	1.5	MBB-030075	34.85	MBB-030075X	39.05
.0275	.0275	.030	.100	.0025	.0150	.1250	1.5	MBB-030100	34.85	MBB-030100X	39.00
.0275	.0275	.030	.125	.0025	.0150	.1250	1.5	MBB-030125	34.85	MBB-030125X	39.05
.0275	.0275	.030	.150	.0025	.0150	.1250	1.5	MBB-030150	34.85	MBB-030150X	39.05
.72 mm	.0283	0.8 mm	3 mm	.08 mm	.40 mm	3 mm	38 mm	MBBM-008030	31.65	MBBM-008030X	35.70
.72 mm	.0283	0.8 mm	4 mm	.08 mm	.40 mm	3 mm	38 mm	MBBM-008040	31.65	MBBM-008040X	35.70
.0320	.0320	.035	.075	.0030	.0175	.1250	1.5	MBB-035075	34.85	MBB-035075X	39.05
.0320	.0320	.035	.100	.0030	.0175	.1250	1.5	MBB-035100	34.85	MBB-035100X	39.00
.0320	.0320	.035	.150	.0030	.0175	.1250	1.5	MBB-035150	34.85	MBB-035150X	39.00
.0320	.0320	.035	.200	.0030	.0175	.1250	1.5	MBB-035200	34.85	MBB-035200X	39.05
.81 mm	.0317	0.9 mm	4 mm	.09 mm	.45 mm	3 mm	38 mm	MBBM-009040	31.65		
.81 mm	.0317	0.9 mm	5 mm	.09 mm	0.45 mm	3 mm	38 mm	MBBM-009050	31.65		
.91 mm	.0357	1 mm	4 mm	.09 mm	0.50 mm	3 mm	38 mm	MBBM-010040	31.65		
.0365	.0365	.040	.100	.0035	.0200	.1250	1.5	MBB-040100	34.85	MBB-040100X	39.00
.0365	.0365	.040	.150	.0035	.0200	.1250	1.5	MBB-040150	34.85	MBB-040150X	39.00
.0365	.0365	.040	.200	.0035	.0200	.1250	1.5	MBB-040200	34.85	MBB-040200X	39.00

Continued on next page

See pgs 33-37 for standard tool holders

See pg 306 for tool set options

Standard – Boring Tools

MBB / MBBM

Right Hand – Sharp – Miniature (cont.)

Continued from previous page

Head Width		Rotational Minimum Bore Diameter	Maximum Bore Depth	Projection	Centerline Offset	Shank Dia.	OAL	Uncoated		AITIN Coated	
H	decimal equiv.	D _R	L ₂ +.010" -.000" +.25mm -.00mm	P	F	D ₂ (h6)	L ₁	Tool #	Price	Tool #	Price
.0405	.0405	.045	.100	.0045	.0225	.1250	1.5	MBB-045100	34.85	MBB-045100X	39.00
.0405	.0405	.045	.150	.0045	.0225	.1250	1.5	MBB-045150	34.85	MBB-045150X	39.00
.0405	.0405	.045	.200	.0045	.0225	.1250	1.5	MBB-045200	34.85	MBB-045200X	39.00
.0440	.0440	.050	.100	.0060	.0250	.1250	1.5	MBB-050100	34.85	MBB-050100X	39.05
.0440	.0440	.050	.150	.0060	.0250	.1250	1.5	MBB-050150	34.85	MBB-050150X	39.00
.0440	.0440	.050	.200	.0060	.0250	.1250	1.5	MBB-050200	34.85	MBB-050200X	39.05
.0440	.0440	.050	.300	.0060	.0250	.1250	1.5	MBB-050300	34.85	MBB-050300X	39.05
.0525	.0525	.060	.150	.0075	.0300	.1250	1.5	MBB-060150	34.85	MBB-060150X	39.00
.0525	.0525	.060	.200	.0075	.0300	.1250	1.5	MBB-060200	34.85	MBB-060200X	39.00
.0525	.0525	.060	.300	.0075	.0300	.1250	1.5	MBB-060300	34.85	MBB-060300X	39.05
.0525	.0525	.060	.400	.0075	.0300	.1250	1.5	MBB-060400	34.85	MBB-060400X	39.05
.0525	.0525	.060	.500	.0075	.0300	.1250	1.5	MBB-060500	34.85	MBB-060500X	39.05
.0625	.0625	.070	.150	.0075	.0350	.1250	1.5	MBB-070150	34.85	MBB-070150X	39.05
.0625	.0625	.070	.200	.0075	.0350	.1250	1.5	MBB-070200	34.85	MBB-070200X	39.00
.0625	.0625	.070	.300	.0075	.0350	.1250	1.5	MBB-070300	34.85	MBB-070300X	39.00
.0625	.0625	.070	.400	.0075	.0350	.1250	1.5	MBB-070400	34.85	MBB-070400X	39.05
.0625	.0625	.070	.500	.0075	.0350	.1250	1.5	MBB-070500	34.85	MBB-070500X	39.05
.0700	.0700	.080	.150	.0100	.0400	.1250	1.5	MBB-080150	34.85	MBB-080150X	39.00
.0700	.0700	.080	.200	.0100	.0400	.1250	1.5	MBB-080200	34.85	MBB-080200X	39.00
.0700	.0700	.080	.300	.0100	.0400	.1250	1.5	MBB-080300	34.85	MBB-080300X	39.05
.0700	.0700	.080	.500	.0100	.0400	.1250	1.5	MBB-080500	34.85	MBB-080500X	39.05
.0700	.0700	.080	.600	.0100	.0400	.1250	1.5	MBB-080600	34.85	MBB-080600X	39.05
.0800	.0800	.090	.200	.0100	.0450	.1250	1.5	MBB-090200	34.85	MBB-090200X	39.05
.0800	.0800	.090	.300	.0100	.0450	.1250	1.5	MBB-090300	34.85	MBB-090300X	39.00
.0800	.0800	.090	.500	.0100	.0450	.1250	1.5	MBB-090500	34.85	MBB-090500X	39.05
.0800	.0800	.090	.700	.0100	.0450	.1250	1.5	MBB-090700	34.85	MBB-090700X	39.05
.0875	.0875	.100	.200	.0125	.0500	.1250	1.5	MBB-100200	34.85	MBB-100200X	39.00
.0875	.0875	.100	.300	.0125	.0500	.1250	1.5	MBB-100300	34.85	MBB-100300X	39.00
.0875	.0875	.100	.500	.0125	.0500	.1250	1.5	MBB-100500	34.85	MBB-100500X	39.05
.0875	.0875	.100	.700	.0125	.0500	.1250	1.5	MBB-100700	34.85	MBB-100700X	39.05
.0875	.0875	.100	.800	.0125	.0500	.1250	2.0	MBB-100800	34.85	MBB-100800X	39.05

Standard – Boring Tools

See pgs 33-37 for standard tool holders

See pg 306 for tool set options

BBS / BBM

Standard – Boring Tools

Right Hand – Sharp

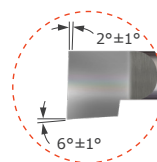
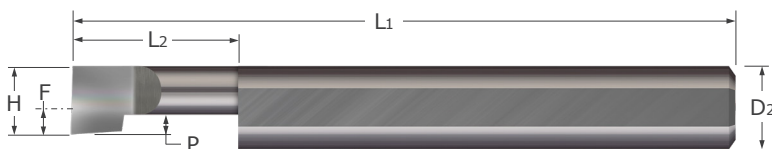

- Designed for facing and boring applications in bores .044" and larger
- Polished split face for improved edge retention and chip evacuation while reducing galling
- Split face geometry provides optimal edge strength
- Sharp corner profile
- Lockdown flat automatically locates tool on center
- Coating options provide added lubricity and increased wear resistance in difficult to machine materials
- Solid carbide ■ CNC ground in the USA

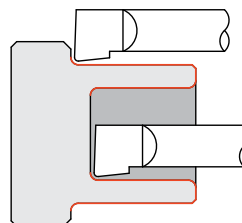

Head Width	Min. Bore Dia*	Max. Bore Depth	Projection	Centerline Offset	Shank Dia.	OAL	Uncoated		TIN Coated		AITIN Coated		
							Tool #	Price	Tool #	Price	Tool #	Price	
H	decimal equiv.	L2	P	F	D2 (h6)	L1							
		+.050" -.000" +1.24mm -.00mm											
1 mm	.0394	1.12 mm	4 mm	.25 mm	-1 mm	4 mm	50 mm	BBM-040104	25.05	BBM-040104G	28.35	BBM-040104X	29.25
1 mm	.0394	1.12 mm	6 mm	.25 mm	-1 mm	4 mm	50 mm	BBM-040106	25.05	BBM-040106G	28.35	BBM-040106X	29.25
1 mm	.0394	1.12 mm	8 mm	.25 mm	-1 mm	4 mm	50 mm	BBM-040108	25.05	BBM-040108G	28.35	BBM-040108X	29.25
.050	.0500	.0550	.150	.012	-.0125	.1250	1.5	BB-050150S	25.55	BB-050150SG	28.65	BB-050150SX	29.30
.050	.0500	.0550	.200	.012	-.0125	.1250	1.5	BB-050200S	25.55	BB-050200SG	28.65	BB-050200SX	29.30
.050	.0500	.0550	.300	.012	-.0125	.1250	1.5	BB-050300S	25.55	BB-050300SG	28.65	BB-050300SX	29.30
.050	.0500	.0550	.400	.012	-.0125	.1250	1.5	BB-050400S	25.55	BB-050400SG	28.65	BB-050400SX	29.30
.060	.0600	.0700	.150	.015	-.0025	.1250	1.5	BB-060150S	25.55	BB-060150SG	28.65	BB-060150SX	29.30
.060	.0600	.0700	.200	.015	-.0025	.1250	1.5	BB-060200S	25.55	BB-060200SG	28.65	BB-060200SX	29.30
.060	.0600	.0700	.300	.015	-.0025	.1250	1.5	BB-060300S	25.55	BB-060300SG	28.65	BB-060300SX	29.30
.060	.0600	.0700	.400	.015	-.0025	.1250	1.5	BB-060400S	25.55	BB-060400SG	28.65	BB-060400SX	29.30
.060	.0600	.0700	.500	.015	-.0025	.1250	1.5	BB-060500S	25.55	BB-060500SG	28.65	BB-060500SX	29.30
.070	.0700	.0800	.150	.015	.0075	.1250	1.5	BB-070150S	25.55			BB-070150SX	29.30
.070	.0700	.0800	.200	.015	.0075	.1250	1.5	BB-070200S	25.55			BB-070200SX	29.30
.070	.0700	.0800	.300	.015	.0075	.1250	1.5	BB-070300S	25.55			BB-070300SX	29.30
2 mm	.0787	2.25 mm	4 mm	.50 mm	0 mm	4 mm	50 mm	BBM-040204	25.05	BBM-040204G	28.35	BBM-040204X	29.25
2 mm	.0787	2.25 mm	6 mm	.50 mm	0 mm	4 mm	50 mm	BBM-040206	25.05	BBM-040206G	28.35	BBM-040206X	29.25
2 mm	.0787	2.25 mm	8 mm	.50 mm	0 mm	4 mm	50 mm	BBM-040208	25.05	BBM-040208G	28.35	BBM-040208X	29.25
2 mm	.0787	2.25 mm	10 mm	.50 mm	0 mm	4 mm	50 mm	BBM-040210	25.05			BBM-040210X	29.25
2 mm	.0787	2.25 mm	13 mm	.50 mm	0 mm	4 mm	50 mm	BBM-040213	25.05	BBM-040213G	28.35	BBM-040213X	29.25
.080	.0800	.0900	.150	.020	.0175	.1250	1.5	BB-080150S	25.55	BB-080150SG	28.65	BB-080150SX	29.30
.080	.0800	.0900	.200	.020	.0175	.1250	1.5	BB-080200S	25.55	BB-080200SG	28.65	BB-080200SX	29.30
.080	.0800	.0900	.300	.020	.0175	.1250	1.5	BB-080300S	25.55	BB-080300SG	28.65	BB-080300SX	29.30

*Suggested Minimum Bore Diameter to accommodate chip evacuation and retract clearance in static (not live) applications.

Continued on next page

Standard – Boring Tools

BBS / BBM

Right Hand – Sharp (cont.)

Continued from previous page

Head Width		Min. Bore Dia*	Max. Bore Depth	Projection	Centerline Offset	Shank Dia.	OAL	Uncoated		TIN Coated		AITIN Coated	
H	decimal equiv.	L ₂	$\begin{matrix} +.050'' \\ -.000'' \\ +1.24\text{mm} \\ -.00\text{mm} \end{matrix}$	P	F	D ₂ (h6)	L ₁	Tool #	Price	Tool #	Price	Tool #	Price
.080	.0800	.0900	.400	.020	.0175	.1250	1.5	BB-080400S	25.55	BB-080400SG	28.65	BB-080400SX	29.30
.080	.0800	.0900	.500	.020	.0175	.1250	1.5	BB-080500S	25.55	BB-080500SG	28.65	BB-080500SX	29.30
.080	.0800	.0900	.600	.020	.0175	.1250	1.5	BB-080600S	25.55	BB-080600SG	28.65	BB-080600SX	29.30
.090	.0900	.1000	.150	.020	.0275	.1250	1.5	BB-090150S	25.55	BB-090150SG	29.75	BB-090150SX	29.75
.090	.0900	.1000	.200	.020	.0275	.1250	1.5	BB-090200S	25.55	BB-090200SG	29.75	BB-090200SX	29.75
.090	.0900	.1000	.300	.020	.0275	.1250	1.5	BB-090300S	25.55			BB-090300SX	29.30
.090	.0900	.1000	.400	.020	.0275	.1250	1.5	BB-090400S	25.55	BB-090400SG	29.75	BB-090400SX	29.75
.090	.0900	.1000	.500	.020	.0275	.1250	1.5	BB-090500S	25.55	BB-090500SG	29.75	BB-090500SX	29.75
.100	.1000	.1100	.150	.025	.0375	.1250	1.5	BB-100150S	25.55	BB-100150SG	28.65	BB-100150SX	29.30
.100	.1000	.1100	.200	.025	.0375	.1250	1.5	BB-100200S	25.55	BB-100200SG	28.65	BB-100200SX	29.30
.100	.1000	.1100	.300	.025	.0375	.1250	1.5	BB-100300S	25.55	BB-100300SG	28.65	BB-100300SX	29.30
.100	.1000	.1100	.400	.025	.0375	.1250	1.5	BB-100400S	25.55	BB-100400SG	28.65	BB-100400SX	29.30
.100	.1000	.1100	.500	.025	.0375	.1250	1.5	BB-100500S	25.55	BB-100500SG	28.65	BB-100500SX	29.30
.100	.1000	.1100	.600	.025	.0375	.1250	1.5	BB-100600S	25.55	BB-100600SG	28.65	BB-100600SX	29.30
.100	.1000	.1100	.700	.025	.0375	.1250	1.5	BB-100700S	25.55	BB-100700SG	28.65	BB-100700SX	29.30
.110	.1100	.1220	.150	.027	.0475	.1250	1.5	BB-110150S	25.55	BB-110150SG	28.65	BB-110150SX	29.30
.110	.1100	.1220	.200	.027	.0475	.1250	1.5	BB-110200S	25.55	BB-110200SG	28.65	BB-110200SX	29.30
.110	.1100	.1220	.300	.027	.0475	.1250	1.5	BB-110300S	25.55	BB-110300SG	28.65	BB-110300SX	29.30
.110	.1100	.1220	.400	.027	.0475	.1250	1.5	BB-110400S	25.55	BB-110400SG	28.65	BB-110400SX	29.30
.110	.1100	.1220	.500	.027	.0475	.1250	1.5	BB-110500S	25.55	BB-110500SG	28.65	BB-110500SX	29.30
.110	.1100	.1220	.600	.027	.0475	.1250	1.5	BB-110600S	25.55	BB-110600SG	28.65	BB-110600SX	29.30
.110	.1100	.1220	.700	.027	.0475	.1250	1.5	BB-110700S	25.55	BB-110700SG	28.65	BB-110700SX	29.30
3 mm	.1181	3.3 mm	8 mm	.75 mm	1 mm	4 mm	50 mm	BBM-040308	25.05	BBM-040308G	28.35	BBM-040308X	29.25
3 mm	.1181	3.3 mm	10 mm	.75 mm	1 mm	4 mm	50 mm	BBM-040310	25.05	BBM-040310G	28.35	BBM-040310X	29.25
3 mm	.1181	3.3 mm	13 mm	.75 mm	1 mm	4 mm	50 mm	BBM-040313	25.05	BBM-040313G	28.35	BBM-040313X	29.25
3 mm	.1181	3.3 mm	15 mm	.75 mm	1 mm	4 mm	50 mm	BBM-040315	25.05	BBM-040315G	28.35	BBM-040315X	29.25
3 mm	.1181	3.3 mm	20 mm	.75 mm	1 mm	4 mm	50 mm	BBM-040320	25.05	BBM-040320G	28.35	BBM-040320X	29.25
.120	.1200	.1320	.250	.030	.0263	.1875	2.0	BB-120250S	27.25	BB-120250SG	30.70	BB-120250SX	31.60
.120	.1200	.1320	.350	.030	.0263	.1875	2.0	BB-120350S	27.25	BB-120350SG	30.70	BB-120350SX	31.60
.120	.1200	.1320	.500	.030	.0263	.1875	2.0	BB-120500S	27.25	BB-120500SG	30.70	BB-120500SX	31.60
.120	.1200	.1320	.600	.030	.0263	.1875	2.0	BB-120600S	27.25	BB-120600SG	30.70	BB-120600SX	31.60
.120	.1200	.1320	.700	.030	.0263	.1875	2.0	BB-120700S	27.25	BB-120700SG	30.70	BB-120700SX	31.60
.120	.1200	.1320	.800	.030	.0263	.1875	2.0	BB-120800S	27.25	BB-120800SG	30.70	BB-120800SX	31.60
.140	.1400	.1520	.250	.035	.0463	.1875	2.0	BB-140250S	27.25	BB-140250SG	30.70	BB-140250SX	31.60
.140	.1400	.1520	.400	.035	.0463	.1875	2.0	BB-140400S	27.25	BB-140400SG	30.70	BB-140400SX	31.60
.140	.1400	.1520	.500	.035	.0463	.1875	2.0	BB-140500S	27.25	BB-140500SG	30.70	BB-140500SX	31.60
.140	.1400	.1520	.600	.035	.0463	.1875	2.0	BB-140600S	27.25	BB-140600SG	30.70	BB-140600SX	31.60
.140	.1400	.1520	.700	.035	.0463	.1875	2.0	BB-140700S	27.25			BB-140700SX	31.60
.140	.1400	.1520	.750	.035	.0463	.1875	2.0	BB-140750S	27.25	BB-140750SG	30.70	BB-140750SX	31.60
.140	.1400	.1520	.800	.035	.0463	.1875	2.0	BB-140800S	27.25	BB-140800SG	30.70	BB-140800SX	31.60
.140	.1400	.1520	.900	.035	.0463	.1875	2.0	BB-140900S	27.25	BB-140900SG	32.00	BB-140900SX	32.00

*Suggested Minimum Bore Diameter to accommodate chip evacuation and retract clearance in static (not live) applications.

Continued on next page

Standard – Boring Tools

BBS / BBM

Standard – Boring Tools

Right Hand – Sharp (cont.)

Continued from previous page

Head Width		Min. Bore Dia*	Max. Bore Depth	Projection	Centerline Offset	Shank Dia.	OAL	Uncoated		TIN Coated		AITIN Coated	
H	decimal equiv.	L2	$+.050''$ $-.000''$ $+1.24mm$ $-.00mm$	P	F	D2 (h6)	L1	Tool #	Price	Tool #	Price	Tool #	Price
4 mm	.1575	4.4 mm	8 mm	1 mm	2 mm	4 mm	50 mm	BBM-040408	25.05			BBM-040408X	29.25
4 mm	.1575	4.4 mm	10 mm	1 mm	2 mm	4 mm	50 mm	BBM-040410	25.05	BBM-040410G	28.35	BBM-040410X	29.25
4 mm	.1575	4.4 mm	15 mm	1 mm	2 mm	4 mm	50 mm	BBM-040415	25.05	BBM-040415G	28.35	BBM-040415X	29.25
4 mm	.1575	4.4 mm	20 mm	1 mm	2 mm	4 mm	50 mm	BBM-040420	25.05	BBM-040420G	28.35		
4 mm	.1575	4.4 mm	25 mm	1 mm	2 mm	4 mm	50 mm	BBM-040425	25.05			BBM-040425X	29.25
.160	.1600	.1760	.250	.040	.0663	.1875	2.0	BB-160250S	27.25	BB-160250SG	30.70	BB-160250SX	31.60
.160	.1600	.1760	.400	.040	.0663	.1875	2.0	BB-160400S	27.25	BB-160400SG	30.70	BB-160400SX	31.60
.160	.1600	.1760	.500	.040	.0663	.1875	2.0	BB-160500S	27.25	BB-160500SG	30.70	BB-160500SX	31.60
.160	.1600	.1760	.600	.040	.0663	.1875	2.0	BB-160600S	27.25	BB-160600SG	30.70	BB-160600SX	31.60
.160	.1600	.1760	.750	.040	.0663	.1875	2.0	BB-160750S	27.25	BB-160750SG	30.70	BB-160750SX	31.60
.160	.1600	.1760	.900	.040	.0663	.1875	2.0	BB-160900S	27.25	BB-160900SG	30.70	BB-160900SX	31.60
.160	.1600	.1760	1.000	.040	.0663	.1875	2.0	BB-1601000S	27.25	BB-1601000SG	30.70	BB-1601000SX	31.60
.180	.1800	.1960	.350	.045	.0550	.2500	2.5	BB-180350S	29.45	BB-180350SG	34.30	BB-180350SX	35.50
.180	.1800	.1960	.500	.045	.0550	.2500	2.5	BB-180500S	29.45	BB-180500SG	34.30	BB-180500SX	35.50
.180	.1800	.1960	.600	.045	.0550	.2500	2.5	BB-180600S	29.45	BB-180600SG	34.30	BB-180600SX	35.50
.180	.1800	.1960	.750	.045	.0550	.2500	2.5	BB-180750S	29.45	BB-180750SG	34.30	BB-180750SX	35.50
.180	.1800	.1960	.900	.045	.0550	.2500	2.5	BB-180900S	29.45	BB-180900SG	34.30	BB-180900SX	35.50
.180	.1800	.1960	1.000	.045	.0550	.2500	2.5	BB-1801000S	29.45	BB-1801000SG	34.30	BB-1801000SX	35.50
.180	.1800	.1960	1.100	.045	.0550	.2500	2.5	BB-1801100S	29.45	BB-1801100SG	34.30	BB-1801100SX	35.50
.180	.1800	.1960	1.250	.045	.0550	.2500	2.5	BB-1801250S	29.45	BB-1801250SG	34.30	BB-1801250SX	35.50
.180	.1800	.1960	1.500	.045	.0550	.2500	2.5	BB-1801500S	29.45	BB-1801500SG	34.30	BB-1801500SX	35.50
5 mm	.1969	5.4 mm	10 mm	1.25 mm	2 mm	6 mm	57 mm	BBM-060510	28.05	BBM-060510G	32.80	BBM-060510X	34.10
5 mm	.1969	5.4 mm	15 mm	1.25 mm	2 mm	6 mm	57 mm	BBM-060515	28.05	BBM-060515G	32.80		
5 mm	.1969	5.4 mm	20 mm	1.25 mm	2 mm	6 mm	57 mm	BBM-060520	28.05	BBM-060520G	32.80	BBM-060520X	34.10
5 mm	.1969	5.4 mm	25 mm	1.25 mm	2 mm	6 mm	57 mm	BBM-060525	28.05				
5 mm	.1969	5.4 mm	28 mm	1.25 mm	2 mm	6 mm	57 mm	BBM-060528	28.05	BBM-060528G	32.80	BBM-060528X	34.10
.200	.2000	.2160	.400	.050	.0750	.2500	2.5	BB-200400S	29.45	BB-200400SG	34.30	BB-200400SX	35.50
.200	.2000	.2160	.500	.050	.0750	.2500	2.5	BB-200500S	29.45	BB-200500SG	34.30	BB-200500SX	35.50
.200	.2000	.2160	.600	.050	.0750	.2500	2.5	BB-200600S	29.45	BB-200600SG	34.30	BB-200600SX	35.50
.200	.2000	.2160	.700	.050	.0750	.2500	2.5	BB-200700S	29.45	BB-200700SG	34.30	BB-200700SX	35.50
.200	.2000	.2160	.800	.050	.0750	.2500	2.5	BB-200800S	29.45	BB-200800SG	34.30	BB-200800SX	35.50
.200	.2000	.2160	.900	.050	.0750	.2500	2.5	BB-200900S	29.45	BB-200900SG	34.30	BB-200900SX	35.50
.200	.2000	.2160	1.000	.050	.0750	.2500	2.5	BB-2001000S	29.45	BB-2001000SG	34.30	BB-2001000SX	35.50
.200	.2000	.2160	1.100	.050	.0750	.2500	2.5	BB-2001100S	29.45			BB-2001100SX	35.50
.200	.2000	.2160	1.200	.050	.0750	.2500	2.5	BB-2001200S	29.45				
.200	.2000	.2160	1.300	.050	.0750	.2500	2.5	BB-2001300S	29.45			BB-2001300SX	35.50
.230	.2300	.2500	.400	.057	.0738	.3125	2.5	BB-230400S	40.35	BB-230400SG	47.45	BB-230400SX	47.60
.230	.2300	.2500	.500	.057	.0738	.3125	2.5	BB-230500S	40.35	BB-230500SG	47.45	BB-230500SX	47.60
.230	.2300	.2500	.600	.057	.0738	.3125	2.5	BB-230600S	40.35	BB-230600SG	47.45	BB-230600SX	47.60
.230	.2300	.2500	.700	.057	.0738	.3125	2.5	BB-230700S	40.35	BB-230700SG	47.45	BB-230700SX	47.60
.230	.2300	.2500	.800	.057	.0738	.3125	2.5	BB-230800S	40.35	BB-230800SG	47.45	BB-230800SX	47.60
.230	.2300	.2500	.900	.057	.0738	.3125	2.5	BB-230900S	40.35	BB-230900SG	47.45	BB-230900SX	47.60
.230	.2300	.2500	1.000	.057	.0738	.3125	2.5	BB-2301000S	40.35	BB-2301000SG	47.45	BB-2301000SX	47.60
.230	.2300	.2500	1.100	.057	.0738	.3125	2.5	BB-2301100S	40.35	BB-2301100SG	47.45	BB-2301100SX	47.60
.230	.2300	.2500	1.150	.057	.0738	.3125	2.5	BB-2301150S	40.35	BB-2301150SG	47.45	BB-2301150SX	47.60

*Suggested Minimum Bore Diameter to accommodate chip evacuation and retract clearance in static (not live) applications.

Continued on next page

See pgs 33-37 for standard tool holders

Standard – Boring Tools

Standard – Boring Tools

BBS / BBM

Right Hand – Sharp (cont.)

Continued from previous page

Head Width		Min. Bore Dia*	Max. Bore Depth	Projection	Centerline Offset	Shank Dia.	OAL	Uncoated		TIN Coated		AITIN Coated	
H	decimal equiv.	L ₂	$+ .050''$ $- .000''$ $+ 1.24mm$ $- .00mm$	P	F	D ₂ (h6)	L ₁	Tool #	Price	Tool #	Price	Tool #	Price
.230	.2300	.2500	1.200	.057	.0738	.3125	2.5	BB-2301200S	40.35	BB-2301200SG	47.45	BB-2301200SX	47.60
.230	.2300	.2500	1.250	.057	.0738	.3125	2.5	BB-2301250S	40.35	BB-2301250SG	47.45	BB-2301250SX	47.60
.230	.2300	.2500	1.400	.057	.0738	.3125	2.5	BB-2301400S	40.35	BB-2301400SG	47.45	BB-2301400SX	47.60
.230	.2300	.2500	1.500	.057	.0738	.3125	2.5	BB-2301500S	40.35	BB-2301500SG	47.45	BB-2301500SX	47.60
.230	.2300	.2500	1.600	.057	.0738	.3125	2.5	BB-2301600S	40.35	BB-2301600SG	47.45	BB-2301600SX	47.60
6 mm	.2362	6.5 mm	10 mm	1.50 mm	3 mm	6 mm	57 mm	BBM-060610	28.05	BBM-060610G	32.80		
6 mm	.2362	6.5 mm	15 mm	1.50 mm	3 mm	6 mm	57 mm	BBM-060615	28.05	BBM-060615G	32.80	BBM-060615X	34.10
6 mm	.2362	6.5 mm	20 mm	1.50 mm	3 mm	6 mm	57 mm	BBM-060620	28.05			BBM-060620X	34.10
6 mm	.2362	6.5 mm	25 mm	1.50 mm	3 mm	6 mm	57 mm	BBM-060625	28.05	BBM-060625G	32.80	BBM-060625X	34.10
6 mm	.2362	6.5 mm	30 mm	1.50 mm	3 mm	6 mm	57 mm	BBM-060630	28.05	BBM-060630G	32.80		
6 mm	.2362	6.5 mm	35 mm	1.50 mm	3 mm	6 mm	57 mm	BBM-060635	28.05	BBM-060635G	32.80	BBM-060635X	34.10
6 mm	.2362	6.5 mm	38 mm	1.50 mm	3 mm	6 mm	57 mm	BBM-060638	28.05	BBM-060638G	32.80	BBM-060638X	34.10
.260	.2600	.2800	.500	.065	.1038	.3125	2.5	BB-260500S	40.35	BB-260500SG	47.60	BB-260500SX	47.60
.260	.2600	.2800	.750	.065	.1038	.3125	2.5	BB-260750S	40.35	BB-260750SG	47.60	BB-260750SX	47.60
.260	.2600	.2800	1.000	.065	.1038	.3125	2.5	BB-2601000S	40.35	BB-2601000SG	47.60	BB-2601000SX	47.60
.260	.2600	.2800	1.250	.065	.1038	.3125	2.5	BB-2601250S	40.35	BB-2601250SG	47.60	BB-2601250SX	47.60
7 mm	.2755	7.5 mm	15 mm	1.75 mm	3 mm	8 mm	63 mm	BBM-080715	38.25	BBM-080715G	45.25	BBM-080715X	46.85
7 mm	.2755	7.5 mm	20 mm	1.75 mm	3 mm	8 mm	63 mm	BBM-080720	38.25				
7 mm	.2755	7.5 mm	25 mm	1.75 mm	3 mm	8 mm	63 mm	BBM-080725	38.25				
7 mm	.2755	7.5 mm	32 mm	1.75 mm	3 mm	8 mm	63 mm	BBM-080732	38.25	BBM-080732G	45.25		
7 mm	.2755	7.5 mm	38 mm	1.75 mm	3 mm	8 mm	63 mm	BBM-080738	38.25	BBM-080738G	45.25		
7 mm	.2755	7.5 mm	46 mm	1.75 mm	3 mm	8 mm	63 mm	BBM-080746	38.25	BBM-080746G	45.25	BBM-080746X	46.85
.290	.2900	.3100	.500	.072	.1338	.3125	2.5	BB-290500S	40.35	BB-290500SG	47.45	BB-290500SX	47.60
.290	.2900	.3100	.600	.072	.1338	.3125	2.5	BB-290600S	40.35	BB-290600SG	47.45	BB-290600SX	47.60
.290	.2900	.3100	.750	.072	.1338	.3125	2.5	BB-290750S	40.35	BB-290750SG	47.45	BB-290750SX	47.60
.290	.2900	.3100	.900	.072	.1338	.3125	2.5	BB-290900S	40.35	BB-290900SG	47.45	BB-290900SX	47.60
.290	.2900	.3100	1.000	.072	.1338	.3125	2.5	BB-2901000S	40.35	BB-2901000SG	47.45	BB-2901000SX	47.60
.290	.2900	.3100	1.100	.072	.1338	.3125	2.5	BB-2901100S	40.35	BB-2901100SG	47.45	BB-2901100SX	47.60
.290	.2900	.3100	1.250	.072	.1338	.3125	2.5	BB-2901250S	40.35	BB-2901250SG	47.45	BB-2901250SX	47.60
.290	.2900	.3100	1.350	.072	.1338	.3125	2.5	BB-2901350S	40.35	BB-2901350SG	47.45	BB-2901350SX	47.60
.290	.2900	.3100	1.500	.072	.1338	.3125	2.5	BB-2901500S	40.35	BB-2901500SG	47.45	BB-2901500SX	47.60
.290	.2900	.3100	1.600	.072	.1338	.3125	2.5	BB-2901600S	40.35	BB-2901600SG	47.45	BB-2901600SX	47.60
.290	.2900	.3100	1.750	.072	.1338	.3125	2.5	BB-2901750S	40.35	BB-2901750SG	47.45	BB-2901750SX	47.60
8 mm	.3150	8.5 mm	13 mm	2 mm	4 mm	8 mm	63 mm	BBM-080813	38.25	BBM-080813G	45.25	BBM-080813X	46.85
8 mm	.3150	8.5 mm	20 mm	2 mm	4 mm	8 mm	63 mm	BBM-080820	38.25	BBM-080820G	45.25		
8 mm	.3150	8.5 mm	25 mm	2 mm	4 mm	8 mm	63 mm	BBM-080825	38.25	BBM-080825G	45.25	BBM-080825X	46.85
8 mm	.3150	8.5 mm	32 mm	2 mm	4 mm	8 mm	63 mm	BBM-080832	38.25	BBM-080832G	45.25		
8 mm	.3150	8.5 mm	38 mm	2 mm	4 mm	8 mm	63 mm	BBM-080838	38.25	BBM-080838G	45.25	BBM-080838X	46.85
8 mm	.3150	8.5 mm	46 mm	2 mm	4 mm	8 mm	63 mm	BBM-080846	38.25	BBM-080846G	45.25		
8 mm	.3150	8.5 mm	50 mm	2 mm	4 mm	8 mm	63 mm	BBM-080850	38.25	BBM-080850G	45.25		

*Suggested Minimum Bore Diameter to accommodate chip evacuation and retract clearance in static (not live) applications.

Continued on next page

See pgs 33-37 for standard tool holders

BBS / BBM

Standard – Boring Tools

Right Hand – Sharp (cont.)

Continued from previous page

Head Width		Min. Bore Dia*	Max. Bore Depth	Projection	Centerline Offset	Shank Dia.	OAL	Uncoated		TIN Coated		AITIN Coated	
H	decimal equiv.	L ₂	$\begin{matrix} +.050'' \\ -.000'' \\ +1.24\text{mm} \\ -.00\text{mm} \end{matrix}$	P	F	D ₂ (h6)	L ₁	Tool #	Price	Tool #	Price	Tool #	Price
.320	.3200	.3400	.500	.080	.1325	.3750	2.5	BB-320500S	55.55	BB-320500SG	63.25	BB-320500SX	64.15
.320	.3200	.3400	.600	.080	.1325	.3750	2.5	BB-320600S	55.55	BB-320600SG	63.25	BB-320600SX	64.15
.320	.3200	.3400	.750	.080	.1325	.3750	2.5	BB-320750S	55.55	BB-320750SG	63.25	BB-320750SX	64.15
.320	.3200	.3400	.900	.080	.1325	.3750	2.5	BB-320900S	55.55				
.320	.3200	.3400	1.000	.080	.1325	.3750	2.5	BB-3201000S	55.55	BB-3201000SG	63.25	BB-3201000SX	64.15
.320	.3200	.3400	1.100	.080	.1325	.3750	2.5	BB-3201100S	55.55	BB-3201100SG	63.25		
.320	.3200	.3400	1.250	.080	.1325	.3750	2.5	BB-3201250S	55.55	BB-3201250SG	63.25	BB-3201250SX	64.15
.320	.3200	.3400	1.500	.080	.1325	.3750	2.5	BB-3201500S	55.55	BB-3201500SG	63.25	BB-3201500SX	64.15
.320	.3200	.3400	1.600	.080	.1325	.3750	2.5	BB-3201600S	55.55	BB-3201600SG	63.25	BB-3201600SX	64.15
.320	.3200	.3400	1.800	.080	.1325	.3750	2.5	BB-3201800S	55.55	BB-3201800SG	63.25	BB-3201800SX	64.15
.320	.3200	.3400	2.000	.080	.1325	.3750	4.0	BB-3202000S	71.35	BB-3202000SG	80.60	BB-3202000SX	80.60
.320	.3200	.3400	2.500	.080	.1325	.3750	4.0	BB-3202500S	71.35	BB-3202500SG	80.60	BB-3202500SX	80.60
.320	.3200	.3400	3.000	.080	.1325	.3750	4.0	BB-3203000S	71.35	BB-3203000SG	80.60	BB-3203000SX	80.60
9 mm	.3543	9.5 mm	25 mm	2.25 mm	4mm	10 mm	72 mm	BBM-100925	58.00	BBM-100925G	65.85		
9 mm	.3543	9.5 mm	32 mm	2.25 mm	4mm	10 mm	72 mm	BBM-100932	58.00	BBM-100932G	65.85		
9 mm	.3543	9.5 mm	38 mm	2.25 mm	4mm	10 mm	72 mm	BBM-100938	58.00	BBM-100938G	65.85		
9 mm	.3543	9.5 mm	46 mm	2.25 mm	4mm	10 mm	72 mm	BBM-100946	58.00	BBM-100946G	65.85		
9 mm	.3543	9.5 mm	50 mm	2.25 mm	4mm	10 mm	72 mm	BBM-100950	58.00				
.360	.3600	.3800	.500	.090	.1725	.3750	2.5	BB-360500S	55.55	BB-360500SG	63.25	BB-360500SX	64.15
.360	.3600	.3800	.600	.090	.1725	.3750	2.5	BB-360600S	55.55	BB-360600SG	63.25	BB-360600SX	64.15
.360	.3600	.3800	.750	.090	.1725	.3750	2.5	BB-360750S	55.55	BB-360750SG	63.25	BB-360750SX	64.15
.360	.3600	.3800	.900	.090	.1725	.3750	2.5	BB-360900S	55.55	BB-360900SG	63.25	BB-360900SX	64.15
.360	.3600	.3800	1.000	.090	.1725	.3750	2.5	BB-3601000S	55.55	BB-3601000SG	63.25	BB-3601000SX	64.15
.360	.3600	.3800	1.150	.090	.1725	.3750	2.5	BB-3601150S	55.55	BB-3601150SG	63.25	BB-3601150SX	64.15
.360	.3600	.3800	1.250	.090	.1725	.3750	2.5	BB-3601250S	55.55	BB-3601250SG	63.25	BB-3601250SX	64.15
.360	.3600	.3800	1.500	.090	.1725	.3750	2.5	BB-3601500S	55.55	BB-3601500SG	63.25	BB-3601500SX	64.15
.360	.3600	.3800	1.600	.090	.1725	.3750	2.5	BB-3601600S	55.55	BB-3601600SG	63.25	BB-3601600SX	64.15
.360	.3600	.3800	1.800	.090	.1725	.3750	2.5	BB-3601800S	55.55	BB-3601800SG	63.25	BB-3601800SX	64.15
.360	.3600	.3800	2.000	.090	.1725	.3750	4.0	BB-3602000S	71.35	BB-3602000SG	80.60	BB-3602000SX	80.60
.360	.3600	.3800	2.500	.090	.1725	.3750	4.0	BB-3602500S	71.35	BB-3602500SG	80.60	BB-3602500SX	80.60
.360	.3600	.3800	3.000	.090	.1725	.3750	4.0	BB-3603000S	71.35			BB-3603000SX	80.60
10 mm	.3937	10.5 mm	15 mm	2.50 mm	5 mm	10 mm	72 mm	BBM-101015	58.00	BBM-101015G	65.85		
10 mm	.3937	10.5 mm	20 mm	2.50 mm	5 mm	10 mm	72 mm	BBM-101020	58.00	BBM-101020G	65.85		
10 mm	.3937	10.5 mm	25 mm	2.50 mm	5 mm	10 mm	72 mm	BBM-101025	58.00	BBM-101025G	65.85	BBM-101025X	67.85
10 mm	.3937	10.5 mm	32 mm	2.50 mm	5 mm	10 mm	72 mm	BBM-101032	58.00	BBM-101032G	65.85		
10 mm	.3937	10.5 mm	38 mm	2.50 mm	5 mm	10 mm	72 mm	BBM-101038	58.00	BBM-101038G	65.85		
10 mm	.3937	10.5 mm	50 mm	2.50 mm	5 mm	10 mm	72 mm	BBM-101050	58.00	BBM-101050G	65.85	BBM-101050X	67.85
11 mm	.4331	11.5 mm	15 mm	2.75 mm	5 mm	12 mm	83 mm	BBM-121115	73.10				
11 mm	.4331	11.5 mm	38 mm	2.75 mm	5 mm	12 mm	83 mm	BBM-121138	73.10				
11 mm	.4331	11.5 mm	50 mm	2.75 mm	5 mm	12 mm	83 mm	BBM-121150	73.10	BBM-121150G	83.85		
12 mm	.4724	12.5 mm	20 mm	3 mm	6 mm	12 mm	83 mm	BBM-121220	73.10				
12 mm	.4724	12.5 mm	32 mm	3 mm	6 mm	12 mm	83 mm	BBM-121232	73.10	BBM-121232G	83.85	BBM-121232X	85.65
12 mm	.4724	12.5 mm	46 mm	3 mm	6 mm	12 mm	83 mm	BBM-121246	73.10	BBM-121246G	83.85		
12 mm	.4724	12.5 mm	60 mm	3 mm	6 mm	12 mm	83 mm	BBM-121260	73.10	BBM-121260G	83.85		

Standard – Boring Tools

*Suggested Minimum Bore Diameter to accommodate chip evacuation and retract clearance in static (not live) applications.

Continued on next page

Standard – Boring Tools

Right Hand – Sharp (cont.)

BBS / BBM

Continued from previous page

Head Width		Min. Bore Dia*	Max. Bore Depth	Projection	Centerline Offset	Shank Dia.	OAL	Uncoated		TiN Coated		AlTiN Coated	
H	decimal equiv.	L2	$+0.050''$ $-0.000''$ $+1.24mm$ $-0.00mm$	P	F	D2 (h6)	L1	Tool #	Price	Tool #	Price	Tool #	Price
.490	.4900	.5100	.750	.122	.2400	.5000	3.0	BB-490750S	78.00	BB-490750SG	87.50	BB-490750SX	89.70
.490	.4900	.5100	1.000	.122	.2400	.5000	3.0	BB-4901000S	78.00			BB-4901000SX	89.70
.490	.4900	.5100	1.250	.122	.2400	.5000	3.0	BB-4901250S	78.00			BB-4901250SX	89.70
.490	.4900	.5100	1.500	.122	.2400	.5000	3.0	BB-4901500S	78.00			BB-4901500SX	89.70
.490	.4900	.5100	2.000	.122	.2400	.5000	4.0	BB-4902000S	85.55	BB-4902000SG	96.75	BB-4902000SX	98.10
.490	.4900	.5100	2.500	.122	.2400	.5000	4.0	BB-4902500S	85.55	BB-4902500SG	96.75	BB-4902500SX	98.10
.490	.4900	.5100	2.750	.122	.2400	.5000	4.0	BB-4902750S	85.55	BB-4902750SG	96.75	BB-4902750SX	98.10
.490	.4900	.5100	3.000	.122	.2400	.5000	6.0	BB-4903000S	107.95				
.490	.4900	.5100	3.500	.122	.2400	.5000	6.0	BB-4903500S	107.95	BB-4903500SG	122.50	BB-4903500SX	122.55
.490	.4900	.5100	4.000	.122	.2400	.5000	6.0	BB-4904000S	107.95			BB-4904000SX	122.55
.490	.4900	.5100	4.500	.122	.2400	.5000	6.0	BB-4904500S	107.95			BB-4904500SX	122.55

*Suggested Minimum Bore Diameter to accommodate chip evacuation and retract clearance in static (not live) applications.

Standard – Boring Tools

Technical Resources on Micro100.com

Find Simulation Files, Speeds & Feeds, Torque Recommendations, Programs, Blogs, and more at [micro100.com/resources](https://Micro100.com/resources)



BB

Standard – Boring Tools

Right Hand

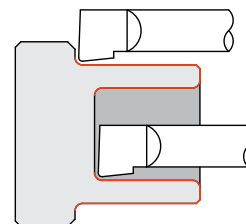
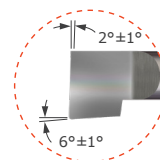
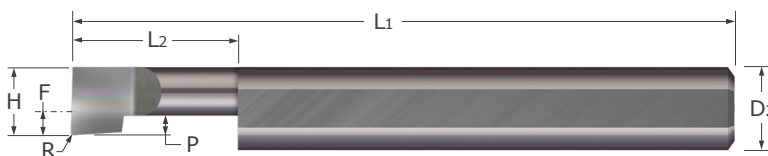

- Designed for facing and boring applications in bores .055" and larger
- Polished split face for improved edge retention and chip evacuation while reducing galling
- Split face geometry provides optimal edge strength
- Corner radius profile
- Lockdown flat automatically locates tool on center
- Coating options provide added lubricity and increased wear resistance in difficult to machine materials
- Solid carbide ■ CNC ground in the USA

Head Width	Minimum Bore Dia.*	Max. Bore Depth	Radius	Projection	Centerline Offset	Shank Dia.	OAL	Uncoated		TiN Coated		AlTiN Coated	
H	L2	$^{+.050}_{-.000}$ "	$^{+.003}_{-.000}$ "	P	F	D2 (h6)	L1	Tool #	Price	Tool #	Price	Tool #	Price
.050	.055	.150	.003	.012	-.0125	.1250	1.5	BB-050150	27.15	BB-050150G	30.30	BB-050150X	31.00
.050	.055	.200	.003	.012	-.0125	.1250	1.5	BB-050200	27.15	BB-050200G	30.30	BB-050200X	31.00
.050	.055	.300	.003	.012	-.0125	.1250	1.5	BB-050300	27.15	BB-050300G	30.30	BB-050300X	31.00
.050	.055	.400	.003	.012	-.0125	.1250	1.5	BB-050400	27.15	BB-050400G	30.30	BB-050400X	31.00
.060	.070	.150	.003	.015	-.0025	.1250	1.5	BB-060150	27.15	BB-060150G	30.30	BB-060150X	31.00
.060	.070	.200	.003	.015	-.0025	.1250	1.5	BB-060200	27.15	BB-060200G	30.30	BB-060200X	31.00
.060	.070	.300	.003	.015	-.0025	.1250	1.5	BB-060300	27.15	BB-060300G	30.30	BB-060300X	31.00
.060	.070	.400	.003	.015	-.0025	.1250	1.5	BB-060400	27.15	BB-060400G	30.30	BB-060400X	31.00
.060	.070	.500	.003	.015	-.0025	.1250	1.5	BB-060500	27.15	BB-060500G	30.30	BB-060500X	31.00
.070	.080	.150	.003	.015	.0075	.1250	1.5	BB-070150	27.15			BB-070150X	31.00
.070	.080	.200	.003	.015	.0075	.1250	1.5	BB-070200	27.15			BB-070200X	31.00
.070	.080	.300	.003	.015	.0075	.1250	1.5	BB-070300	27.15			BB-070300X	31.00
.080	.090	.150	.003	.020	.0175	.1250	1.5	BB-080150	27.15	BB-080150G	30.30	BB-080150X	31.00
.080	.090	.200	.003	.020	.0175	.1250	1.5	BB-080200	27.15	BB-080200G	30.30	BB-080200X	31.00
.080	.090	.300	.003	.020	.0175	.1250	1.5	BB-080300	27.15	BB-080300G	30.30	BB-080300X	31.00
.080	.090	.400	.003	.020	.0175	.1250	1.5	BB-080400	27.15	BB-080400G	30.30	BB-080400X	31.00
.080	.090	.500	.003	.020	.0175	.1250	1.5	BB-080500	27.15	BB-080500G	30.30	BB-080500X	31.00
.080	.090	.600	.003	.020	.0175	.1250	1.5	BB-080600	27.15	BB-080600G	30.30	BB-080600X	31.00
.090	.100	.150	.003	.020	.0275	.1250	1.5	BB3-090150	27.15	BB3-090150G	31.35	BB3-090150X	31.35
.090	.100	.200	.003	.020	.0275	.1250	1.5	BB3-090200	27.15	BB3-090200G	31.35	BB3-090200X	31.35
.090	.100	.300	.003	.020	.0275	.1250	1.5	BB-090300	27.15			BB-090300X	31.00
.090	.100	.400	.003	.020	.0275	.1250	1.5	BB3-090400	27.15	BB3-090400G	31.35	BB3-090400X	31.35
.090	.100	.500	.003	.020	.0275	.1250	1.5	BB3-090500	27.15	BB3-090500G	31.35	BB3-090500X	31.35

*Suggested Minimum Bore Diameter to accommodate chip evacuation and retract clearance in static (not live) applications.

Continued on next page



Standard – Boring Tools

BB

Right Hand (cont.)

Continued from previous page

Head Width	Minimum Bore Dia.*	Max. Bore Depth	Radius	Projection	Centerline Offset	Shank Dia.	OAL	Uncoated		TIN Coated		ATIN Coated		
								Tool #	Price	Tool #	Price	Tool #	Price	
H	L2	$\begin{matrix} +.050'' \\ -.000'' \end{matrix}$	$\begin{matrix} +.003'' \\ -.000'' \end{matrix}$	R	P	F	D2 (h6)	L1	Tool #	Price	Tool #	Price	Tool #	Price
.100	.110	.150	.003	.025	.0375	.1250	1.5	BB-100150	27.15	BB-100150G	30.30	BB-100150X	31.00	
.100	.110	.200	.003	.025	.0375	.1250	1.5	BB-100200	27.15	BB-100200G	30.30	BB-100200X	31.00	
.100	.110	.300	.003	.025	.0375	.1250	1.5	BB-100300	27.15	BB-100300G	30.30	BB-100300X	31.00	
.100	.110	.400	.003	.025	.0375	.1250	1.5	BB-100400	27.15	BB-100400G	30.30	BB-100400X	31.00	
.100	.110	.500	.003	.025	.0375	.1250	1.5	BB-100500	27.15	BB-100500G	30.30	BB-100500X	31.00	
.100	.110	.600	.003	.025	.0375	.1250	1.5	BB-100600	27.15	BB-100600G	30.30	BB-100600X	31.00	
.100	.110	.700	.003	.025	.0375	.1250	1.5	BB-100700	27.15	BB-100700G	30.30	BB-100700X	31.00	
.110	.122	.150	.003	.027	.0475	.1250	1.5	BB-110150	27.15	BB-110150G	30.30	BB-110150X	31.00	
.110	.122	.200	.003	.027	.0475	.1250	1.5	BB-110200	27.15	BB-110200G	30.30	BB-110200X	31.00	
.110	.122	.300	.003	.027	.0475	.1250	1.5	BB-110300	27.15	BB-110300G	30.30	BB-110300X	31.00	
.110	.122	.400	.003	.027	.0475	.1250	1.5	BB-110400	27.15	BB-110400G	30.30	BB-110400X	31.00	
.110	.122	.500	.003	.027	.0475	.1250	1.5	BB-110500	27.15	BB-110500G	30.30	BB-110500X	31.00	
.110	.122	.600	.003	.027	.0475	.1250	1.5	BB-110600	27.15	BB-110600G	30.30	BB-110600X	31.00	
.110	.122	.700	.003	.027	.0475	.1250	1.5	BB-110700	27.15	BB-110700G	30.30	BB-110700X	31.00	

H	L2	$\begin{matrix} +.050'' \\ -.000'' \end{matrix}$	$\begin{matrix} +.003'' \\ -.000'' \end{matrix}$	R	P	F	D2 (h6)	L1	Uncoated		TIN Coated		ATIN Coated	
									Tool #	Price	Tool #	Price	Tool #	Price
.120	.132	.250	.003	.030	.0263	.1875	2.0	BB3-120250	28.80	BB3-120250G	33.55	BB3-120250X	33.55	
.120	.132	.250	.006	.030	.0263	.1875	2.0	BB-120250	28.80	BB-120250G	32.35	BB-120250X	33.20	
.120	.132	.350	.003	.030	.0263	.1875	2.0	BB3-120350	28.80	BB3-120350G	33.55	BB3-120350X	33.55	
.120	.132	.350	.006	.030	.0263	.1875	2.0	BB-120350	28.80	BB-120350G	32.35	BB-120350X	33.20	
.120	.132	.500	.003	.030	.0263	.1875	2.0	BB3-120500	28.80	BB3-120500G	33.55	BB3-120500X	33.55	
.120	.132	.500	.006	.030	.0263	.1875	2.0	BB-120500	28.80	BB-120500G	32.35	BB-120500X	33.20	
.120	.132	.600	.003	.030	.0263	.1875	2.0	BB3-120600	28.80	BB3-120600G	33.55	BB3-120600X	33.55	
.120	.132	.600	.006	.030	.0263	.1875	2.0	BB-120600	28.80	BB-120600G	32.35	BB-120600X	33.20	
.120	.132	.700	.003	.030	.0263	.1875	2.0	BB3-120700	28.80	BB3-120700G	33.55	BB3-120700X	33.55	
.120	.132	.700	.006	.030	.0263	.1875	2.0	BB-120700	28.80	BB-120700G	32.35	BB-120700X	33.20	
.120	.132	.800	.003	.030	.0263	.1875	2.0	BB3-120800	28.80	BB3-120800G	33.55	BB3-120800X	33.55	
.120	.132	.800	.006	.030	.0263	.1875	2.0	BB-120800	28.80	BB-120800G	32.35	BB-120800X	33.20	
.140	.152	.250	.003	.035	.0463	.1875	2.0	BB3-140250	28.80	BB3-140250G	33.55	BB3-140250X	33.55	
.140	.152	.250	.006	.035	.0463	.1875	2.0	BB-140250	28.80	BB-140250G	32.35	BB-140250X	33.20	
.140	.152	.400	.003	.035	.0463	.1875	2.0	BB3-140400	28.80	BB3-140400G	33.55	BB3-140400X	33.55	
.140	.152	.400	.006	.035	.0463	.1875	2.0	BB-140400	28.80	BB-140400G	32.35	BB-140400X	33.20	
.140	.152	.500	.003	.035	.0463	.1875	2.0	BB3-140500	28.80	BB3-140500G	33.55	BB3-140500X	33.55	
.140	.152	.500	.006	.035	.0463	.1875	2.0	BB-140500	28.80	BB-140500G	32.35	BB-140500X	33.20	
.140	.152	.600	.003	.035	.0463	.1875	2.0	BB3-140600	28.80	BB3-140600G	33.55	BB3-140600X	33.55	
.140	.152	.600	.006	.035	.0463	.1875	2.0	BB-140600	28.80	BB-140600G	32.35	BB-140600X	33.20	
.140	.152	.700	.003	.035	.0463	.1875	2.0	BB3-140700	28.80	BB3-140700G	33.55	BB3-140700X	33.55	
.140	.152	.700	.006	.035	.0463	.1875	2.0	BB-140700	28.80	BB-140700G	32.35	BB-140700X	33.20	
.140	.152	.750	.003	.035	.0463	.1875	2.0	BB3-140750	28.80	BB3-140750G	33.55	BB3-140750X	33.55	
.140	.152	.750	.006	.035	.0463	.1875	2.0	BB-140750	28.80	BB-140750G	32.35	BB-140750X	33.20	
.140	.152	.800	.003	.035	.0463	.1875	2.0	BB3-140800	28.80	BB3-140800G	33.55	BB3-140800X	33.55	
.140	.152	.800	.006	.035	.0463	.1875	2.0	BB-140800	28.80	BB-140800G	32.35	BB-140800X	33.20	
.140	.152	.900	.003	.035	.0463	.1875	2.0	BB3-140900	28.80	BB3-140900G	33.55	BB3-140900X	33.55	
.140	.152	.900	.006	.035	.0463	.1875	2.0	BB6-140900	28.80	BB6-140900G	33.55	BB6-140900X	33.55	

*Suggested Minimum Bore Diameter to accommodate chip evacuation and retract clearance in static (not live) applications.

Continued on next page

Standard – Boring Tools

BB

Standard – Boring Tools

Right Hand (cont.)

Continued from previous page

Head Width	Minimum Bore Dia.*	Max. Bore Depth	Radius	Projection	Centerline Offset	Shank Dia.	OAL	Uncoated		TiN Coated		AlTiN Coated	
								Tool #	Price	Tool #	Price	Tool #	Price
H	L2	$^{+.050"}_{-.000"}$	$R^{+.002"}_{-.000"}$	P	F	D2 (h6)	L1	Tool #	Price	Tool #	Price	Tool #	Price
.160	.176	.250	.003	.040	.0663	.1875	2.0	BB3-160250	28.80	BB3-160250G	33.55	BB3-160250X	33.55
.160	.176	.250	.006	.040	.0663	.1875	2.0	BB-160250	28.80	BB-160250G	32.35	BB-160250X	33.20
.160	.176	.400	.003	.040	.0663	.1875	2.0	BB3-160400	28.80	BB3-160400G	33.55	BB3-160400X	33.55
.160	.176	.400	.006	.040	.0663	.1875	2.0	BB-160400	28.80	BB-160400G	32.35	BB-160400X	33.20
.160	.176	.500	.003	.040	.0663	.1875	2.0	BB3-160500	28.80	BB3-160500G	33.55	BB3-160500X	33.55
.160	.176	.500	.006	.040	.0663	.1875	2.0	BB-160500	28.80	BB-160500G	32.35	BB-160500X	33.20
.160	.176	.600	.003	.040	.0663	.1875	2.0	BB3-160600	28.80	BB3-160600G	33.55	BB3-160600X	33.55
.160	.176	.600	.006	.040	.0663	.1875	2.0	BB-160600	28.80	BB-160600G	32.35	BB-160600X	33.20
.160	.176	.700	.003	.040	.0663	.1875	2.0	BB3-160700	28.80	BB3-160700G	33.55	BB3-160700X	33.55
.160	.176	.700	.006	.040	.0663	.1875	2.0	BB6-160700	28.80	BB6-160700G	33.55	BB6-160700X	33.55
.160	.176	.750	.003	.040	.0663	.1875	2.0	BB3-160750	28.80	BB3-160750G	33.55	BB3-160750X	33.55
.160	.176	.750	.006	.040	.0663	.1875	2.0	BB-160750	28.80	BB-160750G	32.35	BB-160750X	33.20
.160	.176	.800	.003	.040	.0663	.1875	2.0	BB3-160800	28.80	BB3-160800G	33.55	BB3-160800X	33.55
.160	.176	.800	.006	.040	.0663	.1875	2.0	BB6-160800	28.80	BB6-160800G	33.55	BB6-160800X	33.55
.160	.176	.900	.003	.040	.0663	.1875	2.0	BB3-160900	28.80	BB3-160900G	33.55	BB3-160900X	33.55
.160	.176	.900	.006	.040	.0663	.1875	2.0	BB-160900	28.80	BB-160900G	32.35	BB-160900X	33.20
.160	.176	1.000	.003	.040	.0663	.1875	2.0	BB3-1601000	28.80	BB3-1601000G	33.55	BB3-1601000X	33.55
.160	.176	1.000	.006	.040	.0663	.1875	2.0	BB-1601000	28.80	BB-1601000G	32.35	BB-1601000X	33.20
.180	.196	.350	.006	.045	.0550	.2500	2.5	BB-180350	31.15	BB-180350G	36.10	BB-180350X	37.20
.180	.196	.500	.006	.045	.0550	.2500	2.5	BB-180500	31.15	BB-180500G	36.10	BB-180500X	37.20
.180	.196	.600	.006	.045	.0550	.2500	2.5	BB-180600	31.15	BB-180600G	36.10	BB-180600X	37.20
.180	.196	.750	.006	.045	.0550	.2500	2.5	BB-180750	31.15	BB-180750G	36.10	BB-180750X	37.20
.180	.196	.900	.006	.045	.0550	.2500	2.5	BB-180900	31.15	BB-180900G	36.10	BB-180900X	37.20
.180	.196	1.000	.006	.045	.0550	.2500	2.5	BB-1801000	31.15	BB-1801000G	36.10	BB-1801000X	37.20
.180	.196	1.100	.006	.045	.0550	.2500	2.5	BB-1801100	31.15	BB-1801100G	36.10	BB-1801100X	37.20
.180	.196	1.250	.006	.045	.0550	.2500	2.5	BB-1801250	31.15	BB-1801250G	36.10	BB-1801250X	37.20
.180	.196	1.500	.006	.045	.0550	.2500	2.5	BB-1801500	31.15	BB-1801500G	36.10	BB-1801500X	37.20
.200	.216	.400	.006	.050	.0750	.2500	2.5	BB-200400	31.15	BB-200400G	36.10	BB-200400X	37.20
.200	.216	.500	.006	.050	.0750	.2500	2.5	BB-200500	31.15	BB-200500G	36.10	BB-200500X	37.20
.200	.216	.600	.006	.050	.0750	.2500	2.5	BB-200600	31.15	BB-200600G	36.10	BB-200600X	37.20
.200	.216	.700	.006	.050	.0750	.2500	2.5	BB-200700	31.15	BB-200700G	36.10	BB-200700X	37.20
.200	.216	.750	.006	.050	.0750	.2500	2.5	BB6-200750	31.15	BB6-200750G	37.20	BB6-200750X	37.20
.200	.216	.800	.006	.050	.0750	.2500	2.5	BB-200800	31.15	BB-200800G	36.10	BB-200800X	37.20
.200	.216	.900	.006	.050	.0750	.2500	2.5	BB-200900	31.15	BB-200900G	36.10	BB-200900X	37.20
.200	.216	1.000	.006	.050	.0750	.2500	2.5	BB-2001000	31.15	BB-2001000G	36.10	BB-2001000X	37.20
.200	.216	1.100	.006	.050	.0750	.2500	2.5	BB-2001100	31.15			BB-2001100X	37.20
.200	.216	1.200	.006	.050	.0750	.2500	2.5	BB-2001200	31.15	BB-2001200G	36.10	BB-2001200X	37.20
.200	.216	1.300	.006	.050	.0750	.2500	2.5	BB-2001300	31.15	BB-2001300G	36.10	BB-2001300X	37.20
.200	.216	1.500	.006	.050	.0750	.2500	2.5	BB6-2001500	31.15	BB6-2001500G	37.20	BB6-2001500X	37.20

*Suggested Minimum Bore Diameter to accommodate chip evacuation and retract clearance in static (not live) applications.

Continued on next page

Standard – Boring Tools

Standard – Boring Tools

BB

Right Hand (cont.)

Continued from previous page

Head Width	Minimum Bore Dia.*	Max. Bore Depth	Radius	Projection	Centerline Offset	Shank Dia.	OAL	Uncoated		TIN Coated		AlTiN Coated	
								Tool #	Price	Tool #	Price	Tool #	Price
H	L ₂	+ .050" - .000"	R	P	F	D ₂ (h6)	L ₁						
.230	.250	.400	.006	.057	.0738	.3125	2.5	BB-230400	41.80	BB-230400G	48.90	BB-230400X	49.05
.230	.250	.500	.006	.057	.0738	.3125	2.5	BB-230500	41.80	BB-230500G	48.90	BB-230500X	49.05
.230	.250	.600	.006	.057	.0738	.3125	2.5	BB-230600	41.80	BB-230600G	48.90	BB-230600X	49.05
.230	.250	.700	.006	.057	.0738	.3125	2.5	BB-230700	41.80	BB-230700G	48.90	BB-230700X	49.05
.230	.250	.750	.006	.057	.0738	.3125	2.5	BB6-230750	41.80	BB6-230750G	49.05	BB6-230750X	49.05
.230	.250	.800	.006	.057	.0738	.3125	2.5	BB-230800	41.80	BB-230800G	48.90	BB-230800X	49.05
.230	.250	.900	.006	.057	.0738	.3125	2.5	BB-230900	41.80	BB-230900G	48.90	BB-230900X	49.05
.230	.250	1.000	.006	.057	.0738	.3125	2.5	BB-2301000	41.80	BB-2301000G	48.90	BB-2301000X	49.05
.230	.250	1.100	.006	.057	.0738	.3125	2.5	BB-2301100	41.80	BB-2301100G	48.90	BB-2301100X	49.05
.230	.250	1.150	.006	.057	.0738	.3125	2.5	BB-2301150	41.80	BB-2301150G	48.90	BB-2301150X	49.05
.230	.250	1.200	.006	.057	.0738	.3125	2.5	BB-2301200	41.80	BB-2301200G	48.90	BB-2301200X	49.05
.230	.250	1.250	.006	.057	.0738	.3125	2.5	BB-2301250	41.80	BB-2301250G	48.90	BB-2301250X	49.05
.230	.250	1.400	.006	.057	.0738	.3125	2.5	BB-2301400	41.80	BB-2301400G	48.90	BB-2301400X	49.05
.230	.250	1.500	.006	.057	.0738	.3125	2.5	BB-2301500	41.80	BB-2301500G	48.90	BB-2301500X	49.05
.230	.250	1.600	.006	.057	.0738	.3125	2.5	BB-2301600	41.80	BB-2301600G	48.90	BB-2301600X	49.05
.260	.280	.400	.006	.065	.1038	.3125	2.5	BB6-260400	41.80	BB6-260400G	49.05	BB6-260400X	49.05
.260	.280	.500	.006	.065	.1038	.3125	2.5	BB6-260500	41.80	BB6-260500G	49.05	BB6-260500X	49.05
.260	.280	.600	.006	.065	.1038	.3125	2.5	BB6-260600	41.80	BB6-260600G	49.05	BB6-260600X	49.05
.260	.280	.700	.006	.065	.1038	.3125	2.5	BB6-260700	41.80	BB6-260700G	49.05	BB6-260700X	49.05
.260	.280	.750	.006	.065	.1038	.3125	2.5	BB6-260750	41.80	BB6-260750G	49.05	BB6-260750X	49.05
.260	.280	.800	.006	.065	.1038	.3125	2.5	BB6-260800	41.80	BB6-260800G	49.05	BB6-260800X	49.05
.260	.280	.900	.006	.065	.1038	.3125	2.5	BB6-260900	41.80	BB6-260900G	49.05	BB6-260900X	49.05
.260	.280	1.000	.006	.065	.1038	.3125	2.5	BB6-2601000	41.80	BB6-2601000G	49.05	BB6-2601000X	49.05
.260	.280	1.250	.006	.065	.1038	.3125	2.5	BB6-2601250	41.80	BB6-2601250G	49.05	BB6-2601250X	49.05
.290	.310	.500	.006	.072	.1338	.3125	2.5	BB-290500	41.80	BB-290500G	48.90	BB-290500X	49.05
.290	.310	.600	.006	.072	.1338	.3125	2.5	BB-290600	41.80	BB-290600G	48.90	BB-290600X	49.05
.290	.310	.750	.006	.072	.1338	.3125	2.5	BB-290750	41.80	BB-290750G	48.90	BB-290750X	49.05
.290	.310	.900	.006	.072	.1338	.3125	2.5	BB-290900	41.80	BB-290900G	48.90	BB-290900X	49.05
.290	.310	1.000	.006	.072	.1338	.3125	2.5	BB-2901000	41.80	BB-2901000G	48.90	BB-2901000X	49.05
.290	.310	1.100	.006	.072	.1338	.3125	2.5	BB-2901100	41.80	BB-2901100G	48.90	BB-2901100X	49.05
.290	.310	1.250	.006	.072	.1338	.3125	2.5	BB-2901250	41.80	BB-2901250G	48.90	BB-2901250X	49.05
.290	.310	1.350	.006	.072	.1338	.3125	2.5	BB-2901350	41.80	BB-2901350G	48.90	BB-2901350X	49.05
.290	.310	1.500	.006	.072	.1338	.3125	2.5	BB-2901500	41.80	BB-2901500G	48.90	BB-2901500X	49.05
.290	.310	1.600	.006	.072	.1338	.3125	2.5	BB-2901600	41.80	BB-2901600G	48.90	BB-2901600X	49.05
.290	.310	1.750	.006	.072	.1338	.3125	2.5	BB-2901750	41.80	BB-2901750G	48.90	BB-2901750X	49.05
.320	.340	.500	.006	.080	.1325	.3750	2.5	BB-320500	57.05	BB-320500G	64.75	BB-320500X	65.65
.320	.340	.600	.006	.080	.1325	.3750	2.5	BB-320600	57.05	BB-320600G	64.75	BB-320600X	65.65
.320	.340	.750	.006	.080	.1325	.3750	2.5	BB-320750	57.05	BB-320750G	64.75	BB-320750X	65.65
.320	.340	.900	.006	.080	.1325	.3750	2.5	BB-320900	57.05	BB-320900G	64.75	BB-320900X	65.65
.320	.340	1.000	.006	.080	.1325	.3750	2.5	BB-3201000	57.05	BB-3201000G	64.75	BB-3201000X	65.65
.320	.340	1.100	.006	.080	.1325	.3750	2.5	BB-3201100	57.05	BB-3201100G	64.75	BB-3201100X	65.65
.320	.340	1.250	.006	.080	.1325	.3750	2.5	BB-3201250	57.05	BB-3201250G	64.75	BB-3201250X	65.65
.320	.340	1.500	.006	.080	.1325	.3750	2.5	BB-3201500	57.05	BB-3201500G	64.75	BB-3201500X	65.65

*Suggested Minimum Bore Diameter to accommodate chip evacuation and retract clearance in static (not live) applications.

Continued on next page

Standard – Boring Tools

BB

Standard – Boring Tools
Right Hand (cont.)

Continued from previous page

Head Width	Minimum Bore Dia.*	Max. Bore Depth	Radius	Projection	Centerline Offset	Shank Dia.	OAL	Uncoated		TIN Coated		AlTiN Coated	
								Tool #	Price	Tool #	Price	Tool #	Price
H	L ₂ ^{+0.050"} _{-.000"}	R ^{+0.002"} _{-.000"}	P	F	D ₂ (h6)	L ₁							
.320	.340	1.600	.006	.080	.1325	.3750	2.5	BB-3201600	57.05	BB-3201600G	64.75	BB-3201600X	65.65
.320	.340	1.800	.006	.080	.1325	.3750	2.5	BB-3201800	57.05	BB-3201800G	64.75	BB-3201800X	65.65
.320	.340	2.000	.006	.080	.1325	.3750	4.0	BB-3202000	72.95	BB-3202000G	82.20	BB-3202000X	82.20
.320	.340	2.500	.006	.080	.1325	.3750	4.0	BB-3202500	72.95	BB-3202500G	82.20	BB-3202500X	82.20
.320	.340	3.000	.006	.080	.1325	.3750	4.0	BB-3203000	72.95			BB-3203000X	82.20
.360	.380	.500	.006	.090	.1725	.3750	2.5	BB-360500	57.05	BB-360500G	64.75	BB-360500X	65.65
.360	.380	.600	.006	.090	.1725	.3750	2.5	BB-360600	57.05	BB-360600G	64.75	BB-360600X	65.65
.360	.380	.750	.006	.090	.1725	.3750	2.5	BB-360750	57.05	BB-360750G	64.75	BB-360750X	65.65
.360	.380	.900	.006	.090	.1725	.3750	2.5	BB-360900	57.05	BB-360900G	64.75	BB-360900X	65.65
.360	.380	1.000	.006	.090	.1725	.3750	2.5	BB-3601000	57.05	BB-3601000G	64.75	BB-3601000X	65.65
.360	.380	1.150	.006	.090	.1725	.3750	2.5	BB-3601150	57.05	BB-3601150G	64.75	BB-3601150X	65.65
.360	.380	1.250	.006	.090	.1725	.3750	2.5	BB-3601250	57.05	BB-3601250G	64.75	BB-3601250X	65.65
.360	.380	1.500	.006	.090	.1725	.3750	2.5	BB-3601500	57.05	BB-3601500G	64.75	BB-3601500X	65.65
.360	.380	1.600	.006	.090	.1725	.3750	2.5	BB-3601600	57.05	BB-3601600G	64.75	BB-3601600X	65.65
.360	.380	1.800	.006	.090	.1725	.3750	2.5	BB-3601800	57.05	BB-3601800G	64.75	BB-3601800X	65.65
.360	.380	2.000	.006	.090	.1725	.3750	4.0	BB-3602000	72.95	BB-3602000G	82.20	BB-3602000X	82.20
.360	.380	2.500	.006	.090	.1725	.3750	4.0	BB-3602500	72.95	BB-3602500G	82.20	BB-3602500X	82.20
.360	.380	3.000	.006	.090	.1725	.3750	4.0	BB-3603000	72.95	BB-3603000G	82.20	BB-3603000X	82.20
.410	.430	.750	.006	.104	.1600	.5000	3.0	BB6-410750	79.50	BB6-410750G	91.20	BB6-410750X	91.20
.410	.430	1.000	.006	.104	.1600	.5000	3.0	BB6-4101000	79.50	BB6-4101000G	91.20	BB6-4101000X	91.20
.410	.430	1.250	.006	.104	.1600	.5000	3.0	BB6-4101250	79.50	BB6-4101250G	91.20	BB6-4101250X	91.20
.410	.430	1.500	.006	.104	.1600	.5000	3.0	BB6-4101500	79.50	BB6-4101500G	91.20	BB6-4101500X	91.20
.460	.480	1.000	.006	.115	.2100	.5000	3.0	BB6-4601000	79.50	BB6-4601000G	91.20	BB6-4601000X	91.20
.460	.480	1.500	.006	.115	.2100	.5000	3.0	BB6-4601500	79.50	BB6-4601500G	91.20	BB6-4601500X	91.20
.460	.480	2.000	.006	.115	.2100	.5000	3.0	BB6-4602000	79.50	BB6-4602000G	91.20	BB6-4602000X	91.20
.490	.510	.750	.006	.122	.2400	.5000	3.0	BB-490750	79.50	BB-490750G	89.10	BB-490750X	91.20
.490	.510	1.000	.006	.122	.2400	.5000	3.0	BB-4901000	79.50	BB-4901000G	89.10	BB-4901000X	91.20
.490	.510	1.250	.006	.122	.2400	.5000	3.0	BB-4901250	79.50	BB-4901250G	89.10	BB-4901250X	91.20
.490	.510	1.500	.006	.122	.2400	.5000	3.0	BB-4901500	79.50	BB-4901500G	89.10	BB-4901500X	91.20
.490	.510	2.000	.006	.122	.2400	.5000	4.0	BB-4902000	87.15	BB-4902000G	98.40	BB-4902000X	99.70
.490	.510	2.500	.006	.122	.2400	.5000	4.0	BB-4902500	87.15	BB-4902500G	98.40	BB-4902500X	99.70
.490	.510	2.750	.006	.122	.2400	.5000	4.0	BB-4902750	87.15	BB-4902750G	98.40	BB-4902750X	99.70
.490	.510	3.000	.006	.122	.2400	.5000	6.0	BB-4903000	109.40	BB-4903000G	123.95	BB-4903000X	124.00
.490	.510	3.500	.006	.122	.2400	.5000	6.0	BB-4903500	109.40	BB-4903500G	123.95	BB-4903500X	124.00
.490	.510	4.000	.006	.122	.2400	.5000	6.0	BB-4904000	109.40			BB-4904000X	124.00
.490	.510	4.500	.006	.122	.2400	.5000	6.0	BB-4904500	109.40	BB-4904500G	123.95	BB-4904500X	124.00

*Suggested Minimum Bore Diameter to accommodate chip evacuation and retract clearance in static (not live) applications.

Standard – Boring Tools

Standard - Boring Tools

BBL

Left Hand

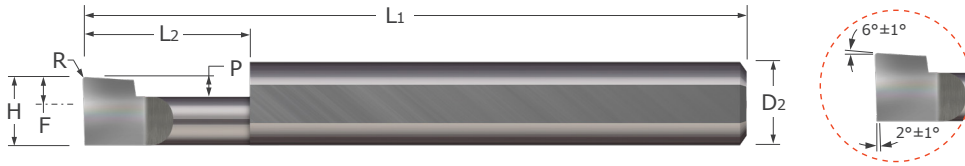

- Designed for left hand facing and boring applications
- Polished split face for improved edge retention and chip evacuation while reducing galling
- Split face geometry provides optimal edge strength
- Corner radius profile
- Lockdown flat automatically locates tool on center
- Coating options provide added lubricity and increased wear resistance in difficult to machine materials
- Solid carbide ■ CNC ground in the USA

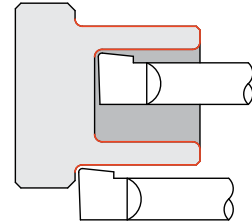

Standard - Boring Tools

Head Width	Minimum Bore Dia.*	Maximum Bore Depth	Radius	Projection	Centerline Offset	Shank Dia.	OAL	Uncoated		TIN Coated		AlTiN Coated	
								H	L2	Tool #	Price	Tool #	Price
			$R_{+.003"}^{-.000"}$	P	F	D2 (h6)	L1						
			$L2_{+.050"}^{-.000"}$										
.050	.055	.150	.003	.012	-.0125	.1250	1.5	BBL-050150	27.15	BBL-050150G	30.30	BBL-050150X	31.00
.050	.055	.200	.003	.012	-.0125	.1250	1.5	BBL-050200	27.15				
.050	.055	.400	.003	.012	-.0125	.1250	1.5	BBL-050400	27.15			BBL-050400X	31.00
.060	.070	.150	.003	.015	-.0025	.1250	1.5	BBL-060150	27.15				
.060	.070	.200	.003	.015	-.0025	.1250	1.5	BBL-060200	27.15			BBL-060200X	31.00
.060	.070	.300	.003	.015	-.0025	.1250	1.5	BBL-060300	27.15			BBL-060300X	31.00
.080	.090	.150	.003	.020	.0175	.1250	1.5			BBL-080150G	30.30		
.080	.090	.200	.003	.020	.0175	.1250	1.5	BBL-080200	27.15			BBL-080200X	31.00
.080	.090	.300	.003	.020	.0175	.1250	1.5	BBL-080300	27.15				
.080	.090	.400	.003	.020	.0175	.1250	1.5	BBL-080400	27.15	BBL-080400G	30.30	BBL-080400X	31.00
.080	.090	.500	.003	.020	.0175	.1250	1.5	BBL-080500	27.15	BBL-080500G	30.30	BBL-080500X	31.00
.100	.110	.150	.003	.025	.0375	.1250	1.5	BBL-100150	27.15				
.100	.110	.300	.003	.025	.0375	.1250	1.5	BBL-100300	27.15	BBL-100300G	30.30		
.100	.110	.500	.003	.025	.0375	.1250	1.5	BBL-100500	27.15	BBL-100500G	30.30	BBL-100500X	31.00
.100	.110	.600	.003	.025	.0375	.1250	1.5	BBL-100600	27.15				
.100	.110	.700	.003	.025	.0375	.1250	1.5	BBL-100700	27.15			BBL-100700X	31.00
.110	.122	.150	.003	.027	.0475	.1250	1.5	BBL-110150	27.15			BBL-110150X	31.00
.110	.122	.200	.003	.027	.0475	.1250	1.5			BBL-110200G	30.30		
.110	.122	.300	.003	.027	.0475	.1250	1.5	BBL-110300	27.15				
.110	.122	.400	.003	.027	.0475	.1250	1.5	BBL-110400	27.15			BBL-110400X	31.00
.110	.122	.600	.003	.027	.0475	.1250	1.5	BBL-110600	27.15			BBL-110600X	31.00
.110	.122	.700	.003	.027	.0475	.1250	1.5	BBL-110700	27.15			BBL-110700X	31.00

*Suggested Minimum Bore Diameter to accommodate chip evacuation and retract clearance in static (not live) applications.

Continued on next page

BBL

Standard – Boring Tools

Left Hand (cont.)

Continued from previous page

Head Width	Minimum Bore Dia.*	Maximum Bore Depth	Radius	Projection	Centerline Offset	Shank Dia.	OAL	Uncoated		TiN Coated		AlTiN Coated	
								Tool #	Price	Tool #	Price	Tool #	Price
H	L ₂	$^{+.050"}_{-.000"}$	R $^{+.002"}_{-.000"}$	P	F	D ₂ (h6)	L ₁	Tool #	Price	Tool #	Price	Tool #	Price
.120	.132	.250	.006	.030	.0263	.1875	2.0	BBL-120250	28.80			BBL-120250X	33.20
.120	.132	.500	.006	.030	.0263	.1875	2.0	BBL-120500	28.80			BBL-120500X	33.20
.120	.132	.600	.006	.030	.0263	.1875	2.0	BBL-120600	28.80			BBL-120600X	33.20
.120	.132	.700	.006	.030	.0263	.1875	2.0	BBL-120700	28.80			BBL-120700X	33.20
.140	.152	.250	.006	.035	.0463	.1875	2.0	BBL-140250	28.80	BBL-140250G	32.35	BBL-140250X	33.20
.140	.152	.400	.006	.035	.0463	.1875	2.0	BBL-140400	28.80			BBL-140400X	33.20
.140	.152	.500	.006	.035	.0463	.1875	2.0	BBL-140500	28.80			BBL-140500X	33.20
.140	.152	.600	.006	.035	.0463	.1875	2.0	BBL-140600	28.80				
.140	.152	.700	.006	.035	.0463	.1875	2.0	BBL-140700	28.80				
.140	.152	.800	.006	.035	.0463	.1875	2.0	BBL-140800	28.80				
.160	.176	.500	.006	.040	.0663	.1875	2.0	BBL-160500	28.80			BBL-160500X	33.20
.160	.176	.600	.006	.040	.0663	.1875	2.0	BBL-160600	28.80			BBL-160600X	33.20
.160	.176	.750	.006	.040	.0663	.1875	2.0	BBL-160750	28.80				
.160	.176	.900	.006	.040	.0663	.1875	2.0	BBL-160900	28.80	BBL-160900G	32.35	BBL-160900X	33.20
.160	.176	1.000	.006	.040	.0663	.1875	2.0	BBL-1601000	28.80			BBL-1601000X	33.20
.180	.196	.350	.006	.045	.0550	.2500	2.5	BBL-180350	31.15			BBL-180350X	37.20
.180	.196	.500	.006	.045	.0550	.2500	2.5	BBL-180500	31.15			BBL-180500X	37.20
.180	.196	.600	.006	.045	.0550	.2500	2.5	BBL-180600	31.15	BBL-180600G	36.10	BBL-180600X	37.20
.180	.196	.750	.006	.045	.0550	.2500	2.5	BBL-180750	31.15	BBL-180750G	36.10		
.180	.196	.900	.006	.045	.0550	.2500	2.5	BBL-180900	31.15			BBL-180900X	37.20
.180	.196	1.000	.006	.045	.0550	.2500	2.5	BBL-1801000	31.15			BBL-1801000X	37.20
.180	.196	1.100	.006	.045	.0550	.2500	2.5	BBL-1801100	31.15				
.180	.196	1.500	.006	.045	.0550	.2500	2.5	BBL-1801500	31.15			BBL-1801500X	37.20
.200	.216	.400	.006	.050	.0750	.2500	2.5	BBL-200400	31.15	BBL-200400G	36.10	BBL-200400X	37.20
.200	.216	.500	.006	.050	.0750	.2500	2.5	BBL-200500	31.15			BBL-200500X	37.20
.200	.216	.600	.006	.050	.0750	.2500	2.5	BBL-200600	31.15	BBL-200600G	36.10		
.200	.216	.700	.006	.050	.0750	.2500	2.5	BBL-200700	31.15			BBL-200700X	37.20
.200	.216	.800	.006	.050	.0750	.2500	2.5	BBL-200800	31.15	BBL-200800G	36.10	BBL-200800X	37.20
.200	.216	1.000	.006	.050	.0750	.2500	2.5	BBL-2001000	31.15			BBL-2001000X	37.20
.200	.216	1.100	.006	.050	.0750	.2500	2.5	BBL-2001100	31.15				
.200	.216	1.200	.006	.050	.0750	.2500	2.5	BBL-2001200	31.15				
.200	.216	1.300	.006	.050	.0750	.2500	2.5	BBL-2001300	31.15				
.230	.250	.600	.006	.057	.0738	.3125	2.5	BBL-230600	41.80	BBL-230600G	48.90	BBL-230600X	49.05
.230	.250	.700	.006	.057	.0738	.3125	2.5	BBL-230700	41.80				
.230	.250	.800	.006	.057	.0738	.3125	2.5	BBL-230800	41.80			BBL-230800X	49.05
.230	.250	.900	.006	.057	.0738	.3125	2.5	BBL-230900	41.80			BBL-230900X	49.05
.230	.250	1.000	.006	.057	.0738	.3125	2.5	BBL-2301000	41.80			BBL-2301000X	49.05
.230	.250	1.200	.006	.057	.0738	.3125	2.5	BBL-2301200	41.80			BBL-2301200X	49.05
.230	.250	1.250	.006	.057	.0738	.3125	2.5	BBL-2301250	41.80				
.230	.250	1.500	.006	.057	.0738	.3125	2.5	BBL-2301500	41.80			BBL-2301500X	49.05
.230	.250	1.600	.006	.057	.0738	.3125	2.5	BBL-2301600	41.80			BBL-2301600X	49.05

*Suggested Minimum Bore Diameter to accommodate chip evacuation and retract clearance in static (not live) applications.

Continued on next page

Standard – Boring Tools



Standard – Boring Tools

BBL

Left Hand (cont.)

Continued from previous page

Head Width	Minimum Bore Dia.*	Maximum Bore Depth	Radius	Projection	Centerline Offset	Shank Dia.	OAL	Uncoated		TiN Coated		AlTiN Coated	
H	L2	$L2 \begin{smallmatrix} +.050'' \\ -.000'' \end{smallmatrix}$	R	P	F	D2 (h6)	L1	Tool #	Price	Tool #	Price	Tool #	Price
.290	.310	.500	.006	.072	.1338	.3125	2.5	BBL-290500	41.80			BBL-290500X	49.05
.290	.310	.600	.006	.072	.1338	.3125	2.5	BBL-290600	41.80			BBL-290600X	49.05
.290	.310	.750	.006	.072	.1338	.3125	2.5	BBL-290750	41.80				
.290	.310	.900	.006	.072	.1338	.3125	2.5	BBL-290900	41.80				
.290	.310	1.000	.006	.072	.1338	.3125	2.5	BBL-2901000	41.80			BBL-2901000X	49.05
.290	.310	1.100	.006	.072	.1338	.3125	2.5	BBL-2901100	41.80				
.290	.310	1.250	.006	.072	.1338	.3125	2.5	BBL-2901250	41.80			BBL-2901250X	49.05
.290	.310	1.350	.006	.072	.1338	.3125	2.5	BBL-2901350	41.80				
.290	.310	1.500	.006	.072	.1338	.3125	2.5	BBL-2901500	41.80			BBL-2901500X	49.05
.320	.340	.600	.006	.080	.1325	.3750	2.5	BBL-320600	57.05	BBL-320600G	64.75		
.320	.340	.750	.006	.080	.1325	.3750	2.5	BBL-320750	57.05			BBL-320750X	65.65
.320	.340	1.000	.006	.080	.1325	.3750	2.5	BBL-3201000	57.05			BBL-3201000X	65.65
.320	.340	1.500	.006	.080	.1325	.3750	2.5	BBL-3201500	57.05			BBL-3201500X	65.65
.320	.340	1.800	.006	.080	.1325	.3750	2.5	BBL-3201800	57.05				
.320	.340	2.000	.006	.080	.1325	.3750	4.0	BBL-3202000	72.95			BBL-3202000X	82.20
.320	.340	2.500	.006	.080	.1325	.3750	4.0	BBL-3202500	72.95				
.320	.340	3.000	.006	.080	.1325	.3750	4.0	BBL-3203000	72.95			BBL-3203000X	82.20
.360	.380	.750	.006	.090	.1725	.3750	2.5	BBL-360750	57.05			BBL-360750X	65.65
.360	.380	.900	.006	.090	.1725	.3750	2.5	BBL-360900	57.05				
.360	.380	1.000	.006	.090	.1725	.3750	2.5	BBL-3601000	57.05				
.360	.380	1.250	.006	.090	.1725	.3750	2.5	BBL-3601250	57.05				
.360	.380	1.500	.006	.090	.1725	.3750	2.5	BBL-3601500	57.05				
.360	.380	1.600	.006	.090	.1725	.3750	2.5	BBL-3601600	57.05				
.360	.380	1.800	.006	.090	.1725	.3750	2.5	BBL-3601800	57.05				
.360	.380	2.500	.006	.090	.1725	.3750	4.0	BBL-3602500	72.95				
.360	.380	3.000	.006	.090	.1725	.3750	4.0	BBL-3603000	72.95			BBL-3603000X	82.20
.490	.510	1.500	.006	.122	.2400	.5000	3.0	BBL-4901500	79.50			BBL-4901500X	91.20
.490	.510	2.600	.006	.122	.2400	.5000	4.0	BBL-4902600	87.15				
.490	.510	3.500	.006	.122	.2400	.5000	6.0	BBL-4903500	109.40				
.490	.510	4.000	.006	.122	.2400	.5000	6.0	BBL-4904000	109.40				
.490	.510	4.500	.006	.122	.2400	.5000	6.0	BBL-4904500	109.40				

*Suggested Minimum Bore Diameter to accommodate chip evacuation and retract clearance in static (not live) applications.

Standard – Boring Tools

HBBC

Standard – Boring Tools

Helical Back Rake – Corner Radius

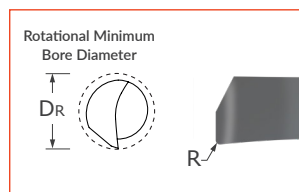
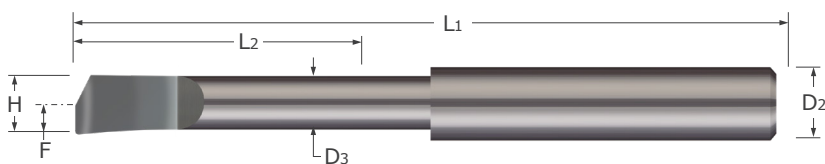

- Designed for boring applications in bores .030" and larger
- Polished face for improved edge retention and chip evacuation while reducing galling
- Helical grind provides ideal top rake for better chip control and freer cutting
- Well suited for machining plastics
- On center neck design allows for static and live/rotating applications
- Lockdown flat automatically locates tool on center
- Corner radius profile
- Solid carbide ■ CNC ground in the USA

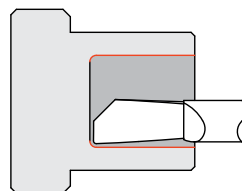

Head Width	Rotational Minimum Bore Diameter	Maximum Bore Depth	Radius	Neck Diameter	Centerline Offset	Shank Diameter	Overall Length	Uncoated	
H	DR	L2 ^{+0.032"} _{-.000"}	R ^{+0.001"} _{-.001"}	D3 ^{+0.000"} _{-.002"}	F	D2 (h6)	L1	Tool #	Price
.0275	.030	.187	.004	.025	.0150	.1250	1.5	HBBC-030187-004	36.15
.0275	.030	.250	.004	.025	.0150	.1250	1.5	HBBC-030250-004	36.15
.0325	.035	.125	.004	.030	.0175	.1250	1.5	HBBC-035125-004	28.25
.0325	.035	.187	.004	.030	.0175	.1250	1.5	HBBC-035187-004	28.25
.0325	.035	.250	.004	.030	.0175	.1250	1.5	HBBC-035250-004	28.25
.0375	.040	.187	.004	.035	.0200	.1250	1.5	HBBC-040187-004	28.25
.0375	.040	.250	.004	.035	.0200	.1250	1.5	HBBC-040250-004	28.25
.0375	.040	.312	.004	.035	.0200	.1250	1.5	HBBC-040312-004	28.25
.0450	.050	.187	.004	.040	.0250	.1250	1.5	HBBC-050187-004	28.25
.0450	.050	.312	.004	.040	.0250	.1250	1.5	HBBC-050312-004	28.25
.0450	.050	.375	.004	.040	.0250	.1250	1.5	HBBC-050375-004	28.25
.0550	.060	.250	.004	.050	.0300	.1250	1.5	HBBC-060250-004	28.25
.0550	.060	.375	.004	.050	.0300	.1250	1.5	HBBC-060375-004	28.25
.0550	.060	.500	.004	.050	.0300	.1250	1.5	HBBC-060500-004	28.25
.0650	.070	.312	.004	.060	.0350	.1250	1.5	HBBC-070312-004	28.25
.0650	.070	.437	.004	.060	.0350	.1250	1.5	HBBC-070437-004	28.25
.0650	.070	.562	.004	.060	.0350	.1250	1.5	HBBC-070562-004	28.25
.0750	.080	.375	.004	.070	.0400	.1250	1.5	HBBC-080375-004	28.25
.0750	.080	.500	.004	.070	.0400	.1250	1.5	HBBC-080500-004	28.25
.0750	.080	.625	.004	.070	.0400	.1250	1.5	HBBC-080625-004	28.25
.0850	.090	.375	.004	.080	.0450	.1250	1.5	HBBC-090375-004	28.25
.0850	.090	.500	.004	.080	.0450	.1250	1.5	HBBC-090500-004	28.25
.0850	.090	.687	.004	.080	.0450	.1250	1.5	HBBC-090687-004	28.25
.0950	.100	.437	.004	.090	.0500	.1250	1.5	HBBC-100437-004	28.25
.0950	.100	.562	.004	.090	.0500	.1250	1.5	HBBC-100562-004	28.25
.0950	.100	.750	.004	.090	.0500	.1250	1.5	HBBC-100750-004	28.25

Continued on next page

Standard – Boring Tools

Helical Back Rake – Corner Radius (cont.)

Continued from previous page

Head Width	Rotational Minimum Bore Diameter	Maximum Bore Depth	Radius	Neck Diameter	Centerline Offset	Shank Diameter	Overall Length	Uncoated	
H	DR	L ₂ ^{+0.032"} _{-.000"}	R ^{+0.001"} _{-.001"}	D ₃ ^{+0.000"} _{-.002"}	F	D ₂ (h6)	L ₁	Tool #	Price
.1100	.120	.500	.004	.100	.0600	.1250	1.5	HBBC-120500-004	28.25
.1100	.120	.625	.004	.100	.0600	.1250	1.5	HBBC-120625-004	28.25
.1100	.120	1.000	.004	.100	.0600	.1250	1.5	HBBC-1201000-004	28.25
.1225	.135	.562	.004	.110	.0675	.1875	2.0	HBBC-135562-004	30.35
.1225	.135	.750	.004	.110	.0675	.1875	2.0	HBBC-135750-004	30.35
.1225	.135	1.000	.004	.110	.0675	.1875	2.0	HBBC-1351000-004	30.35
.1400	.150	.625	.004	.130	.0750	.1875	2.0	HBBC-150625-004	30.35
.1400	.150	1.000	.004	.130	.0750	.1875	2.0	HBBC-1501000-004	30.35
.1400	.150	1.250	.004	.130	.0750	.1875	2.0	HBBC-1501250-004	30.35
.1700	.180	1.000	.004	.160	.0900	.1875	2.0	HBBC-1801000-004	30.35
.1700	.180	1.250	.004	.160	.0900	.1875	2.0	HBBC-1801250-004	30.35
.1700	.180	1.500	.004	.160	.0900	.1875	2.0	HBBC-1801500-004	30.35
.1975	.210	1.000	.004	.185	.1050	.2500	2.5	HBBC-2101000-004	32.75
.1975	.210	1.250	.004	.185	.1050	.2500	2.5	HBBC-2101250-004	32.75
.1975	.210	1.500	.004	.185	.1050	.2500	2.5	HBBC-2101500-004	32.75
.2275	.240	1.000	.004	.215	.1200	.2500	2.5	HBBC-2401000-004	32.75
.2275	.240	1.500	.004	.215	.1200	.2500	2.5	HBBC-2401500-004	32.75
.2275	.240	1.750	.004	.215	.1200	.2500	2.5	HBBC-2401750-004	32.75
.2750	.300	1.000	.004	.250	.1500	.3125	2.5	HBBC-3001000-004	44.15
.2750	.300	1.500	.004	.250	.1500	.3125	2.5	HBBC-3001500-004	44.15
.2750	.300	1.750	.004	.250	.1500	.3125	2.5	HBBC-3001750-004	44.15
.3400	.360	1.000	.004	.320	.1800	.3750	2.5	HBBC-3601000-004	60.70
.3400	.360	1.500	.004	.320	.1800	.3750	2.5	HBBC-3601500-004	60.70
.3400	.360	2.000	.004	.320	.1800	.3750	4.0	HBBC-3602000-004	77.55
.3400	.360	2.500	.004	.320	.1800	.3750	4.0	HBBC-3602500-004	77.55

Standard – Boring Tools

Technical Resources on Micro100.com

Find Simulation Files, Speeds & Feeds, Torque Recommendations, Programs, Blogs, and more at micro100.com/resources

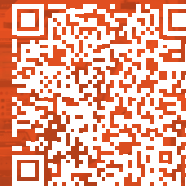

See pgs 33-37 for standard tool holders

HBB / HBM

Standard – Boring Tools

Helical Back Rake

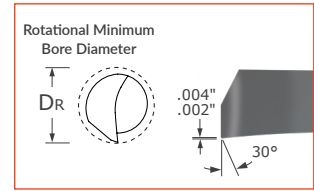
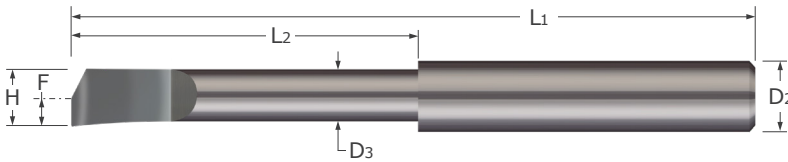

- Designed for boring applications in bores .020" and larger
- Polished face for improved edge retention and chip evacuation while reducing galling
- Helical grind provides ideal top rake for better chip control and freer cutting
- Uncoated variant ideal for plastics
- On center neck design allows for static and live/rotating applications
- Cylindrical shank (no set screw flat)
- AlTiN coated option provides added lubricity and increased wear resistance in difficult to machine materials
- Solid carbide ■ CNC ground in the USA

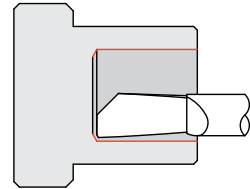

Head Width		Rotational Min. Bore Diameter	Max. Bore Depth	Neck Diameter	Centerline Offset	Shank Dia.	Overall Length	Uncoated		AlTiN Coated	
H	decimal equiv.	DR	L2 +.032" -.000" +.81 mm -.00 mm	D3 +.000" -.002" +.00 mm -.05 mm	F	D2 (h6)	L1	Tool #	Price	Tool #	Price
.0175	.0175	.020	.063	.015	.0100	.1250	1.5	HBB-020062	34.55	HBB-020062X	38.65
0.45 mm	.0177	0.5 mm	2 mm	0.4 mm	0.25 mm	3 mm	38 mm	HBM-005002	31.35		
.0225	.0225	.025	.125	.020	.0125	.1250	1.5	HBB-025125	34.55	HBB-025125X	38.65
0.65 mm	.0256	0.7 mm	3 mm	0.6 mm	0.35 mm	3 mm	38 mm	HBM-007003	31.35		
.0275	.0275	.030	.188	.025	.0150	.1250	1.5	HBB-030187	34.55	HBB-030187X	38.65
0.75 mm	.0295	0.8 mm	4 mm	0.7 mm	0.40 mm	3 mm	38 mm	HBM-008004	31.35		
.0325	.0325	.035	.125	.030	.0175	.1250	1.5	HBB-035125	26.60		
.0325	.0325	.035	.188	.030	.0175	.1250	1.5	HBB-035187	26.60	HBB-035187X	30.50
0.90 mm	.0354	1.0 mm	6 mm	0.8 mm	0.50 mm	3 mm	38 mm	HBM-010006	24.25		
.0375	.0375	.040	.188	.035	.0200	.1250	1.5	HBB-040187	26.60	HBB-040187X	30.50
.0375	.0375	.040	.250	.035	.0200	.1250	1.5	HBB-040250	26.60	HBB-040250X	30.50
.0450	.0450	.050	.313	.040	.0250	.1250	1.5	HBB-050312	26.60	HBB-050312X	30.50
1.35 mm	.0531	1.5 mm	9 mm	1.2 mm	0.75 mm	3 mm	38 mm	HBM-015009	24.25		
.0550	.0550	.060	.375	.050	.0300	.1250	1.5	HBB-060375	26.60	HBB-060375X	30.50
1.63 mm	.0642	1.75 mm	10 mm	1.5 mm	0.875 mm	3 mm	38 mm	HBM-017510	24.25		
.0650	.0650	.070	.438	.060	.0350	.1250	1.5	HBB-070437	26.60	HBB-070437X	30.50
.0750	.0750	.080	.500	.070	.0400	.1250	1.5	HBB-080500	26.60	HBB-080500X	30.50
2.05 mm	.0807	2.26 mm	12 mm	1.9 mm	1.13 mm	3 mm	38 mm	HBM-022512	24.25		
.0850	.0850	.090	.500	.080	.0450	.1250	1.5	HBB-090500	26.60	HBB-090500X	30.50
.0950	.0950	.100	.563	.090	.0500	.1250	1.5	HBB-100562	26.60	HBB-100562X	30.50
2.58 mm	.1016	2.75 mm	14 mm	2.4 mm	1.375 mm	3 mm	38 mm	HBM-027514	24.25		
2.75 mm	.1083	3.0 mm	16 mm	2.5 mm	1.50 mm	4 mm	50 mm	HBM-030016	25.05		

Continued on next page

Standard – Boring Tools

HBB / HBM

Helical Back Rake (cont.)

Continued from previous page

Head Width		Rotational Min. Bore Diameter	Max. Bore Depth	Neck Diameter	Centerline Offset	Shank Dia.	Overall Length	Uncoated		AlTiN Coated	
H	decimal equiv.	DR	L ₂ +.032" -.000" +.81 mm -.00 mm	D ₃ +.000" -.002" +.00 mm -.05 mm	F	D ₂ (h6)	L ₁	Tool #	Price	Tool #	Price
.1100	.1100	.120	.625	.100	.0600	.1250	1.5	HBB-120625	26.60	HBB-120625X	30.50
.1100	.1100	.120	1.000	.100	.0600	.1250	1.5	HBB-1201000	26.60	HBB-1201000X	30.50
.1225	.1225	.135	.750	.110	.0675	.1875	2.0	HBB-135750	28.50	HBB-135750X	32.85
.1225	.1225	.135	1.000	.110	.0675	.1875	2.0	HBB-1351000	28.50	HBB-1351000X	32.85
.1400	.1400	.150	1.000	.130	.0750	.1875	2.0	HBB-1501000	28.50	HBB-1501000X	32.85
.1400	.1400	.150	1.250	.130	.0750	.1875	2.0	HBB-1501250	28.50	HBB-1501250X	32.85
3.65 mm	.1437	4.0 mm	25 mm	3.3 mm	2.00 mm	6 mm	57 mm			HBM-040025X	38.60
4.15 mm	.1634	4.5 mm	30 mm	3.8 mm	2.25 mm	6 mm	57 mm	HBM-045030	28.05		
.1700	.1700	.180	1.000	.160	.0900	.1875	2.0	HBB-1801000	28.50	HBB-1801000X	32.85
.1700	.1700	.180	1.250	.160	.0900	.1875	2.0	HBB-1801250	28.50	HBB-1801250X	32.85
.1700	.1700	.180	1.500	.160	.0900	.1875	2.0	HBB-1801500	28.50	HBB-1801500X	32.85
.1975	.1975	.210	1.000	.185	.1050	.2500	2.5	HBB-2101000	30.90	HBB-2101000X	36.95
.1975	.1975	.210	1.250	.185	.1050	.2500	2.5	HBB-2101250	30.90	HBB-2101250X	36.95
.1975	.1975	.210	1.500	.185	.1050	.2500	2.5	HBB-2101500	30.90	HBB-2101500X	36.95
5.15 mm	.2028	5.5 mm	35 mm	4.7 mm	2.75 mm	6 mm	57 mm	HBM-055035	28.05		
.2275	.2275	.240	1.000	.215	.1200	.2500	2.5	HBB-2401000	30.90	HBB-2401000X	36.95
.2275	.2275	.240	1.500	.215	.1200	.2500	2.5	HBB-2401500	30.90	HBB-2401500X	36.95
.2275	.2275	.240	1.750	.215	.1200	.2500	2.5	HBB-2401750	30.90	HBB-2401750X	36.95
.2750	.2750	.300	1.000	.250	.1500	.3125	2.5	HBB-3001000	42.20	HBB-3001000X	49.45
.2750	.2750	.300	1.500	.250	.1500	.3125	2.5	HBB-3001500	42.20	HBB-3001500X	49.45
.2750	.2750	.300	1.750	.250	.1500	.3125	2.5	HBB-3001750	42.20	HBB-3001750X	49.45
.3400	.3400	.360	1.000	.320	.1800	.3750	2.5	HBB-3601000	58.60		
.3400	.3400	.360	1.500	.320	.1800	.3750	2.5	HBB-3601500	58.60	HBB-3601500X	67.20
.3400	.3400	.360	2.000	.320	.1800	.3750	4.0	HBB-3602000	75.50	HBB-3602000X	84.75
.3400	.3400	.360	2.250	.320	.1800	.3750	4.0	HBB-3602250	75.50		
.3400	.3400	.360	2.500	.320	.1800	.3750	4.0	HBB-3602500	75.50	HBB-3602500X	84.75
.4600	.4600	.480	2.500	.440	.2400	.5000	4.0	HBB-4802500	90.55		
.4600	.4600	.480	3.000	.440	.2400	.5000	4.0	HBB-4803000	90.55		

Standard – Boring Tools

See pgs 33-37 for standard tool holders

PBT

Standard – Boring Tools

Top Rake Chipbreaker

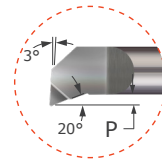
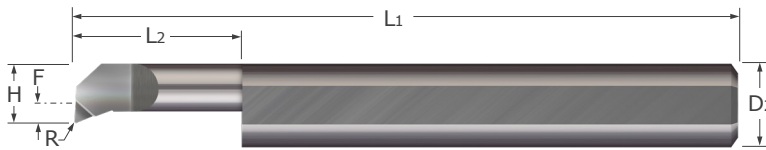

- Optimized for finishing operations
- Top rake geometry provides freer cutting
- Polished face for reducing galling
- Corner radius profile
- Lockdown flat automatically locates tool on center
- AlTiN coated option provides added lubricity and increased wear resistance in difficult to machine materials
- Solid carbide ■ CNC ground in the USA

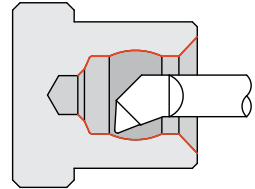

Head Width	Minimum Bore Dia.*	Maximum Bore Depth	Radius	Projection	Centerline Offset	Shank Diameter	Overall Length	Uncoated		AlTiN Coated	
								Tool #	Price	Tool #	Price
H	L ₂	$L_2 \begin{smallmatrix} +.030'' \\ -.000'' \end{smallmatrix}$	$R \begin{smallmatrix} +.003'' \\ -.000'' \end{smallmatrix}$	P	F	D ₂ (h6)	L ₁				
.0500	.0550	.150	.002	.005	-.0125	.1250	1.5	PBT2-050150	28.45	PBT2-050150X	32.40
.0500	.0550	.200	.002	.005	-.0125	.1250	1.5	PBT2-050200	28.45	PBT2-050200X	32.40
.0500	.0550	.400	.002	.005	-.0125	.1250	1.5	PBT2-050400	28.45	PBT2-050400X	32.40
.0500	.0550	.500	.002	.005	-.0125	.1250	1.5	PBT2-050500	28.45	PBT2-050500X	32.40
.0600	.0700	.150	.002	.010	-.0025	.1250	1.5	PBT2-060150	28.45	PBT2-060150X	32.40
.0600	.0700	.200	.002	.010	-.0025	.1250	1.5	PBT2-060200	28.45	PBT2-060200X	32.40
.0600	.0700	.400	.002	.010	-.0025	.1250	1.5	PBT2-060400	28.45	PBT2-060400X	32.40
.0600	.0700	.500	.002	.010	-.0025	.1250	1.5	PBT2-060500	28.45	PBT2-060500X	32.40
.0700	.0800	.150	.002	.015	.0075	.1250	1.5	PBT2-070150	27.80	PBT2-070150X	31.70
.0700	.0800	.200	.002	.015	.0075	.1250	1.5	PBT2-070200	27.80	PBT2-070200X	31.70
.0700	.0800	.400	.002	.015	.0075	.1250	1.5	PBT2-070400	27.80	PBT2-070400X	31.70
.0700	.0800	.600	.002	.015	.0075	.1250	1.5	PBT2-070600	27.80	PBT2-070600X	31.70
.0800	.0900	.200	.002	.015	.0175	.1250	1.5	PBT2-080200	27.80	PBT2-080200X	31.70
.0800	.0900	.400	.002	.015	.0175	.1250	1.5	PBT2-080400	27.80	PBT2-080400X	31.70
.0900	.1000	.200	.002	.015	.0275	.1250	1.5	PBT2-090200	27.80	PBT2-090200X	31.70
.0900	.1000	.400	.002	.015	.0275	.1250	1.5	PBT2-090400	27.80	PBT2-090400X	31.70
.1000	.1100	.200	.002	.015	.0375	.1250	1.5	PBT2-100200	27.80	PBT2-100200X	31.70
.1000	.1100	.400	.002	.015	.0375	.1250	1.5	PBT2-100400	27.80	PBT2-100400X	31.70
.1100	.1220	.250	.004	.020	.0475	.1250	1.5	PBT4-110250	27.80	PBT4-110250X	31.70
.1100	.1220	.500	.004	.020	.0475	.1250	1.5	PBT4-110500	27.80	PBT4-110500X	31.70
.1100	.1220	.750	.004	.020	.0475	.1250	1.5	PBT4-110750	27.80	PBT4-110750X	31.70
.1200	.1320	.250	.004	.020	.0263	.1875	2.0	PBT-120250	28.95	PBT-120250X	33.40
.1200	.1320	.375	.004	.020	.0263	.1875	2.0	PBT4-120375	28.95	PBT4-120375X	33.40
.1200	.1320	.500	.004	.020	.0263	.1875	2.0	PBT-120500	28.95	PBT-120500X	33.40
.1200	.1320	.750	.004	.020	.0263	.1875	2.0	PBT-120750	28.95	PBT-120750X	33.40
.1200	.1320	1.000	.004	.020	.0263	.1875	2.0	PBT-1201000	28.95	PBT-1201000X	33.40
.1400	.1520	.250	.002	.025	.0463	.1875	2.0	PBT2-140250	28.95	PBT2-140250X	33.40
.1400	.1520	.250	.004	.025	.0463	.1875	2.0	PBT4-140250	28.95	PBT4-140250X	33.40
.1400	.1520	.375	.002	.025	.0463	.1875	2.0	PBT2-140375	28.95	PBT2-140375X	33.40
.1400	.1520	.375	.004	.025	.0463	.1875	2.0	PBT4-140375	28.95	PBT4-140375X	33.40
.1400	.1520	.500	.002	.025	.0463	.1875	2.0	PBT2-140500	28.95	PBT2-140500X	33.40
.1400	.1520	.500	.004	.025	.0463	.1875	2.0	PBT4-140500	28.95	PBT4-140500X	33.40

*Suggested Minimum Bore Diameter to accommodate chip evacuation and retract clearance in static (not live) applications.

Continued on next page

See pgs 33-37 for standard tool holders

Standard – Boring Tools

PBT

Top Rake Chipbreaker (cont.)

Continued from previous page

Head Width	Minimum Bore Dia.*	Maximum Bore Depth	Radius	Projection	Centerline Offset	Shank Diameter	Overall Length	Uncoated		AITIN Coated	
								Tool #	Price	Tool #	Price
H		L ₂ ^{+ .030"} / _{-.000"}	R ^{+ .003"} / _{-.000"}	P	F	D ₂ (h6)	L ₁				
.1600	.1760	.375	.006	.025	.0663	.1875	2.0	PBT6-160375	28.95	PBT6-160375X	33.40
.1600	.1760	.500	.006	.025	.0663	.1875	2.0	PBT-160500	28.95	PBT-160500X	33.40
.1600	.1760	.750	.006	.025	.0663	.1875	2.0	PBT-160750	28.95	PBT-160750X	33.40
.1600	.1760	1.000	.006	.025	.0663	.1875	2.0	PBT6-1601000	28.95	PBT6-1601000X	33.40
.1600	.1760	1.250	.006	.025	.0663	.1875	2.0	PBT6-1601250	28.95	PBT6-1601250X	33.40
.1800	.1960	.375	.006	.030	.0550	.2500	2.5	PBT6-180375	37.10	PBT6-180375X	43.15
.1800	.1960	.500	.006	.030	.0550	.2500	2.5	PBT-180500	37.10	PBT-180500X	43.15
.1800	.1960	.750	.006	.030	.0550	.2500	2.5	PBT6-180750	37.10	PBT6-180750X	43.15
.1800	.1960	1.000	.006	.030	.0550	.2500	2.5	PBT-1801000	37.10	PBT-1801000X	43.15
.1800	.1960	1.250	.006	.030	.0550	.2500	2.5	PBT6-1801250	37.10	PBT6-1801250X	43.15
.1800	.1960	1.500	.006	.030	.0550	.2500	2.5	PBT6-1801500	37.10	PBT6-1801500X	43.15
.2000	.2160	.375	.006	.030	.0750	.2500	2.5	PBT6-200375	37.10	PBT6-200375X	43.15
.2000	.2160	.600	.006	.030	.0750	.2500	2.5	PBT-200600	37.10	PBT-200600X	43.15
.2000	.2160	.750	.006	.030	.0750	.2500	2.5	PBT6-200750	37.10	PBT6-200750X	43.15
.2000	.2160	1.000	.006	.030	.0750	.2500	2.5	PBT-2001000	37.10	PBT-2001000X	43.15
.2000	.2160	1.250	.006	.030	.0750	.2500	2.5	PBT6-2001250	37.10	PBT6-2001250X	43.15
.2000	.2160	1.500	.006	.030	.0750	.2500	2.5	PBT6-2001500	37.10	PBT6-2001500X	43.15
.2300	.2500	.500	.004	.040	.0738	.3125	2.5	PBT4-230500	45.85	PBT4-230500X	53.10
.2300	.2500	.500	.006	.040	.0738	.3125	2.5	PBT6-230500	45.85	PBT6-230500X	53.10
.2300	.2500	.750	.004	.040	.0738	.3125	2.5	PBT4-230750	45.85	PBT4-230750X	53.10
.2300	.2500	.750	.006	.040	.0738	.3125	2.5	PBT-230750	45.85	PBT-230750X	53.10
.2300	.2500	1.100	.006	.040	.0738	.3125	2.5	PBT6-2301100	45.85	PBT6-2301100X	53.10
.2300	.2500	1.300	.006	.040	.0738	.3125	2.5	PBT6-2301300	45.85	PBT6-2301300X	53.10
.2300	.2500	1.600	.006	.040	.0738	.3125	3.0	PBT-2301600	54.50	PBT-2301600X	61.75
.2600	.2800	.500	.004	.045	.1038	.3125	2.5	PBT4-260500	45.85	PBT4-260500X	53.10
.2600	.2800	.500	.006	.045	.1038	.3125	2.5	PBT6-260500	45.85	PBT6-260500X	53.10
.2600	.2800	.750	.004	.045	.1038	.3125	2.5	PBT4-260750	45.85	PBT4-260750X	53.10
.2600	.2800	.750	.006	.045	.1038	.3125	2.5	PBT6-260750	45.85	PBT6-260750X	53.10
.3000	.3200	.750	.006	.050	.1125	.3750	2.5	PBT6-300750	55.40	PBT6-300750X	64.00
.3000	.3200	1.000	.006	.050	.1125	.3750	2.5	PBT-3001000	55.40	PBT-3001000X	64.00
.3000	.3200	1.250	.006	.050	.1125	.3750	2.5	PBT6-3001250	55.40	PBT6-3001250X	64.00
.3000	.3200	1.600	.006	.050	.1125	.3750	3.0	PBT6-3001600	55.40	PBT6-3001600X	64.00
.3000	.3200	2.100	.006	.050	.1125	.3750	3.5	PBT6-3002100	55.40	PBT6-3002100X	64.65

*Suggested Minimum Bore Diameter to accommodate chip evacuation and retract clearance in static (not live) applications.

Standard – Boring Tools

TBB

Standard – Boring Tools

Right Hand – Brazed – Sharp

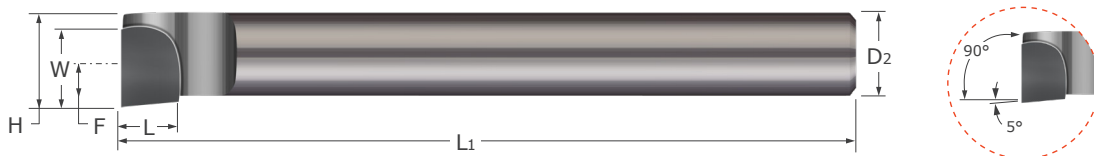

- Designed for right hand facing and boring applications in bores .320" and larger
- Long shank enables flexible reach options (preset at any length)
- Sharp corner profile
- Solid carbide tipped with zinc coated steel shank for durability and corrosion resistance
- CNC ground in the USA

Head Width	Width	Length	Centerline Offset	Shank Diameter	Overall Length	Brazed Style	
H	W	L	F	D2 ^{+0.000"} _{-.003"}	L1	Tool #	Price
.320	.250	.188	.195	.2500	4.0	TBB-250	24.45
.413	.313	.250	.257	.3125	5.0	TBB-312	25.55
.463	.313	.250	.276	.3750	6.0	TBB-375	27.40
.625	.500	.250	.375	.5000	7.0	TBB-500	34.05
.795	.500	.250	.483	.6250	8.0	TBB-625	36.90
.935	.625	.250	.560	.7500	9.0	TBB-750	38.10
1.233	.750	.375	.733	1.0000	10.0	TBB-001	46.40

See pgs 33-37 for standard tool holders

See pg 310 for tool set options

TBBL

Standard – Boring Tools

Left Hand – Brazed – Sharp

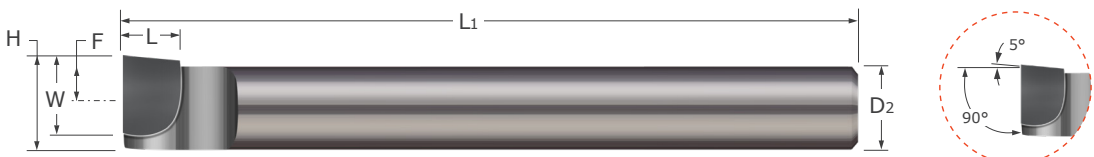

- Designed for left hand facing and boring applications in bores .320" and larger
- Long shank enables flexible reach options (preset at any length)
- Sharp corner profile
- Solid carbide tipped with zinc coated steel shank for durability and corrosion resistance
- CNC ground in the USA

Head Width	Width	Length	Centerline Offset	Shank Diameter	Overall Length	Brazed Style	
H	W	L	F	D2 ^{+0.000"} _{-.003"}	L1	Tool #	Price
.320	.250	.188	.195	.2500	4.0	TBBL-250	23.80
.413	.313	.250	.257	.3125	5.0	TBBL-312	24.45
.463	.313	.250	.276	.3750	6.0	TBBL-375	26.20
.625	.500	.250	.375	.5000	7.0	TBBL-500	33.95
.795	.500	.250	.483	.6250	8.0	TBBL-625	36.30
.935	.625	.250	.560	.7500	9.0	TBBL-750	37.20
1.233	.750	.375	.733	1.0000	10.0	TBBL-001	46.40

See pgs 33-37 for standard tool holders

See pg 310 for tool set options

Standard – Boring Tools

Right Hand – Brazed – Corner Radius

TBBC

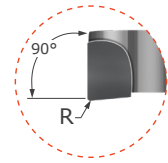
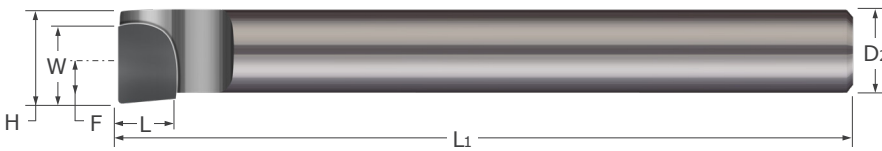

- Designed for right hand facing and boring applications in bores .320" and larger
- Long shank enables flexible reach options (preset at any length)
- Corner radius profile
- Solid carbide tipped with zinc coated steel shank for durability and corrosion resistance
- CNC ground in the USA

Head Width	Radius	Width	Length	Centerline Offset	Shank Diameter	Overall Length	Brazed Style	
H	R $\begin{smallmatrix} +.001" \\ -.001" \end{smallmatrix}$	W	L	F	D2 $\begin{smallmatrix} +.0000" \\ -.0030" \end{smallmatrix}$	L1	Tool #	Price
.320	.008	.250	.188	.195	.2500	4.0	TBBC-250-008	26.30
.413	.008	.313	.250	.257	.3125	5.0	TBBC-312-008	27.40
.463	.008	.313	.250	.276	.3750	6.0	TBBC-375-008	29.25
.625	.008	.500	.250	.375	.5000	7.0	TBBC-500-008	35.90
.795	.008	.500	.250	.483	.6250	8.0	TBBC-625-008	38.75
.935	.008	.625	.250	.560	.7500	9.0	TBBC-750-008	39.95
1.233	.008	.750	.375	.733	1.0000	10.0	TBBC-001-008	46.40

See pgs 33-37 for standard tool holders

Standard – Boring Tools

Standard – Boring Tools

Left Hand – Brazed – Corner Radius

TBBCL

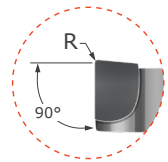
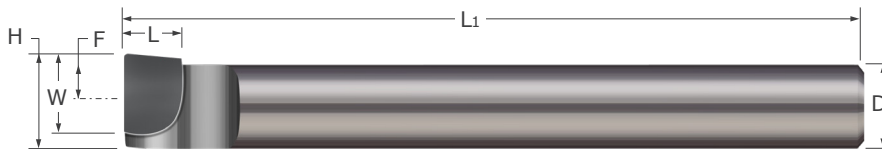

- Designed for left hand facing and boring applications in bores .320" and larger
- Long shank enables flexible reach options (preset at any length)
- Corner radius profile
- Solid carbide tipped with zinc coated steel shank for durability and corrosion resistance
- CNC ground in the USA

Head Width	Radius	Width	Length	Centerline Offset	Shank Diameter	Overall Length	Brazed Style	
H	R $\begin{smallmatrix} +.001" \\ -.001" \end{smallmatrix}$	W	L	F	D2 $\begin{smallmatrix} +.0000" \\ -.0030" \end{smallmatrix}$	L1	Tool #	Price
.320	.008	.250	.188	.195	.2500	4.0	TBBCL-250-008	26.30
.413	.008	.313	.250	.257	.3125	5.0	TBBCL-312-008	27.40
.463	.008	.313	.250	.276	.3750	6.0	TBBCL-375-008	29.25
.625	.008	.500	.250	.375	.5000	7.0	TBBCL-500-008	35.90
.795	.008	.500	.250	.483	.6250	8.0	TBBCL-625-008	38.75
.935	.008	.625	.250	.560	.7500	9.0	TBBCL-750-008	39.95
1.233	.008	.750	.375	.733	1.0000	10.0	TBBCL-001-008	46.40

See pgs 33-37 for standard tool holders

PR

Standard - Profiling Tools

Radial Profiling

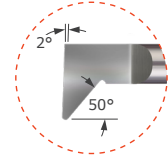
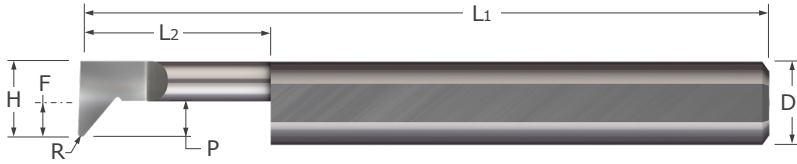

- Designed for radial profiling
- Excellent choice for fine finishing
- Can be used in thread relief applications
- Split face geometry provides optimal edge strength
- Corner radius profile
- Lockdown flat automatically locates tool on center
- AlTiN coated option provides added lubricity and increased wear resistance in difficult to machine materials
- Solid carbide ■ CNC ground in the USA

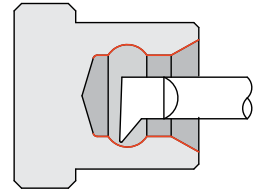

Head Width	Minimum Bore Dia.*	Maximum Bore Depth	Radius	Projection	Centerline Offset	Shank Diameter	Overall Length	Uncoated		AlTiN Coated	
								Tool #	Price	Tool #	Price
H		L2 ^{+0.050"} / _{-.000"}	R ^{+0.002"} / _{-.000"}	P	F	D2 (h6)	L1				
.0500	.0550	.150	.002	.015	-.0125	.1250	1.5	PR2-050150	28.55	PR2-050150X	32.50
.0500	.0550	.200	.002	.015	-.0125	.1250	1.5	PR2-050200	28.55	PR2-050200X	32.50
.0600	.0700	.150	.002	.020	-.0025	.1250	1.5	PR2-060150	28.55	PR2-060150X	32.50
.0600	.0700	.200	.002	.020	-.0025	.1250	1.5	PR2-060200	28.55	PR2-060200X	32.50
.0700	.0800	.150	.002	.025	.0075	.1250	1.5	PR2-070150	27.90	PR2-070150X	31.80
.0700	.0800	.200	.002	.025	.0075	.1250	1.5	PR2-070200	27.90	PR2-070200X	31.80
.0700	.0800	.200	.005	.025	.0075	.1250	1.5	PR-070200	27.90	PR-070200X	31.80
.0700	.0800	.300	.002	.025	.0075	.1250	1.5	PR2-070300	27.90	PR2-070300X	31.80
.0700	.0800	.500	.002	.025	.0075	.1250	1.5	PR2-070500	27.90	PR2-070500X	31.80
.0700	.0800	.500	.005	.025	.0075	.1250	1.5	PR-070500	27.90	PR-070500X	31.80
.0800	.0900	.200	.002	.030	.0175	.1250	1.5	PR2-080200	27.90	PR2-080200X	31.80
.0800	.0900	.300	.002	.030	.0175	.1250	1.5	PR2-080300	27.90	PR2-080300X	31.80
.0900	.1000	.200	.002	.030	.0275	.1250	1.5	PR2-090200	27.90	PR2-090200X	31.80
.0900	.1000	.300	.002	.030	.0275	.1250	1.5	PR2-090300	27.90	PR2-090300X	31.80
.1000	.1100	.200	.002	.035	.0375	.1250	1.5	PR2-100200	27.90	PR2-100200X	31.80
.1000	.1100	.200	.005	.035	.0375	.1250	1.5	PR5-100200	27.90	PR5-100200X	31.80
.1000	.1100	.300	.002	.035	.0375	.1250	1.5	PR2-100300	27.90	PR2-100300X	31.80
.1000	.1100	.300	.005	.035	.0375	.1250	1.5	PR5-100300	27.90	PR5-100300X	31.80
.1100	.1240	.250	.005	.040	.0475	.1250	1.5	PR-110250	27.90	PR-110250X	31.80
.1100	.1240	.375	.005	.040	.0475	.1250	1.5	PR5-110375	27.90	PR5-110375X	31.80
.1100	.1240	.500	.005	.040	.0475	.1250	1.5	PR5-110500	27.90	PR5-110500X	31.80
.1200	.1340	.250	.008	.050	.0263	.1875	2.0	PR-120250	29.00	PR-120250X	33.45
.1200	.1340	.375	.005	.050	.0263	.1875	2.0	PR5-120375	29.00	PR5-120375X	33.45
.1200	.1340	.375	.008	.050	.0263	.1875	2.0	PR8-120375	29.00	PR8-120375X	33.45
.1200	.1340	.500	.008	.050	.0263	.1875	2.0	PR-120500	29.00	PR-120500X	33.45
.1200	.1340	.750	.005	.050	.0263	.1875	2.0	PR5-120750	29.00	PR5-120750X	33.45
.1200	.1340	.750	.008	.050	.0263	.1875	2.0	PR8-120750	29.00	PR8-120750X	33.45

*Suggested Minimum Bore Diameter to accommodate chip evacuation and retract clearance in static (not live) applications.

Continued on next page

See pgs 33-37 for standard tool holders



Standard – Profiling Tools

PR

Radial Profiling (cont.)

Continued from previous page

Head Width	Minimum Bore Dia.*	Maximum Bore Depth	Radius	Projection	Centerline Offset	Shank Diameter	Overall Length	Uncoated		A1TiN Coated	
								H	L2	R	P
.1400	.1540	.375	.005	.050	.0463	.1875	2.0	PR5-140375	29.00	PR5-140375X	33.45
.1400	.1540	.375	.008	.050	.0463	.1875	2.0	PR8-140375	29.00	PR8-140375X	33.45
.1400	.1540	.500	.005	.050	.0463	.1875	2.0	PR5-140500	29.00	PR5-140500X	33.45
.1400	.1540	.500	.008	.050	.0463	.1875	2.0	PR8-140500	29.00	PR8-140500X	33.45
.1600	.1780	.375	.008	.050	.0663	.1875	2.0	PR8-160375	29.00	PR8-160375X	33.45
.1600	.1780	.500	.008	.050	.0663	.1875	2.0	PR-160500	29.00	PR-160500X	33.45
.1600	.1780	.750	.008	.050	.0663	.1875	2.0	PR8-160750	29.00	PR8-160750X	33.45
.1600	.1780	1.000	.008	.050	.0663	.1875	2.0	PR8-1601000	29.00	PR8-1601000X	33.45
.1800	.1980	.375	.008	.080	.0550	.2500	2.5	PR8-180375	37.15	PR8-180375X	43.20
.1800	.1980	.500	.008	.080	.0550	.2500	2.5	PR-180500	37.15	PR-180500X	43.20
.1800	.1980	.750	.008	.080	.0550	.2500	2.5	PR-180750	37.15	PR-180750X	43.20
.1800	.1980	1.000	.008	.080	.0550	.2500	2.5	PR8-1801000	37.15	PR8-1801000X	43.20
.2000	.2180	.500	.005	.080	.0750	.2500	2.5	PR5-200500	37.15	PR5-200500X	43.20
.2000	.2180	.500	.008	.080	.0750	.2500	2.5	PR8-200500	37.15	PR8-200500X	43.20
.2000	.2180	.750	.005	.080	.0750	.2500	2.5	PR5-200750	37.15	PR5-200750X	43.20
.2000	.2180	.750	.008	.080	.0750	.2500	2.5	PR8-200750	37.15	PR8-200750X	43.20
.2300	.2520	.500	.008	.080	.0738	.3125	2.5	PR8-230500	45.85	PR8-230500X	53.10
.2300	.2520	.750	.008	.080	.0738	.3125	2.5	PR-230750	45.85	PR-230750X	53.10
.2300	.2520	1.000	.008	.080	.0738	.3125	2.5	PR-2301000	45.85	PR-2301000X	53.10
.2300	.2520	1.250	.008	.080	.0738	.3125	2.5	PR8-2301250	45.85	PR8-2301250X	53.10
.2600	.2820	.750	.008	.090	.1038	.3125	2.5	PR8-260750	45.85	PR8-260750X	53.10
.2600	.2820	1.000	.008	.090	.1038	.3125	2.5	PR8-2601000	45.85	PR8-2601000X	53.10
.3000	.3220	.750	.008	.110	.1438	.3125	2.5	PR8-300750	45.85	PR8-300750X	53.10
.3000	.3220	1.000	.008	.110	.1438	.3125	2.5	PR-3001000	45.85	PR-3001000X	53.10
.3000	.3220	1.250	.008	.110	.1438	.3125	2.5	PR-3001250	45.85	PR-3001250X	53.10
.3600	.3820	.750	.008	.130	.1725	.3750	2.5	PR8-360750	59.45	PR8-360750X	68.05
.3600	.3820	1.000	.008	.130	.1725	.3750	2.5	PR-3601000	59.45	PR-3601000X	68.05
.3600	.3820	1.250	.008	.130	.1725	.3750	2.5	PR-3601250	59.45	PR-3601250X	68.05
.4600	.4820	.750	.008	.150	.2100	.5000	3.0	PR8-460750	81.90	PR8-460750X	93.60
.4600	.4820	1.000	.008	.150	.2100	.5000	3.0	PR8-4601000	81.90	PR8-4601000X	93.60

*Suggested Minimum Bore Diameter to accommodate chip evacuation and retract clearance in static (not live) applications.

Standard – Profiling Tools

See pgs 33-37 for standard tool holders

PA

Standard – Profiling Tools
Angled Profiling

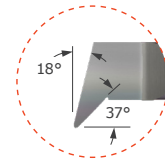
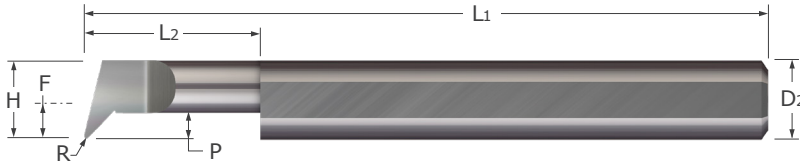

- Designed for both radial and axial profiling
- Unique design maximizes tool versatility and part feature creation
- Excellent choice for fine finishing
- Corner radius profile
- Lockdown flat automatically locates tool on center
- AlTiN coated option provides added lubricity and increased wear resistance in difficult to machine materials
- Solid carbide ■ CNC ground in the USA

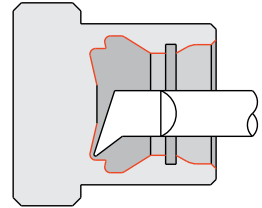

Head Width	Minimum Bore Dia.*	Maximum Bore Depth	Radius	Projection	Centerline Offset	Shank Diameter	Overall Length	Uncoated		AlTiN Coated	
								Tool #	Price	Tool #	Price
H		L2 ^{+ .030"} _{-.000"}	R ^{+ .0005"} _{-.0005"}	P	F	D2 (h6)	L1				
.0500	.0550	.150	.0020	.015	-.0125	.1250	1.5	PA2-050150	28.55	PA2-050150X	32.50
.0500	.0550	.200	.0020	.015	-.0125	.1250	1.5	PA2-050200	28.55	PA2-050200X	32.50
.0600	.0700	.150	.0020	.020	-.0025	.1250	1.5	PA2-060150	28.55	PA2-060150X	32.50
.0600	.0700	.200	.0020	.020	-.0025	.1250	1.5	PA2-060200	28.55	PA2-060200X	32.50
.0700	.0800	.150	.0020	.020	.0075	.1250	1.5	PA2-070150	27.90	PA2-070150X	31.80
.0700	.0800	.200	.0020	.020	.0075	.1250	1.5	PA2-070200	27.90	PA2-070200X	31.80
.0800	.0900	.200	.0020	.025	.0175	.1250	1.5	PA2-080200	27.90	PA2-080200X	31.80
.0800	.0900	.300	.0020	.025	.0175	.1250	1.5	PA2-080300	27.90	PA2-080300X	31.80
.0900	.1000	.200	.0020	.030	.0275	.1250	1.5	PA2-090200	27.90	PA2-090200X	31.80
.0900	.1000	.300	.0020	.030	.0275	.1250	1.5	PA2-090300	27.90	PA2-090300X	31.80
.1000	.1100	.200	.0020	.030	.0375	.1250	1.5	PA2-100200	27.90	PA2-100200X	31.80
.1000	.1100	.200	.0050	.030	.0375	.1250	1.5	PA5-100200	27.90	PA5-100200X	31.80
.1000	.1100	.300	.0020	.030	.0375	.1250	1.5	PA2-100300	27.90	PA2-100300X	31.80
.1000	.1100	.300	.0050	.030	.0375	.1250	1.5	PA5-100300	27.90	PA5-100300X	31.80
.1100	.1240	.250	.0050	.035	.0475	.1250	1.5	PA5-110250	27.90	PA5-110250X	31.80
.1100	.1240	.375	.0050	.035	.0475	.1250	1.5	PA5-110375	27.90	PA5-110375X	31.80
.1200	.1340	.250	.0050	.035	.0263	.1875	2.0	PA5-120250	29.00	PA5-120250X	33.45
.1200	.1340	.375	.0050	.035	.0263	.1875	2.0	PA5-120375	29.00	PA5-120375X	33.45
.1400	.1540	.375	.0050	.040	.0463	.1875	2.0	PA5-140375	29.00	PA5-140375X	33.45
.1400	.1540	.500	.0050	.040	.0463	.1875	2.0	PA5-140500	29.00	PA5-140500X	33.45
.1600	.1780	.375	.0050	.050	.0663	.1875	2.0	PA5-160375	29.00	PA5-160375X	33.45
.1600	.1780	.500	.0050	.050	.0663	.1875	2.0	PA5-160500	29.00	PA5-160500X	33.45
.1800	.1980	.375	.0050	.055	.0550	.2500	2.5	PA5-180375	37.15	PA5-180375X	43.20
.1800	.1980	.500	.0050	.055	.0550	.2500	2.5	PA5-180500	37.15	PA5-180500X	43.20

*Suggested Minimum Bore Diameter to accommodate chip evacuation and retract clearance in static (not live) applications.

Continued on next page

Standard – Profiling Tools

Standard – Profiling Tools

PA

Angled Profiling (cont.)

Continued from previous page

Head Width	Minimum Bore Dia.*	Maximum Bore Depth	Radius	Projection	Centerline Offset	Shank Diameter	Overall Length	Uncoated		AITIN Coated	
H		L ₂ $\begin{matrix} +.030" \\ -.000" \end{matrix}$	R $\begin{matrix} +.0005" \\ -.0005" \end{matrix}$	P	F	D ₂ (h6)	L ₁	Tool #	Price	Tool #	Price
.2000	.2180	.500	.0050	.060	.0750	.2500	2.5	PA5-200500	37.15	PA5-200500X	43.20
.2000	.2180	.500	.0080	.060	.0750	.2500	2.5	PA8-200500	37.15	PA8-200500X	43.20
.2000	.2180	.750	.0050	.060	.0750	.2500	2.5	PA5-200750	37.15	PA5-200750X	43.20
.2000	.2180	.750	.0080	.060	.0750	.2500	2.5	PA8-200750	37.15	PA8-200750X	43.20
.2300	.2520	.500	.0080	.070	.0738	.3125	2.5	PA8-230500	45.85	PA8-230500X	53.10
.2300	.2520	.750	.0080	.070	.0738	.3125	2.5	PA8-230750	45.85	PA8-230750X	53.10
.2600	.2820	.750	.0080	.080	.1038	.3125	2.5	PA8-260750	45.85	PA8-260750X	53.10
.2600	.2820	1.000	.0080	.080	.1038	.3125	2.5	PA8-2601000	45.85	PA8-2601000X	53.10
.3000	.3220	.750	.0080	.090	.1438	.3125	2.5	PA8-300750	45.85	PA8-300750X	53.10
.3000	.3220	1.000	.0080	.090	.1438	.3125	2.5	PA8-3001000	45.85	PA8-3001000X	53.10
.3600	.3820	.750	.0080	.110	.1725	.3750	2.5	PA8-360750	59.45	PA8-360750X	68.05
.3600	.3820	1.000	.0080	.110	.1725	.3750	2.5	PA8-3601000	59.45	PA8-3601000X	68.05
.4100	.4320	.750	.0080	.120	.1600	.5000	3.0	PA8-410750	83.20	PA8-410750X	94.90
.4100	.4320	1.250	.0080	.120	.1600	.5000	3.0	PA8-4101250	83.20	PA8-4101250X	94.90
.4600	.4820	.750	.0080	.140	.2100	.5000	3.0	PA8-460750	83.20	PA8-460750X	94.90
.4600	.4820	1.000	.0080	.140	.2100	.5000	3.0	PA8-4601000	83.20	PA8-4601000X	94.90

*Suggested Minimum Bore Diameter to accommodate chip evacuation and retract clearance in static (not live) applications.

Standard – Profiling Tools



Build & Send Shopping Carts Directly to Your Distributor or Purchasing Agent

Create Your Micro100 Account Today at Micro100.com

PF

Standard – Profiling Tools

Axial Profiling

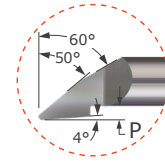
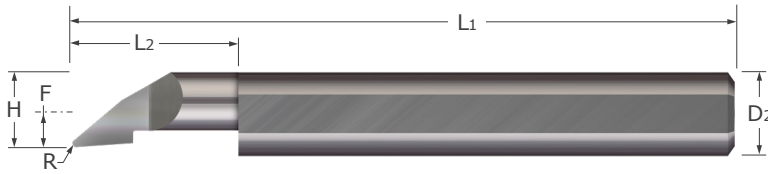

- Designed for both radial and axial profiling
- Unique design maximizes tool versatility and part feature creation
- Polished split face for improved edge retention and chip evacuation while reducing galling
- Split face geometry provides optimal edge strength
- Coolant fed enabled shank design
- Corner radius profile
- Lockdown flat automatically locates tool on center
- AlTiN coated option provides added lubricity and increased wear resistance in difficult to machine materials
- Solid carbide ■ CNC ground in the USA

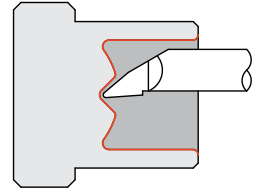

Head Width	Minimum Bore Dia.*	Maximum Bore Depth	Radius	Projection	Centerline Offset	Shank Diameter	Overall Length	Uncoated		AlTiN Coated	
								Tool #	Price	Tool #	Price
H		L2 ^{+0.050"} / _{-.000"}	R ^{+0.002"} / _{-.000"}	P	F	D2 (h6)	L1				
.0500	.0550	.150	.005	.005	-.0125	.1250	1.5	PF5-050150	28.55	PF5-050150X	32.50
.0500	.0550	.200	.005	.005	-.0125	.1250	1.5	PF5-050200	28.55	PF5-050200X	32.50
.0600	.0700	.200	.005	.005	-.0025	.1250	1.5	PF5-060200	28.55	PF5-060200X	32.50
.0600	.0700	.250	.005	.005	-.0025	.1250	1.5	PF5-060250	27.90	PF5-060250X	31.80
.0700	.0800	.200	.005	.010	.0075	.1250	1.5	PF-070200	27.90	PF-070200X	31.80
.0700	.0800	.400	.005	.010	.0075	.1250	1.5	PF-070400	27.90	PF-070400X	31.80
.0700	.0800	.500	.005	.010	.0075	.1250	1.5	PF-070500	27.90	PF-070500X	31.80
.0800	.0900	.150	.005	.010	.0175	.1250	1.5	PF5-080150	27.90	PF5-080150X	31.80
.0800	.0900	.200	.005	.010	.0175	.1250	1.5	PF5-080200	27.90	PF5-080200X	31.80
.0800	.0900	.250	.005	.010	.0175	.1250	1.5	PF5-080250	27.90	PF5-080250X	31.80
.0900	.1000	.200	.005	.010	.0275	.1250	1.5	PF5-090200	27.90	PF5-090200X	31.80
.0900	.1000	.300	.005	.010	.0275	.1250	1.5	PF5-090300	27.90	PF5-090300X	31.80
.1000	.1100	.300	.005	.015	.0375	.1250	1.5	PF5-100300	27.90	PF5-100300X	31.80
.1000	.1100	.400	.005	.015	.0375	.1250	1.5	PF5-100400	27.90	PF5-100400X	31.80
.1100	.1220	.250	.005	.015	.0475	.1250	1.5	PF-110250	27.90	PF-110250X	31.80
.1100	.1220	.375	.005	.015	.0475	.1250	1.5	PF5-110375	27.90	PF5-110375X	31.80
.1100	.1220	.500	.005	.015	.0475	.1250	1.5	PF-110500	27.90	PF-110500X	31.80
.1100	.1220	.750	.005	.015	.0475	.1250	1.5	PF-110750	27.90	PF-110750X	31.80
.1200	.1320	.250	.005	.020	.0263	.1875	2.0	PF5-120250	29.00	PF5-120250X	33.45
.1200	.1320	.250	.008	.020	.0263	.1875	2.0	PF-120250	29.00	PF-120250X	33.45
.1200	.1320	.375	.005	.020	.0263	.1875	2.0	PF5-120375	29.00	PF5-120375X	33.45
.1200	.1320	.375	.008	.020	.0263	.1875	2.0	PF8-120375	29.00	PF8-120375X	33.45
.1200	.1320	.500	.008	.020	.0263	.1875	2.0	PF-120500	29.00	PF-120500X	33.45
.1200	.1320	.750	.008	.020	.0263	.1875	2.0	PF-120750	29.00	PF-120750X	33.45
.1400	.1520	.375	.008	.020	.0463	.1875	2.0	PF8-140375	29.00	PF8-140375X	33.45
.1400	.1520	.500	.008	.020	.0463	.1875	2.0	PF8-140500	29.00	PF8-140500X	33.45

*Suggested Minimum Bore Diameter to accommodate chip evacuation and retract clearance in static (not live) applications.

Continued on next page

Standard – Profiling Tools

PF

Axial Profiling (cont.)

Continued from previous page

Head Width	Minimum Bore Dia.*	Maximum Bore Depth	Radius	Projection	Centerline Offset	Shank Diameter	Overall Length	Uncoated		AITIN Coated	
H		L ₂ ^{+0.050"} / _{-.000"}	R ^{+0.002"} / _{-.000"}	P	F	D ₂ (h6)	L ₁	Tool #	Price	Tool #	Price
.1600	.1760	.375	.008	.030	.0663	.1875	2.0	PF8-160375	29.00	PF8-160375X	33.45
.1600	.1760	.500	.008	.030	.0663	.1875	2.0	PF-160500	29.00	PF-160500X	33.45
.1600	.1760	.750	.008	.030	.0663	.1875	2.0	PF-160750	29.00	PF-160750X	33.45
.1800	.1960	.375	.008	.030	.0550	.2500	2.5	PF8-180375	37.15	PF8-180375X	43.20
.1800	.1960	.500	.008	.030	.0550	.2500	2.5	PF-180500	37.15	PF-180500X	43.20
.1800	.1960	.750	.008	.030	.0550	.2500	2.5	PF-180750	37.15	PF-180750X	43.20
.1800	.1960	1.000	.008	.030	.0550	.2500	2.5	PF-1801000	37.15	PF-1801000X	43.20
.2000	.2160	.400	.008	.030	.0750	.2500	2.5	PF8-200400	37.15	PF8-200400X	43.20
.2000	.2160	.600	.008	.030	.0750	.2500	2.5	PF-200600	37.15	PF-200600X	43.20
.2000	.2160	.800	.008	.030	.0750	.2500	2.5	PF8-200800	37.15	PF8-200800X	43.20
.2000	.2160	1.000	.008	.030	.0750	.2500	2.5	PF-2001000	37.15	PF-2001000X	43.20
.2300	.2500	.500	.008	.030	.0738	.3125	2.5	PF8-230500	45.85	PF8-230500X	53.10
.2300	.2500	.750	.008	.030	.0738	.3125	2.5	PF-230750	45.85	PF-230750X	53.10
.2300	.2500	1.000	.008	.030	.0738	.3125	2.5	PF-2301000	45.85	PF-2301000X	53.10
.2300	.2500	1.250	.008	.030	.0738	.3125	2.5	PF-2301250	45.85	PF-2301250X	53.10
.2600	.2800	.750	.008	.030	.1038	.3125	2.5	PF8-260750	45.85	PF8-260750X	53.10
.3000	.3200	1.000	.008	.030	.1438	.3125	2.5	PF-3001000	45.85	PF-3001000X	53.10
.3600	.3800	.750	.008	.030	.1725	.3750	2.5	PF8-360750	59.45	PF8-360750X	68.05
.3600	.3800	1.000	.008	.030	.1725	.3750	2.5	PF-3601000	59.45	PF-3601000X	68.05
.4100	.4300	.750	.008	.040	.1600	.5000	3.0	PF8-410750	81.90	PF8-410750X	93.60
.4100	.4300	1.000	.008	.040	.1600	.5000	3.0	PF8-4101000	81.90	PF8-4101000X	93.60
.4600	.4800	.750	.008	.050	.2100	.5000	3.0	PF8-460750	81.90	PF8-460750X	93.60
.4600	.4800	1.000	.008	.050	.2100	.5000	3.0	PF8-4601000	81.90	PF8-4601000X	93.60

*Suggested Minimum Bore Diameter to accommodate chip evacuation and retract clearance in static (not live) applications.

Standard – Profiling Tools

See pgs 33-37 for standard tool holders

MRR

Standard – Grooving Tools
Retaining Ring – Square – Right Hand – Miniature

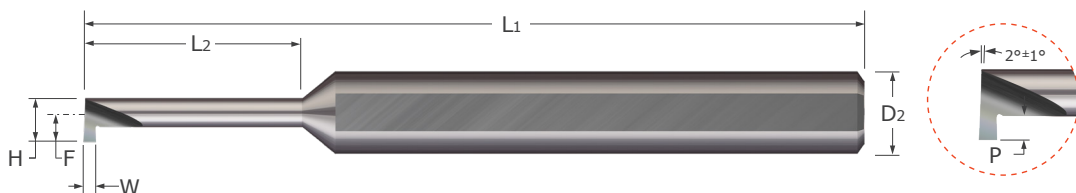

- Designed for generating retaining ring grooves in bores .070" and larger
- Polished face for improved edge retention and chip evacuation while reducing galling
- On-center neck design
- Coolant fed enabled shank design
- Sharp corner profile
- Lockdown flat automatically locates tool on center
- AlTiN coated option provides added lubricity and increased wear resistance in difficult to machine materials
- Solid carbide ■ CNC ground in the USA

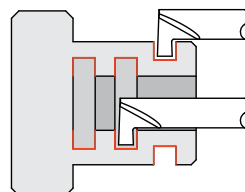

Width	Head Width	Min. Bore Diameter*	Maximum Bore Depth	Projection	Centerline Offset	Shank Diameter	Overall Length	Uncoated		AlTiN Coated	
W $\begin{smallmatrix} +.001" \\ -.000" \end{smallmatrix}$	H		L2 $\begin{smallmatrix} +.030" \\ -.000" \end{smallmatrix}$	P	F	D2 (h6)	L1	Tool #	Price	Tool #	Price
.015	.0600	.0700	.150	.020	.0400	.1250	1.5	MRR-015-150-060	32.25	MRR-015-150-060X	36.30
.015	.0600	.0700	.250	.020	.0400	.1250	1.5	MRR-015-250-060	32.25	MRR-015-250-060X	36.30
.020	.0600	.0700	.150	.020	.0400	.1250	1.5	MRR-020-150-060	32.25	MRR-020-150-060X	36.30
.020	.0600	.0700	.250	.020	.0400	.1250	1.5	MRR-020-250-060	32.25	MRR-020-250-060X	36.30
.020	.0700	.0800	.100	.020	.0450	.1250	1.5	MRR-020-100-070	32.25	MRR-020-100-070X	36.30
.020	.0700	.0800	.150	.020	.0450	.1250	1.5	MRR-020-150-070	32.25	MRR-020-150-070X	36.30
.020	.0800	.0900	.150	.025	.0525	.1250	1.5	MRR-020-150-080	32.25	MRR-020-150-080X	36.30
.020	.0800	.0900	.250	.025	.0525	.1250	1.5	MRR-020-250-080	32.25	MRR-020-250-080X	36.30
.020	.0900	.1000	.150	.025	.0575	.1250	1.5	MRR-020-150-090	32.25	MRR-020-150-090X	36.30
.020	.0900	.1000	.250	.025	.0575	.1250	1.5	MRR-020-250-090	32.25	MRR-020-250-090X	36.30
.020	.1000	.1100	.150	.030	.0650	.1875	2.0	MRR-020-150-100	34.05	MRR-020-150-100X	38.65
.020	.1000	.1100	.250	.030	.0650	.1875	2.0	MRR-020-250-100	34.05	MRR-020-250-100X	38.65
.020	.1200	.1340	.150	.040	.0800	.1875	2.0	MRR-020-150-120	34.05	MRR-020-150-120X	38.65
.020	.1200	.1340	.250	.040	.0800	.1875	2.0	MRR-020-250-120	34.05	MRR-020-250-120X	38.65
.030	.0700	.0800	.100	.020	.0450	.1250	1.5	MRR-030-100-070	32.25	MRR-030-100-070X	36.30
.030	.0700	.0800	.150	.020	.0450	.1250	1.5	MRR-030-150-070	32.25	MRR-030-150-070X	36.30
.030	.0800	.0900	.150	.025	.0525	.1250	1.5	MRR-030-150-080	32.25	MRR-030-150-080X	36.30
.030	.0800	.0900	.250	.025	.0525	.1250	1.5	MRR-030-250-080	32.25	MRR-030-250-080X	36.30
.030	.0900	.1000	.150	.025	.0575	.1250	1.5	MRR-030-150-090	32.25	MRR-030-150-090X	36.30
.030	.0900	.1000	.250	.025	.0575	.1250	1.5	MRR-030-250-090	32.25	MRR-030-250-090X	36.30
.030	.1000	.1100	.150	.030	.0650	.1875	2.0	MRR-030-150-100	34.05	MRR-030-150-100X	38.65
.030	.1000	.1100	.250	.030	.0650	.1875	2.0	MRR-030-250-100	34.05	MRR-030-250-100X	38.65
.030	.1200	.1340	.150	.040	.0800	.1875	2.0	MRR-030-150-120	34.05	MRR-030-150-120X	38.65
.030	.1200	.1340	.250	.040	.0800	.1875	2.0	MRR-030-250-120	34.05	MRR-030-250-120X	38.65

*Suggested Minimum Bore Diameter to accommodate chip evacuation and retract clearance in static (not live) applications.

Standard – Grooving Tools

Retaining Ring – Square – Right Hand

RR / RRM

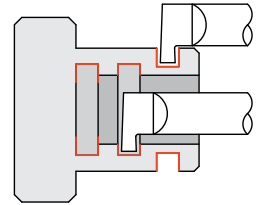
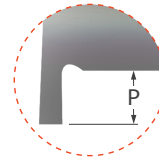
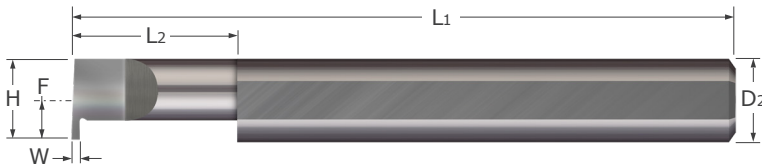

- Designed for generating retaining ring grooves
- Polished split face for improved edge retention and chip evacuation while reducing galling
- Sharp corner profile
- Lockdown flat automatically locates tool on center
- Coating options provide added lubricity and increased wear resistance in difficult to machine materials
- Solid carbide ■ CNC ground in the USA

Width	Head Width	Min. Bore Dia*	Max. Bore Depth	Proj.	Centerline Offset	Shank Dia.	OAL	Uncoated		TiN Coated		AlTiN Coated	
								Tool #	Price	Tool #	Price	Tool #	Price
W _{+0.001" dec. equiv.} -0.000" -0.025mm -0.000mm	H		L2 _{+0.050" -0.000" -0.025mm -0.000mm}	P	F	D2 (h6)	L1						
0.3 mm .0118	3 mm	3.35 mm	10 mm	0.60 mm	1.5 mm	4 mm	50 mm	RRR-030-10	30.70			RRR-030-10X	35.15
0.3 mm .0118	3 mm	3.35 mm	15 mm	0.60 mm	1.5 mm	4 mm	50 mm	RRR-030-15	30.70			RRR-030-15X	35.15
0.4 mm .0157	4 mm	4.45 mm	10 mm	0.80 mm	2 mm	4 mm	50 mm	RRR-040-10	30.70			RRR-040-10X	35.15
0.4 mm .0157	4 mm	4.45 mm	15 mm	0.80 mm	2 mm	4 mm	50 mm	RRR-040-15	30.70			RRR-040-15X	35.15
0.4 mm .0157	4 mm	4.45 mm	20 mm	0.80 mm	2 mm	4 mm	50 mm	RRR-040-20	30.70	RRR-040-20G	34.25	RRR-040-20X	35.15
.017 .0170	.187	.205	.250	.030	.0937	.1875	2.0	RR-017-250-187	33.35			RR-017-250-187X	37.85
.017 .0170	.187	.205	.375	.030	.0937	.1875	2.0	RR-017-375-187	33.35			RR-017-375-187X	37.85
.017 .0170	.187	.205	.500	.030	.0937	.1875	2.0	RR-017-500-187	33.35			RR-017-500-187X	37.85
.017 .0170	.187	.205	.625	.030	.0937	.1875	2.0	RR-017-625-187	33.35			RR-017-625-187X	37.85
.017 .0170	.250	.272	.250	.050	.1250	.2500	2.5	RR-017-4	36.35			RR-017-4X	42.40
.017 .0170	.250	.272	.375	.050	.1250	.2500	2.5	RR-017-6	36.35			RR-017-6X	42.40
.017 .0170	.250	.272	.500	.050	.1250	.2500	2.5	RR-017-8	36.35			RR-017-8X	42.40
.017 .0170	.250	.272	.625	.050	.1250	.2500	2.5	RR-017-10	36.35			RR-017-10X	42.40
0.5 mm .0200	6 mm	6.55 mm	10 mm	1.24 mm	3 mm	6 mm	57 mm	RRR-050-10	35.70	RRR-050-10G	40.85	RRR-050-10X	41.75
0.5 mm .0200	6 mm	6.55 mm	20 mm	1.24 mm	3 mm	6 mm	57 mm	RRR-050-20	35.70			RRR-050-20X	41.75
0.5 mm .0200	6 mm	6.55 mm	25 mm	1.24 mm	3 mm	6 mm	57 mm	RRR-050-25	35.70	RRR-050-25G	40.85	RRR-050-25X	41.75
.020 .0200	.120	.134	.150	.030	.0262	.1875	2.0	RR-020-150-120	33.35			RR-020-150-120X	37.85
.020 .0200	.120	.134	.250	.030	.0262	.1875	2.0	RR-020-250-120	33.35			RR-020-250-120X	37.85
.020 .0200	.140	.154	.250	.030	.0462	.1875	2.0	RR-020-250-140	33.35			RR-020-250-140X	37.85
.020 .0200	.140	.154	.375	.030	.0462	.1875	2.0	RR-020-375-140	33.35			RR-020-375-140X	37.85
.020 .0200	.160	.178	.250	.030	.0662	.1875	2.0	RR-020-250-160	33.35			RR-020-250-160X	37.85
.020 .0200	.160	.178	.375	.030	.0662	.1875	2.0	RR-020-375-160	33.35			RR-020-375-160X	37.85
.020 .0200	.187	.205	.250	.030	.0937	.1875	2.0	RR-020-250-187	33.35			RR-020-250-187X	37.85
.020 .0200	.187	.205	.375	.030	.0937	.1875	2.0	RR-020-375-187	33.35			RR-020-375-187X	37.85
.020 .0200	.187	.205	.500	.030	.0937	.1875	2.0	RR-020-500-187	33.35			RR-020-500-187X	37.85
.020 .0200	.187	.205	.625	.030	.0937	.1875	2.0	RR-020-625-187	33.35			RR-020-625-187X	37.85
.020 .0200	.250	.272	.250	.050	.1250	.2500	2.5	RR-020-250-250	36.35			RR-020-250-250X	42.40
.020 .0200	.250	.272	.375	.050	.1250	.2500	2.5	RR-020-375-250	36.35			RR-020-375-250X	42.40
.020 .0200	.250	.272	.500	.050	.1250	.2500	2.5	RR-020-500-250	36.35			RR-020-500-250X	42.40
.020 .0200	.250	.272	.625	.050	.1250	.2500	2.5	RR-020-625-250	36.35			RR-020-625-250X	42.40

*Suggested Minimum Bore Diameter to accommodate chip evacuation and retract clearance in static (not live) applications.

Continued on next page

See pgs 33-37 for standard tool holders

RR / RRM

Standard – Grooving Tools

Retaining Ring – Square – Right Hand (cont.)

Continued from previous page

Width W ₁ +.001" -.000" +.025mm -.000mm dec. equiv.	Head Width H	Min. Bore Dia* L ₂	Max. Bore Depth L ₂ +.050" -.000" +1.25mm -.00mm	Proj. P	Centerline Offset F	Shank Dia. D ₂ (h6)	OAL L ₁	Uncoated		TIN Coated		A1TiN Coated		
								Tool #	Price	Tool #	Price	Tool #	Price	
.025	.0250	.250	.272	.250	.050	.1250	.2500	2.5	RR-025-4	36.35			RR-025-4X	42.40
.025	.0250	.250	.272	.375	.050	.1250	.2500	2.5	RR-025-6	36.35			RR-025-6X	42.40
.025	.0250	.250	.272	.500	.050	.1250	.2500	2.5	RR-025-8	36.35			RR-025-8X	42.40
.025	.0250	.250	.272	.625	.050	.1250	.2500	2.5	RR-025-10	36.35			RR-025-10X	42.40
.025	.0250	.250	.272	.750	.050	.1250	.2500	2.5	RR-025-750-250	36.35			RR-025-750-250X	42.40
.025	.0250	.250	.272	1.000	.050	.1250	.2500	2.5	RR-025-1000-250	36.35			RR-025-1000-250X	42.40
0.7 mm	.0280	6 mm	6.55 mm	10 mm	1.24 mm	3 mm	6 mm	57 mm	RRM-070-10	35.70			RRM-070-10X	41.75
0.7 mm	.0280	6 mm	6.55 mm	15 mm	1.24 mm	3 mm	6 mm	57 mm	RRM-070-15	35.70				
0.7 mm	.0280	6 mm	6.55 mm	20 mm	1.24 mm	3 mm	6 mm	57 mm	RRM-070-20	35.70				
0.7 mm	.0280	6 mm	6.55 mm	25 mm	1.24 mm	3 mm	6 mm	57 mm	RRM-070-25	35.70	RRM-070-25G	40.85	RRM-070-25X	41.75
.029	.0290	.250	.272	.250	.050	.1250	.2500	2.5	RR-029-250-250	36.35			RR-029-250-250X	42.40
.029	.0290	.250	.272	.500	.050	.1250	.2500	2.5	RR-029-500-250	36.35			RR-029-500-250X	42.40
.030	.0300	.120	.134	.150	.030	.0262	.1875	2.0	RR-030-150-120	33.35			RR-030-150-120X	37.85
.030	.0300	.120	.134	.250	.030	.0262	.1875	2.0	RR-030-250-120	33.35			RR-030-250-120X	37.85
.030	.0300	.140	.154	.250	.030	.0462	.1875	2.0	RR-030-250-140	33.35			RR-030-250-140X	37.85
.030	.0300	.140	.154	.375	.030	.0462	.1875	2.0	RR-030-375-140	33.35			RR-030-375-140X	37.85
.030	.0300	.160	.178	.250	.030	.0662	.1875	2.0	RR-030-250-160	33.35			RR-030-250-160X	37.85
.030	.0300	.160	.178	.375	.030	.0662	.1875	2.0	RR-030-375-160	33.35			RR-030-375-160X	37.85
.030	.0300	.187	.205	.250	.030	.0937	.1875	2.0	RR-030-250-187	33.35			RR-030-250-187X	37.85
.030	.0300	.187	.205	.500	.030	.0937	.1875	2.0	RR-030-500-187	33.35			RR-030-500-187X	37.85
.030	.0300	.250	.272	.250	.050	.1250	.2500	2.5	RR-030-4	36.35			RR-030-4X	42.40
.030	.0300	.250	.272	.375	.050	.1250	.2500	2.5	RR-030-6	36.35			RR-030-6X	42.40
.030	.0300	.250	.272	.500	.050	.1250	.2500	2.5	RR-030-8	36.35			RR-030-8X	42.40
.030	.0300	.250	.272	.625	.050	.1250	.2500	2.5	RR-030-10	36.35			RR-030-10X	42.40
.030	.0300	.250	.272	.750	.050	.1250	.2500	2.5	RR-030-750-250	36.35			RR-030-750-250X	42.40
.030	.0300	.250	.272	1.000	.050	.1250	.2500	2.5	RR-030-1000-250	36.35			RR-030-1000-250X	42.40
.030	.0300	.312	.334	.500	.100	.1562	.3125	2.5	RR-030-500-312	45.35			RR-030-500-312X	52.60
.030	.0300	.312	.334	.750	.100	.1562	.3125	2.5	RR-030-750-312	45.35			RR-030-750-312X	52.60
.031	.0310	.250	.272	.250	.050	.1250	.2500	2.5	RR-031-250-250	36.35			RR-031-250-250X	42.40
.031	.0310	.250	.272	.500	.050	.1250	.2500	2.5	RR-031-500-250	36.35			RR-031-500-250X	42.40
0.8 mm	.0310	6 mm	6.55 mm	15 mm	1.24 mm	3 mm	6 mm	57 mm	RRM-080-15	35.70	RRM-080-15G	40.85	RRM-080-15X	41.75
0.8 mm	.0310	6 mm	6.55 mm	25 mm	1.24 mm	3 mm	6 mm	57 mm	RRM-080-25	35.70	RRM-080-25G	40.85	RRM-080-25X	41.75
.033	.0330	.312	.334	.250	.100	.1562	.3125	2.5	RR-033-4	45.35			RR-033-4X	52.60
.033	.0330	.312	.334	.375	.100	.1562	.3125	2.5	RR-033-6	45.35			RR-033-6X	52.60
.033	.0330	.312	.334	.500	.100	.1562	.3125	2.5	RR-033-8	45.35			RR-033-8X	52.60
.033	.0330	.312	.334	.750	.100	.1562	.3125	2.5	RR-033-12	45.35			RR-033-12X	52.60
.033	.0330	.312	.334	1.000	.100	.1562	.3125	2.5	RR-033-1000-312	45.35			RR-033-1000-312X	52.60
.033	.0330	.312	.334	1.250	.100	.1562	.3125	2.5	RR-033-1250-312	45.35			RR-033-1250-312X	52.60
0.9 mm	.0350	8 mm	8.55 mm	20 mm	2.50 mm	4 mm	8 mm	63 mm	RRM-090-20	43.05				
0.9 mm	.0350	8 mm	8.55 mm	30 mm	2.50 mm	4 mm	8 mm	63 mm	RRM-090-30	43.05			RRM-090-30X	51.65

*Suggested Minimum Bore Diameter to accommodate chip evacuation and retract clearance in static (not live) applications.

Continued on next page

Standard – Grooving Tools

Retaining Ring – Square – Right Hand (cont.)

RR / RRM

Continued from previous page

Width W +.001" -.000" +.025mm -.000mm dec. equiv.	Head Width H	Min. Bore Dia* L2	Max. Bore Depth L2 +.050" -.000" +.125mm -.00mm	Proj. P	Centerline Offset F	Shank Dia. D2(h6)	OAL L1	Uncoated		TiN Coated		AlTiN Coated		
								Tool #	Price	Tool #	Price	Tool #	Price	
.038	.0380	.250	.272	.250	.050	.1250	.2500	2.5	RR-038-250-250	36.35			RR-038-250-250X	42.40
.038	.0380	.250	.272	.500	.050	.1250	.2500	2.5	RR-038-500-250	36.35			RR-038-500-250X	42.40
.038	.0380	.312	.334	.250	.100	.1562	.3125	2.5	RR-038-4	45.35			RR-038-4X	52.60
.038	.0380	.312	.334	.375	.100	.1562	.3125	2.5	RR-038-6	45.35			RR-038-6X	52.60
.038	.0380	.312	.334	.500	.100	.1562	.3125	2.5	RR-038-8	45.35			RR-038-8X	52.60
.038	.0380	.312	.334	.750	.100	.1562	.3125	2.5	RR-038-12	45.35			RR-038-12X	52.60
.038	.0380	.312	.334	1.000	.100	.1562	.3125	2.5	RR-038-1000-312	45.35			RR-038-1000-312X	52.60
.038	.0380	.312	.334	1.250	.100	.1562	.3125	2.5	RR-038-1250-312	45.35			RR-038-1250-312X	52.60

Width W +.002" -.000" +.050mm -.000mm dec. equiv.	H	L2	L2 +.050" -.000" +.125mm -.00mm	P	F	D2(h6)	L1	Uncoated		TiN Coated		AlTiN Coated		
								Tool #	Price	Tool #	Price	Tool #	Price	
.039	.0390	.187	.205	.250	.030	.0937	.1875	2.0	RR-039-250-187	33.35			RR-039-250-187X	37.85
.039	.0390	.187	.205	.500	.030	.0937	.1875	2.0	RR-039-500-187	33.35			RR-039-500-187X	37.85
.039	.0390	.250	.272	.250	.050	.1250	.2500	2.5	RR-039-250-250	36.35			RR-039-250-250X	42.40
.039	.0390	.250	.272	.500	.050	.1250	.2500	2.5	RR-039-500-250	36.35			RR-039-500-250X	42.40
.039	.0390	.375	.397	.250	.100	.1875	.3750	2.5	RR-039-4	59.05			RR-039-4X	67.65
.039	.0390	.375	.397	.375	.100	.1875	.3750	2.5	RR-039-6	59.05			RR-039-6X	67.65
.039	.0390	.375	.397	.500	.100	.1875	.3750	2.5	RR-039-8	59.05			RR-039-8X	67.65
.039	.0390	.375	.397	.750	.100	.1875	.3750	2.5	RR-039-12	59.05			RR-039-12X	67.65
.039	.0390	.375	.397	1.000	.100	.1875	.3750	2.5	RR-039-16	59.05			RR-039-16X	67.65
.039	.0390	.375	.397	1.250	.100	.1875	.3750	2.5	RR-039-20	59.05			RR-039-20X	67.65
.039	.0390	.375	.397	1.500	.100	.1875	.3750	2.5	RR-039-1500-375	59.05			RR-039-1500-375X	67.65
1 mm	.0390	8 mm	8.55 mm	10 mm	2.50 mm	4 mm	8 mm	63 mm	RRM-100-10	43.05			RRM-100-10X	51.65
1 mm	.0390	8 mm	8.55 mm	20 mm	2.50 mm	4 mm	8 mm	63 mm	RRM-100-20	43.05			RRM-100-20X	51.65
1 mm	.0390	8 mm	8.55 mm	40 mm	2.50 mm	4 mm	8 mm	63 mm	RRM-100-40	43.05			RRM-100-40X	51.65
.040	.0400	.250	.272	.250	.050	.1250	.2500	2.5	RR-040-250-250	36.35			RR-040-250-250X	42.40
.040	.0400	.250	.272	.500	.050	.1250	.2500	2.5	RR-040-500-250	36.35			RR-040-500-250X	42.40
1.1 mm	.0430	8 mm	8.55 mm	10 mm	2.50 mm	4 mm	8 mm	63 mm	RRM-110-10	43.05			RRM-110-10X	51.65
1.1 mm	.0430	8 mm	8.55 mm	20 mm	2.50 mm	4 mm	8 mm	63 mm	RRM-110-20	43.05			RRM-110-20X	51.65
1.1 mm	.0430	8 mm	8.55 mm	40 mm	2.50 mm	4 mm	8 mm	63 mm	RRM-110-40	43.05			RRM-110-40X	51.65
.046	.0460	.312	.334	.500	.100	.1562	.3125	2.5	RR-046-500-312	45.35			RR-046-500-312X	52.60
.046	.0460	.312	.334	.750	.100	.1562	.3125	2.5	RR-046-750-312	45.35			RR-046-750-312X	52.60
.046	.0460	.375	.397	.250	.100	.1875	.3750	2.5	RR-046-4	59.05			RR-046-4X	67.65
.046	.0460	.375	.397	.375	.100	.1875	.3750	2.5	RR-046-6	59.05			RR-046-6X	67.65
.046	.0460	.375	.397	.500	.100	.1875	.3750	2.5	RR-046-8	59.05			RR-046-8X	67.65
.046	.0460	.375	.397	.750	.100	.1875	.3750	2.5	RR-046-12	59.05			RR-046-12X	67.65
.046	.0460	.375	.397	1.000	.100	.1875	.3750	2.5	RR-046-16	59.05			RR-046-16X	67.65
.046	.0460	.375	.397	1.250	.100	.1875	.3750	2.5	RR-046-20	59.05			RR-046-20X	67.65
1.2 mm	.0470	10 mm	10.55 mm	20 mm	2.74 mm	5 mm	10 mm	72 mm	RRM-120-20	60.55				
1.2 mm	.0470	10 mm	10.55 mm	40 mm	2.74 mm	5 mm	10 mm	72 mm	RRM-120-40	60.55	RRM-120-40G	68.50	RRM-120-40X	70.50

*Suggested Minimum Bore Diameter to accommodate chip evacuation and retract clearance in static (not live) applications.

Continued on next page

Standard – Grooving Tools

RR / RRM

Standard – Grooving Tools

Retaining Ring – Square – Right Hand (cont.)

Continued from previous page

Width W +.002" dec. -.000" equiv. +.050mm -.000mm	Head Width H	Min. Bore Dia* L1	Max. Bore Depth L2 +.050" - .000" +1.25mm - .00mm	Proj. P	Centerline Offset F	Shank Dia. D2 (h6)	OAL L1	Uncoated		TIN Coated		AlTiN Coated		
								Tool #	Price	Tool #	Price	Tool #	Price	
1.3 mm	.0510	10 mm	10.55 mm	30 mm	2.74 mm	5 mm	10 mm	72 mm	RRM-130-30	60.55				
1.3 mm	.0510	10 mm	10.55 mm	40 mm	2.74 mm	5 mm	10 mm	72 mm	RRM-130-40	60.55				
.055	.0550	.250	.272	.250	.050	.1250	.2500	2.5	RR-055-250-250	36.35			RR-055-250-250X	42.40
.055	.0550	.250	.272	.500	.050	.1250	.2500	2.5	RR-055-500-250	36.35			RR-055-500-250X	42.40
.055	.0550	.375	.397	.250	.100	.1875	.3750	2.5	RR-055-4	59.05			RR-055-4X	67.65
.055	.0550	.375	.397	.375	.100	.1875	.3750	2.5	RR-055-6	59.05			RR-055-6X	67.65
.055	.0550	.375	.397	.500	.100	.1875	.3750	2.5	RR-055-8	59.05			RR-055-8X	67.65
.055	.0550	.375	.397	.750	.100	.1875	.3750	2.5	RR-055-12	59.05			RR-055-12X	67.65
.055	.0550	.375	.397	1.000	.100	.1875	.3750	2.5	RR-055-16	59.05			RR-055-16X	67.65
.055	.0550	.375	.397	1.250	.100	.1875	.3750	2.5	RR-055-20	59.05			RR-055-20X	67.65
.055	.0550	.375	.397	1.500	.100	.1875	.3750	2.5	RR-055-1500-375	59.05			RR-055-1500-375X	67.65
.056	.0560	.250	.272	.250	.050	.1250	.2500	2.5	RR-056-250-250	36.35			RR-056-250-250X	42.40
.056	.0560	.250	.272	.500	.050	.1250	.2500	2.5	RR-056-500-250	36.35			RR-056-500-250X	42.40
.059	.0590	.375	.397	.500	.100	.1875	.3750	2.5	RR-059-500-375	59.05			RR-059-500-375X	67.65
.059	.0590	.375	.397	1.000	.100	.1875	.3750	2.5	RR-059-1000-375	59.05			RR-059-1000-375X	67.65
.062	.0620	.187	.205	.250	.030	.0937	.1875	2.0	RR-062-250-187	33.35			RR-062-250-187X	37.85
.062	.0620	.187	.205	.500	.030	.0937	.1875	2.0	RR-062-500-187	33.35			RR-062-500-187X	37.85
.062	.0620	.250	.272	.250	.050	.1250	.2500	2.5	RR-062-250-250	36.35			RR-062-250-250X	42.40
.062	.0620	.250	.272	.500	.050	.1250	.2500	2.5	RR-062-500-250	36.35			RR-062-500-250X	42.40
.062	.0620	.250	.272	.750	.050	.1250	.2500	2.5	RR-062-750-250	36.35			RR-062-750-250X	42.40
.062	.0620	.312	.334	.500	.100	.1562	.3125	2.5	RR-062-500-312	45.35			RR-062-500-312X	52.60
.062	.0620	.312	.334	.750	.100	.1562	.3125	2.5	RR-062-750-312	45.35			RR-062-750-312X	52.60
.062	.0620	.312	.334	1.000	.100	.1562	.3125	2.5	RR-062-1000-312	45.35			RR-062-1000-312X	52.60
.062	.0620	.375	.397	.250	.100	.1875	.3750	2.5	RR-062-4	59.05			RR-062-4X	67.65
.062	.0620	.375	.397	.375	.100	.1875	.3750	2.5	RR-062-6	59.05			RR-062-6X	67.65
.062	.0620	.375	.397	.500	.100	.1875	.3750	2.5	RR-062-8	59.05			RR-062-8X	67.65
.062	.0620	.375	.397	.750	.100	.1875	.3750	2.5	RR-062-12	59.05			RR-062-12X	67.65
.062	.0620	.375	.397	1.000	.100	.1875	.3750	2.5	RR-062-16	59.05			RR-062-16X	67.65
.062	.0620	.375	.397	1.250	.100	.1875	.3750	2.5	RR-062-20	59.05			RR-062-20X	67.65
.062	.0620	.375	.397	1.500	.100	.1875	.3750	2.5	RR-062-1500-375	59.05			RR-062-1500-375X	67.65
1.6 mm	.0630	10 mm	10.55 mm	30 mm	2.74 mm	5 mm	10 mm	72 mm	RRM-160-30	60.55				
1.6 mm	.0630	10 mm	10.55 mm	40 mm	2.74 mm	5 mm	10 mm	72 mm	RRM-160-40	60.55				
.069	.0690	.375	.397	.375	.100	.1875	.3750	2.5	RR-069-6	59.05			RR-069-6X	67.65
.069	.0690	.375	.397	.500	.100	.1875	.3750	2.5	RR-069-8	59.05			RR-069-8X	67.65
.069	.0690	.375	.397	.750	.100	.1875	.3750	2.5	RR-069-12	59.05			RR-069-12X	67.65
.069	.0690	.375	.397	1.000	.100	.1875	.3750	2.5	RR-069-16	59.05			RR-069-16X	67.65
.069	.0690	.375	.397	1.250	.100	.1875	.3750	2.5	RR-069-20	59.05			RR-069-20X	67.65
1.8 mm	.0710	10 mm	10.55 mm	10 mm	2.74 mm	5 mm	10 mm	72 mm	RRM-180-10	60.55	RRM-180-10G	68.50		
.079	.0790	.375	.397	.500	.100	.1875	.3750	2.5	RR-079-500-375	59.05			RR-079-500-375X	67.65
.079	.0790	.375	.397	1.000	.100	.1875	.3750	2.5	RR-079-1000-375	59.05			RR-079-1000-375X	67.65

*Suggested Minimum Bore Diameter to accommodate chip evacuation and retract clearance in static (not live) applications.

Continued on next page

Standard – Grooving Tools

RR / RRM

Retaining Ring – Square – Right Hand (cont.)

Continued from previous page

Width W ₁ + .002" dec. -.000" equiv. + .050mm -.000mm	Head Width H	Min. Bore Dia* L ₁	Max. Bore Depth L ₂ + .050" - .000" + 1.25mm - .00mm	Proj. P	Centerline Offset F	Shank Dia. D ₂ (h6)	OAL L ₁	Uncoated		TiN Coated		AlTiN Coated		
								Tool #	Price	Tool #	Price	Tool #	Price	
2 mm	.0790	10 mm	10.55 mm	20 mm	2.74 mm	5 mm	10 mm	72 mm	RRM-200-20	60.55	RRM-200-20G	68.50	RRM-200-20X	70.50
2 mm	.0790	10 mm	10.55 mm	30 mm	2.74 mm	5 mm	10 mm	72 mm	RRM-200-30	60.55	RRM-200-30G	68.50	RRM-200-30X	70.50
.087	.0870	.250	.272	.250	.050	.1250	.2500	2.5	RR-087-250-250	36.35			RR-087-250-250X	42.40
.087	.0870	.250	.272	.500	.050	.1250	.2500	2.5	RR-087-500-250	36.35			RR-087-500-250X	42.40
.087	.0870	.250	.272	.750	.050	.1250	.2500	2.5	RR-087-750-250	36.35			RR-087-750-250X	42.40
.087	.0870	.312	.334	.500	.100	.1562	.3125	2.5	RR-087-500-312	45.35			RR-087-500-312X	52.60
.087	.0870	.312	.334	.750	.100	.1562	.3125	2.5	RR-087-750-312	45.35			RR-087-750-312X	52.60
.087	.0870	.375	.397	.250	.100	.1875	.3750	2.5	RR-087-4	59.05			RR-087-4X	67.65
.087	.0870	.375	.397	.375	.100	.1875	.3750	2.5	RR-087-6	59.05			RR-087-6X	67.65
.087	.0870	.375	.397	.500	.100	.1875	.3750	2.5	RR-087-8	59.05			RR-087-8X	67.65
.087	.0870	.375	.397	.750	.100	.1875	.3750	2.5	RR-087-12	59.05			RR-087-12X	67.65
.087	.0870	.375	.397	1.000	.100	.1875	.3750	2.5	RR-087-16	59.05			RR-087-16X	67.65
.087	.0870	.375	.397	1.250	.100	.1875	.3750	2.5	RR-087-20	59.05			RR-087-20X	67.65
.087	.0870	.375	.397	1.500	.100	.1875	.3750	2.5	RR-087-1500-375	59.05			RR-087-1500-375X	67.65
.093	.0930	.375	.397	.750	.100	.1875	.3750	2.5	RR-093-750-375	59.05			RR-093-750-375X	67.65
.093	.0930	.375	.397	1.000	.100	.1875	.3750	2.5	RR-093-1000-375	59.05			RR-093-1000-375X	67.65
.093	.0930	.375	.397	1.250	.100	.1875	.3750	2.5	RR-093-1250-375	59.05			RR-093-1250-375X	67.65
.093	.0930	.500	.522	.500	.150	.2500	.5000	3.0	RR-093-8	82.80			RR-093-8X	94.50
.093	.0930	.500	.522	.750	.150	.2500	.5000	3.0	RR-093-12	82.80			RR-093-12X	94.50
.093	.0930	.500	.522	1.000	.150	.2500	.5000	3.0	RR-093-16	82.80			RR-093-16X	94.50
.093	.0930	.500	.522	1.250	.150	.2500	.5000	3.0	RR-093-20	82.80			RR-093-20X	94.50
.093	.0930	.500	.522	1.500	.150	.2500	.5000	3.0	RR-093-24	82.80			RR-093-24X	94.50
.093	.0930	.500	.522	1.750	.150	.2500	.5000	3.0	RR-093-1750-500	82.80			RR-093-1750-500X	94.50
3 mm	.1180	12 mm	12.55 mm	20 mm	3.76 mm	6 mm	12 mm	83 mm	RRM-300-20	77.60			RRM-300-20X	90.15
3 mm	.1180	12 mm	12.55 mm	30 mm	3.76 mm	6 mm	12 mm	83 mm	RRM-300-30	77.60			RRM-300-30X	90.15
3 mm	.1180	12 mm	12.55 mm	40 mm	3.76 mm	6 mm	12 mm	83 mm	RRM-300-40	77.60	RRM-300-40G	88.50	RRM-300-40X	90.15
.125	.1250	.375	.397	.750	.100	.1875	.3750	2.5	RR-125-750-375	59.05			RR-125-750-375X	67.65
.125	.1250	.375	.397	1.000	.100	.1875	.3750	2.5	RR-125-1000-375	59.05			RR-125-1000-375X	67.65
.125	.1250	.375	.397	1.250	.100	.1875	.3750	2.5	RR-125-1250-375	59.05			RR-125-1250-375X	67.65
.125	.1250	.500	.522	.500	.150	.2500	.5000	3.0	RR-125-8	82.80			RR-125-8X	94.50
.125	.1250	.500	.522	.750	.150	.2500	.5000	3.0	RR-125-12	82.80			RR-125-12X	94.50
.125	.1250	.500	.522	1.000	.150	.2500	.5000	3.0	RR-125-16	82.80			RR-125-16X	94.50
.125	.1250	.500	.522	1.250	.150	.2500	.5000	3.0	RR-125-20	82.80			RR-125-20X	94.50
.125	.1250	.500	.522	1.500	.150	.2500	.5000	3.0	RR-125-24	82.80			RR-125-24X	94.50
.125	.1250	.500	.522	1.750	.150	.2500	.5000	3.0	RR-125-1750-500	82.80			RR-125-1750-500X	94.50
.156	.1560	.500	.522	.750	.150	.2500	.5000	3.0	RR-156-12	82.80			RR-156-12X	94.50
.156	.1560	.500	.522	1.000	.150	.2500	.5000	3.0	RR-156-16	82.80			RR-156-16X	94.50
.156	.1560	.500	.522	1.250	.150	.2500	.5000	3.0	RR-156-20	82.80			RR-156-20X	94.50
.156	.1560	.500	.522	1.500	.150	.2500	.5000	3.0	RR-156-24	82.80			RR-156-24X	94.50
4 mm	.1570	12 mm	12.55 mm	20 mm	3.76 mm	6 mm	12 mm	83 mm	RRM-400-20	77.60				
4 mm	.1570	12 mm	12.55 mm	30 mm	3.76 mm	6 mm	12 mm	83 mm	RRM-400-30	77.60				
4 mm	.1570	12 mm	12.55 mm	50 mm	3.76 mm	6 mm	12 mm	83 mm	RRM-400-50	77.60	RRM-400-50G	88.50	RRM-400-50X	90.15

*Suggested Minimum Bore Diameter to accommodate chip evacuation and retract clearance in static (not live) applications.

Continued on next page

Standard – Grooving Tools

RR / RRM

Standard – Grooving Tools

Retaining Ring – Square – Right Hand (cont.)

Continued from previous page

Width W <small>+ .002" dec. -.000" equiv. + .050mm -.000mm</small>	Head Width H	Min. Bore Dia* L2 <small>+ .050" - .000" + 1.25mm - .00mm</small>	Max. Bore Depth L2	Proj. P	Centerline Offset F	Shank Dia. D2 (h6)	OAL L1	Uncoated		TiN Coated		AlTiN Coated		
								Tool #	Price	Tool #	Price	Tool #	Price	
.187	.1870	.500	.522	.750	.150	.2500	.5000	3.0	RR-187-12	82.80			RR-187-12X	94.50
.187	.1870	.500	.522	1.000	.150	.2500	.5000	3.0	RR-187-16	82.80			RR-187-16X	94.50
.187	.1870	.500	.522	1.250	.150	.2500	.5000	3.0	RR-187-20	82.80			RR-187-20X	94.50
.187	.1870	.500	.522	1.500	.150	.2500	.5000	3.0	RR-187-24	82.80			RR-187-24X	94.50
5 mm	.1970	12 mm	12.55 mm	20 mm	3.76 mm	6 mm	12 mm	83 mm	RRM-500-20	77.60				
5 mm	.1970	12 mm	12.55 mm	50 mm	3.76 mm	6 mm	12 mm	83 mm	RRM-500-50	77.60			RRM-500-50X	90.15
6 mm	.2360	12 mm	12.55 mm	20 mm	3.76 mm	6 mm	12 mm	83 mm	RRM-600-20	77.60				
6 mm	.2360	12 mm	12.55 mm	50 mm	3.76 mm	6 mm	12 mm	83 mm	RRM-600-50	77.60				
.250	.2500	.500	.522	.750	.150	.2500	.5000	3.0	RR-250-12	82.80			RR-250-12X	94.50
.250	.2500	.500	.522	1.000	.150	.2500	.5000	3.0	RR-250-16	82.80			RR-250-16X	94.50
.250	.2500	.500	.522	1.250	.150	.2500	.5000	3.0	RR-250-20	82.80			RR-250-20X	94.50
.250	.2500	.500	.522	1.500	.150	.2500	.5000	3.0	RR-250-24	82.80			RR-250-24X	94.50

*Suggested Minimum Bore Diameter to accommodate chip evacuation and retract clearance in static (not live) applications.



Find the Perfect Micro 100 Tool For Your Next Job With Product Table Filtering

On Micro100.com

Standard - Grooving Tools

Retaining Ring - Square - Left Hand

RRL

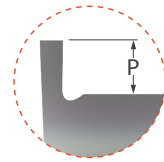
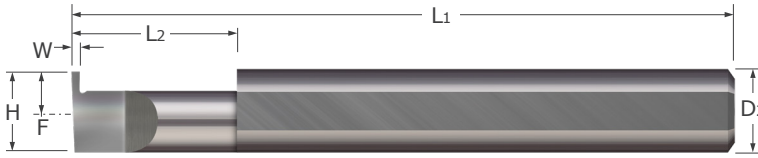

- Designed for generating retaining ring grooves in a left hand turning application
- Polished split face for improved edge retention and chip evacuation while reducing galling
- Sharp corner profile
- Lockdown flat automatically locates tool on center
- AlTiN coated option provides added lubricity and increased wear resistance in difficult to machine materials
- Solid carbide ■ CNC ground in the USA

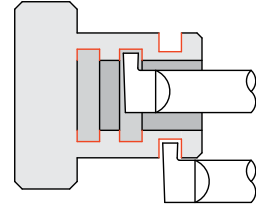

Standard - Grooving Tools

Width	Head Width	Minimum Bore Diameter*	Maximum Bore Depth	Projection	Centerline Offset	Shank Diameter	Overall Length	Uncoated		AlTiN Coated	
								Tool #	Price	Tool #	Price
W $\begin{smallmatrix} +.001" \\ -.000" \end{smallmatrix}$	H		L2 $\begin{smallmatrix} +.050" \\ -.000" \end{smallmatrix}$	P	F	D2 (h6)	L1				
.017	.250	.272	.250	.050	.1250	.2500	2.5	RRL-017-4	36.35	RRL-017-4X	42.40
.017	.250	.272	.500	.050	.1250	.2500	2.5	RRL-017-8	36.35	RRL-017-8X	42.40
.025	.250	.272	.250	.050	.1250	.2500	2.5	RRL-025-4	36.35	RRL-025-4X	42.40
.025	.250	.272	.500	.050	.1250	.2500	2.5	RRL-025-8	36.35	RRL-025-8X	42.40
.030	.250	.272	.250	.050	.1250	.2500	2.5	RRL-030-4	36.35	RRL-030-4X	42.40
.030	.250	.272	.375	.050	.1250	.2500	2.5	RRL-030-6	36.35	RRL-030-6X	42.40
.030	.250	.272	.500	.050	.1250	.2500	2.5	RRL-030-8	36.35	RRL-030-8X	42.40
.030	.250	.272	.625	.050	.1250	.2500	2.5	RRL-030-10	36.35	RRL-030-10X	42.40
.033	.312	.334	.250	.100	.1562	.3125	2.5	RRL-033-4	45.35	RRL-033-4X	52.60
.033	.312	.334	.375	.100	.1562	.3125	2.5	RRL-033-6	45.35		
.033	.312	.334	.750	.100	.1562	.3125	2.5	RRL-033-12	45.35		
.038	.312	.334	.250	.100	.1562	.3125	2.5	RRL-038-4	45.35		
.038	.312	.334	.375	.100	.1562	.3125	2.5	RRL-038-6	45.35		
.038	.312	.334	.500	.100	.1562	.3125	2.5	RRL-038-8	45.35	RRL-038-8X	52.60
.038	.312	.334	.750	.100	.1562	.3125	2.5	RRL-038-12	45.35	RRL-038-12X	52.60

.039	.375	.397	.250	.100	.1875	.3750	2.5	RRL-039-4	59.05	RRL-039-4X	67.65
.039	.375	.397	.500	.100	.1875	.3750	2.5	RRL-039-8	59.05	RRL-039-8X	67.65
.039	.375	.397	.750	.100	.1875	.3750	2.5	RRL-039-12	59.05		
.046	.375	.397	.250	.100	.1875	.3750	2.5	RRL-046-4	59.05	RRL-046-4X	67.65
.046	.375	.397	.375	.100	.1875	.3750	2.5	RRL-046-6	59.05		
.046	.375	.397	.750	.100	.1875	.3750	2.5	RRL-046-12	59.05	RRL-046-12X	67.65
.046	.375	.397	1.000	.100	.1875	.3750	2.5	RRL-046-16	59.05	RRL-046-16X	67.65
.046	.375	.397	1.250	.100	.1875	.3750	2.5	RRL-046-20	59.05	RRL-046-20X	67.65
.055	.375	.397	.250	.100	.1875	.3750	2.5	RRL-055-4	59.05		
.055	.375	.397	.500	.100	.1875	.3750	2.5	RRL-055-8	59.05		
.055	.375	.397	.750	.100	.1875	.3750	2.5	RRL-055-12	59.05		
.055	.375	.397	1.000	.100	.1875	.3750	2.5	RRL-055-16	59.05		

*Suggested Minimum Bore Diameter to accommodate chip evacuation and retract clearance in static (not live) applications.

Continued on next page

See pgs 33-37 for standard tool holders

RRL

Standard – Grooving Tools
Retaining Ring – Left Hand (cont.)

Continued from previous page

Width W $\begin{smallmatrix} +.002" \\ -.000" \end{smallmatrix}$	Head Width H	Minimum Bore Diameter*	Maximum Bore Depth L2 $\begin{smallmatrix} +.050" \\ -.000" \end{smallmatrix}$	Projection P	Centerline Offset F	Shank Diameter D2 (h6)	Overall Length L1	Uncoated		AITIN Coated	
								Tool #	Price	Tool #	Price
.062	.375	.397	.250	.100	.1875	.3750	2.5	RRL-062-4	59.05		
.062	.375	.397	.500	.100	.1875	.3750	2.5	RRL-062-8	59.05	RRL-062-8X	67.65
.062	.375	.397	.750	.100	.1875	.3750	2.5	RRL-062-12	59.05	RRL-062-12X	67.65
.062	.375	.397	1.250	.100	.1875	.3750	2.5	RRL-062-20	59.05	RRL-062-20X	67.65
.069	.375	.397	.250	.100	.1875	.3750	2.5	RRL-069-4	59.05		
.069	.375	.397	.500	.100	.1875	.3750	2.5	RRL-069-8	59.05		
.069	.375	.397	1.000	.100	.1875	.3750	2.5	RRL-069-16	59.05	RRL-069-16X	67.65
.069	.375	.397	1.250	.100	.1875	.3750	2.5	RRL-069-20	59.05		
.087	.375	.397	.375	.100	.1875	.3750	2.5	RRL-087-6	59.05		
.087	.375	.397	.500	.100	.1875	.3750	2.5	RRL-087-8	59.05	RRL-087-8X	67.65
.087	.375	.397	.750	.100	.1875	.3750	2.5	RRL-087-12	59.05	RRL-087-12X	67.65
.087	.375	.397	1.000	.100	.1875	.3750	2.5	RRL-087-16	59.05		
.087	.375	.397	1.250	.100	.1875	.3750	2.5	RRL-087-20	59.05	RRL-087-20X	67.65
.093	.500	.522	.750	.150	.2500	.5000	3.0	RRL-093-12	82.80	RRL-093-12X	94.50
.093	.500	.522	1.000	.150	.2500	.5000	3.0	RRL-093-16	82.80	RRL-093-16X	94.50
.093	.500	.522	1.500	.150	.2500	.5000	3.0	RRL-093-24	82.80	RRL-093-24X	94.50
.125	.500	.522	.500	.150	.2500	.5000	3.0	RRL-125-8	82.80	RRL-125-8X	94.50
.125	.500	.522	.750	.150	.2500	.5000	3.0	RRL-125-12	82.80		
.125	.500	.522	1.000	.150	.2500	.5000	3.0	RRL-125-16	82.80		
.125	.500	.522	1.500	.150	.2500	.5000	3.0	RRL-125-24	82.80	RRL-125-24X	94.50
.156	.500	.522	.500	.150	.2500	.5000	3.0	RRL-156-8	82.80		
.187	.500	.522	.750	.150	.2500	.5000	3.0	RRL-187-12	82.80		
.187	.500	.522	1.000	.150	.2500	.5000	3.0	RRL-187-16	82.80		
.187	.500	.522	1.250	.150	.2500	.5000	3.0	RRL-187-20	82.80		
.250	.500	.522	.500	.150	.2500	.5000	3.0	RRL-250-8	82.80		
.250	.500	.522	.750	.150	.2500	.5000	3.0	RRL-250-12	82.80		
.250	.500	.522	1.000	.150	.2500	.5000	3.0	RRL-250-16	82.80		
.250	.500	.522	1.250	.150	.2500	.5000	3.0	RRL-250-20	82.80		

*Suggested Minimum Bore Diameter to accommodate chip evacuation and retract clearance in static (not live) applications.

Standard – Grooving Tools

Standard – Grooving Tools

RRC

Retaining Ring – Corner Radius – Right Hand

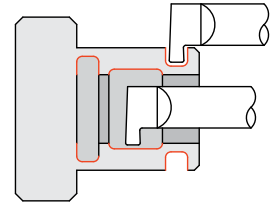
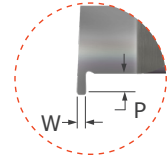
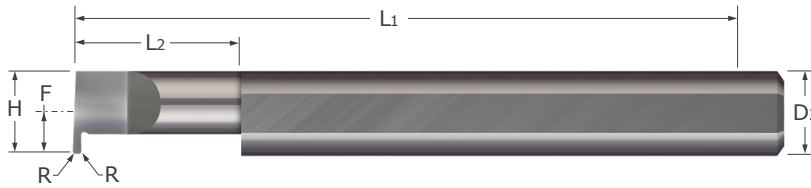

- Designed for generating corner radius retaining ring grooves in bores .205" and larger
- Corner radius designed for extended tool life, and finished groove profiling
- Polished split face for improved edge retention and chip evacuation while reducing galling
- Coolant fed enabled shank design
- Lockdown flat automatically locates tool on center
- AlTiN coated option provides added lubricity and increased wear resistance in difficult to machine materials
- Solid carbide ■ CNC ground in the USA

Width	Head Width	Minimum Bore Diameter*	Maximum Bore Depth	Radius	Projection	Centerline Offset	Shank Diameter	Overall Length	Uncoated		AlTiN Coated	
									Tool #	Price	Tool #	Price
W $^{+.001"}$ $_{-.000"}$	H		L2 $^{+.050"}$ $_{-.000"}$	R $^{+.001"}$ $_{-.001"}$	P	F	D2 (h6)	L1	Tool #	Price	Tool #	Price
.017	.187	.205	.250	.003	.030	.0937	.1875	2.0	RRC3-017-250-187	38.75	RRC3-017-250-187X	43.45
.017	.187	.205	.375	.003	.030	.0937	.1875	2.0	RRC3-017-375-187	38.75	RRC3-017-375-187X	43.45
.017	.250	.272	.250	.003	.050	.1250	.2500	2.5	RRC3-017-250-250	41.75	RRC3-017-250-250X	47.80
.017	.250	.272	.375	.003	.050	.1250	.2500	2.5	RRC3-017-375-250	41.75	RRC3-017-375-250X	47.80
.020	.187	.205	.250	.003	.030	.0937	.1875	2.0	RRC3-020-250-187	38.75	RRC3-020-250-187X	43.45
.020	.187	.205	.375	.003	.030	.0937	.1875	2.0	RRC3-020-375-187	38.75	RRC3-020-375-187X	43.45
.020	.250	.272	.250	.003	.050	.1250	.2500	2.5	RRC3-020-250-250	41.75	RRC3-020-250-250X	47.80
.020	.250	.272	.375	.003	.050	.1250	.2500	2.5	RRC3-020-375-250	41.75	RRC3-020-375-250X	47.80
.025	.250	.272	.250	.003	.050	.1250	.2500	2.5	RRC3-025-250-250	41.75	RRC3-025-250-250X	47.80
.025	.250	.272	.375	.003	.050	.1250	.2500	2.5	RRC3-025-375-250	41.75	RRC3-025-375-250X	47.80
.030	.187	.205	.250	.003	.030	.0937	.1875	2.0	RRC3-030-250-187	38.75	RRC3-030-250-187X	43.45
.030	.187	.205	.500	.003	.030	.0937	.1875	2.0	RRC3-030-500-187	38.75	RRC3-030-500-187X	43.45
.030	.250	.272	.250	.003	.050	.1250	.2500	2.5	RRC3-030-250-250	41.75	RRC3-030-250-250X	47.80
.030	.250	.272	.375	.003	.050	.1250	.2500	2.5	RRC3-030-375-250	41.75	RRC3-030-375-250X	47.80
.030	.312	.334	.500	.003	.100	.1562	.3125	2.5	RRC3-030-500-312	52.10	RRC3-030-500-312X	59.35
.030	.312	.334	.750	.003	.100	.1562	.3125	2.5	RRC3-030-750-312	52.10	RRC3-030-750-312X	59.35
.033	.312	.334	.500	.003	.100	.1562	.3125	2.5	RRC3-033-500-312	52.10	RRC3-033-500-312X	59.35
.033	.312	.334	.750	.003	.100	.1562	.3125	2.5	RRC3-033-750-312	52.10	RRC3-033-750-312X	59.35
.038	.312	.334	.500	.003	.100	.1562	.3125	2.5	RRC3-038-500-312	52.10	RRC3-038-500-312X	59.35
.038	.312	.334	.750	.003	.100	.1562	.3125	2.5	RRC3-038-750-312	52.10	RRC3-038-750-312X	59.35
W $^{+.002"}$ $_{-.000"}$	H		L2 $^{+.050"}$ $_{-.000"}$	R $^{+.001"}$ $_{-.001"}$	P	F	D2 (h6)	L1	Tool #	Price	Tool #	Price
.039	.375	.397	.500	.003	.100	.1875	.3750	2.5	RRC3-039-500-375	66.00	RRC3-039-500-375X	74.60
.039	.375	.397	.750	.003	.100	.1875	.3750	2.5	RRC3-039-750-375	66.00	RRC3-039-750-375X	74.60
.039	.375	.397	1.000	.003	.100	.1875	.3750	2.5	RRC3-039-1000-375	66.00	RRC3-039-1000-375X	74.60
.062	.375	.397	.500	.003	.100	.1875	.3750	2.5	RRC3-062-500-375	66.00	RRC3-062-500-375X	74.60
.062	.375	.397	.500	.006	.100	.1875	.3750	2.5	RRC6-062-500-375	66.00	RRC6-062-500-375X	74.60
.062	.375	.397	.750	.003	.100	.1875	.3750	2.5	RRC3-062-750-375	66.00	RRC3-062-750-375X	74.60

*Suggested Minimum Bore Diameter to accommodate chip evacuation and retract clearance in static (not live) applications.

Continued on next page

RRC

Standard – Grooving Tools

Retaining Ring – Corner Radius – Right Hand (cont.)

Continued from previous page

Width W $\begin{smallmatrix} +.002" \\ -.000" \end{smallmatrix}$	Head Width H	Minimum Bore Diameter*	Maximum Bore Depth L2 $\begin{smallmatrix} +.050" \\ -.000" \end{smallmatrix}$	Radius R $\begin{smallmatrix} +.001" \\ -.001" \end{smallmatrix}$	Projection P	Centerline Offset F	Shank Diameter D2 (h6)	Overall Length L1	Uncoated		AlTiN Coated	
									Tool #	Price	Tool #	Price
.062	.375	.397	.750	.006	.100	.1875	.3750	2.5	RRC6-062-750-375	66.00	RRC6-062-750-375X	74.60
.062	.375	.397	1.000	.003	.100	.1875	.3750	2.5	RRC3-062-1000-375	66.00	RRC3-062-1000-375X	74.60
.062	.375	.397	1.000	.006	.100	.1875	.3750	2.5	RRC6-062-1000-375	66.00	RRC6-062-1000-375X	74.60
.087	.375	.397	.500	.003	.100	.1875	.3750	2.5	RRC3-087-500-375	66.00	RRC3-087-500-375X	74.60
.087	.375	.397	.500	.006	.100	.1875	.3750	2.5	RRC6-087-500-375	66.00	RRC6-087-500-375X	74.60
.087	.375	.397	.750	.003	.100	.1875	.3750	2.5	RRC3-087-750-375	66.00	RRC3-087-750-375X	74.60
.087	.375	.397	.750	.006	.100	.1875	.3750	2.5	RRC6-087-750-375	66.00	RRC6-087-750-375X	74.60
.087	.375	.397	1.000	.003	.100	.1875	.3750	2.5	RRC3-087-1000-375	66.00	RRC3-087-1000-375X	74.60
.087	.375	.397	1.000	.006	.100	.1875	.3750	2.5	RRC6-087-1000-375	66.00	RRC6-087-1000-375X	74.60
.093	.500	.522	.750	.003	.150	.2500	.5000	3.0	RRC3-093-750-500	90.70	RRC3-093-750-500X	102.40
.093	.500	.522	.750	.006	.150	.2500	.5000	3.0	RRC6-093-750-500	90.70	RRC6-093-750-500X	102.40
.093	.500	.522	1.000	.003	.150	.2500	.5000	3.0	RRC3-093-1000-500	90.70	RRC3-093-1000-500X	102.40
.093	.500	.522	1.000	.006	.150	.2500	.5000	3.0	RRC6-093-1000-500	90.70	RRC6-093-1000-500X	102.40
.125	.500	.522	.750	.003	.150	.2500	.5000	3.0	RRC3-125-750-500	90.70	RRC3-125-750-500X	102.40
.125	.500	.522	.750	.006	.150	.2500	.5000	3.0	RRC6-125-750-500	90.70	RRC6-125-750-500X	102.40
.125	.500	.522	1.000	.003	.150	.2500	.5000	3.0	RRC3-125-1000-500	90.70	RRC3-125-1000-500X	102.40
.125	.500	.522	1.000	.006	.150	.2500	.5000	3.0	RRC6-125-1000-500	90.70	RRC6-125-1000-500X	102.40

*Suggested Minimum Bore Diameter to accommodate chip evacuation and retract clearance in static (not live) applications.

Standard – Grooving Tools

FR

Full Radius

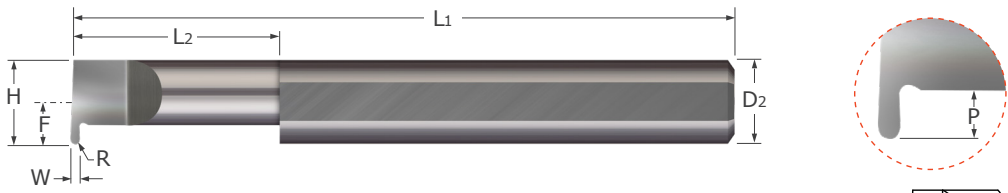

- Designed for generating full radius grooves
- Polished split face for improved edge retention and chip evacuation while reducing galling
- Full radius profile
- Lockdown flat automatically locates tool on center
- AlTiN coated option provides added lubricity and increased wear resistance in difficult to machine materials
- Solid carbide ■ CNC ground in the USA

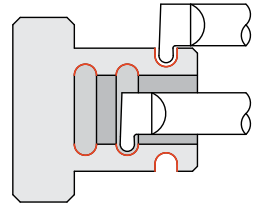

Standard – Grooving Tools

Width	Radius	Head Width	Min. Bore Dia*	Max. Bore Depth	Proj.	Centerline Offset	Shank Diameter	Overall Length	Uncoated		AlTiN Coated	
									Tool #	Price	Tool #	Price
W $^{+.002"}_{-.000"}$	R	H	L2 $^{+.050"}_{-.000"}$	P	F	D2 (h6)	L1	Tool #	Price	Tool #	Price	
.017	.0085	.187	.205	.250	.030	.0937	.1875	2.0	FR-017-4-187	38.75	FR-017-4-187X	43.45
.017	.0085	.187	.205	.375	.030	.0937	.1875	2.0	FR-017-6-187	38.75	FR-017-6-187X	43.45
.017	.0085	.187	.205	.500	.030	.0937	.1875	2.0	FR-017-8-187	38.75	FR-017-8-187X	43.45
.017	.0085	.187	.205	.625	.030	.0937	.1875	2.0	FR-017-10-187	38.75	FR-017-10-187X	43.45
.017	.0085	.250	.272	.250	.050	.1250	.2500	2.5	FR-017-4	41.75	FR-017-4X	47.80
.017	.0085	.250	.272	.375	.050	.1250	.2500	2.5	FR-017-6	41.75	FR-017-6X	47.80
.017	.0085	.250	.272	.500	.050	.1250	.2500	2.5	FR-017-8	41.75	FR-017-8X	47.80
.017	.0085	.250	.272	.625	.050	.1250	.2500	2.5	FR-017-10	41.75	FR-017-10X	47.80
.020	.0100	.187	.205	.250	.030	.0937	.1875	2.0	FR-020-4-187	38.75	FR-020-4-187X	43.45
.020	.0100	.187	.205	.375	.030	.0937	.1875	2.0	FR-020-6-187	38.75	FR-020-6-187X	43.45
.020	.0100	.187	.205	.500	.030	.0937	.1875	2.0	FR-020-8-187	38.75	FR-020-8-187X	43.45
.020	.0100	.187	.205	.625	.030	.0937	.1875	2.0	FR-020-10-187	38.75	FR-020-10-187X	43.45
.025	.0125	.250	.272	.250	.050	.1250	.2500	2.5	FR-025-4	41.75	FR-025-4X	47.80
.025	.0125	.250	.272	.375	.050	.1250	.2500	2.5	FR-025-6	41.75	FR-025-6X	47.80
.025	.0125	.250	.272	.500	.050	.1250	.2500	2.5	FR-025-8	41.75	FR-025-8X	47.80
.025	.0125	.250	.272	.625	.050	.1250	.2500	2.5	FR-025-10	41.75	FR-025-10X	47.80
.030	.0150	.250	.272	.250	.050	.1250	.2500	2.5	FR-030-4	41.75	FR-030-4X	47.80
.030	.0150	.250	.272	.375	.050	.1250	.2500	2.5	FR-030-6	41.75	FR-030-6X	47.80
.030	.0150	.250	.272	.500	.050	.1250	.2500	2.5	FR-030-8	41.75	FR-030-8X	47.80
.030	.0150	.250	.272	.625	.050	.1250	.2500	2.5	FR-030-10	41.75	FR-030-10X	47.80
.033	.0165	.312	.334	.250	.100	.1562	.3125	2.5	FR-033-4	52.10	FR-033-4X	59.35
.033	.0165	.312	.334	.375	.100	.1562	.3125	2.5	FR-033-6	52.10	FR-033-6X	59.35
.033	.0165	.312	.334	.500	.100	.1562	.3125	2.5	FR-033-8	52.10	FR-033-8X	59.35
.033	.0165	.312	.334	.625	.100	.1562	.3125	2.5	FR-033-10	52.10	FR-033-10X	59.35
.038	.0190	.312	.334	.250	.100	.1562	.3125	2.5	FR-038-4	52.10	FR-038-4X	59.35
.038	.0190	.312	.334	.375	.100	.1562	.3125	2.5	FR-038-6	52.10	FR-038-6X	59.35
.038	.0190	.312	.334	.500	.100	.1562	.3125	2.5	FR-038-8	52.10	FR-038-8X	59.35
.038	.0190	.312	.334	.625	.100	.1562	.3125	2.5	FR-038-10	52.10	FR-038-10X	59.35
.039	.0195	.375	.397	.250	.100	.1875	.3750	2.5	FR-039-4	66.00	FR-039-4X	74.60
.039	.0195	.375	.397	.375	.100	.1875	.3750	2.5	FR-039-6	66.00	FR-039-6X	74.60
.039	.0195	.375	.397	.500	.100	.1875	.3750	2.5	FR-039-8	66.00	FR-039-8X	74.60
.039	.0195	.375	.397	.750	.100	.1875	.3750	2.5	FR-039-12	66.00	FR-039-12X	74.60
.039	.0195	.375	.397	1.000	.100	.1875	.3750	2.5	FR-039-16	66.00	FR-039-16X	74.60
.039	.0195	.375	.397	1.250	.100	.1875	.3750	2.5	FR-039-20	66.00	FR-039-20X	74.60

*Suggested Minimum Bore Diameter to accommodate chip evacuation and retract clearance in static (not live) applications.

Continued on next page

FR

Standard - Grooving Tools

Full Radius (cont.)

Continued from previous page

W	Radius	Head Width	Min. Bore Dia*	Max. Bore Depth	Proj.	Centerline Offset	Shank Diameter	Overall Length	Uncoated		AITIN Coated	
									Tool #	Price	Tool #	Price
$W \begin{matrix} +.002" \\ -.000" \end{matrix}$	R	H		$L_2 \begin{matrix} +.050" \\ -.000" \end{matrix}$	P	F	D2 (h6)	L1				
.046	.0230	.375	.397	.250	.100	.1875	.3750	2.5	FR-046-4	66.00	FR-046-4X	74.60
.046	.0230	.375	.397	.375	.100	.1875	.3750	2.5	FR-046-6	66.00	FR-046-6X	74.60
.046	.0230	.375	.397	.500	.100	.1875	.3750	2.5	FR-046-8	66.00	FR-046-8X	74.60
.046	.0230	.375	.397	.750	.100	.1875	.3750	2.5	FR-046-12	66.00	FR-046-12X	74.60
.046	.0230	.375	.397	1.000	.100	.1875	.3750	2.5	FR-046-16	66.00	FR-046-16X	74.60
.046	.0230	.375	.397	1.250	.100	.1875	.3750	2.5	FR-046-20	66.00	FR-046-20X	74.60
.055	.0275	.375	.397	.250	.100	.1875	.3750	2.5	FR-055-4	66.00	FR-055-4X	74.60
.055	.0275	.375	.397	.375	.100	.1875	.3750	2.5	FR-055-6	66.00	FR-055-6X	74.60
.055	.0275	.375	.397	.500	.100	.1875	.3750	2.5	FR-055-8	66.00	FR-055-8X	74.60
.055	.0275	.375	.397	.750	.100	.1875	.3750	2.5	FR-055-12	66.00	FR-055-12X	74.60
.055	.0275	.375	.397	1.000	.100	.1875	.3750	2.5	FR-055-16	66.00	FR-055-16X	74.60
.055	.0275	.375	.397	1.250	.100	.1875	.3750	2.5	FR-055-20	66.00	FR-055-20X	74.60
.062	.0310	.375	.397	.250	.100	.1875	.3750	2.5	FR-062-4	66.00	FR-062-4X	74.60
.062	.0310	.375	.397	.375	.100	.1875	.3750	2.5	FR-062-6	66.00	FR-062-6X	74.60
.062	.0310	.375	.397	.500	.100	.1875	.3750	2.5	FR-062-8	66.00	FR-062-8X	74.60
.062	.0310	.375	.397	.750	.100	.1875	.3750	2.5	FR-062-12	66.00	FR-062-12X	74.60
.062	.0310	.375	.397	1.000	.100	.1875	.3750	2.5	FR-062-16	66.00	FR-062-16X	74.60
.062	.0310	.375	.397	1.250	.100	.1875	.3750	2.5	FR-062-20	66.00	FR-062-20X	74.60
.069	.0345	.375	.397	.250	.100	.1875	.3750	2.5	FR-069-4	66.00	FR-069-4X	74.60
.069	.0345	.375	.397	.375	.100	.1875	.3750	2.5	FR-069-6	66.00	FR-069-6X	74.60
.069	.0345	.375	.397	.500	.100	.1875	.3750	2.5	FR-069-8	66.00	FR-069-8X	74.60
.069	.0345	.375	.397	.750	.100	.1875	.3750	2.5	FR-069-12	66.00	FR-069-12X	74.60
.069	.0345	.375	.397	1.000	.100	.1875	.3750	2.5	FR-069-16	66.00	FR-069-16X	74.60
.069	.0345	.375	.397	1.250	.100	.1875	.3750	2.5	FR-069-20	66.00	FR-069-20X	74.60
.087	.0435	.375	.397	.250	.100	.1875	.3750	2.5	FR-087-4	66.00	FR-087-4X	74.60
.087	.0435	.375	.397	.375	.100	.1875	.3750	2.5	FR-087-6	66.00	FR-087-6X	74.60
.087	.0435	.375	.397	.500	.100	.1875	.3750	2.5	FR-087-8	66.00	FR-087-8X	74.60
.087	.0435	.375	.397	.750	.100	.1875	.3750	2.5	FR-087-12	66.00	FR-087-12X	74.60
.087	.0435	.375	.397	1.000	.100	.1875	.3750	2.5	FR-087-16	66.00	FR-087-16X	74.60
.087	.0435	.375	.397	1.250	.100	.1875	.3750	2.5	FR-087-20	66.00	FR-087-20X	74.60
.093	.0465	.500	.522	.500	.150	.2500	.5000	3.0	FR-093-8	90.70	FR-093-8X	102.40
.093	.0465	.500	.522	.750	.150	.2500	.5000	3.0	FR-093-12	90.70	FR-093-12X	102.40
.093	.0465	.500	.522	1.000	.150	.2500	.5000	3.0	FR-093-16	90.70	FR-093-16X	102.40
.093	.0465	.500	.522	1.250	.150	.2500	.5000	3.0	FR-093-20	90.70	FR-093-20X	102.40
.093	.0465	.500	.522	1.500	.150	.2500	.5000	3.0	FR-093-24	90.70	FR-093-24X	102.40
.125	.0625	.500	.522	.500	.150	.2500	.5000	3.0	FR-125-8	90.70	FR-125-8X	102.40
.125	.0625	.500	.522	.750	.150	.2500	.5000	3.0	FR-125-12	90.70	FR-125-12X	102.40
.125	.0625	.500	.522	1.000	.150	.2500	.5000	3.0	FR-125-16	90.70	FR-125-16X	102.40
.125	.0625	.500	.522	1.250	.150	.2500	.5000	3.0	FR-125-20	90.70	FR-125-20X	102.40
.125	.0625	.500	.522	1.500	.150	.2500	.5000	3.0	FR-125-24	90.70	FR-125-24X	102.40
.187	.0935	.500	.522	.500	.150	.2500	.5000	3.0	FR-187-8	90.70	FR-187-8X	102.40
.187	.0935	.500	.522	.750	.150	.2500	.5000	3.0	FR-187-12	90.70	FR-187-12X	102.40
.187	.0935	.500	.522	1.000	.150	.2500	.5000	3.0	FR-187-16	90.70	FR-187-16X	102.40
.187	.0935	.500	.522	1.250	.150	.2500	.5000	3.0	FR-187-20	90.70	FR-187-20X	102.40
.187	.0935	.500	.522	1.500	.150	.2500	.5000	3.0	FR-187-24	90.70	FR-187-24X	102.40

*Suggested Minimum Bore Diameter to accommodate chip evacuation and retract clearance in static (not live) applications.



Standard – Grooving Tools

UC

Undercutting – Square

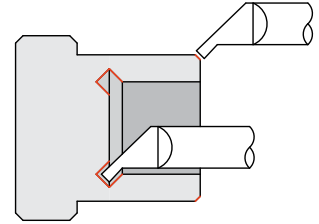
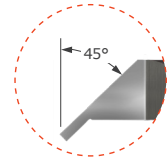
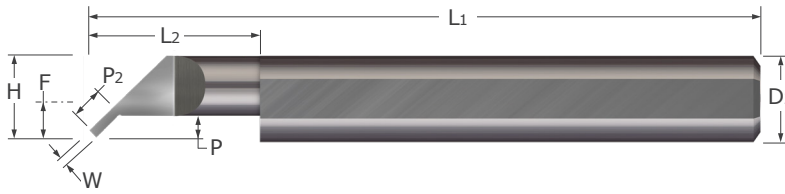

- Designed for plunging square undercut grooves
- Polished split face for improved edge retention and chip evacuation while reducing galling
- Sharp corner profile
- Lockdown flat automatically locates tool on center
- AlTiN coated option provides added lubricity and increased wear resistance in difficult to machine materials
- Solid carbide ■ CNC ground in the USA

Width	Projection	Angled Projection	Head Width	Minimum Bore Diameter*	Maximum Bore Depth	Centerline Offset	Shank Diameter	Overall Length	Uncoated		AlTiN Coated	
W $\begin{smallmatrix} +.002" \\ -.000" \end{smallmatrix}$	P	P ₂	H		L ₂ $\begin{smallmatrix} +.050" \\ -.000" \end{smallmatrix}$	F	D ₂ (h6)	L ₁	Tool #	Price	Tool #	Price
.030	.060	.080	.240	.262	.500	.1150	.2500	2.5	UC-25030-8	37.70	UC-25030-8X	43.75
.050	.083	.120	.303	.325	.500	.1468	.3125	2.5	UC-31050-8	46.95	UC-31050-8X	54.20
.062	.083	.120	.303	.325	1.000	.1468	.3125	2.5	UC-31062-16	46.95	UC-31062-16X	54.20
.062	.083	.120	.303	.325	1.250	.1468	.3125	2.5	UC-31062-20	46.95	UC-31062-20X	54.20
.062	.095	.130	.365	.387	1.000	.1775	.3750	2.5	UC-37062-16	61.95	UC-37062-16X	70.55
.062	.125	.180	.490	.512	1.000	.2400	.5000	3.0	UC-50062-16	86.75	UC-50062-16X	98.45
.062	.125	.180	.490	.512	1.500	.2400	.5000	3.0	UC-50062-24	86.75		
.093	.095	.130	.365	.387	1.000	.1775	.3750	2.5	UC-37093-16	61.95	UC-37093-16X	70.55
.093	.125	.180	.490	.512	1.500	.2400	.5000	3.0	UC-50093-24	86.75	UC-50093-24X	98.45
.125	.095	.130	.365	.387	1.000	.1775	.3750	2.5	UC-37125-16	61.95	UC-37125-16X	70.55
.125	.095	.130	.365	.387	1.250	.1775	.3750	2.5	UC-37125-20	61.95		
.125	.125	.180	.490	.512	1.000	.2400	.5000	3.0	UC-50125-16	86.75	UC-50125-16X	98.45
.125	.125	.180	.490	.512	1.500	.2400	.5000	3.0	UC-50125-24	86.75	UC-50125-24X	98.45

*Suggested Minimum Bore Diameter to accommodate chip evacuation and retract clearance in static (not live) applications.

Standard – Grooving Tools

See pgs 33-37 for standard tool holders

UP

Standard – Grooving Tools

Undercutting – Full Radius

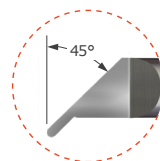
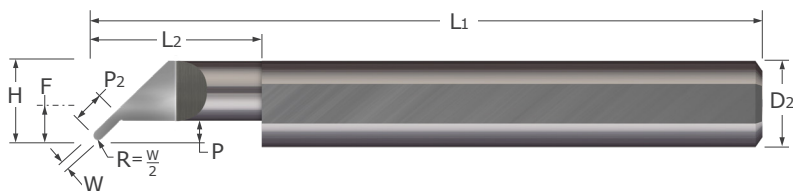

- Designed for plunging full radius undercut grooves and profiling
- Polished split face for improved edge retention and chip evacuation while reducing galling
- Full radius profile
- Lockdown flat automatically locates tool on center
- AlTiN coated option provides added lubricity and increased wear resistance in difficult to machine materials
- Solid carbide ■ CNC ground in the USA

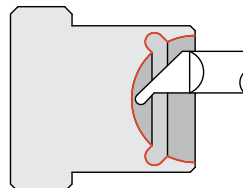

Width	Projection	Angled Projection	Head Width	Minimum Bore Diameter*	Maximum Bore Depth	Centerline Offset	Shank Diameter	Overall Length	Uncoated		AlTiN Coated	
									Tool #	Price	Tool #	Price
W $\begin{matrix} +.002'' \\ -.000'' \end{matrix}$	P	P ₂	H		L ₂ $\begin{matrix} +.050'' \\ -.000'' \end{matrix}$	F	D ₂ (h6)	L ₁	Tool #	Price	Tool #	Price
.020	.050	.077	.180	.198	.375	.0862	.1875	2.0	UP-18020-6	40.25	UP-18020-6X	45.00
.020	.050	.077	.180	.198	.500	.0862	.1875	2.0	UP-18020-8	40.25	UP-18020-8X	45.00
.025	.050	.078	.180	.198	.375	.0862	.1875	2.0	UP-18025-6	40.25	UP-18025-6X	45.00
.025	.050	.078	.180	.198	.500	.0862	.1875	2.0	UP-18025-8	40.25	UP-18025-8X	45.00
.025	.060	.092	.240	.262	.375	.1150	.2500	2.5	UP-25025-6	43.30	UP-25025-6X	49.35
.025	.060	.092	.240	.262	.500	.1150	.2500	2.5	UP-25025-8	43.30	UP-25025-8X	49.35
.030	.050	.079	.180	.198	.375	.0862	.1875	2.0	UP-18030-6	40.25	UP-18030-6X	45.00
.030	.050	.079	.180	.198	.500	.0862	.1875	2.0	UP-18030-8	40.25	UP-18030-8X	45.00
.030	.060	.094	.240	.262	.500	.1150	.2500	2.5	UP-25030-8	43.30	UP-25030-8X	49.35
.030	.060	.094	.240	.262	1.000	.1150	.2500	2.5	UP-25030-16	43.30	UP-25030-16X	49.35
.050	.083	.132	.303	.325	.500	.1468	.3125	2.5	UP-31050-8	53.90	UP-31050-8X	61.15
.050	.083	.132	.303	.325	1.000	.1468	.3125	2.5	UP-31050-16	53.90	UP-31050-16X	61.15
.062	.083	.136	.303	.325	1.000	.1468	.3125	2.5	UP-31062-16	53.90	UP-31062-16X	61.15
.062	.083	.136	.303	.325	1.250	.1468	.3125	2.5	UP-31062-20	53.90	UP-31062-20X	61.15
.062	.095	.153	.365	.387	1.000	.1775	.3750	2.5	UP-37062-16	68.95	UP-37062-16X	77.55
.062	.095	.153	.365	.387	1.250	.1775	.3750	2.5	UP-37062-20	68.95	UP-37062-20X	77.55
.062	.125	.195	.490	.512	1.000	.2400	.5000	3.0	UP-50062-16	95.10	UP-50062-16X	106.80
.062	.125	.195	.490	.512	1.500	.2400	.5000	3.0	UP-50062-24	95.10	UP-50062-24X	106.80
.093	.095	.162	.365	.387	1.000	.1775	.3750	2.5	UP-37093-16	68.95	UP-37093-16X	77.55
.093	.125	.204	.490	.512	1.000	.2400	.5000	3.0	UP-50093-16	95.10	UP-50093-16X	106.80
.093	.125	.204	.490	.512	1.500	.2400	.5000	3.0	UP-50093-24	95.10	UP-50093-24X	106.80
.125	.095	.171	.365	.387	1.000	.1775	.3750	2.5	UP-37125-16	68.95	UP-37125-16X	77.55
.125	.095	.171	.365	.387	1.250	.1775	.3750	2.5	UP-37125-20	68.95	UP-37125-20X	77.55
.125	.125	.213	.490	.512	1.000	.2400	.5000	3.0	UP-50125-16	95.10	UP-50125-16X	106.80
.125	.125	.213	.490	.512	1.500	.2400	.5000	3.0	UP-50125-24	95.10	UP-50125-24X	106.80

*Suggested Minimum Bore Diameter to accommodate chip evacuation and retract clearance in static (not live) applications.

Standard - Grooving Tools

OR

O-Ring Grooving

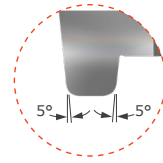
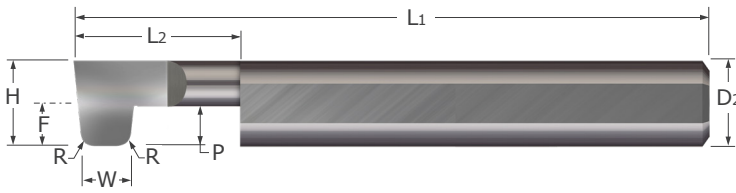

- Designed for creating O-ring grooves
- Polished split face for improved edge retention and chip evacuation while reducing galling
- Lockdown flat automatically locates tool on center
- AlTiN coated option provides added lubricity and increased wear resistance in difficult to machine materials
- Solid carbide ■ CNC ground in the USA

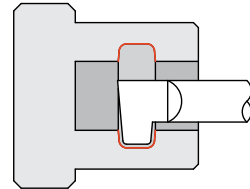

Width	Head Width	Minimum Bore Diameter*	Maximum Bore Depth	Radius	Projection	Centerline Offset	Shank Diameter	Overall Length	Uncoated		AlTiN Coated	
									Tool #	Price	Tool #	Price
W $\begin{matrix} +.002'' \\ -.000'' \end{matrix}$	H		L2 $\begin{matrix} +.050'' \\ -.000'' \end{matrix}$	R $\begin{matrix} +.010'' \\ -.000'' \end{matrix}$	P	F	D2 (h6)	L1				
.096	.250	.272	.500	.010	.100	.1250	.2500	2.5	OR-096-8	36.35	OR-096-8X	42.40
.141	.250	.272	.562	.35	.100	.1250	.2500	2.5	OR-141-9	36.35	OR-141-9X	42.40
.144	.250	.272	.625	.035	.100	.1250	.2500	2.5	OR-144-10	36.35		
.174	.375	.397	.750	.010	.115	.1875	.3750	2.5	OR-174-12	59.65	OR-174-12X	68.25
.208	.375	.397	.812	.035	.115	.1875	.3750	2.5	OR-208-13	59.65	OR-208-13X	68.25
.241	.375	.397	.938	.035	.115	.1875	.3750	2.5	OR-241-15	59.65		

*Suggested Minimum Bore Diameter to accommodate chip evacuation and retract clearance in static (not live) applications.

Standard - Grooving Tools

See pgs 33-37 for standard tool holders

FG

Standard - Grooving Tools

Face Grooving - Square

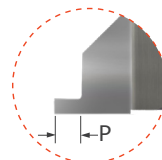
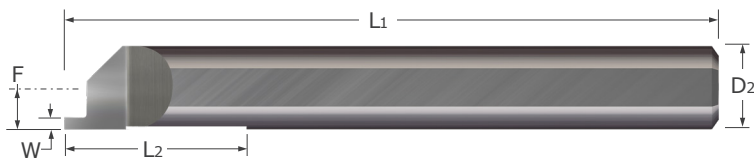

- Designed for generating square grooves in the face of the part
- Polished split face for improved edge retention and chip evacuation while reducing galling
- Split face geometry provides optimal edge strength
- Relief ground along Maximum Bore Depth (L2) to avoid interference during deep hole applications
- Sharp corner profile
- Lockdown flat automatically locates tool on center
- AlTiN coated option provides added lubricity and increased wear resistance in difficult to machine materials ■ Solid carbide ■ CNC ground in the USA

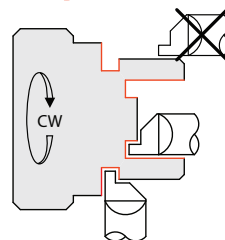

Width	Projection	Minimum Groove Diameter*	Maximum Bore Depth	Centerline Offset	Shank Diameter	Overall Length	Uncoated		AlTiN Coated	
W $^{+.002}$ / $-.000}$ "	P $^{+.015}$ / $-.000}$ "		L2	F	D2 (h6)	L1	Tool #	Price	Tool #	Price
.015	.025	.197	.750	.0937	.1875	2.0	FG-187-015-025	26.15	FG-187-015-025X	30.50
.015	.025	.260	1.000	.1250	.2500	2.5	FG-250-015-025	29.15	FG-250-015-025X	35.20
.017	.025	.197	.750	.0937	.1875	2.0	FG-187-017-025	26.15	FG-187-017-025X	30.50
.017	.025	.260	1.000	.1250	.2500	2.5	FG-250-017-025	29.15	FG-250-017-025X	35.20
.020	.025	.135	.375	.0625	.1250	1.5	FG-125-020-025	25.30	FG-125-020-025X	29.10
.020	.025	.197	.750	.0937	.1875	2.0	FG-187-020-025	26.15	FG-187-020-025X	30.50
.020	.025	.260	1.000	.1250	.2500	2.5	FG-250-020-025	29.15	FG-250-020-025X	35.20
.020	.050	.190	.155	.0862	.1875	2.0	FG-180-020	26.15	FG-180-020X	30.50
.020	.050	.197	.750	.0937	.1875	2.0	FG-187-020-050	26.15	FG-187-020-050X	30.50
.020	.050	.240	.215	.1200	.2500	2.5	FG-230-020	29.15	FG-230-020X	33.55
.020	.050	.260	.215	.1250	.2500	2.5	FG-250-020	29.15	FG-250-020X	35.20
.025	.025	.135	.375	.0625	.1250	1.5	FG-125-025-025	25.30	FG-125-025-025X	29.10
.025	.025	.197	.750	.0937	.1875	2.0	FG-187-025-025	26.15	FG-187-025-025X	30.50
.025	.025	.260	1.000	.1250	.2500	2.5	FG-250-025-025	29.15	FG-250-025-025X	35.20
.025	.050	.197	.750	.0937	.1875	2.0	FG-187-025-050	26.15	FG-187-025-050X	30.50
.025	.050	.260	1.000	.1250	.2500	2.5	FG-250-025-050	29.15	FG-250-025-050X	35.20
.030	.050	.135	.375	.0625	.1250	1.5	FG-125-030-050	25.30	FG-125-030-050X	29.10
.030	.050	.190	.155	.0862	.1875	2.0	FG-180-030	26.15	FG-180-030X	30.90
.030	.050	.197	.750	.0937	.1875	2.0	FG-187-030-050	26.15	FG-187-030-050X	30.50
.030	.050	.260	.215	.1250	.2500	2.5	FG-250-030	29.15	FG-250-030X	35.20
.030	.050	.322	.240	.1563	.3125	2.5	FG-312-030	39.85	FG-312-030X	47.10
.030	.050	.385	.275	.1875	.3750	2.5	FG-375-030	55.50	FG-375-030X	64.10
.030	.075	.197	.750	.0937	.1875	2.0	FG-187-030-075	26.15	FG-187-030-075X	30.50
.030	.075	.260	1.000	.1250	.2500	2.5	FG-250-030-075	29.15	FG-250-030-075X	35.20
.039	.050	.197	.750	.0937	.1875	2.0	FG-187-039-050	26.15	FG-187-039-050X	30.50
.039	.050	.260	1.000	.1250	.2500	2.5	FG-250-039-050	29.15	FG-250-039-050X	35.20
.039	.050	.385	1.250	.1875	.3750	2.5	FG-375-039-050	55.50	FG-375-039-050X	64.10
.039	.075	.197	.750	.0937	.1875	2.0	FG-187-039-075	26.15	FG-187-039-075X	30.50
.039	.075	.260	1.000	.1250	.2500	2.5	FG-250-039-075	29.15	FG-250-039-075X	35.20
.040	.050	.197	.750	.0937	.1875	2.0	FG-187-040-050	26.15	FG-187-040-050X	30.50
.040	.050	.260	.215	.1250	.2500	2.5	FG-250-040	29.15	FG-250-040X	35.20
.040	.050	.322	.240	.1563	.3125	2.5	FG-312-040	39.85	FG-312-040X	47.10
.040	.050	.385	1.250	.1875	.3750	2.5	FG-375-040-050	55.50	FG-375-040-050X	64.10
.040	.075	.197	.750	.0937	.1875	2.0	FG-187-040-075	26.15	FG-187-040-075X	30.50
.040	.075	.260	1.000	.1250	.2500	2.5	FG-250-040-075	29.15	FG-250-040-075X	35.20

*Minimum Groove Diameter provides proper clearance on outside of tooth during initial plunge.

Continued on next page

See pgs 33-37 for standard tool holders

Standard - Grooving Tools



Standard – Grooving Tools

Face Grooving – Square (cont.)

FG

Continued from previous page

Width	Projection	Minimum Groove Diameter*	Maximum Bore Depth	Centerline Offset	Shank Diameter	Overall Length	Uncoated		AlTiN Coated	
							Tool #	Price	Tool #	Price
W $^{+.002}$ / $_{-.000}$ "	P $^{+.015}$ / $_{-.000}$ "		L ₂	F	D ₂ (h6)	L ₁				
.050	.050	.197	.750	.0937	.1875	2.0	FG-187-050-050	26.15	FG-187-050-050X	30.50
.050	.050	.260	.215	.1250	.2500	2.5	FG-250-050	29.15	FG-250-050X	35.20
.050	.050	.322	.240	.1563	.3125	2.5	FG-312-050	39.85	FG-312-050X	47.10
.050	.050	.385	1.250	.1875	.3750	2.5	FG-375-050-050	55.50	FG-375-050-050X	64.10
.050	.075	.197	.750	.0937	.1875	2.0	FG-187-050-075	26.15	FG-187-050-075X	30.50
.050	.075	.260	1.000	.1250	.2500	2.5	FG-250-050-075	29.15	FG-250-050-075X	35.20
.050	.075	.322	1.125	.1563	.3125	2.5	FG-312-050-075	39.85	FG-312-050-075X	47.10
.059	.075	.197	.750	.0937	.1875	2.0	FG-187-059-075	26.15	FG-187-059-075X	30.50
.059	.075	.260	1.000	.1250	.2500	2.5	FG-250-059-075	29.15	FG-250-059-075X	35.20
.059	.075	.385	1.250	.1875	.3750	2.5	FG-375-059-075	55.50	FG-375-059-075X	64.10
.059	.100	.197	.750	.0937	.1875	2.0	FG-187-059-100	26.15	FG-187-059-100X	30.50
.059	.100	.260	1.000	.1250	.2500	2.5	FG-250-059-100	29.15	FG-250-059-100X	35.20
.062	.075	.197	.750	.0937	.1875	2.0	FG-187-062-075	26.15	FG-187-062-075X	30.50
.062	.075	.260	1.000	.1250	.2500	2.5	FG-250-062-075	29.15	FG-250-062-075X	35.20
.062	.075	.322	.250	.1563	.3125	2.5	FG-312-062	39.85	FG-312-062X	47.10
.062	.075	.385	.285	.1875	.3750	2.5	FG-375-062	55.50	FG-375-062X	64.10
.062	.075	.510	.350	.2500	.5000	3.0	FG-500-062	62.75	FG-500-062X	74.45
.062	.075	.635	.410	.3125	.6250	3.5	FG-625-062	102.30	FG-625-062X	116.85
.062	.100	.197	.750	.0937	.1875	2.0	FG-187-062-100	26.15	FG-187-062-100X	30.50
.062	.100	.260	1.000	.1250	.2500	2.5	FG-250-062-100	29.15	FG-250-062-100X	35.20
.062	.100	.322	1.125	.1563	.3125	2.5	FG-312-062-100	39.85	FG-312-062-100X	47.10
.062	.100	.385	1.250	.1875	.3750	2.5	FG-375-062-100	55.50	FG-375-062-100X	64.10
.062	.150	.197	.750	.0937	.1875	2.0	FG-187-062-150	26.15	FG-187-062-150X	30.50
.062	.150	.260	1.000	.1250	.2500	2.5	FG-250-062-150	29.15	FG-250-062-150X	35.20
.062	.150	.322	1.125	.1563	.3125	2.5	FG-312-062-150	39.85	FG-312-062-150X	47.10
.062	.150	.385	1.250	.1875	.3750	2.5	FG-375-062-150	55.50	FG-375-062-150X	64.10
.078	.100	.260	1.000	.1250	.2500	2.5	FG-250-078-100	29.15	FG-250-078-100X	35.20
.078	.100	.322	1.125	.1563	.3125	2.5	FG-312-078-100	39.85	FG-312-078-100X	47.10
.078	.100	.385	.300	.1875	.3750	2.5	FG-375-078	55.50	FG-375-078X	64.10
.093	.100	.385	.320	.1875	.3750	2.5	FG-375-093	55.50	FG-375-093X	64.10
.093	.100	.510	.375	.2500	.5000	3.0	FG-500-093	62.75	FG-500-093X	74.45
.093	.100	.635	.430	.3125	.6250	3.5	FG-625-093	102.30	FG-625-093X	116.85
.093	.100	.760	.475	.3750	.7500	4.0	FG-750-093	162.75	FG-750-093X	180.05
.093	.150	.322	1.125	.1563	.3125	2.5	FG-312-093-150	39.85	FG-312-093-150X	47.10
.093	.150	.385	1.250	.1875	.3750	2.5	FG-375-093-150	55.50	FG-375-093-150X	64.10
.118	.150	.385	1.250	.1875	.3750	2.5	FG-375-118-150	55.50	FG-375-118-150X	64.10
.125	.100	.385	.320	.1875	.3750	2.5	FG-375-125	55.50	FG-375-125X	64.10
.125	.100	.510	.350	.2500	.5000	3.0	FG-500-125	62.75	FG-500-125X	74.45
.125	.100	.760	.475	.3750	.7500	4.0	FG-750-125	162.75	FG-750-125X	180.05
.125	.200	.385	1.250	.1875	.3750	2.5	FG-375-125-200	55.50	FG-375-125-200X	64.10
.156	.100	.510	.375	.2500	.5000	3.0	FG-500-156	62.75	FG-500-156X	74.45
.156	.100	.635	.430	.3125	.6250	3.5	FG-625-156	102.30	FG-625-156X	116.85
.156	.100	.760	.475	.3750	.7500	4.0	FG-750-156	162.75		
.187	.150	.635	.480	.3125	.6250	3.5	FG-625-187	102.30	FG-625-187X	116.85
.187	.150	.760	.525	.3750	.7500	4.0	FG-750-187	162.75	FG-750-187X	180.05
.250	.250	.760	.625	.3750	.7500	4.0	FG-750-250	162.75	FG-750-250X	180.05

*Minimum Groove Diameter provides proper clearance on outside of tooth during initial plunge.

See pgs 33-37 for standard tool holders

FGC

Standard – Grooving Tools

Face Grooving – Corner Radius

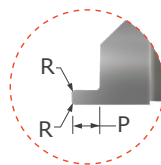
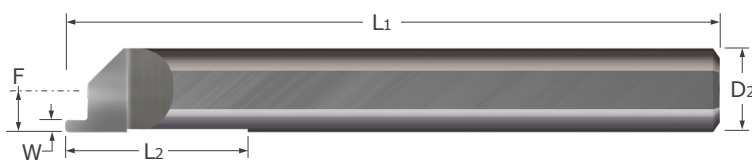

- Designed for generating corner radius grooves in the face of the part
- Polished split face for improved edge retention and chip evacuation while reducing galling
- Split face geometry provides optimal edge strength
- Relief ground along Maximum Bore Depth (L₂) to avoid interference during deep hole applications
- Corner radius profile
- Lockdown flat automatically locates tool on center
- AlTiN coated option provides added lubricity and increased wear resistance in difficult to machine materials
- Solid carbide ■ CNC ground in the USA

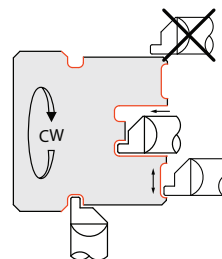

Width	Projection	Minimum Groove Diameter*	Radius	Maximum Bore Depth	Centerline Offset	Shank Diameter	Overall Length	Uncoated		AlTiN Coated	
								Tool #	Price	Tool #	Price
W $^{+.002"}_{-.000"}$	P $^{+.015"}_{-.000"}$		R $^{+.001"}_{-.001"}$	L ₂	F	D ₂ (h6)	L ₁				
.015	.025	.197	.003	.750	.0938	.1875	2.0	FGC3-187-015-025	28.05	FGC3-187-015-025X	32.40
.015	.025	.260	.003	1.000	.1250	.2500	2.5	FGC3-250-015-025	31.05	FGC3-250-015-025X	37.10
.017	.025	.197	.003	.750	.0938	.1875	2.0	FGC3-187-017-025	28.05	FGC3-187-017-025X	32.40
.017	.025	.260	.003	1.000	.1250	.2500	2.5	FGC3-250-017-025	31.05	FGC3-250-017-025X	37.10
.020	.025	.135	.003	.375	.0625	.1250	1.5	FGC3-125-020-025	27.15	FGC3-125-020-025X	31.00
.020	.025	.197	.003	.750	.0938	.1875	2.0	FGC3-187-020-025	28.05	FGC3-187-020-025X	32.40
.020	.025	.260	.003	1.000	.1250	.2500	2.5	FGC3-250-020-025	31.05	FGC3-250-020-025X	37.10
.025	.025	.135	.003	.375	.0625	.1250	1.5	FGC3-125-025-025	27.15	FGC3-125-025-025X	31.00
.025	.025	.197	.003	.750	.0938	.1875	2.0	FGC3-187-025-025	28.05	FGC3-187-025-025X	32.40
.025	.025	.260	.003	1.000	.1250	.2500	2.5	FGC3-250-025-025	31.05	FGC3-250-025-025X	37.10
.030	.050	.135	.003	.375	.0625	.1250	1.5	FGC3-125-030-050	27.15	FGC3-125-030-050X	31.00
.030	.050	.197	.003	.750	.0938	.1875	2.0	FGC3-187-030-050	28.05	FGC3-187-030-050X	32.40
.030	.050	.260	.003	1.000	.1250	.2500	2.5	FGC3-250-030-050	31.05	FGC3-250-030-050X	37.10
.030	.050	.322	.003	1.125	.1563	.3125	2.5	FGC3-312-030-050	41.75	FGC3-312-030-050X	49.00
.030	.050	.385	.003	1.250	.1875	.3750	2.5	FGC3-375-030-050	57.30	FGC3-375-030-050X	65.90
.039	.050	.197	.003	.750	.0938	.1875	2.0	FGC3-187-039-050	28.05	FGC3-187-039-050X	32.40
.039	.050	.260	.003	1.000	.1250	.2500	2.5	FGC3-250-039-050	31.05	FGC3-250-039-050X	37.10
.039	.050	.385	.003	1.250	.1875	.3750	2.5	FGC3-375-039-050	57.30	FGC3-375-039-050X	65.90
.040	.050	.197	.003	.750	.0938	.1875	2.0	FGC3-187-040-050	28.05	FGC3-187-040-050X	32.40
.040	.050	.260	.003	1.000	.1250	.2500	2.5	FGC3-250-040-050	31.05	FGC3-250-040-050X	37.10
.040	.050	.322	.003	1.125	.1563	.3125	2.5	FGC3-312-040-050	41.75	FGC3-312-040-050X	49.00
.040	.050	.385	.003	1.250	.1875	.3750	2.5	FGC3-375-040-050	57.30	FGC3-375-040-050X	65.90
.050	.050	.197	.003	.750	.0938	.1875	2.0	FGC3-187-050-050	28.05	FGC3-187-050-050X	32.40
.050	.050	.260	.003	1.000	.1250	.2500	2.5	FGC3-250-050-050	31.05	FGC3-250-050-050X	37.10
.050	.050	.322	.003	1.125	.1563	.3125	2.5	FGC3-312-050-050	41.75	FGC3-312-050-050X	49.00
.050	.050	.385	.003	1.250	.1875	.3750	2.5	FGC3-375-050-050	57.30	FGC3-375-050-050X	65.90
.059	.075	.385	.003	1.250	.1875	.3750	2.5	FGC3-375-059-075	57.30	FGC3-375-059-075X	65.90

*Minimum Groove Diameter provides proper clearance on outside of tooth during initial plunge.

Continued on next page

Standard – Grooving Tools

Face Grooving – Corner Radius (cont.)

Continued from previous page

Width	Projection	Minimum Groove Diameter*	Radius	Maximum Bore Depth	Centerline Offset	Shank Diameter	Overall Length	Uncoated		AlTiN Coated	
								Tool #	Price	Tool #	Price
W $^{+.002"}_{-.000"}$	P $^{+.015"}_{-.000"}$		R $^{+.001"}_{-.001"}$	L ₂	F	D ₂ (h6)	L ₁				
.062	.075	.197	.003	.750	.0938	.1875	2.0	FGC3-187-062-075	28.05	FGC3-187-062-075X	32.40
.062	.075	.260	.003	1.000	.1250	.2500	2.5	FGC3-250-062-075	31.05	FGC3-250-062-075X	37.10
.062	.075	.322	.003	1.125	.1563	.3125	2.5	FGC3-312-062-075	41.75	FGC3-312-062-075X	49.00
.062	.075	.385	.003	1.250	.1875	.3750	2.5	FGC3-375-062-075	57.30	FGC3-375-062-075X	65.90
.062	.100	.197	.003	.750	.0938	.1875	2.0	FGC3-187-062-100	28.05	FGC3-187-062-100X	32.40
.062	.100	.260	.003	1.000	.1250	.2500	2.5	FGC3-250-062-100	31.05	FGC3-250-062-100X	37.10
.078	.100	.260	.003	1.000	.1250	.2500	2.5	FGC3-250-078-100	31.05	FGC3-250-078-100X	37.10
.078	.100	.322	.003	1.125	.1563	.3125	2.5	FGC3-312-078-100	41.75	FGC3-312-078-100X	49.00
.078	.100	.385	.003	1.250	.1875	.3750	2.5	FGC3-375-078-100	57.30	FGC3-375-078-100X	65.90
.093	.100	.385	.006	1.250	.1875	.3750	2.5	FGC6-375-093-100	57.30	FGC6-375-093-100X	65.90
.093	.150	.322	.006	1.125	.1563	.3125	2.5	FGC6-312-093-150	41.75	FGC6-312-093-150X	49.00
.118	.150	.385	.006	1.250	.1875	.3750	2.5	FGC6-375-118-150	57.30	FGC6-375-118-150X	65.90
.125	.100	.385	.006	1.250	.1875	.3750	2.5	FGC6-375-125-100	57.30	FGC6-375-125-100X	65.90

*Minimum Groove Diameter provides proper clearance on outside of tooth during initial plunge.

Standard – Grooving Tools



Check Real-Time Availability of Up to 50 Tools at Once

On Micro100.com/check-stock

See pgs 33-37 for standard tool holders

FGF

Standard – Grooving Tools

Face Grooving – Full Radius

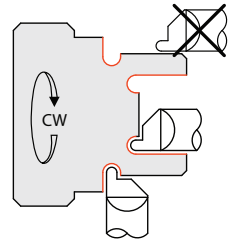
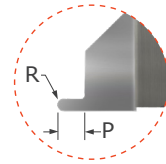
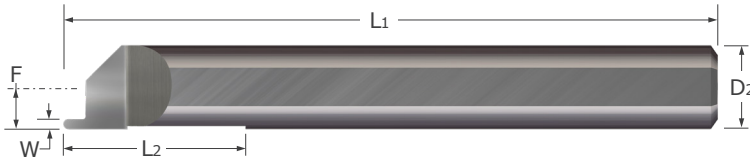

- Designed for generating full radius grooves in the face of the part
- Polished split face for improved edge retention and chip evacuation while reducing galling
- Split face geometry provides optimal edge strength
- Relief ground along Maximum Bore Depth (L2) to avoid interference during deep hole applications
- Full radius profile
- Lockdown flat automatically locates tool on center
- AlTiN coated option provides added lubricity and increased wear resistance in difficult to machine materials
- Solid carbide ■ CNC ground in the USA

Width	Radius	Projection	Minimum Groove Diameter*	Maximum Bore Depth	Centerline Offset	Shank Diameter	Overall Length	Uncoated		AlTiN Coated	
								Tool #	Price	Tool #	Price
W $^{+.002"}_{-.000"}$	R	P $^{+.030"}_{-.000"}$		L2	F	D2 (h6)	L1				
.015	.0075	.025	.197	.750	.0937	.1875	2.0	FGF-187-015-025	26.75	FGF-187-015-025X	31.00
.015	.0075	.025	.260	1.000	.1250	.2500	2.5	FGF-250-015-025	30.05	FGF-250-015-025X	36.10
.017	.0085	.025	.197	.750	.0937	.1875	2.0	FGF-187-017-025	26.75	FGF-187-017-025X	31.00
.017	.0085	.025	.260	1.000	.1250	.2500	2.5	FGF-250-017-025	30.05	FGF-250-017-025X	36.10
.020	.0100	.050	.135	.375	.0625	.1250	1.5	FGF-125-020-050	25.85	FGF-125-020-050X	29.70
.020	.0100	.050	.190	.180	.0860	.1875	2.0	FGF-180-020	26.75	FGF-180-020X	31.00
.020	.0100	.050	.197	.750	.0937	.1875	2.0	FGF-187-020-050	26.75	FGF-187-020-050X	31.00
.020	.0100	.050	.240	.230	.1050	.2500	2.5	FGF-230-020	30.05	FGF-230-020X	36.10
.020	.0100	.050	.260	.230	.1250	.2500	2.5	FGF-250-020	30.05	FGF-250-020X	36.10
.025	.0125	.050	.135	.375	.0625	.1250	1.5	FGF-125-025-050	25.85	FGF-125-025-050X	29.70
.025	.0125	.050	.197	.750	.0937	.1875	2.0	FGF-187-025-050	26.75	FGF-187-025-050X	31.00
.025	.0125	.050	.260	1.000	.1250	.2500	2.5	FGF-250-025-050	30.05	FGF-250-025-050X	36.10
.030	.0150	.050	.135	.375	.0625	.1250	1.5	FGF-125-030-050	25.85	FGF-125-030-050X	29.70
.030	.0150	.050	.190	.180	.0860	.1875	2.0	FGF-180-030	26.75	FGF-180-030X	31.00
.030	.0150	.050	.197	.750	.0937	.1875	2.0	FGF-187-030-050	26.75	FGF-187-030-050X	31.00
.030	.0150	.050	.260	.230	.1250	.2500	2.5	FGF-250-030	30.05	FGF-250-030X	36.10
.039	.0195	.075	.197	.750	.0937	.1875	2.0	FGF-187-039-075	26.75	FGF-187-039-075X	31.00
.039	.0195	.075	.260	1.000	.1250	.2500	2.5	FGF-250-039-075	30.05	FGF-250-039-075X	36.10
.040	.0200	.050	.260	.230	.1250	.2500	2.5	FGF-250-040	30.05	FGF-250-040X	36.10
.040	.0200	.075	.197	.750	.0937	.1875	2.0	FGF-187-040-075	26.75	FGF-187-040-075X	31.00
.040	.0200	.075	.260	1.000	.1250	.2500	2.5	FGF-250-040-075	30.05	FGF-250-040-075X	36.10
.050	.0250	.050	.322	.255	.1563	.3125	2.5	FGF-312-050	41.10	FGF-312-050X	48.35
.050	.0250	.075	.197	.750	.0937	.1875	2.0	FGF-187-050-075	26.75	FGF-187-050-075X	31.00
.050	.0250	.075	.260	1.000	.1250	.2500	2.5	FGF-250-050-075	30.05	FGF-250-050-075X	36.10
.050	.0250	.075	.322	1.125	.1563	.3125	2.5	FGF-312-050-075	41.10	FGF-312-050-075X	48.35
.062	.0310	.075	.322	.280	.1563	.3125	2.5	FGF-312-062	41.10	FGF-312-062X	48.35
.062	.0310	.075	.385	.315	.1875	.3750	2.5	FGF-375-062	57.10	FGF-375-062X	65.70
.062	.0310	.100	.197	.750	.0937	.1875	2.0	FGF-187-062-100	26.75	FGF-187-062-100X	31.00
.062	.0310	.100	.260	1.000	.1250	.2500	2.5	FGF-250-062-100	30.05	FGF-250-062-100X	36.10
.062	.0310	.100	.322	1.125	.1563	.3125	2.5	FGF-312-062-100	41.10	FGF-312-062-100X	48.35
.062	.0310	.100	.385	1.250	.1875	.3750	2.5	FGF-375-062-100	57.10	FGF-375-062-100X	65.70
.078	.0390	.100	.385	.335	.1875	.3750	2.5	FGF-375-078	57.10	FGF-375-078X	65.70
.093	.0465	.100	.385	.335	.1875	.3750	2.5	FGF-375-093	57.10	FGF-375-093X	65.70
.125	.0625	.100	.385	.335	.1875	.3750	2.5	FGF-375-125	57.10	FGF-375-125X	65.70

*Minimum Groove Diameter provides proper clearance on outside of tooth during initial plunge.

See pgs 33-37 for standard tool holders

Standard – Grooving Tools

Face Grooving – Internal Tooth – Square

FGI

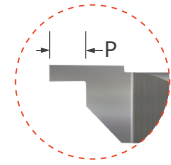
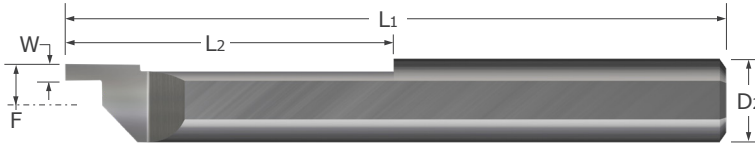

- Designed to generate square grooves around a boss in the face of a part for right hand grooving applications (M03) (See Graphic)
- Significantly reduces cycle times, as right hand design allows for multiple tools to be run simultaneously
- Relief ground along Maximum Turn Depth (L₂) to avoid interference during long turning applications
- Polished split face for improved edge retention and chip evacuation while reducing galling
- Split face geometry provides optimal edge strength
- Sharp corner profile
- Lockdown flat automatically locates tool on center
- AlTiN coated option provides added lubricity and increased wear resistance in difficult to machine materials
- Solid carbide ■ CNC ground in the USA

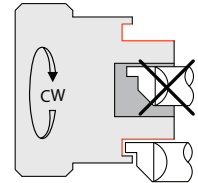

Standard – Grooving Tools

Width	Projection	Minimum Groove Diameter*	Maximum Turn Depth	Centerline Offset	Shank Diameter	Overall Length	Uncoated		AlTiN Coated	
							Tool #	Price	Tool #	Price
W $\begin{matrix} +.002" \\ -.000" \end{matrix}$	P $\begin{matrix} +.015" \\ -.000" \end{matrix}$		L ₂	F	D ₂ (h6)	L ₁				
.020	.040	.260	.750	.1150	.2500	2.5	FGI-8240	30.25	FGI-8240X	36.30
.020	.040	.260	1.250	.1150	.2500	2.5	FGI-6198	30.25	FGI-6198X	36.30
.020	.040	.322	.750	.1463	.3125	2.5	FGI-9800	41.35	FGI-9800X	48.60
.020	.040	.322	1.250	.1463	.3125	2.5	FGI-6738	41.35	FGI-6738X	48.60
.030	.060	.260	.750	.1150	.2500	2.5	FGI-6600	30.25	FGI-6600X	36.30
.030	.060	.260	1.250	.1150	.2500	2.5	FGI-3461	30.25	FGI-3461X	36.30
.030	.060	.322	.750	.1463	.3125	2.5	FGI-5774	41.35	FGI-5774X	48.60
.030	.060	.322	1.250	.1463	.3125	2.5	FGI-1413	41.35	FGI-1413X	48.60
.040	.080	.260	.750	.1150	.2500	2.5	FGI-6481	30.25	FGI-6481X	36.30
.040	.080	.260	1.250	.1150	.2500	2.5	FGI-9741	30.25	FGI-9741X	36.30
.040	.080	.322	.750	.1463	.3125	2.5	FGI-8157	41.35	FGI-8157X	48.60
.040	.080	.322	1.250	.1463	.3125	2.5	FGI-9114	41.35	FGI-9114X	48.60
.050	.100	.260	.750	.1150	.2500	2.5	FGI-1311	30.25	FGI-1311X	36.30
.050	.100	.260	1.250	.1150	.2500	2.5	FGI-7516	30.25	FGI-7516X	36.30
.050	.100	.322	.750	.1463	.3125	2.5	FGI-5336	41.35	FGI-5336X	48.60
.050	.100	.322	1.250	.1463	.3125	2.5	FGI-9489	41.35	FGI-9489X	48.60
.062	.125	.322	.750	.1463	.3125	2.5	FGI-2609	41.35	FGI-2609X	48.60
.062	.125	.322	1.250	.1463	.3125	2.5	FGI-0720	41.35	FGI-0720X	48.60
.062	.125	.385	.750	.1775	.3750	2.5	FGI-3852	57.60	FGI-3852X	66.20
.062	.125	.385	1.250	.1775	.3750	2.5	FGI-8466	57.60	FGI-8466X	66.20
.078	.156	.322	.750	.1463	.3125	2.5	FGI-4397	41.35	FGI-4397X	48.60
.078	.156	.322	1.250	.1463	.3125	2.5	FGI-3465	41.35	FGI-3465X	48.60
.078	.156	.385	.750	.1775	.3750	2.5	FGI-2855	57.60	FGI-2855X	66.20
.078	.156	.385	1.250	.1775	.3750	2.5	FGI-2684	57.60	FGI-2684X	66.20
.093	.187	.322	.750	.1463	.3125	2.5	FGI-5482	41.35	FGI-5482X	48.60
.093	.187	.322	1.250	.1463	.3125	2.5	FGI-2378	41.35	FGI-2378X	48.60
.093	.187	.385	.750	.1775	.3750	2.5	FGI-1641	57.60	FGI-1641X	66.20
.093	.187	.385	1.250	.1775	.3750	2.5	FGI-1707	57.60	FGI-1707X	66.20

*Minimum Groove Diameter provides proper clearance on outside of tooth during initial plunge.

Continued on next page

See pgs 33-37 for standard tool holders



FGI

Standard – Grooving Tools
Face Grooving – Internal Tooth – Square (cont.)

Continued from previous page

	Width	Projection	Minimum Groove Diameter*	Maximum Turn Depth	Centerline Offset	Shank Diameter	Overall Length	Uncoated		AlTiN Coated	
	W ^{+0.002"} _{-.000"}	P ^{+0.015"} _{-.000"}		L ₂	F	D ₂ (h6)	L ₁	Tool #	Price	Tool #	Price
NEW	.118	.236	.385	.750	.1775	.3750	2.5	FGI-4674	57.60	FGI-4674X	66.20
NEW	.118	.236	.385	1.250	.1775	.3750	2.5	FGI-2969	57.60	FGI-2969X	66.20
NEW	.118	.236	.510	1.000	.2400	.5000	3.0	FGI-6754	65.15	FGI-6754X	76.85
NEW	.118	.236	.510	1.500	.2400	.5000	3.0	FGI-3667	65.15	FGI-3667X	76.85
NEW	.125	.250	.385	.750	.1775	.3750	2.5	FGI-1535	57.60	FGI-1535X	66.20
NEW	.125	.250	.385	1.250	.1775	.3750	2.5	FGI-7015	57.60	FGI-7015X	66.20
NEW	.125	.250	.510	1.000	.2400	.5000	3.0	FGI-4349	65.15	FGI-4349X	76.85
NEW	.125	.250	.510	1.500	.2400	.5000	3.0	FGI-4098	65.15	FGI-4098X	76.85

*Minimum Groove Diameter provides proper clearance on outside of tooth during initial plunge.

Sent Directly to Your Inbox

Valuable information about Micro 100 products and technical resources directly to your inbox. Be the first to know of newly-released tools to gain an immediate leg-up on the competition!

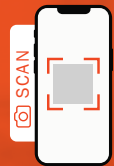

Standard – Grooving Tools

FGIC

Face Grooving – Internal Tooth – Corner Radius

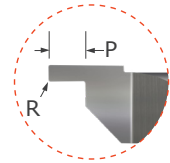
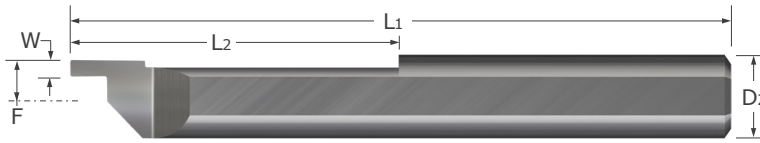

- Designed to generate corner radius grooves around a boss in the face of a part for right hand grooving applications (M03) (See Graphic)
- Significantly reduces cycle times, as right hand design allows for multiple tools to be run simultaneously
- Relief ground along Maximum Turn Depth (L2) to avoid interference during long turning applications
- Polished split face for improved edge retention and chip evacuation while reducing galling
- Split face geometry provides optimal edge strength
- Corner radius profile
- Lockdown flat automatically locates tool on center
- AlTiN coated option provides added lubricity and increased wear resistance in difficult to machine materials
- Solid carbide ■ CNC ground in the USA

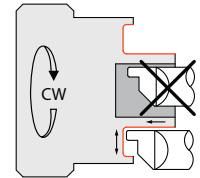

Standard – Grooving Tools

Width	Radius	Projection	Minimum Groove Diameter*	Maximum Turn Depth	Centerline Offset	Shank Diameter	Overall Length	Uncoated		AlTiN Coated	
								Tool #	Price	Tool #	Price
W $+0.002''$ $-0.000''$	R $+0.0010''$ $-0.0010''$	P $+0.015''$ $-0.000''$		L2	F	D2 (h6)	L1				
.020	.003	.040	.260	1.250	.1150	.2500	2.5	FGIC3-6198	30.80	FGIC3-6198X	36.85
.020	.003	.040	.322	1.250	.1463	.3125	2.5	FGIC3-6738	42.00	FGIC3-6738X	49.25
.030	.003	.060	.260	1.250	.1150	.2500	2.5	FGIC3-3461	30.80	FGIC3-3461X	36.85
.030	.003	.060	.322	1.250	.1463	.3125	2.5	FGIC3-1413	42.00	FGIC3-1413X	49.25
.040	.003	.080	.260	1.250	.1150	.2500	2.5	FGIC3-9741	30.80	FGIC3-9741X	36.85
.040	.003	.080	.322	1.250	.1463	.3125	2.5	FGIC3-9114	42.00	FGIC3-9114X	49.25
.050	.003	.100	.260	1.250	.1150	.2500	2.5	FGIC3-7516	30.80	FGIC3-7516X	36.85
.050	.003	.100	.322	1.250	.1463	.3125	2.5	FGIC3-9489	42.00	FGIC3-9489X	49.25
.062	.003	.125	.322	1.250	.1463	.3125	2.5	FGIC3-0720	42.00	FGIC3-0720X	49.25
.062	.003	.125	.385	1.250	.1775	.3750	2.5	FGIC3-8466	58.55	FGIC3-8466X	67.15
.078	.003	.156	.322	1.250	.1463	.3125	2.5	FGIC3-3465	42.00	FGIC3-3465X	49.25
.078	.003	.156	.385	1.250	.1775	.3750	2.5	FGIC3-2684	58.55	FGIC3-2684X	67.15
.093	.006	.187	.322	1.250	.1463	.3125	2.5	FGIC6-2378	42.00	FGIC6-2378X	49.25
.093	.006	.187	.385	1.250	.1775	.3750	2.5	FGIC6-1707	58.55	FGIC6-1707X	67.15
.118	.006	.236	.385	1.250	.1775	.3750	2.5	FGIC6-2969	58.55	FGIC6-2969X	67.15
.125	.006	.250	.385	1.250	.1775	.3750	2.5	FGIC6-7015	58.55	FGIC6-7015X	67.15

*Minimum Groove Diameter provides proper clearance on outside of tooth during initial plunge.

See pgs 33-37 for standard tool holders

FGIF

Standard – Grooving Tools
Face Grooving – Internal Tooth – Full Radius

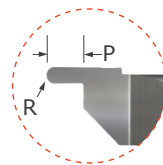
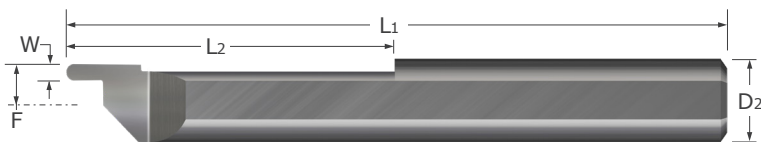

- Designed to generate full radius grooves around a boss in the face of a part for right hand grooving applications (M03) (See Graphic)
- Significantly reduces cycle times, as right hand design allows for multiple tools to be run simultaneously
- Relief ground along Maximum Turn Depth (L2) to avoid interference during long turning applications
- Polished split face for improved edge retention and chip evacuation while reducing galling
- Split face geometry provides optimal edge strength
- Full radius profile
- Lockdown flat automatically locates tool on center
- AlTiN coated option provides added lubricity and increased wear resistance in difficult to machine materials
- Solid carbide ■ CNC ground in the USA

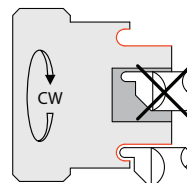

	Width	Radius	Projection	Minimum Groove Diameter*	Maximum Turn Depth	Centerline Offset	Shank Diameter	Overall Length	Uncoated		AlTiN Coated	
									Tool #	Price	Tool #	Price
	W $^{+.002''}_{-.000''}$	R $^{+.0010''}_{-.0010''}$	P $^{+.015''}_{-.000''}$		L2	F	D2 (h6)	L1				
NEW	.020	.0100	.040	.260	1.250	.1150	.2500	2.5	FGIF-6198	31.15	FGIF-6198X	37.20
NEW	.020	.0100	.040	.322	1.250	.1463	.3125	2.5	FGIF-6738	42.55	FGIF-6738X	49.80
NEW	.030	.0150	.060	.260	1.250	.1150	.2500	2.5	FGIF-3461	31.15	FGIF-3461X	37.20
NEW	.030	.0150	.060	.322	1.250	.1463	.3125	2.5	FGIF-1413	42.55	FGIF-1413X	49.80
NEW	.040	.0200	.080	.260	1.250	.1150	.2500	2.5	FGIF-9741	31.15	FGIF-9741X	37.20
NEW	.040	.0200	.080	.322	1.250	.1463	.3125	2.5	FGIF-9114	42.55	FGIF-9114X	49.80
NEW	.050	.0250	.100	.260	1.250	.1150	.2500	2.5	FGIF-7516	31.15	FGIF-7516X	37.20
NEW	.050	.0250	.100	.322	1.250	.1463	.3125	2.5	FGIF-9489	42.55	FGIF-9489X	49.80
NEW	.062	.0310	.125	.322	1.250	.1463	.3125	2.5	FGIF-0720	42.55	FGIF-0720X	49.80
NEW	.062	.0310	.125	.385	1.250	.1775	.3750	2.5	FGIF-8466	59.30	FGIF-8466X	67.90
NEW	.078	.0390	.156	.322	1.250	.1463	.3125	2.5	FGIF-3465	42.55	FGIF-3465X	49.80
NEW	.078	.0390	.156	.385	1.250	.1775	.3750	2.5	FGIF-2684	59.30	FGIF-2684X	67.90
NEW	.093	.0465	.187	.322	1.250	.1463	.3125	2.5	FGIF-2378	42.55	FGIF-2378X	49.80
NEW	.093	.0465	.187	.385	1.250	.1775	.3750	2.5	FGIF-1707	59.30	FGIF-1707X	67.90
NEW	.118	.0590	.236	.385	1.250	.1775	.3750	2.5	FGIF-2969	59.30	FGIF-2969X	67.90
NEW	.125	.0625	.250	.385	1.250	.1775	.3750	2.5	FGIF-7015	59.30	FGIF-7015X	67.90

*Minimum Groove Diameter provides proper clearance on outside of tooth during initial plunge.

Standard - Threading Tools

UN Threads - Single Point - Right Hand

IT

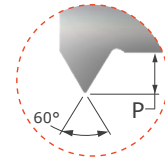
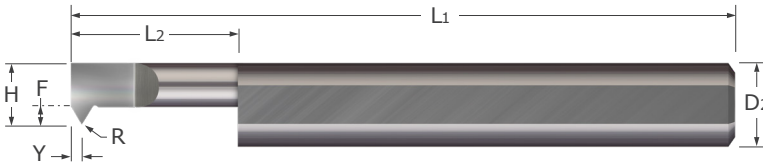

- Designed for threading multiple thread pitches (ANSI, UN, and Metric 60°)
- Polished split face for improved edge retention and chip evacuation while reducing galling
- Split face geometry provides optimal edge strength
- Corner radius profile
- Lockdown flat automatically locates tool on center
- AITiN coated option provides added lubricity and increased wear resistance in difficult to machine materials
- Solid carbide ■ CNC ground in the USA

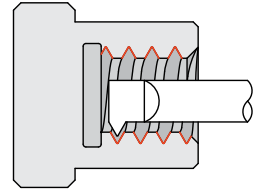

Standard - Threading Tools

Threads Per Inch	Head Width	Minimum Bore Diameter*	Maximum Bore Depth	Point Offset	Projection	Radius	Centerline Offset	Shank Dia.	Overall Length	Uncoated		AITiN Coated	
										Tool #	Price	Tool #	Price
TPI	H	L2	$^{+.050''}_{-.000''}$	$^{+.010''}_{-.000''}$	P	$^{+.001''}_{-.000''}$	F	D2 (h6)	L1	Tool #	Price	Tool #	Price
40-72	.040	.045	.075	.009	.015	.001	-.0225	.1250	1.5	IT-040075	42.40	IT-040075X	46.60
40-72	.040	.045	.100	.009	.015	.001	-.0225	.1250	1.5	IT-040100	42.40	IT-040100X	46.60
40-72	.040	.045	.150	.009	.015	.001	-.0225	.1250	1.5	IT-040150	42.40	IT-040150X	46.60
28-72	.050	.055	.100	.012	.020	.001	-.0125	.1250	1.5	IT-050100	42.40	IT-050100X	46.60
28-72	.050	.055	.150	.012	.020	.001	-.0125	.1250	1.5	IT-050150	42.40	IT-050150X	46.60
28-72	.050	.055	.200	.012	.020	.001	-.0125	.1250	1.5	IT-050200	42.40	IT-050200X	46.60
28-56	.060	.070	.150	.012	.020	.001	-.0025	.1250	1.5	IT-060150	36.95	IT-060150X	41.15
28-56	.060	.070	.200	.012	.020	.001	-.0025	.1250	1.5	IT-060200	36.95	IT-060200X	41.15
28-56	.060	.070	.250	.012	.020	.001	-.0025	.1250	1.5	IT-060250	36.95	IT-060250X	41.15
28-56	.060	.070	.300	.012	.020	.001	-.0025	.1250	1.5	IT-060300	36.95	IT-060300X	41.15

NEW

TPI	H	L2	$^{+.050''}_{-.000''}$	$^{+.010''}_{-.000''}$	P	$^{+.001''}_{-.001''}$	F	D2 (h6)	L1	Tool #	Price	Tool #	Price
28-56	.080	.090	.200	.012	.020	.002	.0175	.1250	1.5	IT-080200	33.70	IT-080200X	37.90
28-56	.080	.090	.250	.012	.020	.002	.0175	.1250	1.5	IT-080250	33.70	IT-080250X	37.80
28-56	.080	.090	.350	.012	.020	.002	.0175	.1250	1.5	IT-080350	33.70	IT-080350X	37.80
28-56	.080	.090	.500	.012	.020	.002	.0175	.1250	1.5	IT-080500	33.70	IT-080500X	37.80
24-56	.100	.110	.250	.014	.025	.002	.0375	.1250	1.5	IT-100250	33.70	IT-100250X	37.80
24-56	.100	.110	.350	.014	.025	.002	.0375	.1250	1.5	IT-100350	33.70	IT-100350X	37.80
24-56	.100	.110	.500	.014	.025	.002	.0375	.1250	1.5	IT-100500	33.70	IT-100500X	37.80
24-56	.100	.110	.600	.014	.025	.002	.0375	.1250	1.5	IT-100600	33.70	IT-100600X	37.80
20-56	.110	.126	.250	.017	.030	.002	.0475	.1250	1.5	IT-110250	33.70	IT-110250X	37.90
20-56	.110	.126	.400	.017	.030	.002	.0475	.1250	1.5	IT-110400	33.70	IT-110400X	37.90
20-56	.110	.126	.500	.017	.030	.002	.0475	.1250	1.5	IT-110500	33.70	IT-110500X	37.90
20-56	.110	.126	.600	.017	.030	.002	.0475	.1250	1.5	IT-110600	33.70	IT-110600X	37.90
20-56	.110	.126	.750	.017	.030	.002	.0475	.1250	2.0	IT-110750	34.85	IT-110750X	39.05
20-56	.120	.136	.250	.017	.030	.002	.0263	.1875	2.0	IT-120250	35.90	IT-120250X	40.50
20-56	.120	.136	.400	.017	.030	.002	.0263	.1875	2.0	IT-120400	35.90	IT-120400X	40.50
20-56	.120	.136	.500	.017	.030	.002	.0263	.1875	2.0	IT-120500	35.90	IT-120500X	40.50
20-56	.120	.136	.600	.017	.030	.002	.0263	.1875	2.0	IT-120600	35.90	IT-120600X	40.50
20-56	.120	.136	.750	.017	.030	.002	.0263	.1875	2.0	IT-120750	35.90	IT-120750X	40.50

NEW

NEW

NEW

NEW

NEW

NEW

*Suggested Minimum Bore Diameter to accommodate chip evacuation and retract clearance in static (not live) applications.

Continued on next page

See pgs 33-37 for standard tool holders
See pg 309 for tool set options

IT Standard – Threading Tools

UN Threads – Single Point – Right Hand (cont.)

Continued from previous page

Threads Per Inch	Head Width	Minimum Bore Diameter*	Maximum Bore Depth	Point Offset	Projection	Radius	Centerline Offset	Shank Dia.	Overall Length	Uncoated		AITIN Coated	
										Tool #	Price	Tool #	Price
TPI	H	L ₂	$^{+.050}_{-.000}$ "	$^{+.010}_{-.000}$ "	P	$R^{+.001}_{-.001}$ "	F	D ₂ (h6)	L ₁	Tool #	Price	Tool #	Price
NEW 16-56	.140	.156	.250	.020	.035	.002	.0463	.1875	2.0	IT-140250	35.90	IT-140250X	40.50
16-56	.140	.156	.400	.020	.035	.002	.0463	.1875	2.0	IT-140400	35.90	IT-140400X	40.50
16-56	.140	.156	.500	.020	.035	.002	.0463	.1875	2.0	IT-140500	35.90	IT-140500X	40.50
16-56	.140	.156	.750	.020	.035	.002	.0463	.1875	2.0	IT-140750	35.90	IT-140750X	40.50
NEW 16-56	.140	.156	.875	.020	.035	.002	.0463	.1875	2.0	IT-140875	35.90	IT-140875X	40.65
14-56	.160	.182	.250	.023	.040	.002	.0663	.1875	2.0	IT-160250	35.90	IT-160250X	40.50
14-56	.160	.182	.400	.023	.040	.002	.0663	.1875	2.0	IT-160400	35.90	IT-160400X	40.50
14-56	.160	.182	.500	.023	.040	.002	.0663	.1875	2.0	IT-160500	35.90	IT-160500X	40.50
14-56	.160	.182	.750	.023	.040	.002	.0663	.1875	2.0	IT-160750	35.90	IT-160750X	40.50
14-56	.160	.182	1.000	.023	.040	.002	.0663	.1875	2.0	IT-1601000	35.90	IT-1601000X	40.50
14-56	.180	.202	.350	.023	.040	.002	.0550	.2500	2.5	IT-180350	38.30	IT-180350X	44.35
14-56	.180	.202	.500	.023	.040	.002	.0550	.2500	2.5	IT-180500	38.30	IT-180500X	44.35
14-56	.180	.202	.750	.023	.040	.002	.0550	.2500	2.5	IT-180750	38.30	IT-180750X	44.35
NEW 14-56	.180	.202	1.000	.023	.040	.002	.0550	.2500	2.5	IT-1801000	38.30	IT-1801000X	44.35
NEW 14-56	.180	.202	1.125	.023	.040	.002	.0550	.2500	2.5	IT-1801125	38.30	IT-1801125X	44.35
13-56	.200	.222	.400	.026	.045	.002	.0750	.2500	2.5	IT-200400	38.30	IT-200400X	44.35
13-56	.200	.222	.600	.026	.045	.002	.0750	.2500	2.5	IT-200600	38.30	IT-200600X	44.35
13-56	.200	.222	.750	.026	.045	.002	.0750	.2500	2.5	IT-200750	38.30	IT-200750X	44.35
NEW 13-56	.200	.222	1.000	.026	.045	.002	.0750	.2500	2.5	IT-2001000	38.30	IT-2001000X	44.35
NEW 13-56	.200	.222	1.125	.026	.045	.002	.0750	.2500	2.5	IT-2001125	38.30	IT-2001125X	44.35
10-48	.230	.252	.400	.032	.055	.002	.0738	.3125	2.5	IT-230400	47.95	IT-230400X	55.20
10-48	.230	.252	.600	.032	.055	.002	.0738	.3125	2.5	IT-230600	47.95	IT-230600X	55.20
10-48	.230	.252	.750	.032	.055	.002	.0738	.3125	2.5	IT-230750	47.95	IT-230750X	55.20
NEW 10-48	.230	.252	1.000	.032	.055	.002	.0738	.3125	2.5	IT-2301000	47.95	IT-2301000X	55.20
NEW 10-48	.230	.252	1.250	.032	.055	.002	.0738	.3125	2.5	IT-2301250	47.95	IT-2301250X	55.20
10-48	.230	.252	1.500	.032	.055	.002	.0738	.3125	2.5	IT-2301500	47.95	IT-2301500X	55.20
8-40	.290	.312	.500	.040	.070	.002	.1338	.3125	2.5	IT-290500	47.95	IT-290500X	55.20
8-40	.290	.312	.750	.040	.070	.002	.1338	.3125	2.5	IT-290750	47.95	IT-290750X	55.20
8-40	.290	.312	1.000	.040	.070	.002	.1338	.3125	2.5	IT-2901000	47.95	IT-2901000X	55.20
NEW 8-40	.290	.312	1.250	.040	.070	.002	.1338	.3125	2.5	IT-2901250	47.95	IT-2901250X	55.20
NEW 8-40	.290	.312	1.500	.040	.070	.002	.1338	.3125	2.5	IT-2901500	47.95	IT-2901500X	55.20
8-40	.290	.312	1.750	.040	.070	.002	.1338	.3125	2.5	IT-2901750	47.95	IT-2901750X	55.20
8-40	.320	.342	.500	.043	.075	.002	.1325	.3750	2.5	IT-320500	62.45	IT-320500X	71.05
8-40	.320	.342	.750	.043	.075	.002	.1325	.3750	2.5	IT-320750	62.45	IT-320750X	71.05
8-40	.320	.342	1.000	.043	.075	.002	.1325	.3750	2.5	IT-3201000	62.45	IT-3201000X	71.05
NEW 8-40	.320	.342	1.250	.043	.075	.002	.1325	.3750	2.5	IT-3201250	62.45	IT-3201250X	71.05
NEW 8-40	.320	.342	1.500	.043	.075	.002	.1325	.3750	2.5	IT-3201500	62.45	IT-3201500X	71.05
NEW 8-40	.320	.342	1.750	.043	.075	.002	.1325	.3750	3.0	IT-3201750	63.95	IT-3201750X	72.55
8-40	.320	.342	1.800	.043	.075	.002	.1325	.3750	2.5	IT-3201800	62.45	IT-3201800X	71.05

*Suggested Minimum Bore Diameter to accommodate chip evacuation and retract clearance in static (not live) applications.

Continued on next page

Standard – Threading Tools



Standard – Threading Tools

IT

UN Threads – Single Point – Right Hand (cont.)

Continued from previous page

Threads Per Inch	Head Width	Minimum Bore Diameter*	Maximum Bore Depth	Point Offset	Projection	Radius	Centerline Offset	Shank Dia.	Overall Length	Uncoated		AlTiN Coated	
										Tool #	Price	Tool #	Price
TPI	H		L ₂ ^{+.050"} _{-.000"}	Y ^{+.010"} _{-.000"}	P	R ^{+.001"} _{-.001"}	F	D ₂ (h6)	L ₁				
7-32	.360	.382	.500	.049	.085	.002	.1725	.3750	2.5	IT-360500	62.45	IT-360500X	71.05
7-32	.360	.382	.750	.049	.085	.002	.1725	.3750	2.5	IT-360750	62.45	IT-360750X	71.05
7-32	.360	.382	1.000	.049	.085	.002	.1725	.3750	2.5	IT-3601000	62.45	IT-3601000X	71.05
7-32	.360	.382	1.250	.049	.085	.002	.1725	.3750	2.5	IT-3601250	62.45	IT-3601250X	71.05
7-32	.360	.382	1.500	.049	.085	.002	.1725	.3750	2.5	IT-3601500	62.45	IT-3601500X	71.05
7-32	.360	.382	1.750	.049	.085	.002	.1725	.3750	3.0	IT-3601750	63.95	IT-3601750X	72.55
7-32	.360	.382	1.800	.049	.085	.002	.1725	.3750	2.5	IT-3601800	62.45	IT-3601800X	71.05
5-32	.460	.482	.750	.069	.120	.002	.2100	.5000	3.0	IT-460750	63.95	IT-460750X	75.65
5-32	.460	.482	1.500	.069	.120	.002	.2100	.5000	3.0	IT-4601500	63.95	IT-4601500X	75.65
5-32	.460	.482	2.000	.069	.120	.002	.2100	.5000	3.0	IT-4602000	87.60	IT-4602000X	99.30
5-32	.490	.512	.750	.069	.120	.002	.2400	.5000	3.0	IT-490750	87.60	IT-490750X	99.30
5-32	.490	.512	1.125	.069	.120	.002	.2400	.5000	3.0	IT-4901125	87.60	IT-4901125X	99.30
5-32	.490	.512	1.500	.069	.120	.002	.2400	.5000	3.0	IT-4901500	87.60	IT-4901500X	99.30
5-32	.490	.512	2.000	.069	.120	.002	.2400	.5000	3.0	IT-4902000	87.60	IT-4902000X	99.30

*Suggested Minimum Bore Diameter to accommodate chip evacuation and retract clearance in static (not live) applications.

ITL

Standard - Threading Tools
UN Threads - Single Point - Left Hand

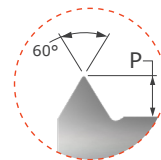
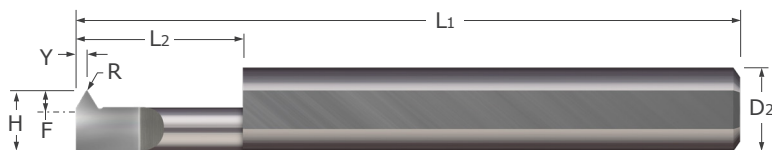

- Designed for threading multiple thread pitches (ANSI, UN, and Metric 60°) in a left hand threading application
- Polished split face for improved edge retention and chip evacuation while reducing galling
- Split face geometry provides optimal edge strength
- Corner radius profile
- Lockdown flat automatically locates tool on center
- AlTiN coated option provides added lubricity and increased wear resistance in difficult to machine materials
- Solid carbide ■ CNC ground in the USA

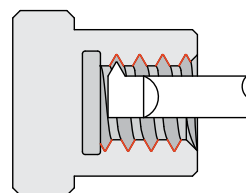

Threads Per Inch	Head Width	Minimum Bore Diameter*	Maximum Bore Depth	Point Offset	Projection	Radius	Centerline Offset	Shank Dia.	Overall Length	Uncoated		AlTiN Coated	
										Tool #	Price	Tool #	Price
TPI	H		L2	Y	P	R	F	D2 (h6)	L1	Tool #	Price	Tool #	Price
40-72	.040	.045	.075	.009	.015	.001	-.0225	.1250	1.5	ITL-040075	42.40		
40-72	.040	.045	.150	.009	.015	.001	-.0225	.1250	1.5	ITL-040150	42.40		
28-72	.050	.055	.200	.012	.020	.001	-.0125	.1250	1.5	ITL-050200	42.40	ITL-050200X	46.60
28-56	.060	.070	.200	.012	.020	.001	-.0025	.1250	1.5	ITL-060200	36.95	ITL-060200X	41.15
28-56	.060	.070	.250	.012	.020	.001	-.0025	.1250	1.5	ITL-060250	36.95	ITL-060250X	41.15
28-56	.060	.070	.300	.012	.020	.001	-.0025	.1250	1.5	ITL-060300	36.95	ITL-060300X	41.15

TPI	H	L2	Y	P	R	F	D2 (h6)	L1	Tool #	Price	Tool #	Price	
28-56	.080	.090	.250	.012	.020	.002	.0175	.1250	1.5	ITL-080250	33.70	ITL-080250X	37.80
28-56	.080	.090	.350	.012	.020	.002	.0175	.1250	1.5	ITL-080350	33.70	ITL-080350X	37.80
28-56	.080	.090	.500	.012	.020	.002	.0175	.1250	1.5	ITL-080500	33.70	ITL-080500X	37.80
24-56	.100	.110	.250	.014	.025	.002	.0375	.1250	1.5	ITL-100250	33.70	ITL-100250X	37.80
24-56	.100	.110	.350	.014	.025	.002	.0375	.1250	1.5	ITL-100350	33.70	ITL-100350X	37.80
24-56	.100	.110	.500	.014	.025	.002	.0375	.1250	1.5	ITL-100500	33.70	ITL-100500X	37.80
24-56	.100	.110	.600	.014	.025	.002	.0375	.1250	1.5	ITL-100600	33.70	ITL-100600X	37.80
20-56	.120	.136	.250	.017	.030	.002	.0263	.1875	2.0	ITL-120250	35.90	ITL-120250X	40.50
20-56	.120	.136	.400	.017	.030	.002	.0263	.1875	2.0	ITL-120400	35.90	ITL-120400X	40.50
20-56	.120	.136	.500	.017	.030	.002	.0263	.1875	2.0	ITL-120500	35.90	ITL-120500X	40.50
20-56	.120	.136	.600	.017	.030	.002	.0263	.1875	2.0	ITL-120600	35.90	ITL-120600X	40.50
20-56	.120	.136	.750	.017	.030	.002	.0263	.1875	2.0	ITL-120750	35.90	ITL-120750X	40.50
16-56	.140	.156	.250	.020	.035	.002	.0463	.1875	2.0	ITL-140250	35.90	ITL-140250X	40.50
16-56	.140	.156	.400	.020	.035	.002	.0463	.1875	2.0	ITL-140400	35.90	ITL-140400X	40.50
16-56	.140	.156	.500	.020	.035	.002	.0463	.1875	2.0	ITL-140500	35.90	ITL-140500X	40.50
16-56	.140	.156	.750	.020	.035	.002	.0463	.1875	2.0	ITL-140750	35.90	ITL-140750X	40.50

*Suggested Minimum Bore Diameter to accommodate chip evacuation and retract clearance in static (not live) applications.

Continued on next page

See pgs 33-37 for standard tool holders



Standard – Threading Tools

ITL

UN Threads – Single Point – Left Hand (cont.)

Continued from previous page

Threads Per Inch	Head Width	Minimum Bore Diameter*	Maximum Bore Depth	Point Offset	Projection	Radius	Centerline Offset	Shank Dia.	Overall Length	Uncoated		AlTiN Coated	
										Tool #	Price	Tool #	Price
TPI	H	L ₂	$^{+.050}_{-.000}$ "	$^{+.010}_{-.000}$ "	P	$R^{+.001}_{-.001}$ "	F	D ₂ (h6)	L ₁	Tool #	Price	Tool #	Price
14-56	.160	.182	.250	.023	.040	.002	.0663	.1875	2.0	ITL-160250	35.90	ITL-160250X	40.50
14-56	.160	.182	.400	.023	.040	.002	.0663	.1875	2.0	ITL-160400	35.90	ITL-160400X	40.50
14-56	.160	.182	.500	.023	.040	.002	.0663	.1875	2.0	ITL-160500	35.90	ITL-160500X	40.50
14-56	.160	.182	.750	.023	.040	.002	.0663	.1875	2.0	ITL-160750	35.90	ITL-160750X	40.50
14-56	.180	.202	.350	.023	.040	.002	.0550	.2500	2.5	ITL-180350	38.30	ITL-180350X	44.35
14-56	.180	.202	.500	.023	.040	.002	.0550	.2500	2.5	ITL-180500	38.30	ITL-180500X	44.35
14-56	.180	.202	.750	.023	.040	.002	.0550	.2500	2.5	ITL-180750	38.30	ITL-180750X	44.35
14-56	.180	.202	1.000	.023	.040	.002	.0550	.2500	2.5	ITL-1801000	38.30	ITL-1801000X	44.35
13-56	.200	.222	.400	.026	.045	.002	.0750	.2500	2.5	ITL-200400	38.30	ITL-200400X	44.35
13-56	.200	.222	.600	.026	.045	.002	.0750	.2500	2.5	ITL-200600	38.30	ITL-200600X	44.35
13-56	.200	.222	.750	.026	.045	.002	.0750	.2500	2.5	ITL-200750	38.30	ITL-200750X	44.35
13-56	.200	.222	1.000	.026	.040	.002	.0750	.2500	2.5	ITL-2001000	38.30	ITL-2001000X	44.35
10-48	.230	.252	.400	.032	.055	.002	.0738	.3125	2.5	ITL-230400	47.95	ITL-230400X	55.20
10-48	.230	.252	.600	.032	.055	.002	.0738	.3125	2.5	ITL-230600	47.95	ITL-230600X	55.20
10-48	.230	.252	.750	.032	.055	.002	.0738	.3125	2.5	ITL-230750	47.95	ITL-230750X	55.20
10-48	.230	.252	1.000	.032	.055	.002	.0738	.3125	2.5	ITL-2301000	47.95	ITL-2301000X	55.20
8-40	.290	.312	.500	.040	.070	.002	.1338	.3125	2.5	ITL-290500	47.95	ITL-290500X	55.20
8-40	.290	.312	.750	.040	.070	.002	.1338	.3125	2.5	ITL-290750	47.95	ITL-290750X	55.20
8-40	.290	.312	1.000	.040	.070	.002	.1338	.3125	2.5	ITL-2901000	47.95	ITL-2901000X	55.20
8-40	.290	.312	1.250	.040	.070	.002	.1338	.3125	2.5	ITL-2901250	47.95	ITL-2901250X	55.20
8-40	.320	.342	.500	.043	.075	.002	.1325	.3750	2.5	ITL-320500	62.45	ITL-320500X	71.05
8-40	.320	.342	.750	.043	.075	.002	.1325	.3750	2.5	ITL-320750	62.45	ITL-320750X	71.05
8-40	.320	.342	1.000	.043	.075	.002	.1325	.3750	2.5	ITL-3201000	62.45	ITL-3201000X	71.05
8-40	.320	.342	1.250	.043	.075	.002	.1325	.3750	2.5	ITL-3201250	62.45	ITL-3201250X	71.05
7-32	.360	.382	.500	.049	.085	.002	.1725	.3750	2.5	ITL-360500	62.45	ITL-360500X	71.05
7-32	.360	.382	.750	.049	.085	.002	.1725	.3750	2.5	ITL-360750	62.45	ITL-360750X	71.05
7-32	.360	.382	1.000	.049	.085	.002	.1725	.3750	2.5	ITL-3601000	62.45	ITL-3601000X	71.05
7-32	.360	.382	1.250	.049	.085	.002	.1725	.3750	2.5	ITL-3601250	62.45	ITL-3601250X	71.05
7-32	.360	.382	1.800	.049	.085	.002	.1725	.3750	2.5	ITL-3601800	62.45	ITL-3601800X	71.05
5-32	.490	.512	.750	.069	.120	.002	.2400	.5000	3.0	ITL-490750	87.60	ITL-490750X	99.30
5-32	.490	.512	1.500	.069	.120	.002	.2400	.5000	3.0	ITL-4901500	87.60	ITL-4901500X	99.30
5-32	.490	.512	2.000	.069	.120	.002	.2400	.5000	3.0	ITL-4902000	87.60	ITL-4902000X	99.30

*Suggested Minimum Bore Diameter to accommodate chip evacuation and retract clearance in static (not live) applications.

Standard – Threading Tools

See pgs 33-37 for standard tool holders

ITM

Standard – Threading Tools
Metric Shank – Single Point – Right Hand

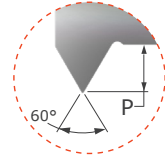
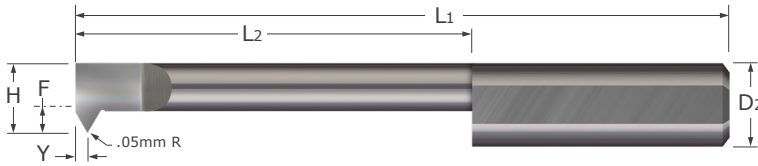

- Designed for threading multiple thread pitches (ANSI, UN, & Metric 60°)
- Polished split face for improved edge retention and chip evacuation while reducing galling
- Split face geometry provides optimal edge strength
- Corner radius profile
- Lockdown flat automatically locates tool on center
- AlTiN coated option provides added lubricity and increased wear resistance in difficult to machine materials
- Solid carbide ■ CNC ground in the USA

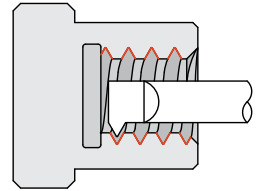

Pitch	Head Width	Minimum Bore Diameter*	Max. Bore Depth	Point Offset	Projection	Centerline Offset	Shank Dia.	OAL	Uncoated		TiN Coated		AlTiN Coated	
									Tool #	Price	Tool #	Price	Tool #	Price
	H	L_2	$+1.24mm$ $-0.00mm$	$+0.25mm$ $-0.00mm$	P	F	D ₂ (h6)	L ₁						
.75-2.0 mm	4.60 mm	5.15 mm	13 mm	0.71 mm	1.22 mm	1.6 mm	6 mm	57 mm	ITM-064613	37.80	ITM-064613G	43.00	ITM-064613X	43.85
.75-2.0 mm	4.60 mm	5.15 mm	25 mm	0.71 mm	1.22 mm	1.6 mm	6 mm	57 mm	ITM-064625	37.80	ITM-064625G	43.00	ITM-064625X	43.85
.75-2.0 mm	5.10 mm	5.65 mm	15 mm	0.76 mm	1.32 mm	2.1 mm	6 mm	57 mm	ITM-065115	37.80			ITM-065115X	43.85
.75-2.0 mm	5.10 mm	5.65 mm	28 mm	0.76 mm	1.32 mm	2.1 mm	6 mm	57 mm	ITM-065128	37.80			ITM-065128X	43.85
.75-2.5 mm	5.80 mm	6.35 mm	15 mm	0.86 mm	1.50 mm	1.8 mm	8 mm	63 mm	ITM-085815	45.60			ITM-085815X	54.20
.75-2.5 mm	5.80 mm	6.35 mm	25 mm	0.86 mm	1.50 mm	1.8 mm	8 mm	63 mm	ITM-085825	45.60			ITM-085825X	54.20
.75-2.5 mm	5.80 mm	6.35 mm	38 mm	0.86 mm	1.50 mm	1.8 mm	8 mm	63 mm	ITM-085838	45.60			ITM-085838X	54.20
.75-3.5 mm	7.40 mm	7.95 mm	20 mm	1.09 mm	1.91 mm	3.4 mm	8 mm	63 mm	ITM-087420	45.60	ITM-087420G	52.85		
.75-3.5 mm	7.40 mm	7.95 mm	32 mm	1.09 mm	1.91 mm	3.4 mm	8 mm	63 mm	ITM-087432	45.60	ITM-087432G	52.85	ITM-087432X	54.20
.75-3.5 mm	7.40 mm	7.95 mm	46 mm	1.09 mm	1.91 mm	3.4 mm	8 mm	63 mm	ITM-087446	45.60	ITM-087446G	52.85	ITM-087446X	54.20
1.0-3.5 mm	9.60 mm	10.15 mm	20 mm	1.40 mm	2.41 mm	4.6 mm	10 mm	72 mm	ITM-109620	63.95				
1.0-3.5 mm	11.40 mm	11.95 mm	50 mm	1.85 mm	3.23 mm	5.4 mm	12 mm	83 mm	ITM-121150	82.00				

*Suggested Minimum Bore Diameter to accommodate chip evacuation and retract clearance in static (not live) applications.

Standard – Threading Tools

UN Topping – Single Point

TT

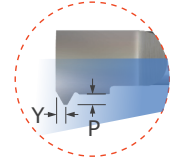
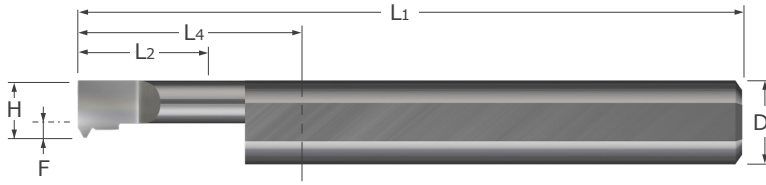

- Designed for threading 60° UN pitches in a right hand topping application
- Topping design generates a controlled thread height with a reduction in burr formation
- Polished split face for improved edge retention and chip evacuation while reducing galling
- Split face geometry provides optimal edge strength
- Corner radius profile
- Lockdown flat automatically locates tool on center
- AlTiN coated option provides added lubricity and increased wear resistance in difficult to machine materials
- Solid carbide ■ CNC ground in the USA

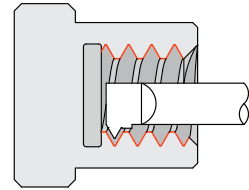

Standard – Threading Tools

Threads Size	Head Width	Minimum Bore Diameter*	Maximum Bore Depth	Point Offset	Projection	Centerline Offset	Shank Dia.	Overall Length	Uncoated		AlTiN Coated		
									H	L2	Y	P	F
2-56	.050	.055	.150	.012	.0097	-.0125	.1250	1.5	TT-000256-015	43.25	TT-000256-015X	47.45	NEW
2-56	.050	.055	.200	.012	.0097	-.0125	.1250	1.5	TT-000256-020	43.25	TT-000256-020X	47.45	NEW
4-40	.065	.075	.200	.014	.0135	.0025	.1250	1.5	TT-000440-020	43.25	TT-000440-020X	47.45	NEW
4-40	.065	.075	.250	.014	.0135	.0025	.1250	1.5	TT-000440-025	34.30	TT-000440-025X	38.50	NEW
5-44	.080	.090	.200	.014	.0123	.0175	.1250	1.5	TT-000544-020	34.30	TT-000544-020X	38.50	NEW
5-44	.080	.090	.250	.014	.0123	.0175	.1250	1.5	TT-000544-025	34.30	TT-000544-025X	38.50	NEW
6-32	.080	.090	.250	.017	.0169	.0175	.1250	1.5	TT-000632-025	34.30	TT-000632-025X	38.50	NEW
6-32	.080	.090	.350	.017	.0169	.0175	.1250	1.5	TT-000632-035	34.30	TT-000632-035X	38.50	NEW
8-32	.100	.110	.250	.017	.0169	.0375	.1250	1.5	TT-000832-025	34.30	TT-000832-025X	38.50	NEW
8-32	.100	.110	.350	.017	.0169	.0375	.1250	1.5	TT-000832-035	34.30	TT-000832-035X	38.50	NEW
10-24	.120	.136	.250	.021	.0226	.0263	.1875	1.5	TT-001024-025	36.60	TT-001024-025X	41.35	NEW
10-24	.120	.136	.400	.021	.0226	.0263	.1875	1.5	TT-001024-040	36.60	TT-001024-040X	41.35	NEW
10-32	.120	.136	.250	.017	.0169	.0263	.1875	1.5	TT-001032-025	36.60	TT-001032-025X	41.35	NEW
10-32	.120	.136	.400	.017	.0169	.0263	.1875	1.5	TT-001032-040	36.60	TT-001032-040X	41.35	NEW
1/4-20	.160	.182	.400	.024	.0271	.0663	.1875	1.5	TT-014020-040	36.60	TT-014020-040X	41.35	NEW
1/4-20	.160	.182	.500	.024	.0271	.0663	.1875	1.5	TT-014020-050	36.60	TT-014020-050X	41.35	NEW
1/4-28	.180	.202	.500	.018	.0193	.0550	.2500	2.0	TT-014028-050	39.10	TT-014028-050X	44.75	NEW
1/4-28	.180	.202	.750	.018	.0193	.0550	.2500	2.0	TT-014028-075	39.10	TT-014028-075X	44.75	NEW
5/16-18	.220	.242	.750	.026	.0301	.0638	.3125	2.0	TT-051618-075	48.90	TT-051618-075X	55.75	NEW
5/16-18	.220	.242	1.000	.026	.0301	.0638	.3125	2.0	TT-051618-100	48.90	TT-051618-100X	55.75	NEW
5/16-24	.220	.242	.750	.021	.0226	.0638	.3125	2.0	TT-051624-075	48.90	TT-051624-075X	55.75	NEW
5/16-24	.220	.242	1.000	.021	.0226	.0638	.3125	2.0	TT-051624-100	48.90	TT-051624-100X	55.75	NEW
3/8-16	.280	.302	.750	.028	.0338	.1238	.3125	2.0	TT-038016-075	48.90	TT-038016-075X	55.75	NEW
3/8-16	.280	.302	1.000	.028	.0338	.1238	.3125	2.0	TT-038016-100	48.90	TT-038016-100X	55.75	NEW
3/8-24	.300	.322	.750	.021	.0226	.1438	.3125	2.0	TT-038024-075	48.90	TT-038024-075X	55.75	NEW
3/8-24	.300	.322	1.000	.021	.0226	.1438	.3125	2.0	TT-038024-100	48.90	TT-038024-100X	55.75	NEW

*Suggested Minimum Bore Diameter to accommodate chip evacuation and retract clearance in static (not live) applications.

Continued on next page

See pgs 33-37 for standard tool holders

TT

Standard – Threading Tools
UN Topping – Single Point (cont.)

Continued from previous page

	Threads Size	Head Width	Minimum Bore Diameter*	Maximum Bore Depth	Point Offset	Projection	Centerline Offset	Shank Dia.	Overall Length	Uncoated		AlTiN Coated	
										Tool #	Price	Tool #	Price
		H	L ₂	$^{+.050"}_{-.000"} Y$	$^{+.005"}_{-.000"} Y$	$^{+.000"}_{-.002"} P$	F	D ₂ (h6)	L ₁				
NEW	7/16-14	.310	.332	.750	.032	.0387	.1538	.3125	2.0	TT-071614-075	48.90	TT-071614-075X	55.75
NEW	7/16-14	.310	.332	1.000	.032	.0387	.1538	.3125	2.0	TT-071614-100	48.90	TT-071614-100X	55.75
NEW	7/16-20	.350	.372	1.000	.024	.0271	.1625	.3750	2.0	TT-071620-100	63.75	TT-071620-100X	71.85
NEW	7/16-20	.350	.372	1.250	.024	.0271	.1625	.3750	2.5	TT-071620-125	63.75	TT-071620-125X	72.35
NEW	1/2-13	.380	.402	1.000	.034	.0416	.1300	.5000	3.0	TT-012013-100	89.35	TT-012013-100X	101.05
NEW	1/2-13	.380	.402	1.250	.034	.0416	.1300	.5000	3.0	TT-012013-125	89.35	TT-012013-125X	101.05
NEW	1/2-20	.410	.432	1.000	.024	.0271	.1600	.5000	3.0	TT-012020-100	89.35	TT-012020-100X	101.05
NEW	1/2-20	.410	.432	1.250	.024	.0271	.1600	.5000	3.0	TT-012020-125	89.35	TT-012020-125X	101.05
NEW	9/16-12	.410	.432	1.000	.036	.0451	.1600	.5000	3.0	TT-091612-100	89.35	TT-091612-100X	101.05
NEW	9/16-12	.410	.432	1.250	.036	.0451	.1600	.5000	3.0	TT-091612-125	89.35	TT-091612-125X	101.05
NEW	9/16-18	.460	.482	1.000	.026	.0301	.2100	.5000	3.0	TT-091618-100	89.35	TT-091618-100X	101.05
NEW	9/16-18	.460	.482	1.250	.026	.0301	.2100	.5000	3.0	TT-091618-125	89.35	TT-091618-125X	101.05
NEW	5/8-11	.490	.512	1.000	.039	.0492	.2400	.5000	3.0	TT-058011-100	89.35	TT-058011-100X	101.05
NEW	5/8-11	.490	.512	1.250	.039	.0492	.2400	.5000	3.0	TT-058011-125	89.35	TT-058011-125X	101.05
NEW	3/4-16	.490	.512	1.000	.028	.0338	.2400	.5000	3.0	TT-034016-100	89.35	TT-034016-100X	101.05
NEW	3/4-16	.490	.512	1.250	.028	.0338	.2400	.5000	3.0	TT-034016-125	89.35	TT-034016-125X	101.05

*Suggested Minimum Bore Diameter to accommodate chip evacuation and retract clearance in static (not live) applications.

Standard – Threading Tools

Standard – Threading Tools

Metric Topping – Single Point

TMT

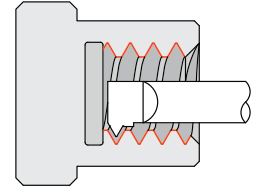
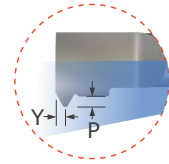
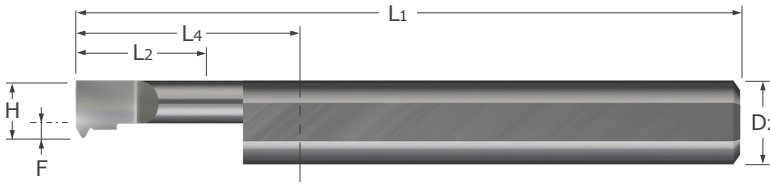

- Designed for threading 60° Metric pitches in a right hand topping application
- Topping design generates a controlled thread height with a reduction in burr formation
- Polished split face for improved edge retention and chip evacuation while reducing galling
- Split face geometry provides optimal edge strength
- Lockdown flat automatically locates tool on center
- AlTiN coated option provides added lubricity and increased wear resistance in difficult to machine materials
- Solid carbide ■ CNC ground in the USA

Threads Size	Head Width	Minimum Bore Diameter*	Maximum Bore Depth	Point Offset	Projection	Centerline Offset	Shank Dia.	Overall Length	Uncoated		AlTiN Coated	
									Tool #	Price	Tool #	Price
	H		L2	Y	P	F	D2 (h6)	L1				
			+1.27mm -.000mm	+ .127mm -.000mm	+ .000mm -.051mm							
M2.5x0.45	1.50 mm	1.70 mm	5.00 mm	.300 mm	.244 mm	-0.09 mm	.1250	1.5	TMT-025045-05	43.25	TMT-025045-05X	47.45
M2.5x0.45	1.50 mm	1.70 mm	7.00 mm	.300 mm	.244 mm	-0.09 mm	.1250	1.5	TMT-025045-07	43.25	TMT-025045-07X	47.45
M3x0.50	2.00 mm	2.20 mm	6.00 mm	.319 mm	.271 mm	0.41 mm	.1250	1.5	TMT-030050-06	34.30	TMT-030050-06X	38.50
M3x0.50	2.00 mm	2.20 mm	8.00 mm	.319 mm	.271 mm	0.41 mm	.1250	1.5	TMT-030050-08	34.30	TMT-030050-08X	38.50
M4x0.70	2.50 mm	2.70 mm	7.00 mm	.396 mm	.379 mm	0.91 mm	.1250	1.5	TMT-040070-07	34.30	TMT-040070-07X	38.50
M4x0.70	2.50 mm	2.70 mm	10.00 mm	.396 mm	.379 mm	0.91 mm	.1250	1.5	TMT-040070-10	34.30	TMT-040070-10X	38.50
M4.5x0.75	3.00 mm	3.40 mm	6.00 mm	.415 mm	.406 mm	0.62 mm	.1875	1.5	TMT-045075-06	36.60	TMT-045075-06X	40.80
M4.5x0.75	3.00 mm	3.40 mm	9.00 mm	.415 mm	.406 mm	0.62 mm	.1875	1.5	TMT-045075-09	36.60	TMT-045075-09X	40.80
M5x0.80	3.00 mm	3.40 mm	6.00 mm	.434 mm	.433 mm	0.62 mm	.1875	1.5	TMT-050080-06	36.60	TMT-050080-06X	40.80
M5x0.80	3.00 mm	3.40 mm	9.00 mm	.434 mm	.433 mm	0.62 mm	.1875	1.5	TMT-050080-09	36.60	TMT-050080-09X	40.80
M6x1.00	4.00 mm	4.50 mm	10.00 mm	.511 mm	.541 mm	1.62 mm	.1875	1.5	TMT-060100-10	36.60	TMT-060100-10X	40.80
M6x1.00	4.00 mm	4.50 mm	14.00 mm	.511 mm	.541 mm	1.62 mm	.1875	2.0	TMT-060100-14	37.75	TMT-060100-14X	41.95
M8x1.25	5.50 mm	6.00 mm	14.00 mm	.607 mm	.677 mm	1.53 mm	.3125	2.0	TMT-080125-14	48.90	TMT-080125-14X	53.10
M8x1.25	5.50 mm	6.00 mm	22.00 mm	.607 mm	.677 mm	1.53 mm	.3125	2.0	TMT-080125-22	48.90	TMT-080125-22X	53.10
M10x1.50	7.50 mm	8.00 mm	24.00 mm	.703 mm	.812 mm	3.53 mm	.3125	2.0	TMT-100150-24	48.90	TMT-100150-24X	53.10
M10x1.50	7.50 mm	8.00 mm	31.00 mm	.703 mm	.812 mm	3.53 mm	.3125	2.5	TMT-100150-31	48.90	TMT-100150-31X	53.10
M12x1.75	9.00 mm	9.50 mm	22.00 mm	.804 mm	.957 mm	4.24 mm	.3750	2.0	TMT-120175-22	63.75	TMT-120175-22X	67.95
M12x1.75	9.00 mm	9.50 mm	31.00 mm	.804 mm	.957 mm	4.24 mm	.3750	2.5	TMT-120175-31	64.90	TMT-120175-31X	69.10
M16x2.00	12.50 mm	13.00 mm	31.00 mm	.896 mm	1.085 mm	6.15 mm	.5000	3.0	TMT-160200-31	89.35	TMT-160200-31X	93.55
M16x2.00	12.50 mm	13.00 mm	44.00 mm	.896 mm	1.085 mm	6.15 mm	.5000	3.0	TMT-160200-44	89.35	TMT-160200-44X	93.55
M20x2.50	12.50 mm	13.00 mm	31.00 mm	1.086 mm	1.353 mm	6.15 mm	.5000	3.0	TMT-200250-31	89.35	TMT-200250-31X	93.55
M20x2.50	12.50 mm	13.00 mm	44.00 mm	1.086 mm	1.353 mm	6.15 mm	.5000	3.0	TMT-200250-44	89.35	TMT-200250-44X	93.55

*Suggested Minimum Bore Diameter to accommodate chip evacuation and retract clearance in static (not live) applications.

Standard – Threading Tools

See pgs 33-37 for standard tool holders

IAT

Standard – Threading Tools

ACME Threads

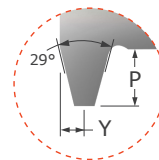
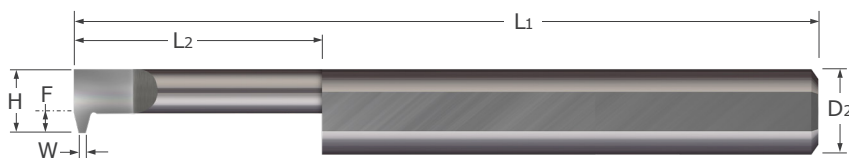

- Designed for cutting pitch-specific ACME threads
- Polished split face for improved edge retention and chip evacuation while reducing galling
- Split face geometry provides optimal edge strength
- Lockdown flat automatically locates tool on center
- AlTiN coated option provides added lubricity and increased wear resistance in difficult to machine materials
- Solid carbide ■ CNC ground in the USA

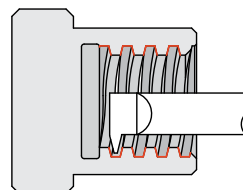

	Threads Per Inch	Head Width	Minimum Bore Diameter*	Maximum Bore Depth	Point Offset	Projection	Flat	Centerline Offset	Shank Diameter	Overall Length	Uncoated		AlTiN Coated	
											Tool #	Price	Tool #	Price
	TPI	H		L2 ^{+0.050"} / _{-.000"}	Y	P	W ^{+0.000"} / _{-.005"}	F	D2 (h6)	L1				
NEW	16	.165	.187	.400	.035	.045	.021	.0400	.2500	2.5	IAT2-400-16	38.30		
NEW	16	.165	.187	.600	.024	.050	.021	.0400	.2500	2.5	IAT2-600-16	38.30		
NEW	16	.165	.187	.750	.035	.045	.021	.0400	.2500	2.5	IAT2-750-16	38.30		
NEW	16	.165	.187	1.000	.035	.045	.021	.0400	.2500	2.5	IAT2-1000-16	38.30		
	16	.200	.222	.400	.035	.045	.021	.0750	.2500	2.5	IAT-400-16	38.30	IAT-400-16X	44.35
	16	.200	.222	.600	.024	.045	.021	.0750	.2500	2.5	IAT-600-16	38.30	IAT-600-16X	44.35
	16	.200	.222	.750	.035	.045	.021	.0750	.2500	2.5	IAT-750-16	38.30	IAT-750-16X	44.35
	16	.200	.222	1.000	.035	.045	.021	.0750	.2500	2.5	IAT-1000-16	38.30	IAT-1000-16X	44.35
NEW	14	.219	.241	.500	.043	.070	.024	.0627	.3125	2.5	IAT2-500-14	47.40		
NEW	14	.219	.241	.750	.030	.070	.024	.0627	.3125	2.5	IAT2-750-14	47.40		
NEW	14	.219	.241	1.000	.043	.070	.024	.0627	.3125	2.5	IAT2-1000-14	47.40		
NEW	14	.219	.241	1.250	.043	.070	.024	.0627	.3125	2.5	IAT2-1250-14	47.40		
	14	.255	.277	.500	.043	.070	.024	.0988	.3125	2.5	IAT-500-14	47.40	IAT-500-14X	54.65
	14	.255	.277	.750	.030	.070	.024	.0988	.3125	2.5	IAT-750-14	47.40	IAT-750-14X	54.65
	14	.255	.277	1.000	.043	.070	.024	.0988	.3125	2.5	IAT-1000-14	47.40	IAT-1000-14X	54.65
	14	.255	.277	1.250	.043	.070	.024	.0988	.3125	2.5	IAT-1250-14	47.40	IAT-1250-14X	54.65
NEW	12	.269	.291	.750	.049	.085	.028	.0815	.3750	2.5	IAT2-750-12	62.45		
NEW	12	.269	.291	1.000	.036	.085	.028	.0815	.3750	2.5	IAT2-1000-12	62.45		
NEW	12	.269	.291	1.250	.049	.085	.028	.0815	.3750	2.5	IAT2-1250-12	62.45		
NEW	12	.269	.291	1.800	.049	.085	.028	.0815	.3750	4.0	IAT2-1800-12	62.45		
	12	.360	.382	.750	.049	.085	.028	.1725	.3750	2.5	IAT-750-12	62.45	IAT-750-12X	71.05
	12	.360	.382	1.000	.036	.085	.028	.1725	.3750	2.5	IAT-1000-12	62.45	IAT-1000-12X	71.05
	12	.360	.382	1.250	.049	.085	.028	.1725	.3750	2.5	IAT-1250-12	62.45	IAT-1250-12X	71.05
	12	.360	.382	1.800	.049	.085	.028	.1725	.3750	2.5	IAT-1800-12	62.45	IAT-1800-12X	71.05
NEW	10	.373	.395	.750	.060	.110	.032	.1230	.5000	3.0	IAT2-750-10	87.60		
NEW	10	.378	.400	1.500	.060	.120	.032	.1280	.5000	3.0	IAT2-1500-10	87.60		
NEW	10	.378	.400	2.000	.060	.120	.032	.1280	.5000	3.0	IAT2-2000-10	87.60		
	10	.490	.512	.750	.060	.120	.032	.2400	.5000	3.0	IAT-750-10	87.60	IAT-750-10X	99.30
	10	.490	.512	1.500	.060	.120	.032	.2400	.5000	3.0	IAT-1500-10	87.60	IAT-1500-10X	99.30
	10	.490	.512	2.000	.060	.120	.032	.2400	.5000	3.0	IAT-2000-10	87.60	IAT-2000-10X	99.30

*Suggested Minimum Bore Diameter to accommodate chip evacuation and retract clearance in static (not live) applications.

Continued on next page

See pgs 33-37 for standard tool holders

Standard – Threading Tools

IAT

ACME Threads (cont.)

Continued from previous page

Threads Per Inch	Head Width	Minimum Bore Diameter*	Maximum Bore Depth	Point Offset	Projection	Flat	Centerline Offset	Shank Diameter	Overall Length	Uncoated		AITIN Coated	
										Tool #	Price	Tool #	Price
TPI	H		L ₂	Y	P	W	F	D ₂ (h6)	L ₁				
			$^{+.050"}_{-.000"}$			$^{+.000"}_{-.005"}$							
8	.478	.500	.750	.064	.120	.041	.2280	.5000	3.0	IAT2-750-8	87.60		
8	.478	.500	1.500	.064	.120	.041	.2280	.5000	3.0	IAT2-1500-8	87.60		
8	.478	.500	2.000	.064	.120	.041	.2280	.5000	3.0	IAT2-2000-8	87.60		
8	.490	.512	.750	.064	.120	.041	.2400	.5000	3.0	IAT-750-8	87.60	IAT-750-8X	99.30
8	.490	.512	1.500	.064	.120	.041	.2400	.5000	3.0	IAT-1500-8	87.60	IAT-1500-8X	99.30
8	.490	.512	2.000	.064	.120	.041	.2400	.5000	3.0	IAT-2000-8	87.60	IAT-2000-8X	99.30
6	.490	.512	.750	.072	.120	.057	.2400	.5000	3.0	IAT-750-6	87.60	IAT-750-6X	99.30
6	.490	.512	1.500	.072	.120	.057	.2400	.5000	3.0	IAT-1500-6	87.60	IAT-1500-6X	99.30
6	.490	.512	2.000	.072	.120	.057	.2400	.5000	3.0	IAT-2000-6	87.60	IAT-2000-6X	99.30
5	.490	.512	1.500	.078	.120	.069	.2400	.5000	3.0	IAT-1500-5	87.60	IAT-1500-5X	99.30
5	.490	.512	2.000	.078	.120	.069	.2400	.5000	3.0	IAT-2000-5	87.60	IAT-2000-5X	99.30

NEW
NEW
NEW

*Suggested Minimum Bore Diameter to accommodate chip evacuation and retract clearance in static (not live) applications.

Standard – Threading Tools

Technical Resources on Micro100.com

Find Simulation Files, Speeds & Feeds, Torque Recommendations, Programs, Blogs, and more at [micro100.com/resources](https://Micro100.com/resources)

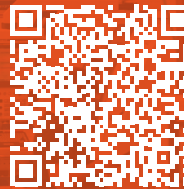

SAT

Standard – Threading Tools

Stub ACME Threads

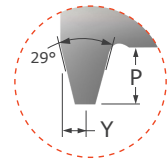
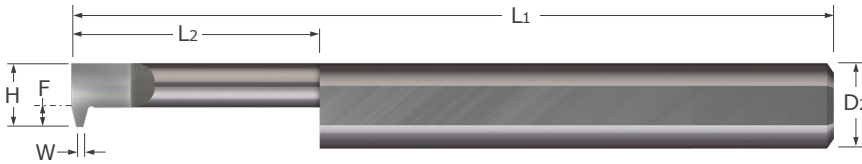

- Designed for cutting pitch-specific stub ACME threads
- Polished split face for improved edge retention and chip evacuation while reducing galling
- Split face geometry provides optimal edge strength
- Lockdown flat automatically locates tool on center
- AlTiN coated option provides added lubricity and increased wear resistance in difficult to machine materials
- Solid carbide ■ CNC ground in the USA

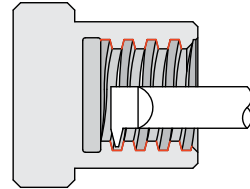

Threads Per Inch	Head Width	Minimum Bore Diameter*	Maximum Bore Depth	Point Offset	Projection	Flat	Centerline Offset	Shank Diameter	Overall Length	Uncoated		AlTiN Coated	
										Tool #	Price	Tool #	Price
TPI	H		L2	Y	P	W	F	D2 (h6)	L1				
			$^{+.050}_{-.000}$ "			$^{+.000}_{-.005}$ "							
16	.200	.222	.400	.024	.045	.024	.0750	.2500	2.5	SAT-400-16	38.30	SAT-400-16X	44.35
16	.200	.222	.600	.024	.045	.024	.0750	.2500	2.5	SAT-600-16	38.30	SAT-600-16X	44.35
16	.200	.222	.750	.024	.045	.024	.0750	.2500	2.5	SAT-750-16	38.30	SAT-750-16X	44.35
16	.200	.222	1.000	.024	.045	.024	.0750	.2500	2.5	SAT-1000-16	38.30	SAT-1000-16X	44.35
14	.235	.257	.500	.045	.070	.028	.0788	.3125	2.5	SAT-500-14	47.40	SAT-500-14X	54.65
14	.235	.257	.750	.045	.070	.028	.0788	.3125	2.5	SAT-750-14	47.40	SAT-750-14X	54.65
14	.235	.257	1.000	.045	.070	.028	.0788	.3125	2.5	SAT-1000-14	47.40	SAT-1000-14X	54.65
14	.235	.257	1.750	.045	.070	.028	.0788	.3125	2.5	SAT-1750-14	47.40	SAT-1750-14X	54.65
12	.360	.382	.500	.051	.085	.033	.1725	.3750	2.5	SAT-500-12	62.45	SAT-500-12X	71.05
12	.360	.382	.750	.051	.085	.033	.1725	.3750	2.5	SAT-750-12	62.45	SAT-750-12X	71.05
12	.360	.382	1.000	.051	.085	.033	.1725	.3750	2.5	SAT-1000-12	62.45	SAT-1000-12X	71.05
12	.360	.382	1.250	.051	.085	.033	.1725	.3750	2.5	SAT-1250-12	62.45	SAT-1250-12X	71.05
12	.360	.382	1.800	.051	.085	.033	.1725	.3750	2.5	SAT-1800-12	62.45	SAT-1800-12X	71.05
10	.490	.512	.750	.062	.120	.037	.2400	.5000	3.0	SAT-750-10	87.60	SAT-750-10X	99.30
10	.490	.512	1.500	.062	.120	.037	.2400	.5000	3.0	SAT-1500-10	87.60	SAT-1500-10X	99.30
10	.490	.512	2.000	.062	.120	.037	.2400	.5000	3.0	SAT-2000-10	87.60	SAT-2000-10X	99.30
9	.490	.512	2.000	.052	.120	.042	.2400	.5000	3.0	SAT-2000-9	87.60	SAT-2000-9X	99.30
8	.490	.512	.750	.068	.120	.048	.2400	.5000	3.0	SAT-750-8	87.60	SAT-750-8X	99.30
8	.490	.512	1.500	.068	.120	.048	.2400	.5000	3.0	SAT-1500-8	87.60	SAT-1500-8X	99.30
8	.490	.512	2.000	.068	.120	.048	.2400	.5000	3.0	SAT-2000-8	87.60	SAT-2000-8X	99.30
7	.490	.512	.750	.059	.120	.055	.2400	.5000	3.0	SAT-750-7	87.60		
7	.490	.512	2.000	.059	.120	.055	.2400	.5000	3.0	SAT-2000-7	87.60	SAT-2000-7X	99.30
6	.490	.512	2.000	.076	.120	.065	.2400	.5000	3.0	SAT-2000-6	87.60	SAT-2000-6X	99.30
5	.490	.512	.750	.083	.120	.079	.2400	.5000	3.0	SAT-750-5	87.60	SAT-750-5X	99.30
5	.490	.512	1.500	.083	.120	.079	.2400	.5000	3.0	SAT-1500-5	87.60	SAT-1500-5X	99.30
5	.490	.512	2.000	.083	.120	.079	.2400	.5000	3.0	SAT-2000-5	87.60	SAT-2000-5X	99.30

*Suggested Minimum Bore Diameter to accommodate chip evacuation and retract clearance in static (not live) applications.

Standard – Threading Tools

IDRT

UN Threads – Right Hand – Brazed

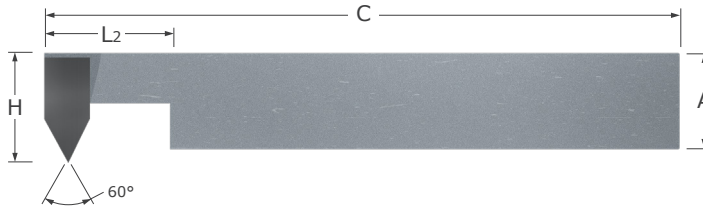

- Designed for threading multiple thread pitches (ANSI, UN and Metric 60°)
- Designed for single point threading where a square shank tool is required in .450" bores and larger
- Sharp corner profile
- Lockdown flat automatically locates tool on center
- Solid carbide tipped with zinc coated steel shank for durability and corrosion resistance
- CNC ground in the USA

Head Width	Maximum Bore Depth	Square Shank	Overall Length	Brazed Style	
				Tool #	Price
H	$L_2 \begin{smallmatrix} +.050'' \\ -.000'' \end{smallmatrix}$	$A \begin{smallmatrix} +.0000'' \\ -.0030'' \end{smallmatrix}$	C		
.450	.615	.3750	2.50	IDRT-60	55.40
.450	1.115	.3750	2.50	IDRT-61	55.40
.575	.875	.5000	3.52	IDRT-80	55.90
.575	1.395	.5000	3.52	IDRT-81	51.45

Standard – Threading Tools

Standard – Threading Tools

IDLT

UN Threads – Left Hand – Brazed

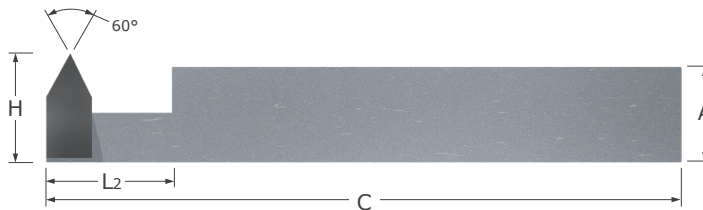

- Designed for threading multiple thread pitches (ANSI, UN, and Metric 60°) in a left hand threading application
- Designed for single point threading where a square shank tool is required in .450" bores and larger
- Sharp corner profile
- Lockdown flat automatically locates tool on center
- Solid carbide tipped with zinc coated steel shank for durability and corrosion resistance ■ CNC ground in the USA

Head Width	Maximum Bore Depth	Square Shank	Overall Length	Brazed Style	
				Tool #	Price
H	$L_2 \begin{smallmatrix} +.050'' \\ -.000'' \end{smallmatrix}$	$A \begin{smallmatrix} +.0000'' \\ -.0030'' \end{smallmatrix}$	C		
.450	.615	.3750	2.50	IDLT-60	55.40
.450	1.115	.3750	2.50	IDLT-61	55.40
.575	.875	.5000	3.52	IDLT-80	55.90
.575	1.395	.5000	3.52	IDLT-81	55.90

LTR

Standard – Threading Tools

Thread Relief Tools

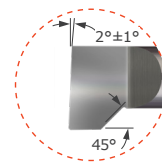
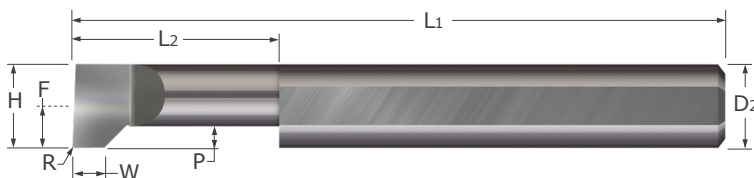

- Designed for plunging thread relief at the bottom of a thread
- Polished split face for improved edge retention and chip evacuation while reducing galling
- Split face geometry provides optimal edge strength
- Lockdown flat automatically locates tool on center
- AlTiN coated option provides added lubricity and increased wear resistance in difficult to machine materials
- Solid carbide ■ CNC ground in the USA

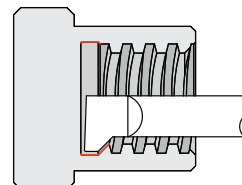

Head Width	Minimum Bore Diameter*	Maximum Bore Depth	Flat	Radius	Projection	Centerline Offset	Shank Diameter	Overall Length	Uncoated		AlTiN Coated	
									Tool #	Price	Tool #	Price
H	L2	W	R	P	F	D2 (h6)	L1	Tool #	Price	Tool #	Price	
.094	.104	.250	.049	.002	.040	.0315	.1250	1.5	LTR-094-4	27.90	LTR-094-4X	31.80
.094	.104	.375	.049	.002	.040	.0315	.1250	1.5	LTR-094-6	27.90	LTR-094-6X	31.80
.125	.139	.375	.063	.002	.040	.0625	.1250	1.5	LTR-125-6	27.90	LTR-125-6X	31.80
.125	.139	.500	.063	.002	.040	.0625	.1250	1.5	LTR-125-8	27.90	LTR-125-8X	31.80

H	L2	W	R	P	F	D2 (h6)	L1	Tool #	Price	Tool #	Price	
.156	.174	.375	.063	.005	.040	.0625	.1875	2.0	LTR-156-6	32.05	LTR-156-6X	36.50
.156	.174	.500	.063	.005	.040	.0625	.1875	2.0	LTR-156-8	32.05	LTR-156-8X	36.50
.187	.205	.375	.078	.005	.040	.0938	.1875	2.0	LTR-187-6	32.05	LTR-187-6X	36.50
.187	.205	.500	.078	.005	.040	.0938	.1875	2.0	LTR-187-8	32.05	LTR-187-8X	36.50
.187	.205	.750	.078	.005	.040	.0938	.1875	2.0	LTR-187-12	32.05	LTR-187-12X	36.50
.187	.205	1.000	.078	.005	.040	.0938	.1875	2.0	LTR-187-16	32.05	LTR-187-16X	36.50
.250	.272	.500	.094	.005	.050	.1250	.2500	2.5	LTR-250-8	38.30	LTR-250-8X	44.35
.250	.272	.750	.094	.005	.050	.1250	.2500	2.5	LTR-250-12	38.30	LTR-250-12X	44.35
.250	.272	1.000	.094	.005	.050	.1250	.2500	2.5	LTR-250-16	38.30	LTR-250-16X	44.35
.250	.272	1.250	.094	.005	.050	.1250	.2500	2.5	LTR-250-20	38.30	LTR-250-20X	44.35
.312	.334	.750	.094	.005	.075	.1563	.3125	2.5	LTR-312-12	47.95	LTR-312-12X	55.20
.312	.334	1.250	.094	.005	.075	.1563	.3125	2.5	LTR-312-20	47.95	LTR-312-20X	55.20
.375	.397	.750	.125	.005	.100	.1875	.3750	2.5	LTR-375-12	63.15	LTR-375-12X	71.75
.375	.397	1.250	.125	.005	.100	.1875	.3750	2.5	LTR-375-20	63.15	LTR-375-20X	71.75
.500	.522	1.000	.156	.010	.125	.2500	.5000	3.0	LTR-500-16	89.40	LTR-500-16X	101.10
.500	.522	1.500	.156	.010	.125	.2500	.5000	3.0	LTR-500-24	89.40	LTR-500-24X	101.10

*Suggested Minimum Bore Diameter to accommodate chip evacuation and retract clearance in static (not live) applications.

Indexable - Boring Bars

Boring - Coolant Through - Right Hand

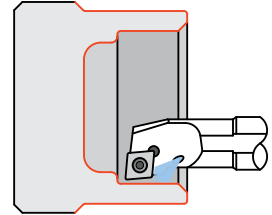
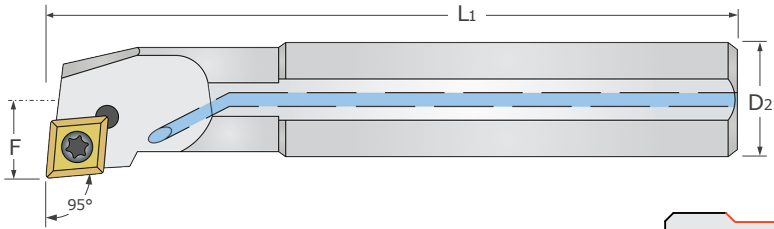

- Coolant through boring bar for right hand boring and facing with 5° approach (lead) angle
- Made from precision ground heat treated steel
- Coolant through design for improved chip removal
- Insert not included

Minimum Bore Diameter*	Centerline Offset	Shank Diameter	Overall Length	Insert Part Number	Holder Nomenclature	Tool Holder	
						Tool #	Price
	F	D ₂	L ₁				
.330	.177	.2500	3.1	50-1100	A04F SCLCR 2	20-0821	75.35
.380	.197	.3125	3.9	50-1100	A05H SCLCR 2	20-0823	77.30
.490	.275	.3750	4.5	50-1100	A06J SCLCR 2	20-0825	80.70
.630	.354	.5000	4.9	50-1100	A08K SCLCR 2	20-0827	84.10
.630	.354	.5000	4.9	50-1105	A08K SCLCR 3	20-0850	87.45
.775	.433	.6250	5.9	50-1100	A10M SCLCR 2	20-0829	89.85
.775	.433	.6250	5.9	50-1105	A10M SCLCR 3	20-0852	93.20
.925	.511	.7500	7.1	50-1105	A12Q SCLCR 3	20-0854	100.90

*Suggested Minimum Bore Diameter to accommodate .015" insert radius, chip evacuation and retract clearance in static (not live) applications.

Indexable - Boring

See pg 318 for indexable insert accessories

See pgs 312-317 for tool set options

Indexable – Boring Bars

Boring – Coolant Through – Left Hand

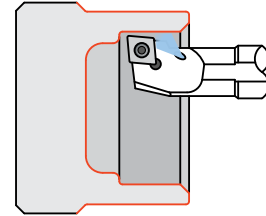
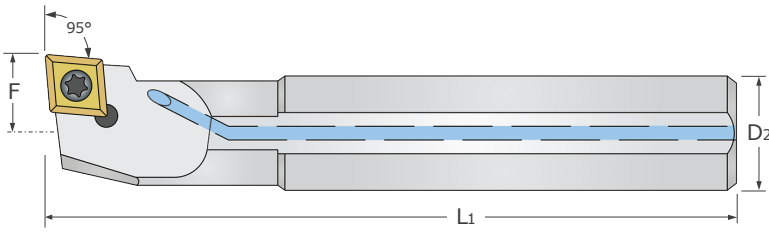

- Coolant through boring bar for left hand boring & facing with 5° approach (lead) angle
- Made from precision ground heat treated steel
- Coolant through design for improved chip removal
- Insert not included

Minimum Bore Diameter*	Centerline Offset	Shank Diameter	Overall Length	Insert Part Number	Holder Nomenclature	Tool Holder	
	F					D ₂	L ₁
.330	.177	.2500	3.1	50-1100	A04F SCLCL 2	20-0822	75.35
.380	.197	.3125	3.9	50-1100	A05H SCLCL 2	20-0824	77.30
.490	.275	.3750	4.5	50-1100	A06J SCLCL 2	20-0826	80.70
.630	.354	.5000	4.9	50-1100	A08K SCLCL 2	20-0828	84.10
.630	.354	.5000	4.9	50-1105	A08K SCLCL 3	20-0851	87.45
.775	.433	.6250	5.9	50-1100	A10M SCLCL 2	20-0830	89.85
.775	.433	.6250	5.9	50-1105	A10M SCLCL 3	20-0853	93.20
.925	.511	.7500	7.1	50-1105	A12Q SCLCL 3	20-0855	100.90

*Suggested Minimum Bore Diameter to accommodate .015" insert radius, chip evacuation and retract clearance in static (not live) applications.

See pg 318 for indexable insert accessories

See pgs 312-317 for tool set options

Indexable – Boring Bars

Facing – Coolant Through – Right Hand

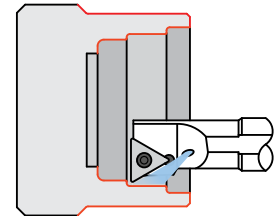
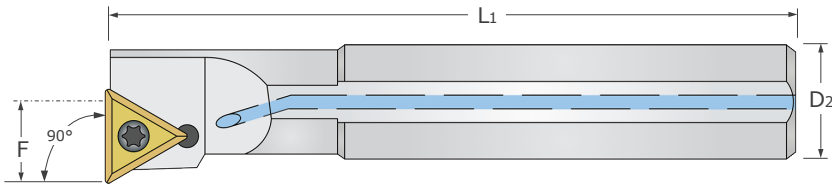

- Coolant through boring bar for left hand boring and facing with 0° approach (lead) angle, which allows for deeper roughing passes
- Made from precision ground heat treated steel
- Coolant through design for improved chip removal
- Insert not included

Minimum Bore Diameter*	Centerline Offset	Shank Diameter	Overall Length	Insert Part Number	Holder Nomenclature	Tool Holder	
	F					D ₂	L ₁
.490	.275	.3750	4.3	50-1300	A06J STFCL 2	20-1031	78.75
.633	.354	.5000	4.9	50-1300	A08K STFCL 2	20-1033	83.35
.775	.433	.6250	5.9	50-1300	A10M STFCL 2	20-1035	84.40

*Suggested Minimum Bore Diameter to accommodate .015" insert radius, chip evacuation and retract clearance in static (not live) applications.

Indexable – Boring

Indexable – Boring Bars

Facing – Coolant Through – Left Hand

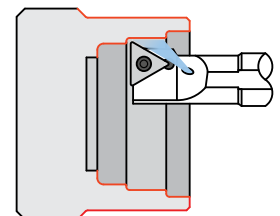
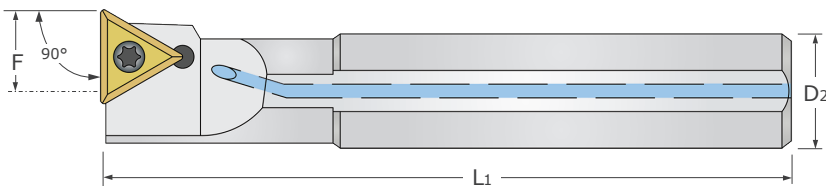

- Coolant through boring bar for left hand boring and facing with 0° approach (lead) angle, which allows for deeper roughing passes
- Made from precision ground heat treated steel
- Coolant through design for improved chip removal
- Insert not included

Minimum Bore Diameter*	Centerline Offset	Shank Diameter	Overall Length	Insert Part Number	Holder Nomenclature	Tool Holder	
	F					D ₂	L ₁
.490	.275	.3750	4.3	50-1300	A06J STFCL 2	20-1032	78.75
.633	.354	.5000	4.9	50-1300	A08K STFCL 2	20-1034	83.35
.775	.433	.6250	5.9	50-1300	A10M STFCL 2	20-1036	84.40

*Suggested Minimum Bore Diameter to accommodate .015" insert radius, chip evacuation and retract clearance in static (not live) applications.

See pg 318 for indexable insert accessories

See pgs 312-317 for tool set options

Indexable - Boring Bars

Profiling - Coolant Through - Right Hand

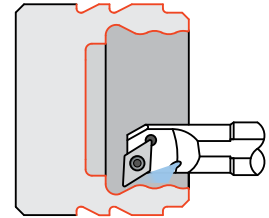
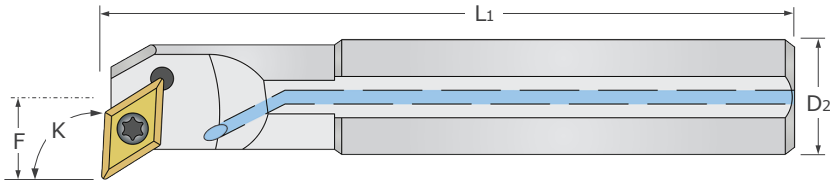

- Coolant through boring bar for right hand boring, facing, and profiling
- Made from precision ground heat treated steel
- Coolant through design for improved chip removal
- Insert not included

Minimum Bore Diameter*	Centerline Offset	K Angle	Shank Diameter	Overall Length	Insert Part Number	Holder Nomenclature	Tool Holder	
							Tool #	Price
	F	K	D ₂	L ₁				
.563	.197	107.5°	.3125	3.9	50-1200	A05H SDQCR 2	20-0901	75.70
.622	.275	93°	.3750	4.5	50-1200	A06J SDUCR 2	20-0931	78.75
.732	.354	93°	.5000	4.9	50-1200	A08K SDUCR 2	20-0933	83.35
.868	.433	93°	.6250	5.9	50-1200	A10M SDUCR 2	20-0935	84.40

*Suggested Minimum Bore Diameter to accommodate .015" insert radius, chip evacuation and retract clearance in static (not live) applications.

Indexable - Boring Bars

Profiling - Coolant Through - Left Hand

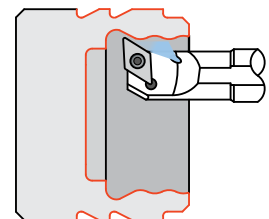
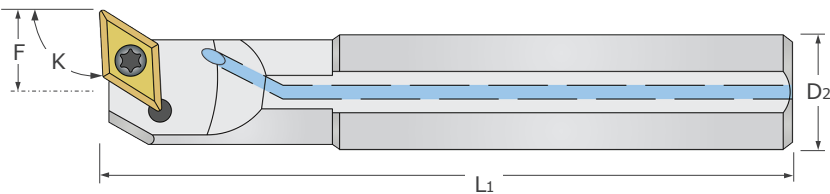

- Coolant through boring bar for left hand boring, facing, and profiling
- Made from precision ground heat treated steel
- Coolant through design for improved chip removal
- Insert not included

Minimum Bore Diameter*	Centerline Offset	K Angle	Shank Diameter	Overall Length	Insert Part Number	Holder Nomenclature	Tool Holder	
							Tool #	Price
	F	K	D ₂	L ₁				
.563	.197	107.5°	.3125	3.9	50-1200	A05H SDQCL 2	20-0902	75.70
.622	.275	93°	.3750	4.5	50-1200	A06J SDUCL 2	20-0932	78.75
.732	.354	93°	.5000	4.9	50-1200	A08K SDUCL 2	20-0934	83.35
.868	.433	93°	.6250	5.9	50-1200	A10M SDUCL 2	20-0936	84.40

*Suggested Minimum Bore Diameter to accommodate .015" insert radius, chip evacuation and retract clearance in static (not live) applications.

See pg 318 for indexable insert accessories

See pgs 312-317 for tool set options

Indexable - Tool Holders

Chamfering & Turning - Style SCMCN

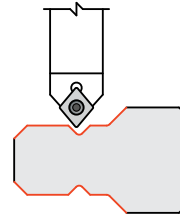
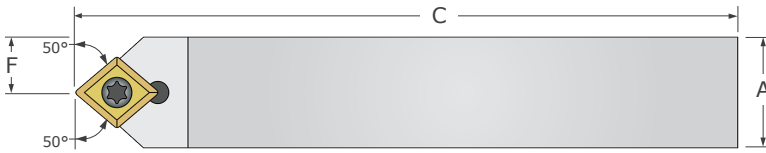

- Turning, profiling, and chamfering insertable holder utilizing 50° right hand and 50° left hand cutting edges
- Made from precision ground heat treated steel
- Insert not included

Locating Offset	Square Shank	Overall Length	Insert Part Number	Holder Nomenclature	Tool Holder	
					Tool #	Price
F	A	C				
.157	.2500	2.4	50-1100	SCMCN 0404 D2	10-3311	41.10
.157	.3125	2.4	50-1100	SCMCN 0505 D2	10-3312	44.55
.189	.3750	2.8	50-1100	SCMCN 0606 E2	10-3313	50.10
.250	.5000	3.2	50-1100	SCMCN 0808 F2	10-3314	54.80
.315	.6250	3.9	50-1100	SCMCN 1010 H2	10-3315	60.75

Indexable - Tool Holders

Chamfering & Turning - Style SCSCR

Indexable - Tool Holders

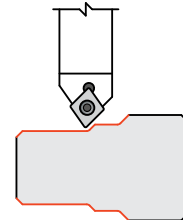
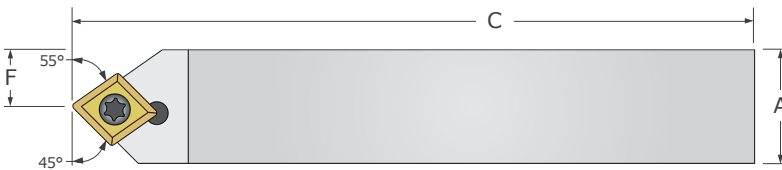

- Chamfering, profiling, and turning holder utilizing the 45° right hand or 55° left hand cutting edges
- Made from precision ground heat treated steel
- Insert not included

Locating Offset	Square Shank	Overall Length	Insert Part Number	Holder Nomenclature	Tool Holder	
					Tool #	Price
F	A	C				
.157	.2500	2.4	50-1100	SCSCR 0404 D2	10-3351	41.10
.157	.3125	2.4	50-1100	SCSCR 0505 D2	10-3353	44.55
.189	.3750	2.8	50-1100	SCSCR 0606 E2	10-3355	50.10
.250	.5000	3.2	50-1100	SCSCR 0808 F2	10-3357	54.80
.315	.6250	3.9	50-1100	SCSCR 1010 H2	10-3359	60.75
.390	.7500	4.9	50-1100	SCSCR 1212 J3	10-3365	71.35

See pg 318 for indexable insert accessories

See pgs 312-317 for tool set options

Indexable – Tool Holders

Facing & Turning – Axial – Right Hand – Style SCKCR

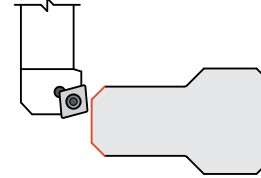
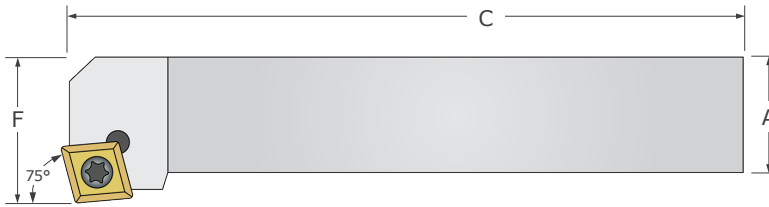

- 75° facing and chamfering holder utilizing 100° unused left hand cutting edge of insert
- Made from precision ground heat treated steel
- Insert not included

Locating Offset	Square Shank	Overall Length	Insert Part Number	Holder Nomenclature	Tool Holder	
					Tool #	Price
F	A	C				
.394	.2500	2.4	50-1100	SCKCR 0404 D2	10-3211	41.10
.394	.3125	2.4	50-1100	SCKCR 0505 D2	10-3212	44.55
.472	.3750	2.8	50-1100	SCKCR 0606 E2	10-3213	50.10
.630	.5000	3.2	50-1100	SCKCR 0808 F2	10-3215	54.80
.787	.6250	3.9	50-1100	SCKCR 1010 H2	10-3217	60.75

See pg 318 for indexable insert accessories

See pgs 312-317 for tool set options

Indexable – Tool Holders

Facing & Turning – Radial – Right Hand – Style SCLCR

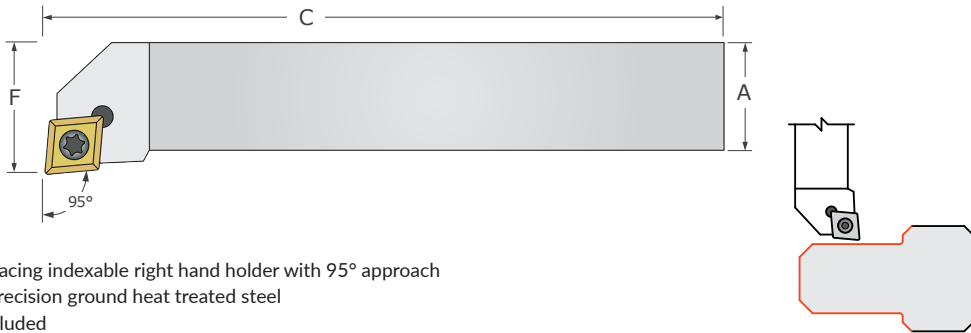

- Turning and facing indexable right hand holder with 95° approach
- Made from precision ground heat treated steel
- Insert not included

Locating Offset	Square Shank	Overall Length	Insert Part Number	Holder Nomenclature	Tool Holder	
					Tool #	Price
F	A	C				
.394	.2500	2.4	50-1100	SCLCR 0404 D2	10-3231	41.10
.394	.3125	2.4	50-1100	SCLCR 0404 D2	10-3233	44.55
.472	.3750	2.8	50-1100	SCLCR 0606 E2	10-3235	50.10
.628	.5000	3.2	50-1100	SCLCR 0808 F2	10-3237	54.80
.787	.6250	3.9	50-1100	SCLCR 1010 H2	10-3241	60.75
1.000	.7500	4.9	50-1105	SCLCR 1212 J3	10-3251	71.35

Indexable – Tool Holders

Indexable – Tool Holders

Facing & Turning – Radial – Left Hand – Style SCLCL

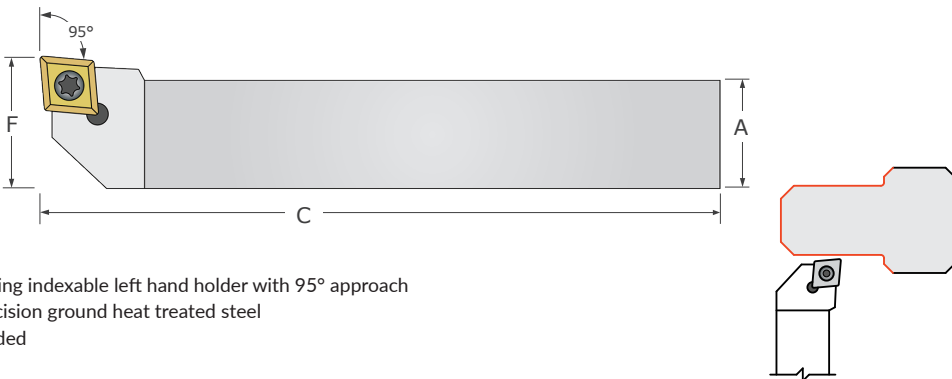

- Turning and facing indexable left hand holder with 95° approach
- Made from precision ground heat treated steel
- Insert not included

Locating Offset	Square Shank	Overall Length	Insert Part Number	Holder Nomenclature	Tool Holder	
					Tool #	Price
F	A	C				
.394	.2500	2.4	50-1100	SCLCL 0404 D2	10-3232	41.10
.394	.3125	2.4	50-1100	SCLCL 0505 D2	10-3234	44.55
.472	.3750	2.8	50-1100	SCLCL 0606 E2	10-3236	50.10
.600	.5000	3.2	50-1100	SCLCL 0808 F2	10-3238	54.80
.787	.6250	3.9	50-1100	SCLCL 1010 H2	10-3242	60.75
1.000	.7500	4.9	50-1105	SCLCL 1212 J3	10-3252	71.35

See pg 318 for indexable insert accessories

See pgs 312-317 for tool set options

Indexable – Tool Holders

Facing & Turning – Radial – Right Hand – Style SDJCR

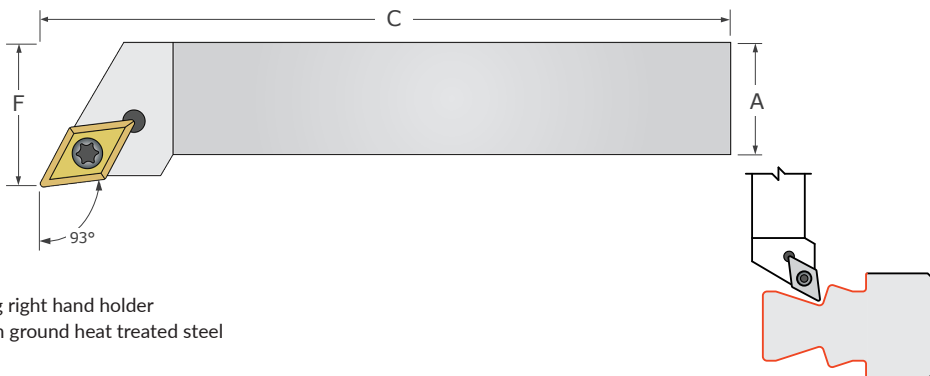

- Turning and profiling right hand holder
- Made from precision ground heat treated steel
- Insert not included

Locating Offset	Square Shank	Overall Length	Insert Part Number	Holder Nomenclature	Tool Holder	
					Tool #	Price
F	A	C				
.394	.3125	3.9	50-1200	SDJCR 0505 H2	10-3641	50.10
.472	.3750	3.9	50-1200	SDJCR 0606 H2	10-3651	58.65
.629	.5000	3.9	50-1200	SDJCR 0808H2	10-3653	61.75
.787	.6250	3.9	50-1200	SDJCR 1010 H2	10-3615	68.50

Indexable – Tool Holders

Facing & Turning – Radial – Left Hand – Style SDJCL

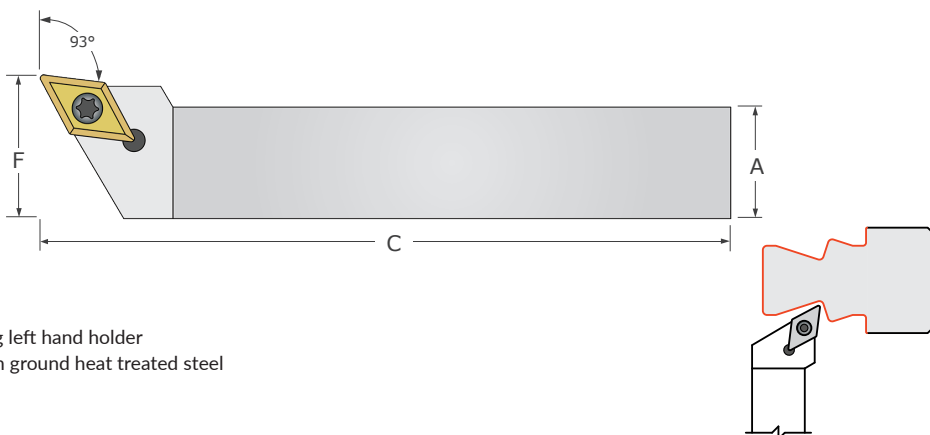

- Turning and profiling left hand holder
- Made from precision ground heat treated steel
- Insert not included

Locating Offset	Square Shank	Overall Length	Insert Part Number	Holder Nomenclature	Tool Holder	
					Tool #	Price
F	A	C				
.394	.3125	3.9	50-1200	SDJCL 0505 H2	10-3642	50.10
.472	.3750	3.9	50-1200	SDJCL 0606 H2	10-3652	58.65
.629	.7500	3.9	50-1200	SDJCL 0808H2	10-3654	61.75
.787	.6250	3.9	50-1200	SDJCL 1010 H2	10-3616	68.50

See pg 318 for indexable insert accessories

See pgs 312-317 for tool set options

Indexable - Tool Holders

Facing & Turning – Radial – Right Hand – Style SCBCR

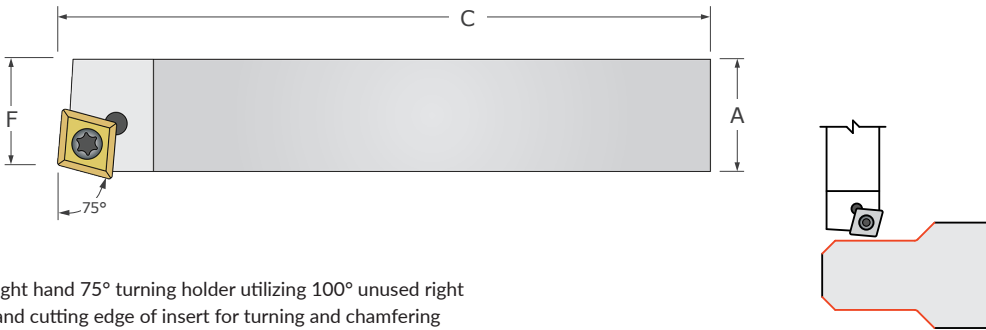

- Right hand 75° turning holder utilizing 100° unused right hand cutting edge of insert for turning and chamfering
- Made from precision ground heat treated steel
- Insert not included

Locating Offset	Square Shank	Overall Length	Insert Part Number	Holder Nomenclature	Tool Holder	
					Tool #	Price
F	A	C				
.267	.2500	2.4	50-1100	SCBCR 0404 D2	10-3151	41.10
.267	.3125	2.4	50-1100	SCBCR 0505 D2	10-3153	44.55
.330	.3750	2.8	50-1100	SCBCR 0606 E2	10-3155	50.10
.460	.5000	3.2	50-1100	SCBCR 0808 F2	10-3157	54.80
.574	.6250	3.9	50-1100	SCBCR 1010 H2	10-3159	60.75

Indexable - Tool Holders

Indexable - Tool Holders

Profiling – Style SDNCN

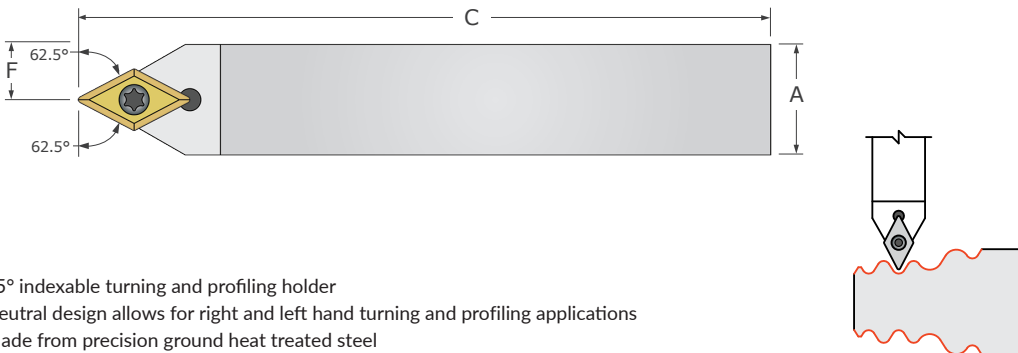

- 55° indexable turning and profiling holder
- Neutral design allows for right and left hand turning and profiling applications
- Made from precision ground heat treated steel
- Insert not included

Locating Offset	Square Shank	Overall Length	Insert Part Number	Holder Nomenclature	Tool Holder	
					Tool #	Price
F	A	C				
.157	.3125	3.9	50-1200	SDNCN 0505 H2	10-3761	50.10
.189	.3750	3.9	50-1200	SDNCN 0606 H2	10-3762	58.65
.250	.5000	3.9	50-1200	SDNCN 0808 H2	10-3763	61.75
.313	.6250	3.9	50-1200	SDNCN 1010 H2	10-3764	68.50

See pg 318 for indexable insert accessories

See pgs 312-317 for tool set options

BT

Brazed - Box Turning Tools

BT Style

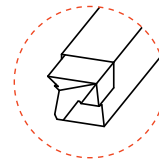
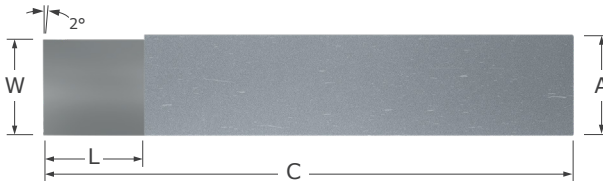

- Designed to be used for outside diameter (OD) turning with roller box turning attachments in automatic screw machines and turret lathes
- Ground to provide high metal removal rates improved finish and concentricity, when used in conjunction with a properly adjusted roller box turning attachment
- Solid carbide tipped with zinc coated hardened steel shank for durability and corrosion resistance
- Available in industry standard fractional shank sizes ■ Ground in the USA

Width	Length	Square Shank	Overall Length	BT Style	
$W \begin{smallmatrix} +.040'' \\ -.000'' \end{smallmatrix}$	L	$A \begin{smallmatrix} +.0000'' \\ -.0100'' \end{smallmatrix}$	C	Tool #	Price
.200	.185	.2500	1.50	BT-4	32.90
.263	.185	.3125	1.75	BT-5	38.65
.325	.310	.3750	2.00	BT-6	34.85
.388	.310	.4375	2.25	BT-7	56.25
.450	.375	.5000	2.50	BT-8	38.00
.513	.375	.5625	2.75	BT-9	67.75
.575	.500	.6250	3.00	BT-10	58.85

BTL

Brazed - Box Turning Tools

BTL Style

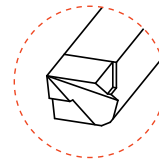
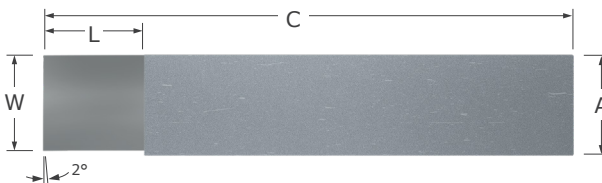

- Designed to be used for left hand outside diameter (OD) turning with roller box turning attachments in automatic screw machines and turret lathes
- Ground to provide high metal removal rates, improved finish, and concentricity when used in conjunction with a properly adjusted roller box turning attachment
- Solid carbide tipped with zinc coated hardened steel shank for durability and corrosion resistance
- Available in industry standard fractional shank sizes ■ Ground in the USA

Width	Length	Square Shank	Overall Length	BTL Style	
$W \begin{smallmatrix} +.040'' \\ -.000'' \end{smallmatrix}$	L	$A \begin{smallmatrix} +.0000'' \\ -.0100'' \end{smallmatrix}$	C	Tool #	Price
.200	.185	.2500	1.50	BTL-4	54.10
.263	.185	.3125	1.75	BTL-5	54.20
.325	.310	.3750	2.00	BTL-6	56.40
.388	.310	.4375	2.25	BTL-7	56.90
.450	.375	.5000	2.50	BTL-8	56.45
.513	.375	.5625	2.75	BTL-9	68.00
.575	.500	.6250	3.00	BTL-10	72.25

Brazed

Brazed – Forming Tools

AR

AR Style

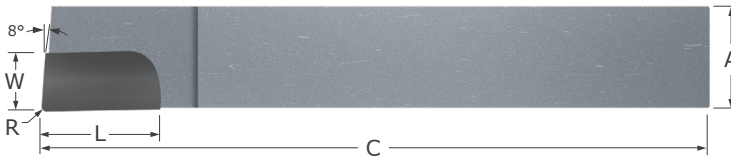

- Designed for right hand turning and facing in lathe applications
- Ground with side rake to provide a positive cutting action and better chip evacuation
- Corner radius profile
- Solid carbide tipped with zinc coated steel shank for durability and corrosion resistance
- Available in industry standard fractional shank sizes ■ Ground in the USA

Radius	Width	Length	Square Shank	Overall Length	AR Style	
R	W	L	A $^{+.0000}$ $_{-.0050}$ "	C	Tool #	Price
.015	.170	.250	.2500	2.00	AR-4	11.40
.015	.233	.312	.3125	2.25	AR-5	11.15
.015	.240	.500	.3750	2.50	AR-6	11.90
.015	.233	.500	.4375	3.00	AR-7	13.35
.015	.235	.625	.5000	3.50	AR-8	13.85
.015	.360	.750	.6250	4.00	AR-10	23.00
.015	.420	.812	.7500	4.50	AR-12	32.10

Brazed – Forming Tools

AL

AL Style

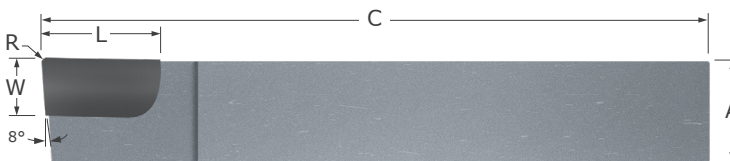

- Designed for left hand turning and facing on the outside diameter (OD) in lathe applications
- Ground with side rake to provide a positive cutting action and better chip evacuation
- Corner radius profile
- Solid carbide tipped with zinc coated steel shank for durability and corrosion resistance
- Available in industry standard fractional shank sizes ■ Ground in the USA

Radius	Width	Length	Square Shank	Overall Length	AL Style	
R	W	L	A $^{+.0000}$ $_{-.0050}$ "	C	Tool #	Price
.015	.170	.250	.2500	2.00	AL-4	11.35
.015	.233	.312	.3125	2.25	AL-5	11.15
.015	.240	.500	.3750	2.50	AL-6	11.90
.015	.233	.500	.4375	3.00	AL-7	13.45
.015	.235	.625	.5000	3.50	AL-8	13.90
.015	.360	.750	.6250	4.00	AL-10	23.00
.015	.420	.812	.7500	4.50	AL-12	32.10

Brazed

BR

Brazed – Forming Tools

BR Style

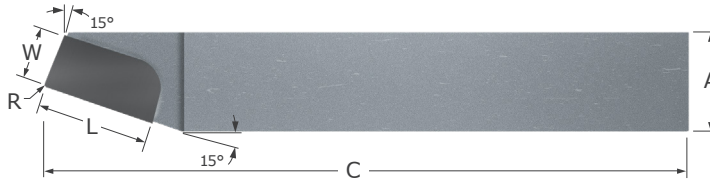

- Designed with a 15° side cutting edge angle for right hand turning in lathe applications
- Ground with side rake to provide a positive cutting action and better chip evacuation
- Side cutting edge angle allow for higher feed rates
- Corner radius profile
- Solid carbide tipped with zinc coated steel shank for durability and corrosion resistance
- Available in industry standard fractional shank sizes
- Ground in the USA

Radius	Width	Length	Square Shank	Overall Length	BR Style	
R	W	L	A $\begin{smallmatrix} +.0000'' \\ -.0050'' \end{smallmatrix}$	C	Tool #	Price
.015	.250	.500	.3750	2.5	BR-6	13.35
.015	.250	.500	.4375	3.0	BR-7	16.35
.015	.250	.625	.5000	3.5	BR-8	13.60
.015	.375	.750	.6250	4.0	BR-10	24.25
.015	.438	.813	.7500	4.5	BR-12	33.55

BL

Brazed – Forming Tools

BL Style

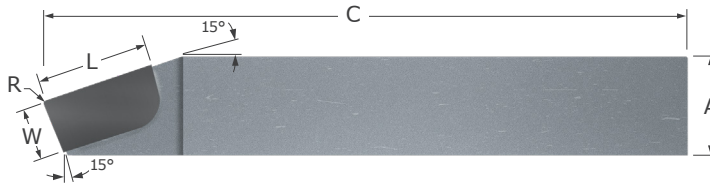

- Designed with a 15° side cutting edge angle for right hand turning in lathe applications
- Ground with side rake to provide a positive cutting action and better chip evacuation
- Side cutting edge angle allow for higher feed rates
- Corner radius profile
- Solid carbide tipped with zinc coated steel shank for durability and corrosion resistance
- Available in industry standard fractional shank sizes
- Ground in the USA

Radius	Width	Length	Square Shank	Overall Length	BL Style	
R	W	L	A $\begin{smallmatrix} +.0000'' \\ -.0050'' \end{smallmatrix}$	C	Tool #	Price
.015	.250	.500	.3750	2.5	BL-6	13.45
.015	.250	.500	.4375	3.0	BL-7	16.60
.015	.250	.625	.5000	3.5	BL-8	15.55
.015	.375	.750	.6250	4.0	BL-10	24.25
.015	.438	.813	.7500	4.5	BL-12	38.50

Brazed

Brazed – Forming Tools

C

C Style

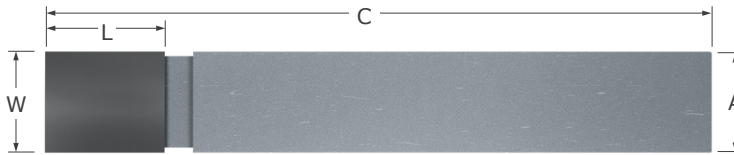

- Neutral design allows for right and left hand modifications
- First choice when modifying or making specials
- Solid carbide tipped with zinc coated steel shank for durability and corrosion resistance
- Available in industry standard fractional shank sizes
- Ground in the USA

Width	Length	Square Shank	Overall Length	C Style	
W	L	A $\begin{smallmatrix} +.0000'' \\ -.0050'' \end{smallmatrix}$	C	Tool #	Price
.235	.250	.2500	6.00	C-250	30.50
.235	.250	.2500	2.00	C-4	11.45
.281	.375	.2812	6.00	C-281	46.25
.312	.375	.3125	6.00	C-312	25.60
.313	.375	.3125	2.25	C-5	12.95
.375	.500	.3750	2.50	C-6	13.20
.375	.500	.3750	6.00	C-375	21.30
.437	.500	.4375	6.00	C-437	38.45
.438	.500	.4375	3.00	C-7	19.05
.500	.500	.5000	3.50	C-8	16.35
.500	.500	.5000	6.00	C-500	26.10
.625	.625	.6250	4.00	C-10	28.45
.750	.750	.7500	4.00	C-750	55.80
.750	.750	.7500	4.50	C-12	34.15

Brazed

Brazed – Forming Tools

CRT

CRT Style – Full Radius (Concave)

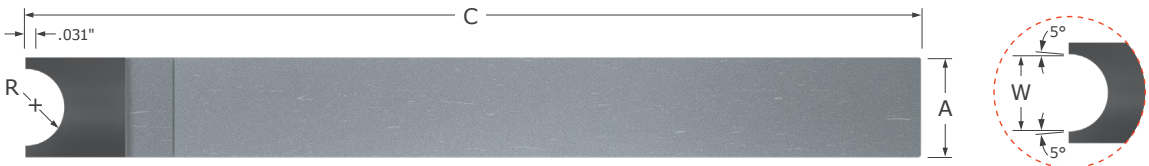

- Designed for forming a convex radius on the outside diameter (OD) of a part
- Solid carbide tipped with zinc coated steel shank for durability and corrosion resistance
- Available in industry standard fractional shank sizes
- Ground in the USA

Radius	Width	Square Shank	Overall Length	CRT Style	
R $\begin{smallmatrix} +.0005'' \\ -.0005'' \end{smallmatrix}$	W $\begin{smallmatrix} +.004'' \\ -.004'' \end{smallmatrix}$	A $\begin{smallmatrix} +.0000'' \\ -.0050'' \end{smallmatrix}$	C	Tool #	Price
.0312	.067	.3750	2.5	CRT-1	50.15
.0625	.129	.3750	2.5	CRT-2	50.15
.0938	.192	.3750	2.5	CRT-3	50.15
.1250	.254	.5000	3.5	CRT-4	57.60
.1875	.379	.5000	3.5	CRT-6	62.05
.2500	.504	.7500	4.5	CRT-8	90.50

Brazed - Forming Tools

D Style

D

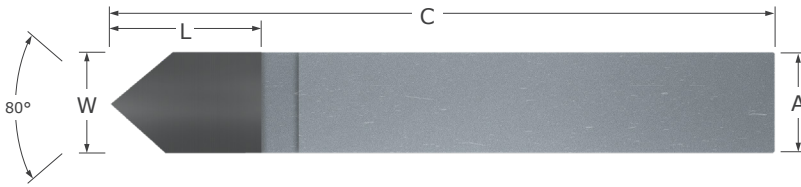

- Designed as a multi-functional tool for a manual lathe
- Solid carbide tipped with zinc coated steel shank for durability and corrosion resistance
- Available in industry standard fractional shank sizes
- Ground in the USA

Width	Length	Square Shank	Overall Length	D Style	
W	L	A $\begin{smallmatrix} +.0000" \\ -.0030" \end{smallmatrix}$	C	Tool #	Price
.2500	.313	.2500	2.00	D-4	10.85
.3125	.375	.3125	2.25	D-5	13.95
.3750	.500	.3750	2.50	D-6	12.00
.4375	.500	.4375	3.00	D-7	16.75
.5000	.500	.5000	3.50	D-8	13.10
.6250	.625	.6250	4.00	D-10	23.35
.7500	.725	.7500	4.50	D-12	31.10

Brazed - Forming Tools

90° Radius Convex - Right Hand

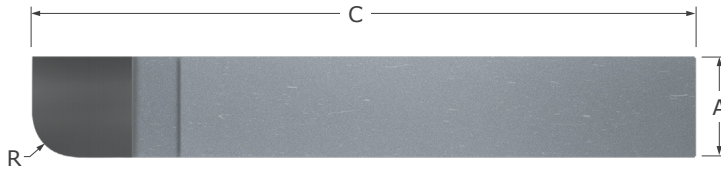

- Designed for forming a concave radius
- Solid carbide tipped with zinc coated steel shank for durability and corrosion resistance
- Available in industry standard fractional shank sizes
- Ground in the USA

Radius	Square Shank	Overall Length	Brazed	
			Tool #	Price
$R \begin{matrix} +.0005'' \\ -.0005'' \end{matrix}$	$A \begin{matrix} +.0000'' \\ -.0050'' \end{matrix}$	C		
.0312	.3750	2.5	RXD-1	49.45
.0625	.3750	2.5	RXD-2	49.45
.0938	.3750	2.5	RXD-3	49.45
.1250	.3750	2.5	RXD-4	49.45
.1562	.3750	2.5	RXD-5	49.45
.1875	.3750	2.5	RXD-6	49.45
.2188	.3750	2.5	RXD-7	49.45
.2500	.3750	2.5	RXD-8	49.45
.2812	.5000	3.5	RXD-9	53.85
.3438	.5000	3.5	RXD-11	53.85
.3750	.5000	3.5	RXD-12	53.85
.4062	.7500	4.5	RXD-13	60.70
.4375	.7500	4.5	RXD-14	60.70
.4688	.7500	4.5	RXD-15	60.70
.5000	.7500	4.5	RXD-16	60.70

Brazed

RXL

Brazed - Forming Tools
90° Radius Convex - Left Hand

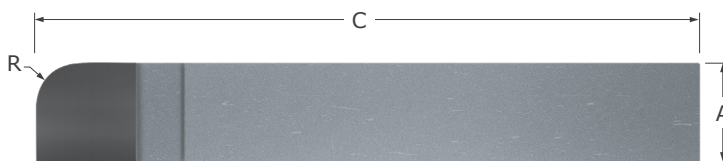

- Designed for forming a concave radius
- Solid carbide tipped with zinc coated steel shank for durability and corrosion resistance
- Available in industry standard fractional shank sizes
- Ground in the USA

Radius	Square Shank	Overall Length	Brazed	
			Tool #	Price
$R \begin{smallmatrix} +.0005'' \\ -.0005'' \end{smallmatrix}$	$A \begin{smallmatrix} +.0000'' \\ -.0050'' \end{smallmatrix}$	C		
.0312	.3750	2.5	RXL-1	49.45
.0625	.3750	2.5	RXL-2	49.45
.0938	.3750	2.5	RXL-3	49.45
.1562	.3750	2.5	RXL-5	49.45
.1875	.3750	2.5	RXL-6	49.45
.2188	.3750	2.5	RXL-7	49.45
.2500	.3750	2.5	RXL-8	49.45
.2812	.5000	3.5	RXL-9	53.85
.3125	.5000	3.5	RXL-10	61.80
.3438	.5000	3.5	RXL-11	61.80
.3750	.5000	3.5	RXL-12	61.80
.4062	.7500	4.5	RXL-13	60.70
.4375	.7500	4.5	RXL-14	60.70
.4688	.7500	4.5	RXL-15	60.70
.5000	.7500	4.5	RXL-16	60.70

Brazed

Brazed – Forming Tools

90° Radius Concave – Right Hand

RAD

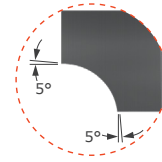
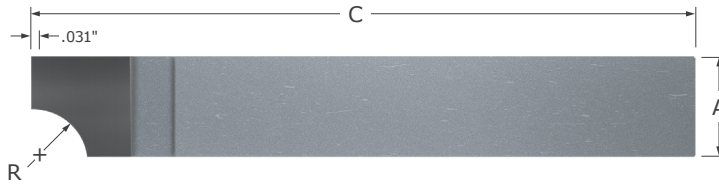

- Right hand tool designed for forming a convex radius
- Tangential 5° blend angles aid in providing a burr-free transition
- Solid carbide tipped with zinc coated steel shank for durability and corrosion resistance
- Available in industry standard fractional shank sizes
- Ground in the USA

Radius	Square Shank	Overall Length	Brazed	
			Tool #	Price
$R \begin{matrix} +.0005'' \\ -.0005'' \end{matrix}$	$A \begin{matrix} +.0000'' \\ -.0050'' \end{matrix}$	C		
.0312	.3750	2.5	RAD-1	49.45
.0625	.3750	2.5	RAD-2	49.45
.0938	.3750	2.5	RAD-3	49.45
.1250	.3750	2.5	RAD-4	49.45
.1562	.3750	2.5	RAD-5	49.45
.1875	.3750	2.5	RAD-6	49.45
.2188	.3750	2.5	RAD-7	49.45
.2500	.3750	2.5	RAD-8	49.45
.2812	.5000	3.5	RAD-9	53.85
.3125	.5000	3.5	RAD-10	53.85
.3438	.5000	3.5	RAD-11	53.85
.3750	.5000	3.5	RAD-12	53.85
.4062	.7500	4.5	RAD-13	60.70
.4375	.7500	4.5	RAD-14	60.70
.4688	.7500	4.5	RAD-15	60.70
.5000	.7500	4.5	RAD-16	60.70

Brazed

See pg 311 for tool set options

RAL

Brazed - Forming Tools

90° Radius Concave - Left Hand



- Left hand tool designed for forming a convex radius
- Tangential 5° blend angles
- Solid carbide tipped with zinc coated steel shank for durability and corrosion resistance
- Available in industry standard fractional shank sizes
- Ground in the USA

Radius	Square Shank	Overall Length	Brazed	
			Tool #	Price
$R \begin{matrix} +.0005'' \\ -.0005'' \end{matrix}$	$A \begin{matrix} +.0000'' \\ -.0050'' \end{matrix}$	C		
.0312	.3750	2.5	RAL-1	49.45
.0625	.3750	2.5	RAL-2	49.45
.0938	.3750	2.5	RAL-3	49.45
.1250	.3750	2.5	RAL-4	49.45
.1562	.3750	2.5	RAL-5	49.45
.1875	.3750	2.5	RAL-6	49.45
.2188	.3750	2.5	RAL-7	49.45
.2500	.3750	2.5	RAL-8	49.45
.2812	.5000	3.5	RAL-9	53.85
.3125	.5000	3.5	RAL-10	53.85
.3438	.5000	3.5	RAL-11	53.85
.3750	.5000	3.5	RAL-12	53.85
.4062	.7500	4.5	RAL-13	60.70
.4375	.7500	4.5	RAL-14	60.70
.4688	.7500	4.5	RAL-15	60.70
.5000	.7500	4.5	RAL-16	60.70

Brazed

Brazed - Forming Tools

Round Shank

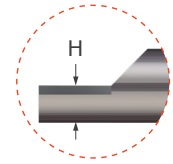
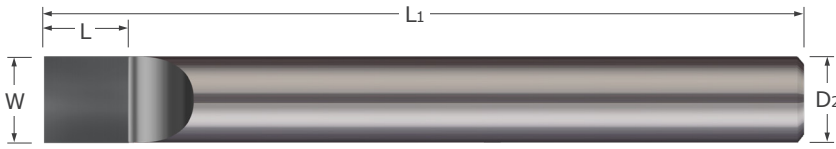

- Carbide tipped design allows for modification into a round shank special
- Carbide is mounted .031" above centerline to allow for grinding
- Neutral design allows for right and left hand modifications
- Solid carbide tipped with zinc coated steel shank for durability and corrosion resistance
- Available in industry standard fractional shank sizes ■ Ground in the USA

Width	Length	Split Height	Shank Diameter	Overall Length	Brazed	
W $\begin{matrix} +.0000" \\ -.0050" \end{matrix}$	L $\begin{matrix} +.031" \\ -.031" \end{matrix}$	H $\begin{matrix} +.000" \\ -.010" \end{matrix}$	D2 $\begin{matrix} +.0000" \\ -.0030" \end{matrix}$	L1	Tool #	Price
.2500	.253	.156	.2500	2.5	TRG-4	27.75
.3125	.375	.187	.3125	3.0	TRG-5	29.60
.3750	.500	.219	.3750	3.5	TRG-6	32.10
.4375	.500	.250	.4375	4.0	TRG-7	34.80
.5000	.500	.281	.5000	5.0	TRG-8	34.80
.6250	.625	.344	.6250	6.0	TRG-10	43.70

Brazed - Grooving Tools

FRT Style - Full Radius (Convex)

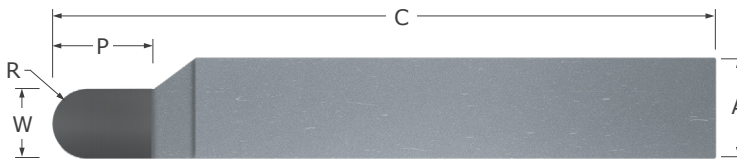

- Designed for generating a concave radius on the outside diameter (OD) of a part
- Available in industry standard shank sizes
- Solid carbide tipped with zinc coated steel shank for durability and corrosion resistance
- Ground in the USA

Radius	Width	Projection	Square Shank	Overall Length	Brazed	
R $\begin{matrix} +.0005" \\ -.0005" \end{matrix}$	W $\begin{matrix} +.001" \\ -.001" \end{matrix}$	P $\begin{matrix} +.015" \\ -.015" \end{matrix}$	A $\begin{matrix} +.0000" \\ -.0050" \end{matrix}$	C	Tool #	Price
.0312	.063	1.000	.3750	2.5	FRT-1	52.55
R $\begin{matrix} +.0005" \\ -.0005" \end{matrix}$	W $\begin{matrix} +.001" \\ -.001" \end{matrix}$	P $\begin{matrix} +.031" \\ -.031" \end{matrix}$	A $\begin{matrix} +.0000" \\ -.0050" \end{matrix}$	C	Tool #	Price
.0625	.125	.375	.3750	2.5	FRT-2	52.55
.0938	.188	.375	.3750	2.5	FRT-3	52.55
.1250	.250	.375	.3750	2.5	FRT-4	52.55
.1563	.313	.375	.3750	2.5	FRT-5	52.55
.1875	.375	.500	.5000	3.5	FRT-6	65.00
.2500	.500	.500	.5000	3.5	FRT-8	65.00
.3125	.625	.625	.6250	4.0	FRT-10	86.45
.3750	.750	.750	.7500	4.5	FRT-12	94.80

GR

Brazed - Grooving Tools

GR Style - Square

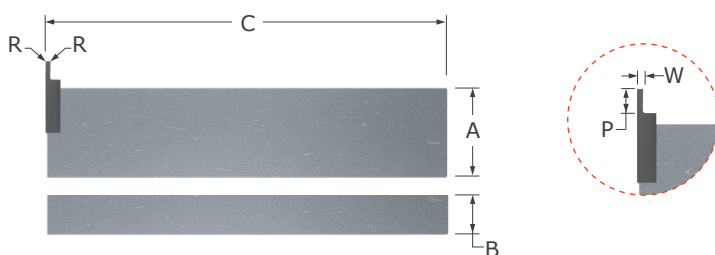

- Designed for plunging outside diameter (OD) grooves when the tool is held parallel to the axis
- Square profile with .003" corner radius for added strength
- Solid carbide tipped with zinc coated steel shank for durability and corrosion resistance
- Available in industry standard fractional shank sizes
- Ground in the USA

Width	Projection	Radius	Shank Width	Shank Height	Overall Length	GR Style	
W $\begin{matrix} +.002'' \\ -.000'' \end{matrix}$	P $\begin{matrix} +.000'' \\ -.030'' \end{matrix}$	R (max)	A $\begin{matrix} +.0000'' \\ -.0050'' \end{matrix}$	B $\begin{matrix} +.0000'' \\ -.0050'' \end{matrix}$	C	Tool #	Price
.012	.030	.003	.7500	.3750	4.0	GR-012002	45.95
.018	.060	.003	.7500	.3750	4.0	GR-018002	45.95
.022	.090	.003	.7500	.3750	4.0	GR-022002	45.95
.028	.090	.003	.7500	.3750	4.0	GR-028002	45.95
.038	.120	.003	.7500	.3750	4.0	GR-038002	45.95
.040	.150	.003	.7500	.3750	4.0	GR-040002	45.95
.046	.150	.003	.7500	.3750	4.0	GR-046002	45.95
.054	.180	.003	.7500	.3750	4.0	GR-054002	45.95
.060	.210	.003	.7500	.3750	4.0	GR-060002	45.95
.072	.240	.003	.7500	.3750	4.0	GR-072002	45.95
.080	.270	.003	.7500	.3750	4.0	GR-080002	45.95
.086	.270	.003	.7500	.3750	4.0	GR-086002	45.95
.090	.300	.003	.7500	.3750	4.0	GR-090002	45.95
.096	.300	.003	.7500	.3750	4.0	GR-096002	45.95
.102	.400	.003	.7500	.3750	4.0	GR-102002	45.95
.114	.400	.003	.7500	.3750	4.0	GR-114002	45.95
.120	.400	.003	.7500	.3750	4.0	GR-120002	45.95
.122	.400	.003	.7500	.3750	4.0	GR-122002	45.95

Brazed



Brazed – Grooving Tools

GR-F

GR Style – Full Radius

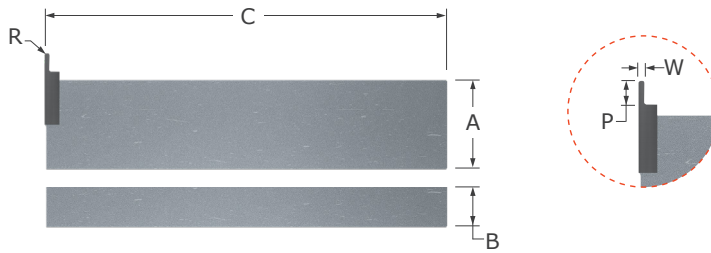

- Designed for plunging full radius outside diameter (OD) grooves when the tool is held parallel to the axis
- Solid carbide tipped with zinc coated steel shank for durability and corrosion resistance
- Available in industry standard fractional shank sizes
- Ground in the USA

Radius	Width	Projection	Shank Width	Shank Height	Overall Length	GR-F Style	
R $\begin{matrix} +.001" \\ -.000" \end{matrix}$	W $\begin{matrix} +.002" \\ -.000" \end{matrix}$	P $\begin{matrix} +.000" \\ -.030" \end{matrix}$	A $\begin{matrix} +.0000" \\ -.0050" \end{matrix}$	B $\begin{matrix} +.0000" \\ -.0050" \end{matrix}$	C	Tool #	Price
.006	.012	.030	.7500	.3750	4.0	GR-012F	47.90
.009	.018	.060	.7500	.3750	4.0	GR-018F	47.90
.011	.022	.090	.7500	.3750	4.0	GR-022F	47.90
.019	.038	.120	.7500	.3750	4.0	GR-038F	47.90
.027	.054	.180	.7500	.3750	4.0	GR-054F	47.90
.030	.060	.210	.7500	.3750	4.0	GR-060F	47.90
.034	.068	.210	.7500	.3750	4.0	GR-068F	47.90
.036	.072	.240	.7500	.3750	4.0	GR-072F	47.90
.040	.080	.270	.7500	.3750	4.0	GR-080F	47.90
.043	.086	.270	.7500	.3750	4.0	GR-086F	47.90
.045	.090	.300	.7500	.3750	4.0	GR-090F	47.90
.048	.096	.300	.7500	.3750	4.0	GR-096F	47.90
.051	.102	.400	.7500	.3750	4.0	GR-102F	47.90
.057	.114	.400	.7500	.3750	4.0	GR-114F	47.90
.060	.120	.400	.7500	.3750	4.0	GR-120F	47.90
.061	.122	.400	.7500	.3750	4.0	GR-122F	47.90

Brazed

GS

Brazed - Grooving Tools

GS Style - Square

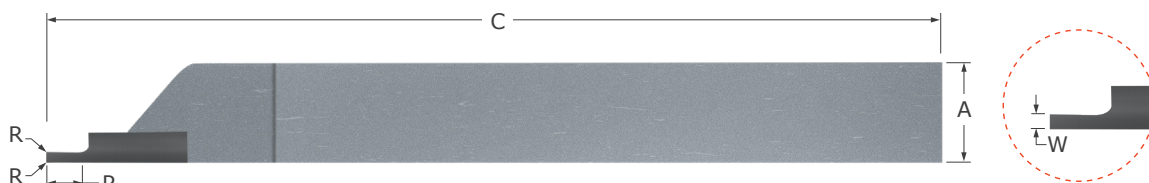

- Designed for plunging grooves when on the outside diameter of a part
- Square profile with .003" corner radius for added strength
- Solid carbide tipped with zinc coated steel shank for durability and corrosion resistance
- Available in industry standard fractional shank sizes
- Ground in the USA

Width	Projection	Radius	Square Shank	Overall Length	GS Style	
					Tool #	Price
W $\begin{matrix} +.002'' \\ -.000'' \end{matrix}$	P $\begin{matrix} +.000'' \\ -.030'' \end{matrix}$	R (max)	A $\begin{matrix} +.0000'' \\ -.0050'' \end{matrix}$	C		
.012	.030	.003	.3750	3.0	GS-012002	37.35
.018	.060	.003	.3750	3.0	GS-018002	37.35
.022	.090	.003	.3750	3.0	GS-022002	37.35
.028	.090	.003	.3750	3.0	GS-028002	37.35
.038	.120	.003	.3750	3.0	GS-038002	37.35
.040	.150	.003	.3750	3.0	GS-040002	37.35
.046	.150	.003	.3750	3.0	GS-046002	37.35
.054	.180	.003	.3750	3.0	GS-054002	37.35
.060	.210	.003	.3750	3.0	GS-060002	37.35
.068	.210	.003	.3750	3.0	GS-068002	37.35
.072	.240	.003	.3750	3.0	GS-072002	37.35
.080	.270	.003	.3750	3.0	GS-080002	37.35
.086	.270	.003	.3750	3.0	GS-086002	37.35
.090	.300	.003	.3750	3.0	GS-090002	37.35
.096	.300	.003	.3750	3.0	GS-096002	37.35
.102	.400	.003	.3750	3.0	GS-102002	37.35
.114	.400	.003	.3750	3.0	GS-114002	37.35
.120	.400	.003	.3750	3.0	GS-120002	37.35
.122	.400	.003	.3750	3.0	GS-122002	37.35

Brazed

Brazed – Grooving Tools

GS-F

GS Style – Full Radius

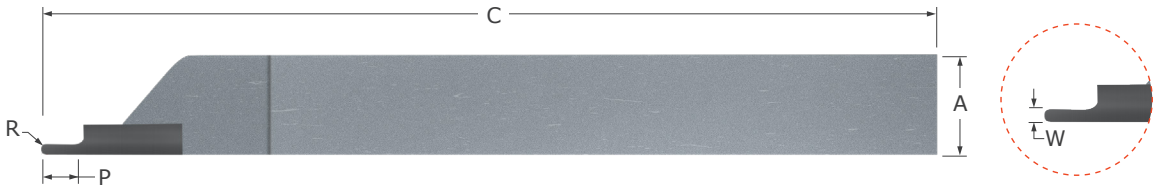

- Designed for generating full radius outside diameter (OD) grooves
- Solid carbide tipped with zinc coated steel shank for durability and corrosion resistance
- Available in industry standard fractional shank sizes
- Ground in the USA

Radius	Width	Projection	Square Shank	Overall Length	GS-F Style	
R $\begin{smallmatrix} +.001" \\ -.000" \end{smallmatrix}$	W $\begin{smallmatrix} +.002" \\ -.000" \end{smallmatrix}$	P $\begin{smallmatrix} +.000" \\ -.030" \end{smallmatrix}$	A $\begin{smallmatrix} +.0000" \\ -.0050" \end{smallmatrix}$	C	Tool #	Price
.006	.012	.030	.3750	3.0	GS-012F	41.25
.009	.018	.060	.3750	3.0	GS-018F	41.25
.011	.022	.090	.3750	3.0	GS-022F	41.25
.014	.028	.090	.3750	3.0	GS-028F	41.25
.019	.038	.120	.3750	3.0	GS-038F	41.25
.020	.040	.150	.3750	3.0	GS-040F	41.25
.023	.046	.150	.3750	3.0	GS-046F	41.25
.027	.054	.180	.3750	3.0	GS-054F	41.25
.030	.060	.210	.3750	3.0	GS-060F	41.25
.034	.068	.210	.3750	3.0	GS-068F	41.25
.036	.072	.240	.3750	3.0	GS-072F	41.25
.040	.080	.270	.3750	3.0	GS-080F	41.25
.045	.090	.300	.3750	3.0	GS-090F	41.25
.048	.096	.300	.3750	3.0	GS-096F	41.25
.051	.102	.400	.3750	3.0	GS-102F	41.25
.060	.120	.400	.3750	3.0	GS-120F	41.25
.061	.122	.400	.3750	3.0	GS-122F	41.25

Brazed

E

Brazed - Threading Tools

E Style

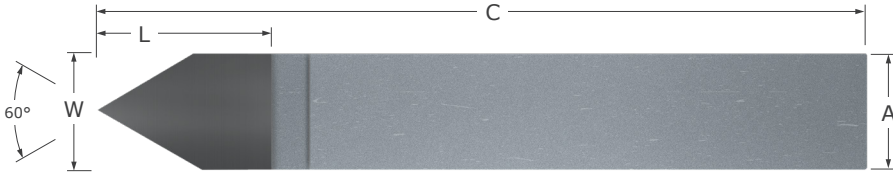

- Designed for outside diameter (OD) general purpose threading
- Neutral design allows for right and left hand threading applications
- Solid carbide tipped with zinc coated steel shank for durability and corrosion resistance
- Available in industry standard fractional shank sizes
- Ground in the USA

Width	Length	Square Shank	Overall Length	E Style	
W	L	A $\begin{smallmatrix} +.0000'' \\ -.0050'' \end{smallmatrix}$	C	Tool #	Price
.3125	.363	.3125	2.25	E-5	15.00
.3750	.568	.3750	2.50	E-6	11.90
.5000	.568	.5000	3.50	E-8	12.90
.6250	.653	.6250	4.00	E-10	23.70
.7500	.778	.7500	4.50	E-12	27.45

ER

Brazed - Threading Tools

ER Style

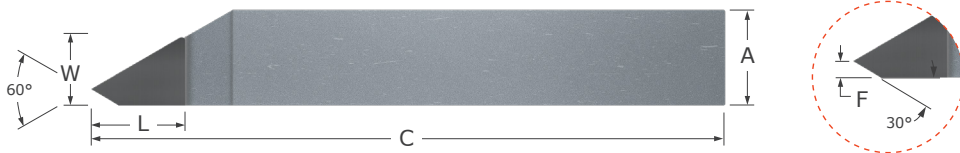

- Designed for right hand threading on the outside diameter (OD), close to a shoulder
- Solid carbide tipped with zinc coated steel shank for durability and corrosion resistance
- Available in industry standard fractional shank sizes
- Ground in the USA

Point Offset	Width	Length	Square Shank	Overall Length	ER Style	
F $\begin{smallmatrix} +.010'' \\ -.010'' \end{smallmatrix}$	W	L	A $\begin{smallmatrix} +.0000'' \\ -.0050'' \end{smallmatrix}$	C	Tool #	Price
.063	.266	.360	.3750	2.50	ER-6	13.60
.063	.270	.360	.3125	2.25	ER-5	14.15
.094	.444	.610	.6250	4.00	ER-10	22.80
.094	.446	.610	.5000	3.50	ER-8	16.20
.125	.558	.750	.7500	4.50	ER-12	35.15

Brazed

Brazed – Threading Tools

EL

EL Style

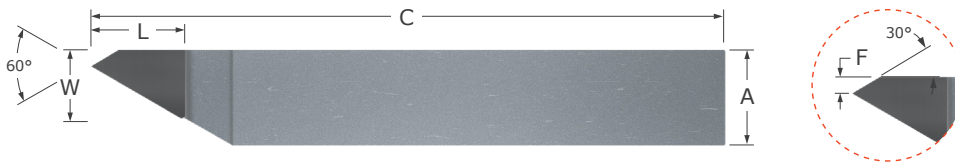

- Designed for left hand threading on the outside diameter (OD), close to a shoulder
- Solid carbide tipped with zinc coated steel shank for durability and corrosion resistance
- Available in industry standard fractional shank sizes
- Ground in the USA

Point Offset	Width	Length	Square Shank	Overall Length	EL Style	
$F \begin{matrix} +.010'' \\ -.010'' \end{matrix}$	W	L	$A \begin{matrix} +.0000'' \\ -.0050'' \end{matrix}$	C	Tool #	Price
.063	.266	.360	.3750	2.50	EL-6	14.30
.063	.270	.360	.3125	2.25	EL-5	14.10
.094	.444	.610	.6250	4.00	EL-10	22.80
.094	.446	.610	.5000	3.50	EL-8	16.95
.125	.558	.750	.7500	4.50	EL-12	38.20

Brazed – Screw Machining Tools

RT / LT

Turning

Brazed

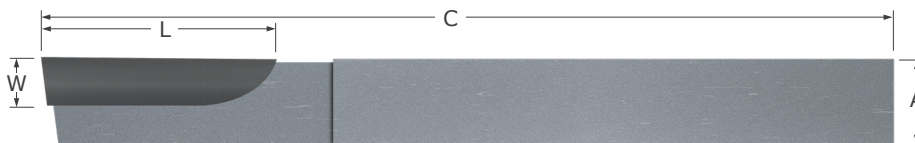

- Designed for general purpose turning; RT for right hand and LT for left hand
- Solid carbide tipped with zinc coated steel shank for durability and corrosion resistance
- Available in industry standard fractional shank sizes
- Ground in the USA

Width	Length	Square Shank	Overall Length	Right Hand		Left Hand	
W	L	$A \begin{matrix} +.0000'' \\ -.0050'' \end{matrix}$	C	Tool #	Price	Tool #	Price
.128	1.075	.2500	6.0	RT-250	46.80	LT-250	44.50
.174	1.200	.2812	6.0	RT-281	46.75	LT-281	41.10
.188	1.200	.3750	6.0	RT-375	18.15	LT-375	36.30
.190	1.200	.3125	6.0	RT-312	35.15	LT-312	17.45
.253	1.345	.5000	6.0	RT-500	23.50	LT-500	29.15
.260	1.345	.4375	6.0	RT-437	42.55	LT-437	37.85
.263	1.345	.6250	4.0	RT-625	42.00	LT-625	40.20
.263	1.345	.7500	4.0	RT-750	45.65	LT-750	44.20

RC / LC

Brazed – Screw Machine Tools

Cut Off

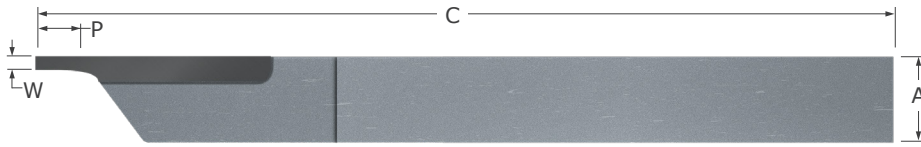

- Designed for cut off applications; RC for right hand and LC for left hand
- Solid carbide tipped with zinc coated steel shank for durability and corrosion resistance
- Available in industry standard fractional shank sizes
- Ground in the USA

Width	Projection	Square Shank	Overall Length	Right Hand		Left Hand	
W ^{+ .000"} _{-.005"}	P (min)	A ^{+ .0000"} _{-.0050"}	C	Tool #	Price	Tool #	Price
.040	.120	.2500	6.0	RC-250040	48.80	LC-250040	48.05
.040	.120	.2812	6.0	RC-281040	49.40	LC-281040	50.35
.040	.120	.3125	6.0	RC-312040	31.90	LC-312040	35.00
.040	.120	.3750	6.0	RC-375040	19.70	LC-375040	36.00
.060	.180	.2500	6.0	RC-250060	49.00	LC-250060	28.25
.060	.180	.2812	6.0	RC-281060	49.40	LC-281060	50.35
.060	.180	.3125	6.0	RC-312060	21.55	LC-312060	22.20
.060	.180	.3750	6.0	RC-375060	18.85	LC-375060	23.70
.060	.180	.4375	6.0	RC-437060	38.10	LC-437060	36.75
.060	.180	.5000	6.0	RC-500060	23.25	LC-500060	23.45
.060	.180	.6250	4.0	RC-625060	30.50	LC-625060	36.35
.060	.180	.7500	4.0	RC-750060	42.75	LC-750060	42.75
.080	.240	.2812	6.0	RC-281080	48.95	LC-281080	35.30
.080	.240	.3125	6.0	RC-312080	29.50	LC-312080	19.65
.080	.240	.3750	6.0	RC-375080	18.85	LC-375080	28.05
.080	.240	.4375	6.0	RC-437080	38.10	LC-437080	40.75
.080	.240	.5000	6.0	RC-500080	23.35	LC-500080	23.55
.080	.240	.6250	4.0	RC-625080	32.35	LC-625080	39.00
.080	.240	.7500	4.0	RC-750080	43.05	LC-750080	45.40
.100	.300	.2812	6.0	RC-281100	49.40	LC-281100	25.60
.100	.300	.3125	6.0	RC-312100	34.35	LC-312100	19.65
.100	.300	.3750	6.0	RC-375100	19.35	LC-375100	25.85
.100	.300	.4375	6.0	RC-437100	38.60	LC-437100	43.45
.100	.300	.5000	6.0	RC-500100	23.35	LC-500100	24.30
.100	.300	.6250	4.0	RC-625100	31.00	LC-625100	32.35
.100	.300	.7500	4.0	RC-750100	36.30	LC-750100	44.85
.120	.360	.3750	6.0	RC-375120	21.45	LC-375120	32.35
.120	.360	.4375	6.0	RC-437120	38.60	LC-437120	37.70
.120	.360	.5000	6.0	RC-500120	23.00	LC-500120	25.10
.125	.375	.6250	4.0	RC-625125	31.00	LC-625125	40.55
.125	.375	.7500	4.0	RC-750125	37.65	LC-750125	45.10
.187	.561	.6250	4.0	RC-625187	40.50	LC-625187	40.50
.187	.561	.7500	4.0	RC-750187	45.40	LC-750187	45.55

Brazed

Brazed – Cut Off Tools

CR Style

CR

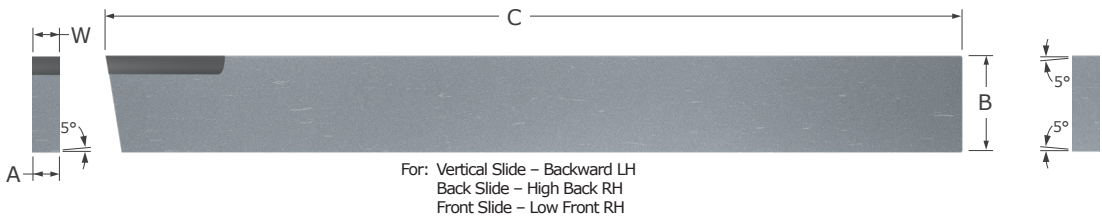

- Right hand cut-off blades for Brown & Sharpe automatic screw machines
- Designed for use in Pratt & Whitney holders and dovetail slot holders
- Carbide tipped with hardened and precision ground steel blade
- Ground in the USA

Width	Shank Width	Shank Height	Overall Length	CR Style	
W $+0.0000''$ $-0.0050''$	A $+0.0000''$ $-0.0050''$	B $+0.0000''$ $-0.0050''$	C	Tool #	Price
.0781	.0580	.5000	4.5	CR-101	75.75
.0938	.0730	.5000	4.5	CR-102	59.45
.0938	.0730	.6875	5.0	CR-104	84.10
.0938	.0730	.8125	6.0	CR-108	94.45
.0938	.0730	1.0000	6.0	CR-113	121.15
.1250	.1050	.5000	4.5	CR-103	57.60
.1250	.1050	.6875	5.0	CR-105	79.70
.1250	.1050	.8125	6.0	CR-109	69.75
.1562	.1360	.6875	5.0	CR-106	84.25
.1562	.1360	.8125	6.0	CR-110	136.35
.1875	.1670	.6875	5.0	CR-107	87.80
.1875	.1670	.8125	6.0	CR-111	137.20

Brazed

CL

Brazed - Cut Off Tools

CL Style

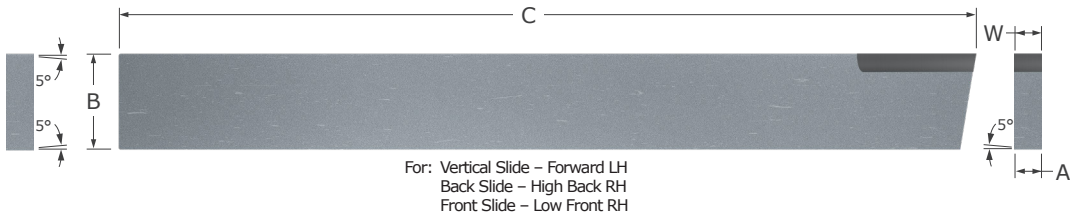

- Left hand cut-off blades for Brown & Sharpe automatic screw machines
- Designed for use in Pratt & Whitney holders and dovetail slot holders
- Carbide tipped with hardened and precision ground steel blade
- Ground in the USA

Width	Shank Width	Shank Height	Overall Length	CL Style	
				Tool #	Price
W $+0.0000"$ $-0.0050"$	A $+0.0000"$ $-0.0050"$	B $+0.0000"$ $-0.0050"$	C		
.0781	.0580	.5000	4.5	CL-101	76.05
.0938	.0730	.5000	4.5	CL-102	76.85
.0938	.0730	.6875	5.0	CL-104	89.55
.0938	.0730	.8125	6.0	CL-108	103.05
.0938	.0730	1.0000	6.0	CL-113	89.05
.1250	.1050	.5000	4.5	CL-103	78.70
.1250	.1050	.6875	5.0	CL-105	97.05
.1250	.1050	.8125	6.0	CL-109	98.25
.1562	.1360	.6875	5.0	CL-106	92.85
.1562	.1360	.8125	6.0	CL-110	129.30
.1875	.1670	.6875	5.0	CL-107	96.40
.1875	.1670	.8125	6.0	CL-111	89.05

Brazed – Cut Off Tools

CT Style

CT

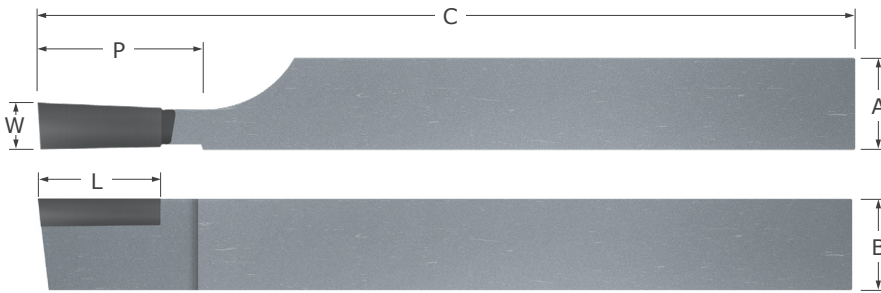

- Designed for cut-off with a 5° front clearance to reduce cut-off burr
- Solid carbide tipped with zinc coated steel shank for durability and corrosion resistance
- Available in industry standard fractional shank sizes
- Ground in the USA

Width	Projection	Length	Shank Width	Shank Height	Overall Length	CT Style	
W $\begin{matrix} +.000" \\ -.005" \end{matrix}$	P $\begin{matrix} +.062" \\ -.000" \end{matrix}$	L	A $\begin{matrix} +.0000" \\ -.0100" \end{matrix}$	B $\begin{matrix} +.0000" \\ -.0100" \end{matrix}$	C	Tool #	Price
.187	.813	.750	.5000	1.0000	5.0	CT-122	30.45
.250	1.000	.750	.5000	1.0000	5.0	CT-121	33.85
.312	1.000	.500	.5000	1.0000	5.0	CT-120	44.15
.375	1.250	.500	.6250	1.2500	5.0	CT-130	45.00
.375	1.250	.625	.7500	1.5000	6.0	CT-140	49.00

Brazed



Build & Send Shopping Carts Directly to Your Distributor or Purchasing Agent

Create Your Micro100 Account Today at Micro100.com

Brazed - Cut Off Tools

T Style - Regular

T

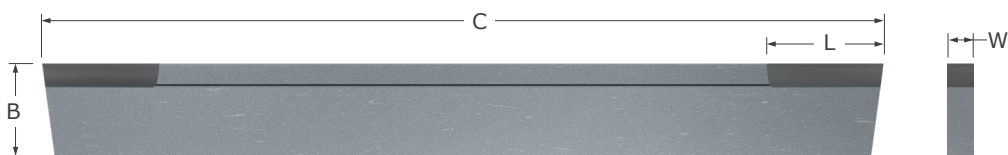

- Double end "T" style cut-off tool that is parallel ground to help achieve a straighter cut
- Tops are hollow ground to help curl the chip to center for better evacuation
- Carbide tipped with hardened and precision ground steel blade
- Ground in the USA

Width	Length	Shank Height	Overall Length	T Style	
W $\begin{matrix} +.001" \\ -.001" \end{matrix}$	L	B	C	Tool #	Price
.062	.750	.5000	4.5	T-100	75.15
.078	.750	.5000	4.5	T-101	76.30
.093	.750	.5000	4.5	T-102	73.05
.093	.750	.6875	5.0	T-104	80.85
.125	.750	.5000	4.5	T-103	72.10
.125	.750	.6875	5.0	T-105	79.90
.125	.750	.7500	5.0	T-108	82.65
.125	.750	.8750	6.0	T-111	90.90
.156	.750	.6875	5.0	T-106	98.05
.156	.750	.7500	5.0	T-109	87.15
.156	.750	.8750	6.0	T-112	90.75
.187	.750	.6875	5.0	T-107	101.25
.187	.750	.7500	5.0	T-110	81.30
.187	.750	.8750	6.0	T-113	106.00
.187	.750	1.1250	6.0	T-116	109.80

Brazed

Brazed - Cut Off Tools

T-V

T Style - V-Groove

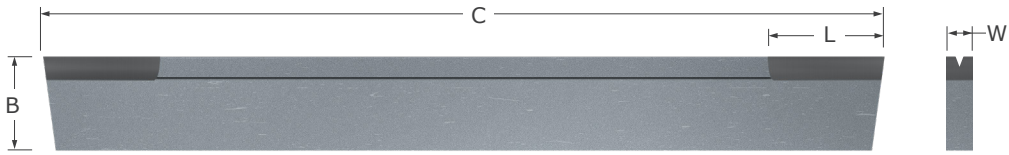

- Double ended "T" style cut-off tool that is parallel ground to help achieve a straighter cut
- Tops are hollow ground to help curl the chip to center for better evacuation
- Additional V-groove ground into the top of the tool forces the chip into a "W" form to pull the chip to center resulting in better surface finish and chip evacuation
- Carbide tipped with hardened and precision ground steel blade
- Ground in the USA

Width	Length	Shank Height	Overall Length	Brazed Style	
				Tool #	Price
W $\begin{matrix} +.001" \\ -.001" \end{matrix}$	L	B	C		
.062	.760	.5000	4.5	T-100-V	78.15
.078	.760	.5000	4.5	T-101-V	79.30
.093	.760	.5000	4.5	T-102-V	76.05
.093	.760	.6875	5.0	T-104-V	83.85
.125	.750	.5000	4.5	T-103-V	75.10
.125	.760	.6875	5.0	T-105-V	82.90
.125	.750	.7500	5.0	T-108-V	85.65
.125	.750	.8750	6.0	T-111-V	93.90
.156	.750	.6875	5.0	T-106-V	101.05
.156	.750	.7500	5.0	T-109-V	90.15
.156	.750	.8750	6.0	T-112-V	93.75
.187	.750	.6875	5.0	T-107-V	104.25
.187	.750	.7500	5.0	T-110-V	84.30
.187	.750	.8750	6.0	T-113-V	109.00
.187	.750	1.1250	6.0	T-116-V	112.80

Brazed



NEW!

HOLEMAKING & THREADING TOOLS

Drills

204

Combined Drill & Countersink

209

Thread Mill Cutters

210

Drills

Spotting & Centering Drill

SPD

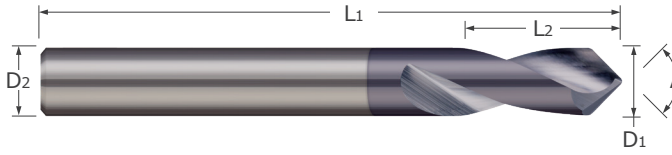

Drills

- Optimized for spotting and chamfering applications
- Available in 82°, 90°, 100°, 120°, and 140° included point angles
- Can be utilized for countersinking and chamfering existing holes
- Maximum drill depth not to exceed included angle
- Solid carbide ■ CNC ground in the USA
- 2 flutes

Included Angle	Drill Diameter	Flute Length	Shank Diameter	Overall Length	Uncoated		AITIN			
					Tool #	Price	Tool #	Price		
A_{-1}^{+1}	$D1_{-0.0005}^{+0.0000}$	$L2_{-0.031}^{+0.031}$	D2 (h6)	L1						
82°	.0937	.279	.1250	1.5	SPD-093-082	24.05	SPD-093-082X	28.25	NEW	
	.1250	.375	.1250	1.5	SPD-125-082	24.05	SPD-125-082X	28.25	NEW	
	.1875	.625	.1875	2.0	SPD-187-082	25.15	SPD-187-082X	29.90	NEW	
	.2500	.750	.2500	2.5	SPD-250-082	25.95	SPD-250-082X	32.25	NEW	
	.3125	.750	.3125	2.5	SPD-312-082	30.25	SPD-312-082X	37.80	NEW	
	.3750	1.000	.3750	2.5	SPD-375-082	38.10	SPD-375-082X	47.05	NEW	
	.5000	1.000	.5000	2.5	SPD-500-082	56.75	SPD-500-082X	69.00	NEW	
	.6250	1.125	.6250	2.5	SPD-625-082	100.40				
	.6250	1.125	.6250	3.0	SPD1-625-082	101.35	SPD1-625-082X	114.95	NEW	
	.7500	1.125	.7500	2.5	SPD-750-082	152.25				
	.7500	1.125	.7500	3.0	SPD1-750-082	153.70	SPD1-750-082X	169.85	NEW	
	90°	.0937	.279	.1250	1.5	SPD-093-090	24.05	SPD-093-090X	28.25	NEW
		.1250	.375	.1250	1.5	SPD-125-090	24.05	SPD-125-090X	28.25	NEW
		.1875	.625	.1875	2.0	SPD-187-090	25.15	SPD-187-090X	29.90	NEW
.2500		.750	.2500	2.5	SPD-250-090	25.95	SPD-250-090X	32.25	NEW	
.3125		.750	.3125	2.5	SPD-312-090	30.25	SPD-312-090X	37.80	NEW	
.3750		1.000	.3750	2.5	SPD-375-090	38.10	SPD-375-090X	47.05	NEW	
.5000		1.000	.5000	2.5	SPD-500-090	56.75	SPD-500-090X	69.00	NEW	
.6250		1.125	.6250	2.5	SPD-625-090	100.40				
.6250		1.125	.6250	3.0	SPD1-625-090	101.35	SPD1-625-090X	114.95	NEW	
.7500		1.125	.7500	2.5	SPD-750-090	152.25				
.7500		1.125	.7500	3.0	SPD1-750-090	153.70	SPD1-750-090X	169.85	NEW	
1.0000		1.250	1.0000	2.5	SPD-001-090	230.80				
1.0000		1.250	1.0000	3.0	SPD1-001-090	233.00			NEW	
100°		.0937	.279	.1250	1.5	SPD-093-100	24.05	SPD-093-100X	28.25	NEW
	.1250	.375	.1250	1.5	SPD-125-100	24.05	SPD-125-100X	28.25	NEW	
	.1875	.625	.1875	2.0	SPD-187-100	25.15	SPD-187-100X	29.90	NEW	
	.2500	.750	.2500	2.5	SPD-250-100	25.95	SPD-250-100X	32.25	NEW	
	.3125	.750	.3125	2.5	SPD-312-100	30.25	SPD-312-100X	37.80	NEW	
	.3750	1.000	.3750	2.5	SPD-375-100	38.10	SPD-375-100X	47.05	NEW	
	.5000	1.000	.5000	2.5	SPD-500-100	56.75	SPD-500-100X	69.00	NEW	
	.6250	1.125	.6250	2.5	SPD-625-100	100.40				
	.6250	1.125	.6250	3.0	SPD1-625-100	101.35	SPD1-625-100X	114.95	NEW	
	.7500	1.125	.7500	2.5	SPD-750-100	152.25				
	.7500	1.125	.7500	3.0	SPD1-750-100	153.70	SPD1-750-100X	169.85	NEW	
	1.0000	1.250	1.0000	2.5	SPD-001-100	230.80				
	1.0000	1.250	1.0000	3.0	SPD1-001-100	233.00			NEW	

SPD

Drills

Spotting & Centering Drill (cont.)

Continued from previous page

	Included Angle	Drill Diameter	Flute Length	Shank Diameter	Overall Length	Uncoated		AlTiN		
						Tool #	Price	Tool #	Price	
	A $\begin{matrix} +1^\circ \\ -1^\circ \end{matrix}$	D1 $\begin{matrix} +.0000'' \\ -.0005'' \end{matrix}$	L2 $\begin{matrix} +.031'' \\ -.031'' \end{matrix}$	D2 (h6)	L1					
NEW	120°	.0937	.279	.1250	1.5	SPD-093-120	24.05	SPD-093-120X	28.25	
NEW		.1250	.375	.1250	1.5	SPD-125-120	24.05	SPD-125-120X	28.25	
		.1875	.625	.1875	2.0	SPD-187-120	25.15	SPD-187-120X	29.90	
NEW		.2500	.750	.2500	2.5	SPD-250-120	25.95	SPD-250-120X	32.25	
NEW		.3125	.750	.3125	2.5	SPD-312-120	30.25	SPD-312-120X	37.80	
NEW		.3750	1.000	.3750	2.5	SPD-375-120	38.10	SPD-375-120X	47.05	
NEW		.5000	1.000	.5000	2.5	SPD-500-120	56.75	SPD-500-120X	69.00	
		.6250	1.125	.6250	2.5	SPD-625-120	100.40			
NEW		.6250	1.125	.6250	3.0	SPD1-625-120	101.35	SPD1-625-120X	114.95	
		.7500	1.125	.7500	2.5	SPD-750-120	152.25			
NEW		.7500	1.125	.7500	3.0	SPD1-750-120	153.70	SPD1-750-120X	169.85	
NEW		140°	.0937	.279	.1250	1.5	SPD-093-140	24.05	SPD-093-140X	28.25
NEW			.1250	.375	.1250	1.5	SPD-125-140	24.05	SPD-125-140X	28.25
NEW			.1875	.625	.1875	2.0	SPD-187-140	25.15	SPD-187-140X	29.90
NEW	.2500		.750	.2500	2.5	SPD-250-140	26.20	SPD-250-140X	32.25	
NEW	.3125		.750	.3125	2.5	SPD-312-140	30.55	SPD-312-140X	37.80	
NEW	.3750		1.000	.3750	2.5	SPD-375-140	38.45	SPD-375-140X	47.05	
NEW	.5000		1.000	.5000	2.5	SPD-500-140	57.30	SPD-500-140X	69.00	

Drills



Find the Perfect Micro 100 Tool For Your Next Job With Product Table Filtering

On Micro100.com



Drills

Spade Drill

SD

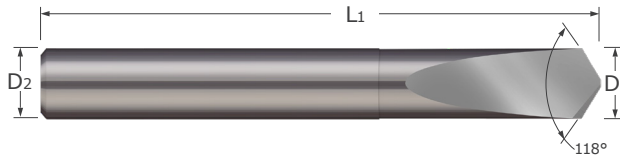

Drills

- Designed for drilling in hardened materials
- Excellent option when requiring holes free of retract marks in non-ferrous materials
- Solid carbide
- CNC ground in the USA

Drill Diameter	Web Thickness	Shank Diameter	Overall Length	Uncoated	
				Tool #	Price
$D_1^{+.0000''}$ $-.0005''$	$+.002''$ $-.002''$	D2 (h6)	L1		
.0312	.010	.0312	1.25	SD-031	14.60
.0625	.012	.0625	1.50	SD-062	15.15
.0937	.016	.0938	1.50	SD-093	15.55
.1250	.020	.1250	1.50	SD-125	17.05
.1562	.025	.1562	2.00	SD-156	18.70
.1875	.028	.1875	2.00	SD-187	21.75
.2188	.030	.2188	2.00	SD-218	25.60
.2500	.035	.2500	2.00	SD-250	29.30
.3125	.040	.3125	2.50	SD-312	40.55
.3750	.046	.3750	2.50	SD-375	48.85
.4375	.050	.4375	2.50	SD-437	56.00
.5000	.060	.5000	2.50	SD-500	68.35

DR

Drills
Miniature

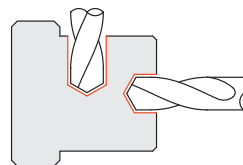
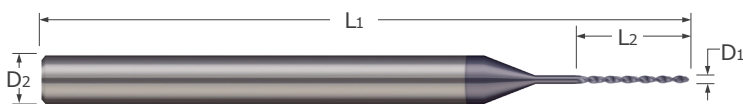

- 1/8" common shank for ease of use in Taper Integrated Holders
- For tools .020" and smaller, there is an intermediate neck diameter as pictured
- 130° drill point
- AlTiN coated option provides added lubricity and increased wear resistance in difficult to machine materials
- Solid carbide ■ CNC Ground in Germany

	Drill Diameter			Flute Length	Shank Diameter	Overall Length	Uncoated		AlTiN Coated	
	inch	wire	metric				Tool #	Price	Tool #	Price
	D1 ^{+ .0000"} ^{**} _{- .0003"}			L2	D2	L1				
NEW	.0039	#102	.100 mm	.026	.1250	1.5	DR01-0039*	26.45		
NEW	.0051	#99	.130 mm	.056	.1250	1.5	DR02-0051	25.80		
NEW	.0059	#97	.150 mm	.066	.1250	1.5	DR02-0059	23.95		
NEW	.0071	#94		.106	.1250	1.5	DR02-0071	21.85		
NEW	.0079	#92	.200 mm	.160	.1250	1.5	DR02-0079	18.30	DR02-0079X	22.50
NEW	.0091	#89		.160	.1250	1.5	DR02-0091	17.85	DR02-0091X	22.05
NEW	.0098		.250 mm	.160	.1250	1.5	DR02-0098	17.85	DR02-0098X	22.05
NEW	.0100	#87		.160	.1250	1.5	DR02-0100	17.85	DR02-0100X	22.05
NEW	.0110	#85		.160	.1250	1.5	DR02-0110	17.85	DR02-0110X	22.05
NEW	.0118		.300 mm	.180	.1250	1.5	DR02-0118	17.85	DR02-0118X	22.05
NEW	.0120	#83		.230	.1250	1.5	DR02-0120	16.15	DR02-0120X	20.35
NEW	.0130	#81		.230	.1250	1.5	DR02-0130	16.15	DR02-0130X	20.35
NEW	.0135	#80		.270	.1250	1.5	DR02-0135	15.75	DR02-0135X	19.95
NEW	.0145	#79		.270	.1250	1.5	DR02-0145	15.75	DR02-0145X	19.95
NEW	.0157		.400 mm	.270	.1250	1.5	DR02-0157	15.75	DR02-0157X	19.95
NEW	.0160	#78		.270	.1250	1.5	DR02-0160	15.75	DR02-0160X	19.95
NEW	.0180	#77		.270	.1250	1.5	DR02-0180	14.65	DR02-0180X	18.85
NEW	.0197		.500 mm	.275	.1250	1.5	DR02-0197	14.65	DR02-0197X	18.85
NEW	.0200	#76		.275	.1250	1.5	DR02-0200	14.65	DR02-0200X	18.85
NEW	.0210	#75		.275	.1250	1.5	DR02-0210	14.65	DR02-0210X	18.85
NEW	.0225	#74		.275	.1250	1.5	DR02-0225	14.65	DR02-0225X	18.85
NEW	.0236		.600 mm	.275	.1250	1.5	DR02-0236	14.65	DR02-0236X	18.85
NEW	.0240	#73		.275	.1250	1.5	DR02-0240	14.65	DR02-0240X	18.85
NEW	.0250	#72		.275	.1250	1.5	DR02-0250	14.65	DR02-0250X	18.85
NEW	.0260	#71		.275	.1250	1.5	DR02-0260	14.65	DR02-0260X	18.85
NEW	.0276		.700 mm	.335	.1250	1.5	DR02-0276	14.65	DR02-0276X	18.85
NEW	.0280	#70		.335	.1250	1.5	DR02-0280	14.65	DR02-0280X	18.85
NEW	.0292	#69		.335	.1250	1.5	DR02-0292	14.65	DR02-0292X	18.85
NEW	.0310	#68		.395	.1250	1.5	DR02-0310	13.70	DR02-0310X	17.90
NEW	.0312			.395	.1250	1.5	DR02-0312	13.70	DR02-0312X	17.90
NEW	.0315		.800 mm	.395	.1250	1.5	DR02-0315	13.70	DR02-0315X	17.90
NEW	.0320	#67		.395	.1250	1.5	DR02-0320	13.70	DR02-0320X	17.90
NEW	.0330	#66		.395	.1250	1.5	DR02-0330	13.70	DR02-0330X	17.90
NEW	.0350	#65		.395	.1250	1.5	DR02-0350	13.70	DR02-0350X	17.90

* Total overhang from shank transition is .250" ** Tolerance for AlTiN coating is +.002"/-.0003" *** Tolerance for AlTiN coating is +.0002"/-.0005

Taper Integrated holders can be found on pg 39

Continued on next page

Drills

DR

Miniature (cont.)

Continued from previous page

Drills

Drill Diameter			Flute Length	Shank Diameter	Overall Length	Uncoated		AlTiN Coated	
inch	wire	metric				Tool #	Price	Tool #	Price
D1 $+0.0001^{**}$ -0.0003^{**}			L2	D2	L1	Tool #	Price	Tool #	Price
.0354		.900 mm	.395	.1250	1.5	DR02-0354	13.70	DR02-0354X	17.90
.0360	#64		.395	.1250	1.5	DR02-0360	13.70	DR02-0360X	17.90
.0370	#63		.395	.1250	1.5	DR02-0370	13.70	DR02-0370X	17.90
.0380	#62		.395	.1250	1.5	DR02-0380	13.70	DR02-0380X	17.90
.0390	#61		.395	.1250	1.5	DR02-0390	13.70	DR02-0390X	17.90
.0394		1.000 mm	.395	.1250	1.5	DR02-0394	13.70	DR02-0394X	17.90
.0400	#60		.395	.1250	1.5	DR02-0400	13.70	DR02-0400X	17.90
.0410	#59		.395	.1250	1.5	DR02-0410	13.70	DR02-0410X	17.90
.0420	#58		.395	.1250	1.5	DR02-0420	13.70	DR02-0420X	17.90
.0430	#57		.395	.1250	1.5	DR02-0430	13.70	DR02-0430X	17.90
.0433		1.100 mm	.395	.1250	1.5	DR02-0433	13.70	DR02-0433X	17.90
.0440			.395	.1250	1.5	DR02-0440	13.70	DR02-0440X	17.90
.0469			.395	.1250	1.5	DR02-0469	13.70	DR02-0469X	17.90
.0472		1.200 mm	.395	.1250	1.5	DR02-0472	13.70	DR02-0472X	17.90
.0500		1.270 mm	.395	.1250	1.5	DR02-0500	13.70	DR02-0500X	17.90
.0512		1.300 mm	.413	.1250	1.5	DR01-0512	13.70	DR01-0512X	17.90
.0520	#55		.413	.1250	1.5	DR01-0520	13.70	DR01-0520X	17.90
.0550	#54		.413	.1250	1.5	DR01-0550	13.70	DR01-0550X	17.90
.0571		1.450 mm	.413	.1250	1.5	DR01-0571	13.70	DR01-0571X	17.90
.0591		1.500 mm	.413	.1250	1.5	DR01-0591	13.70	DR01-0591X	17.90
.0625			.413	.1250	1.5	DR01-0625	13.70	DR01-0625X	17.90

D1 $+0.0001^{***}$ -0.0005^{***}		decimal equiv.	L2	D2	L1	Uncoated		AlTiN Coated	
						Tool #	Price	Tool #	Price
.0635	#52		.413	.1250	1.5	DR01-0635	13.70	DR01-0635X	17.90
.0670	#51		.413	.1250	1.5	DR01-0670	13.70	DR01-0670X	17.90
.0700	#50		.413	.1250	1.5	DR01-0700	13.70	DR01-0700X	17.90
.0730	#49		.413	.1250	1.5	DR01-0730	13.70	DR01-0730X	17.90
.0760	#48		.413	.1250	1.5	DR01-0760	13.70	DR01-0760X	17.90
.0781			.413	.1250	1.5	DR01-0781	13.70	DR01-0781X	17.90
.0787		2.000 mm	.413	.1250	1.5	DR01-0787	13.70	DR01-0787X	17.90
.0810	#46		.413	.1250	1.5	DR01-0810	13.70	DR01-0810X	17.90
.0860	#44		.413	.1250	1.5	DR01-0860	13.70	DR01-0860X	17.90
.0890	#43		.413	.1250	1.5	DR01-0890	13.70	DR01-0890X	17.90
.0938			.413	.1250	1.5	DR01-0938	13.70	DR01-0938X	17.90
.0960	#41		.413	.1250	1.5	DR01-0960	13.70	DR01-0960X	17.90
.0980	#40		.413	.1250	1.5	DR01-0980	13.70	DR01-0980X	17.90
.0995	#39		.413	.1250	1.5	DR01-0995	13.70	DR01-0995X	17.90
.1065	#36		.413	.1250	1.5	DR01-1065	13.70	DR01-1065X	17.90
.1094			.413	.1250	1.5	DR01-1094	13.70	DR01-1094X	17.90
.1110	#34		.413	.1250	1.5	DR01-1110	13.70	DR01-1110X	17.90
.1130	#33		.413	.1250	1.5	DR01-1130	13.70	DR01-1130X	17.90
.1181		3.000 mm	.413	.1250	1.5	DR01-1181	13.70	DR01-1181X	17.90
.1200	#31		.413	.1250	1.5	DR01-1200	13.70	DR01-1200X	17.90
.1250			.413	.1250	1.5	DR01-1250	13.70	DR01-1250X	17.90

* Total overhang from shank transition is .250" ** Tolerance for AlTiN coating is +.002"/-.0003" *** Tolerance for AlTiN coating is +.0002"/-.0005

Taper Integrated holders can be found on pg 39

DR

Drills

Jobber Length Drills

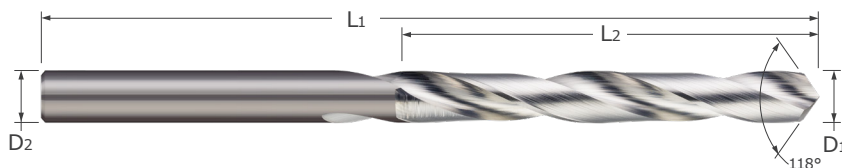

- 118° included point jobber drills can be used for general purpose drilling
- Solid carbide
- CNC ground in the USA

Drill Diameter	Flute Length	Shank Diameter	Overall Length	Uncoated	
				Tool #	Price
$D_1 \begin{smallmatrix} +.0000'' \\ -.0005'' \end{smallmatrix}$	$L_2 \begin{smallmatrix} +.062'' \\ -.062'' \end{smallmatrix}$	$D_2 \text{ (h6)}$	L_1		
.0312	.500	.0312	1.25	DR-031-2	13.10
.0469	.750	.0469	1.50	DR-046-2	17.25
.0625	.750	.0625	1.50	DR-062-2	17.60
.1094	1.250	.1094	2.25	DR-109-2	22.40
.1250	1.250	.1250	2.25	DR-125-2	23.65
.1875	1.625	.1875	2.75	DR-187-2	34.75
.2500	2.000	.2500	3.25	DR-250-2	51.60
.3125	2.375	.3125	3.75	DR-312-2	68.60

DC / DCM

Combined Drill & Countersinks

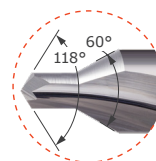
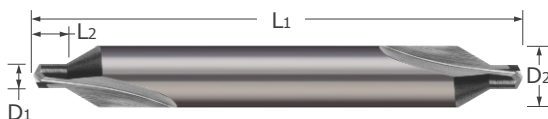

- Designed for predrilling 60° live center holes
- Can be utilized for countersinking and spot drilling
- Double-ended for quicker tool changes
- Solid carbide ■ CNC ground in the USA

Drill Diameter	Drill Length	Shank Diameter	Overall Length	Uncoated	
				Tool #	Price
D_1	L_2	$D_2 \text{ (h6)}$	L_1		
$\begin{smallmatrix} +.0030'' \\ -.0000'' \end{smallmatrix}$					
$\begin{smallmatrix} +.08 \text{ mm} \\ -.00 \text{ mm} \end{smallmatrix}$					
decimal equiv.					
.0250	.0250	.1250	1.500	DC-00	25.45
.0312	.0312	.1250	1.500	DC-01	25.45
0.8 mm	.0320	3.15 mm	35 mm	DCM-008	24.50
1.0 mm	.0390	3.15 mm	35 mm	DCM-010	24.50
.0469	.0469	.1250	1.500	DC-1	25.45
1.25 mm	.0490	3.15 mm	35 mm	DCM-013	24.50
1.6 mm	.0630	4 mm	35.5 mm	DCM-016	35.90
.0781	.0781	.1875	1.875	DC-2	40.05
2.5 mm	.0980	6.3 mm	45 mm	DCM-025	43.05
.1094	.1094	.2500	2.000	DC-3	44.85
3.15 mm	.1240	8 mm	50 mm	DCM-032	57.55
.1250	.1250	.3125	2.125	DC-4	59.95
.1875	.1875	.4375	2.750	DC-5	90.25
.2188	.2188	.5000	3.000	DC-6	115.65



Thread Milling Cutters

Single Form – UN Threads

TM

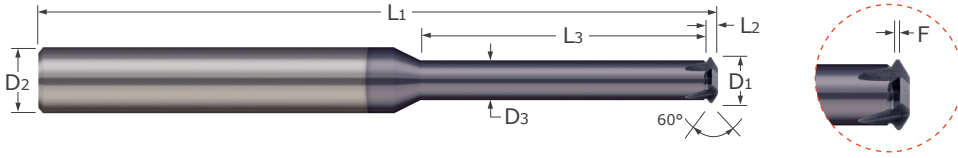

- Mills internal and external 60° UN threads
- Single thread form designed to mill common pitch sizes
- Single form design reduces tool pressure for deep thread milling applications
- Mills right hand and left hand threads
- AlTiN coating option for added lubricity and increased wear resistance in difficult-to-machine materials
- Solid carbide ■ CNC ground in the USA

Thread Milling Cutters

Threads Per Inch	Cutter Diameter	Neck Length	Neck Diameter	Flat	Cutter Width	Flutes	Shank Diameter	Overall Length	Uncoated		AlTiN Coated	
									Tool #	Price	Tool #	Price
TPI	$D_1^{+.0000}_{-.0050}$	$L_3^{+.0150}_{-.0000}$	D_3	$F^{+.0010}_{-.0000}$	L_2		D_2 (h6)	L_1	Tool #	Price	Tool #	Price
56 - 80	.060	.250	.030	SHARP	.017	2	.1250	1.5	TM-060-4	65.30	TM-060-4X	67.45
56 - 80	.060	.375	.030	SHARP	.017	2	.1250	1.5	TM-060-6	65.30	TM-060-6X	67.45
40 - 64	.080	.250	.035	SHARP	.026	2	.1250	1.5	TM-080-4	61.25	TM-080-4X	63.50
40 - 64	.080	.500	.035	SHARP	.026	2	.1250	1.5	TM-080-8	61.25	TM-080-8X	63.50
32 - 64	.100	.375	.050	SHARP	.029	2	.1250	1.5	TM-100-6	52.90	TM-100-6X	55.25
32 - 64	.100	.500	.050	SHARP	.029	2	.1250	1.5	TM-100-8	52.90		
32 - 64	.100	.625	.050	SHARP	.029	2	.1250	2.0	TM-100-10	52.90	TM-100-10X	55.25
32 - 56	.120	.375	.070	.0010	.030	3	.1875	2.0	TM-120-6	62.50	TM-120-6X	65.20
32 - 56	.120	.500	.070	.0010	.030	3	.1875	2.0	TM-120-8	62.50	TM-120-8X	65.20
32 - 56	.120	.625	.070	.0010	.030	3	.1875	2.0	TM-120-10	62.50	TM-120-10X	65.20
24 - 56	.140	.500	.075	.0010	.038	3	.1875	2.0	TM-140-8	62.50	TM-140-8X	65.20
24 - 56	.140	.750	.075	.0010	.038	3	.1875	2.0	TM-140-12	62.50	TM-140-12X	65.20
18 - 56	.180	.500	.090	.0015	.055	4	.2500	2.5	TM-180-8	73.50	TM-180-8X	78.35
18 - 56	.180	.750	.090	.0015	.055	4	.2500	2.5	TM-180-12	73.50	TM-180-12X	78.35
18 - 56	.180	1.000	.090	.0015	.055	4	.2500	2.5	TM-180-16	73.50	TM-180-16X	78.35
16 - 48	.240	1.500	.150	.0015	.055	4	.3125	3.5	TM-250-24	82.05	TM-250-24X	89.90
14 - 48	.250	1.000	.100	.0015	.065	4	.2500	2.5	TM-250-16	73.50	TM-250-16X	78.35
16 - 48	.250	1.125	.150	.0015	.060	4	.2500	2.5	TM-250-18	73.50	TM-250-18X	78.35
14 - 40	.290	1.000	.170	.0020	.071	4	.3750	4.0	TM-290-16	91.25	TM-290-16X	100.60
12 - 32	.360	1.000	.210	.0020	.085	4	.3750	4.0	TM-360-16	91.25	TM-360-16X	100.60
11 - 32	.490	1.000	.300	.0020	.095	5	.5000	4.0	TM-490-16	105.40	TM-490-16X	116.00
11 - 32	.490	1.250	.300	.0020	.095	5	.5000	4.0	TM-490-20	105.40	TM-490-20X	116.00
10 - 32	.600	1.000	.420	.0020	.100	6	.6250	4.0	TM-600-16	131.05	TM-600-16X	143.80
10 - 32	.600	1.250	.420	.0020	.100	6	.6250	4.0	TM-600-20	131.05	TM-600-20X	143.80
5 - 12	.720	1.250	.360	.0045	.200	6	.7500	4.0	TM-720-20	150.50	TM-720-20X	165.15
5 - 12	.720	2.000	.360	.0045	.200	6	.7500	4.0	TM-720-32	150.50	TM-720-32X	165.15
5 - 12	.720	2.500	.360	.0045	.200	6	.7500	4.0	TM-720-40	150.50	TM-720-40X	165.15

TM

Thread Milling Cutters Single Form - UN Threads - Reduced Shank

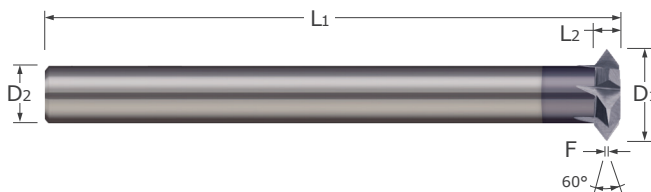

- Mills internal and external 60° threads
- Single thread form designed to mill common UN and metric pitch sizes
- Single form design reduces tool pressure for deep thread milling applications
- Reduced shank design can be chucked at any depth
- Mills right hand and left hand threads
- AlTiN coating option for added lubricity and increased wear resistance in difficult-to-machine materials
- Carbide head brazed to carbide shank
- CNC ground in the USA

Threads Per Inch	Cutter Diameter	Flat	Cutter Width	Flutes	Shank Diameter	Overall Length	Uncoated		AlTiN Coated	
							Tool #	Price	Tool #	Price
TPI	$D_1 \begin{smallmatrix} +.000'' \\ -.005'' \end{smallmatrix}$	$F \begin{smallmatrix} +.0030'' \\ -.0000'' \end{smallmatrix}$	$L_2 \begin{smallmatrix} +.005'' \\ -.005'' \end{smallmatrix}$		D_2 (h6)	L_1				
12-32	.375	.0020	.093	4	.2500	2.59	TM-375*	81.55	TM-375X*	86.30
11-32	.500	.0020	.125	5	.3125	2.63	TM-500*	99.30	TM-500X*	106.00
7-16	.750	.0040	.156	6	.3750	2.65	TM-750	123.15	TM-750X	129.65
5-12	1.000	.0045	.187	7	.5000	3.20	TM-001	160.85	TM-001X	168.55

* Reduced Neck



Thread Milling Cutters

Multi-Form – UN Threads

TM

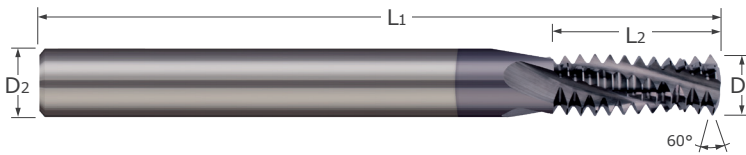

Thread Milling Cutters

- Mills internal and external 60° UN threads
- Able to cut larger threads of the same pitch
- 100% thread form creates superior threads vs. tapping
- Mills right and left hand threads
- Helical flutes
- AlTiN coating option for added lubricity and increased wear resistance in difficult-to-machine materials
- Solid carbide
- CNC ground in the USA

Thread Size	Cutter Diameter D1 \pm .0005" -.0005"	Length of Cut* L2 \pm .0500" -.0000"	Flutes	Shank Diameter D2 (h6)	Overall Length L1	Uncoated		AlTiN Coated	
						Tool #	Price	Tool #	Price
4-40	.0800	.1875	2	.2500	2.0			TM-112-40X	143.50
6-32	.1000	.2500	2	.2500	2.0	TM-138-32	140.60	TM-138-32X	142.55
8-32	.1150	.2500	3	.2500	2.0			TM-164-32X	143.50
10-24	.1200	.3125	3	.2500	2.0	TM-190-24	146.70	TM-190-24X	148.65
10-28	.1200	.3125	3	.2500	2.0			TM-190-28X	148.65
10-32	.1200	.3125	3	.2500	2.0	TM-190-32	146.70	TM-190-32X	148.65
1/4-20	.1800	.5000	3	.2500	2.5	TM-250-20	153.05	TM-250-20X	157.15
1/4-28	.1800	.5000	3	.2500	2.5	TM-250-28	153.05	TM-250-28X	157.15
5/16-18	.2350	.6250	3	.2500	2.5	TM-312-18	167.65	TM-312-18X	171.55
5/16-24	.2350	.6250	3	.2500	2.5			TM-312-24X	171.55
3/8-16	.2850	.7500	4	.3125	2.5	TM-375-16	202.20	TM-375-16X	209.50
3/8-24	.2850	.7500	4	.3125	2.5	TM-375-24	202.20	TM-375-24X	209.50
7/16-14	.3050	.7500	4	.3125	2.5	TM-437-14	202.20	TM-437-14X	209.50
7/16-20	.3350	.8750	4	.3750	3.0	TM-437-20	212.40	TM-437-20X	218.10
1/2-13	.3500	.8750	4	.3750	3.0	TM-500-13	212.40	TM-500-13X	218.10
9/16-12	.3700	.8750	4	.3750	3.0			TM-562-12X	218.10
9/16-18	.3700	.8750	4	.3750	3.0	TM-562-18	212.40	TM-562-18X	218.10
5/8-11	.4700	1.2500	4	.5000	4.0			TM-625-11X	254.05
3/4-10	.4950	1.2500	4	.5000	4.0	TM-750-10	243.20	TM-750-10X	252.55
3/4-12	.4950	1.2500	4	.5000	4.0	TM-750-12	243.20	TM-750-12X	252.55
3/4-16	.4950	1.2500	4	.5000	4.0	TM-750-16	243.20	TM-750-16X	252.55
7/8-14	.4900	1.2500	4	.5000	4.0	TM-875-14	244.15	TM-875-14X	253.50
7/8-9	.6200	1.3750	4	.6250	4.0			TM-875-09X	271.45
1-8	.6200	1.3750	4	.6250	4.0	TM-001-08	261.95	TM-001-08X	274.85

* Length of cut measured to last full tooth.

TM

Thread Milling Cutters Multi-Form – NPT Threads

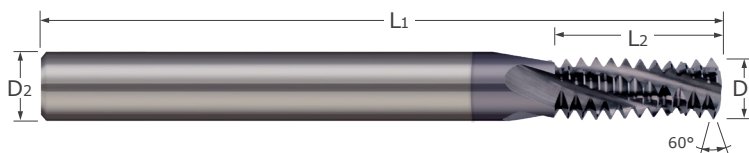

- Mills internal and external 60° NPT threads
- 100% thread form creates superior threads vs. tapping
- Mills right hand and left hand threads
- Helical flutes
- AlTiN coating option for added lubricity and increased wear resistance in difficult-to-machine materials
- Solid carbide ■ CNC ground in the USA

Thread Size	Major Cutter Diameter $D_1 \begin{smallmatrix} +.0005'' \\ -.0005'' \end{smallmatrix}$	Length of Cut* $L_2 \begin{smallmatrix} +.050'' \\ -.000'' \end{smallmatrix}$	Flutes	Shank Diameter D_2 (h6)	Overall Length L_1	Uncoated		AlTiN Coated	
						Tool #	Price	Tool #	Price
1/16 & 1/8-27 NPT	.2450	.437	3	.2500	2.5	TM-27NPT	168.20	TM-27NPTX	172.15
1/4 & 3/8-18 NPT	.3050	.625	4	.3125	3.0	TM-18NPT	202.80	TM-18NPTX	210.10
1/2 & 3/4-14 NPT	.4950	.875	4	.5000	4.0	TM-14NPT	204.25	TM-14NPTX	213.90
1 & 2-11.5 NPT	.6200	1.125	4	.6250	4.0	TM-11NPT	272.00	TM-11NPTX	283.40

* Length of cut measured to last full tooth.

Thread Milling Cutters

TM

Thread Milling Cutters Multi-Form – NPTF Threads

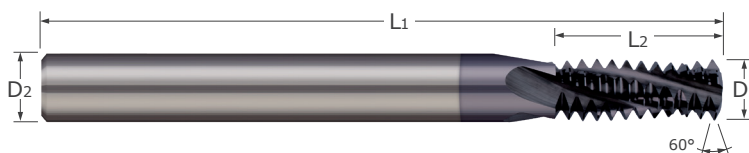

- Mills internal and external 60° NPTF threads
- 100% thread form creates superior threads vs. tapping
- Mills right hand and left hand threads
- Helical flutes
- AlTiN coating option for added lubricity and increased wear resistance in difficult-to-machine materials
- Solid carbide ■ CNC ground in the USA

Thread Size	Major Cutter Diameter $D_1 \begin{smallmatrix} +.0005'' \\ -.0005'' \end{smallmatrix}$	Length of Cut* $L_2 \begin{smallmatrix} +.030'' \\ -.000'' \end{smallmatrix}$	Flutes	Shank Diameter D_2 (h6)	Overall Length L_1	Uncoated		AlTiN Coated	
						Tool #	Price	Tool #	Price
1/16 & 1/8-27 NPT	.2450	.437	3	.2500	2.5	TM-27NPTF	191.20	TM-27NPTFX	194.95
1/4 & 3/8-18 NPT	.3050	.625	4	.3125	3.0			TM-18NPTFX	223.30
1/2 & 3/4-14 NPT	.4950	.875	4	.5000	4.0	TM-14NPTF	235.10		
1 & 2-11.5 NPT	.6200	1.125	4	.6250	4.0			TM-11NPTFX	324.80

* Length of cut measured to last full tooth.

Thread Milling Cutters

TMM

Multi-Form – Metric Threads

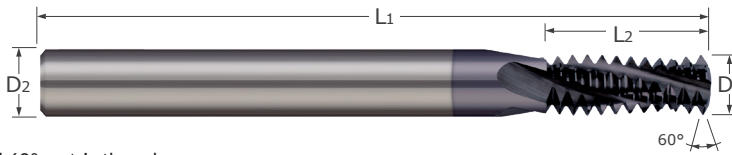

- Mills internal and external 60° metric thread
- Able to cut larger threads of the same pitch
- 100% thread form creates superior threads vs. tapping
- Mills right hand threads
- Helical flutes
- AlTiN coating option for added lubricity and increased wear resistance in difficult-to-machine materials
- Solid carbide ■ CNC ground in the USA

Thread Milling Cutters

Thread Size	Cutter Diameter	Length of Cut*	Flutes	Shank Diameter	Overall Length	Uncoated		AlTiN Coated	
						Tool #	Price	Tool #	Price
	D1 (h8)	L2 $\begin{smallmatrix} +1.3 \\ -0.0 \end{smallmatrix}$ mm		D2 (h6)	L1				
M4.5x0.75	3.00 mm	6 mm	3	6 mm	57 mm	TMM-045075	139.00	TMM-045075X	143.20
M5.0x0.80	3.00 mm	8 mm	3	6 mm	57 mm			TMM-050080X	143.20
M6.0x1.00	4.30 mm	12 mm	3	6 mm	57 mm			TMM-060100X	159.05
M8.0x0.75	6.00 mm	16 mm	3	6 mm	57 mm	TMM-080075	194.35	TMM-080075X	198.05
M8.0x1.25	6.00 mm	16 mm	3	6 mm	57 mm			TMM-080125X	198.05
M10.0x1.50	7.62 mm	20 mm	4	8 mm	100 mm	TMM-100150	220.35	TMM-100150X	225.95
M12.0x1.00	9.15 mm	22 mm	4	10 mm	100 mm			TMM-120100X	228.30
M12.0x1.75	9.15 mm	22 mm	4	10 mm	100 mm			TMM-120175X	228.30
M18.0x1.50	11.94 mm	32 mm	4	12 mm	100 mm	TMM-180150	269.70	TMM-180150X	282.40
M20.0x2.50	11.94 mm	32 mm	4	12 mm	100 mm			TMM-200250X	282.40
M24.0x3.00	15.75 mm	35 mm	4	16 mm	100 mm	TMM-240300	314.60		

* Length of cut measured to last full tooth.

Thread Milling Cutters

MTR

Thread Relief Cutter

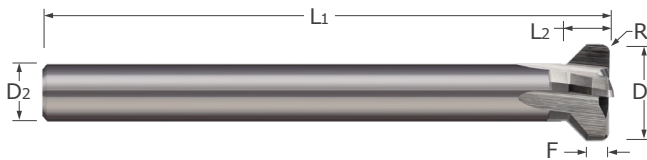

- Designed for milling thread relief at the bottom of a thread
- Relief operation typically done before threading to avoid thread form damage
- Chamfer eliminates burrs and partial threads at last thread
- Carbide head brazed to carbide shank
- CNC ground in the USA

Cutter Diameter	Cutter Width	Flat	Radius	Flutes	Shank Diameter	Overall Length	Uncoated	
							Tool #	Price
D1 $\begin{smallmatrix} +.000 \\ -.005 \end{smallmatrix}$ "	L2 $\begin{smallmatrix} +.015 \\ -.015 \end{smallmatrix}$ "	F $\begin{smallmatrix} +.000 \\ -.005 \end{smallmatrix}$ "	R $\begin{smallmatrix} +.002 \\ -.002 \end{smallmatrix}$ "		D2 (h6)	L1		
.375	.141	.075	.010	4	.2500	2.64	MTR-375	83.00
.500	.195	.100	.010	5	.3125	2.72	MTR-500	101.20
.750	.250	.125	.015	6	.3750	2.75	MTR-750	125.55
1.000	.250	.125	.015	7	.5000	3.25	MTR-001	163.80

MILLING TOOLS

End Mills

End Mills - Square	216
End Mills - Ball	228
End Mills - Corner Radius	236

Material Specific End Mills

End Mills for Hardened Steels	239
End Mills for Steels & High Temp Alloys	240
End Mills for Aluminum Alloys	274
End Mills for Plastics & Composites	277

Specialty Profiles

Undercutting End Mills	283
Drill/End Mills	285
Chamfer Cutters	287
Runner Cutters	288
Engraving Cutters	289
Keyseat Cutters	293
Corner Rounding End Mills	295
Dovetail Cutters	297

Indexable

298



End Mills – Square

2 Flute – Stub & Standard – Miniature

RME / RMEM
SME / AMRM

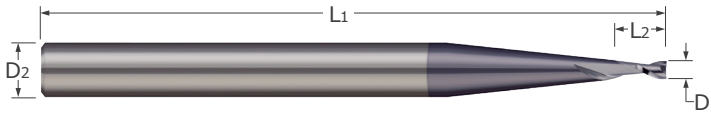

End Mills

- Designed for general purpose micromachining
- Cutter diameter down to .005"
- 30° helix ■ Center cutting ■ Square profile
- AlTiN coating option for added lubricity and increased wear resistance in difficult-to-machine materials
- Solid carbide ■ CNC ground in the USA

Cutter Diameter*			Length of Cut	Flutes	Shank Diameter	Overall Length	Uncoated		AlTiN Coated	
D1			L2		D2 (h6)	L1	Tool #	Price	Tool #	Price
+ .0005"	+ .00 mm	decimal equiv.	+ .010"							
– .0005"	– .02 mm		– .000"							
			+ .25 mm							
			– .00 mm							
.0050		.0050	.007	2	.1250	1.5	SME-005-2	49.25	SME-005-2X	51.55
.0060		.0060	.009	2	.1250	1.5	SME-006-2	49.25	SME-006-2X	51.55
.0070		.0070	.010	2	.1250	1.5	SME-007-2	41.75	SME-007-2X	44.15
	0.2 mm	.0079	0.4 mm	2	3 mm	38 mm	RMEM-002-2	34.70	RMEM-002-2X	37.20
	0.2 mm	.0079	0.4 mm	2	4 mm	50 mm			AMRM-002-2X	40.55
.0080		.0080	.012	2	.1250	1.5	SME-008-2	41.75	SME-008-2X	44.15
.0090		.0090	.013	2	.1250	1.5	SME-009-2	37.95	SME-009-2X	40.40
.0100		.0100	.015	2	.1250	1.5	SME-010-2	37.95	SME-010-2X	40.40
.0100		.0100	.030	2	.1250	1.5	RME-010-2	39.65	RME-010-2X	42.10
.0110		.0110	.016	2	.1250	1.5	SME-011-2	34.30		
.0110		.0110	.033	2	.1250	1.5			RME-011-2X	38.35
	0.3 mm	.0118	0.9 mm	2	3 mm	38 mm	RMEM-003-2	29.90	RMEM-003-2X	32.45
	0.3 mm	.0118	0.9 mm	2	4 mm	50 mm	AMRM-003-2	32.90	AMRM-003-2X	35.85
.0120		.0120	.018	2	.1250	1.5	SME-012-2	34.30	SME-012-2X	36.80
.0120		.0120	.036	2	.1250	1.5	RME-012-2	35.90	RME-012-2X	38.35
.0130		.0130	.019	2	.1250	1.5	SME-013-2	29.15	SME-013-2X	31.70
.0130		.0130	.039	2	.1250	1.5	RME-013-2	30.55	RME-013-2X	33.00
.0140		.0140	.021	2	.1250	1.5	SME-014-2	29.15	SME-014-2X	31.70
.0140		.0140	.042	2	.1250	1.5	RME-014-2	30.55	RME-014-2X	33.00
.0150		.0150	.022	2	.1250	1.5	SME-015-2	23.20	SME-015-2X	25.80
.0150		.0150	.045	2	.1250	1.5	RME-015-2	24.20	RME-015-2X	26.80
	0.4 mm	.0157	1.2 mm	2	3 mm	38 mm	RMEM-004-2	21.95		
	0.4 mm	.0157	1.2 mm	2	4 mm	50 mm	AMRM-004-2	25.00		
.0160		.0160	.024	2	.1250	1.5	SME-016-2	23.20	SME-016-2X	25.80
.0160		.0160	.048	2	.1250	1.5	RME-016-2	24.20	RME-016-2X	26.80
.0170		.0170	.025	2	.1250	1.5	SME-017-2	23.20	SME-017-2X	25.80
.0170		.0170	.051	2	.1250	1.5	RME-017-2	24.20	RME-017-2X	26.80
.0180		.0180	.027	2	.1250	1.5	SME-018-2	23.20	SME-018-2X	25.80
.0180		.0180	.054	2	.1250	1.5	RME-018-2	24.20	RME-018-2X	26.80
.0190		.0190	.028	2	.1250	1.5	SME-019-2	23.20		
.0190		.0190	.057	2	.1250	1.5			RME-019-2X	26.80
	0.5 mm	.0197	1.5 mm	2	3 mm	38 mm	RMEM-005-2	20.25	RMEM-005-2X	22.85
	0.5 mm	.0197	1.5 mm	2	4 mm	50 mm	AMRM-005-2	21.90	AMRM-005-2X	24.95

*.0005" / .013 mm max TIR

Continued on next page

RME / RMEM
SME / AMRM

End Mills – Square

2 Flute – Stub & Standard – Miniature (cont.)

Continued from previous page

Cutter Diameter*			Length of Cut	Flutes	Shank Diameter	Overall Length	Uncoated		AlTiN Coated	
D1 +.0005" -.0005"	+.00 mm -.02 mm	decimal equiv.	L2 +.010" -.000" +.25 mm -.00 mm	2	D2 (h6)	L1	Tool #	Price	Tool #	Price
.0200	.0200	.0200	.030	2	.1250	1.5	SME-020-2	21.35	SME-020-2X	24.00
.0200	.0200	.0200	.060	2	.1250	1.5	RME-020-2	22.35	RME-020-2X	24.95
.0210	.0210	.0210	.063	2	.1250	1.5	RME-021-2	22.35	RME-021-2X	24.95
.0220	.0220	.0220	.033	2	.1250	1.5	SME-022-2	21.35	SME-022-2X	24.00
.0220	.0220	.0220	.066	2	.1250	1.5	RME-022-2	22.35	RME-022-2X	24.95
.0230	.0230	.0230	.034	2	.1250	1.5	SME-023-2	21.35	SME-023-2X	24.00
.0230	.0230	.0230	.069	2	.1250	1.5	RME-023-2	22.35	RME-023-2X	24.95
0.6 mm	.0236	.0236	1.8 mm	2	3 mm	38 mm	RMEM-006-2	20.25	RMEM-006-2X	22.85
.0240	.0240	.0240	.036	2	.1250	1.5	SME-024-2	21.35		
.0240	.0240	.0240	.072	2	.1250	1.5	RME-024-2	22.35	RME-024-2X	24.95
.0250	.0250	.0250	.037	2	.1250	1.5	SME-025-2	21.35	SME-025-2X	24.00
.0250	.0250	.0250	.075	2	.1250	1.5	RME-025-2	22.35	RME-025-2X	24.95
.0260	.0260	.0260	.039	2	.1250	1.5			SME-026-2X	21.40
.0270	.0270	.0270	.040	2	.1250	1.5	SME-027-2	18.75	SME-027-2X	21.40
.0270	.0270	.0270	.081	2	.1250	1.5	RME-027-2	18.85	RME-027-2X	21.50
0.7 mm	.0276	.0276	2.1 mm	2	3 mm	38 mm	RMEM-007-2	18.15	RMEM-007-2X	20.80
0.7 mm	.0276	.0276	2.1 mm	2	4 mm	50 mm			AMRM-007-2X	22.75
.0280	.0280	.0280	.042	2	.1250	1.5			SME-028-2X	21.40
.0280	.0280	.0280	.084	2	.1250	1.5	RME-028-2	18.85	RME-028-2X	21.50
.0290	.0290	.0290	.043	2	.1250	1.5	SME-029-2	18.75	SME-029-2X	21.40
.0290	.0290	.0290	.087	2	.1250	1.5	RME-029-2	18.85	RME-029-2X	21.50
.0300	.0300	.0300	.045	2	.1250	1.5	SME-030-2	18.75	SME-030-2X	21.40
.0300	.0300	.0300	.090	2	.1250	1.5	RME-030-2	18.85	RME-030-2X	21.50
.0310	.0310	.0310	.047	2	.1250	1.5	SME-031-2	18.75	SME-031-2X	21.40
0.8 mm	.0315	.0315	2.4 mm	2	3 mm	38 mm	RMEM-008-2	18.15	RMEM-008-2X	20.80
0.8 mm	.0315	.0315	2.4 mm	2	4 mm	50 mm	AMRM-008-2	19.65		
.0320	.0320	.0320	.096	2	.1250	1.5	RME-032-2	18.85	RME-032-2X	21.50
.0340	.0340	.0340	.102	2	.1250	1.5			RME-034-2X	21.50
.0350	.0350	.0350	.105	2	.1250	1.5	RME-035-2	18.85	RME-035-2X	21.50
0.9 mm	.0354	.0354	2.7 mm	2	3 mm	38 mm	RMEM-009-2	18.15	RMEM-009-2X	20.80
0.9 mm	.0354	.0354	2.7 mm	2	4 mm	50 mm			AMRM-009-2X	22.75
1 mm	.0394	.0394	3 mm	2	3 mm	38 mm	RMEM-010-2	18.15	RMEM-010-2X	20.80
1 mm	.0394	.0394	3 mm	2	4 mm	50 mm	AMRM-010-2	19.65	AMRM-010-2X	22.75
.0400	.0400	.0400	.060	2	.1250	1.5	SME-040-2	18.75	SME-040-2X	21.40
.0400	.0400	.0400	.120	2	.1250	1.5	RME-040-2	18.85	RME-040-2X	21.50
1.1 mm	.0433	.0433	3.3 mm	2	3 mm	38 mm	RMEM-011-2	18.15	RMEM-011-2X	20.80
1.1 mm	.0433	.0433	3.3 mm	2	4 mm	50 mm	AMRM-011-2	19.65		
.0450	.0450	.0450	.068	2	.1250	1.5	SME-045-2	18.75	SME-045-2X	21.40
.0450	.0450	.0450	.135	2	.1250	1.5			RME-045-2X	21.50
1.2 mm	.0472	.0472	3.8 mm	2	3 mm	38 mm	RMEM-012-2	18.15	RMEM-012-2X	20.80
1.2 mm	.0472	.0472	3.8 mm	2	4 mm	50 mm	AMRM-012-2	19.65	AMRM-012-2X	22.75

*.0005" / .013 mm max TIR

Continued on next page

End Mills – Square

2 Flute – Stub & Standard – Miniature (cont.)

RME / RMEM
SME / AMRM

Continued from previous page

End Mills

Cutter Diameter*			Length of Cut	Flutes	Shank Diameter	Overall Length	Uncoated		AITIN Coated	
D1 +.0005" -.0005"	+.00 mm -.02 mm	decimal equiv.	L2 +.010" -.000" +.25 mm -.00 mm	D2 (h6)	L1	Tool #	Price	Tool #	Price	
.0500		.0500	.075	2	.1250	1.5	SME-050-2	18.75	SME-050-2X	21.40
.0500		.0500	.150	2	.1250	1.5	RME-050-2	18.85	RME-050-2X	21.50
1.3 mm		.0512	3.9 mm	2	3 mm	38 mm	RMEM-013-2	18.15	RMEM-013-2X	20.80
1.3 mm		.0512	3.9 mm	2	4 mm	50 mm	AMRM-013-2	19.65	AMRM-013-2X	22.75
1.4 mm		.0551	4.2 mm	2	3 mm	38 mm	RMEM-014-2	18.15	RMEM-014-2X	20.80
1.4 mm		.0551	4.2 mm	2	4 mm	50 mm			AMRM-014-2X	22.75
1.5 mm		.0591	4.2 mm	2	3 mm	38 mm	RMEM-015-2	18.15	RMEM-015-2X	20.80
1.5 mm		.0591	4.2 mm	2	4 mm	50 mm	AMRM-015-2	19.65	AMRM-015-2X	22.75
1.6 mm		.0630	4.8 mm	2	3 mm	38 mm	RMEM-016-2	16.80		
1.6 mm		.0630	4.8 mm	2	4 mm	50 mm	AMRM-016-2	19.65	AMRM-016-2X	22.75
1.7 mm		.0669	5.1 mm	2	3 mm	38 mm	RMEM-017-2	16.80	RMEM-017-2X	19.45
1.7 mm		.0669	5.1 mm	2	4 mm	50 mm			AMRM-017-2X	22.75
1.8 mm		.0709	5.3 mm	2	3 mm	38 mm	RMEM-018-2	16.80		
1.8 mm		.0709	5.3 mm	2	4 mm	50 mm	AMRM-018-2	19.65	AMRM-018-2X	22.75
1.9 mm		.0748	5.7 mm	2	3 mm	38 mm	RMEM-019-2	16.80	RMEM-019-2X	19.45
1.9 mm		.0748	5.7 mm	2	4 mm	50 mm	AMRM-019-2	19.65	AMRM-019-2X	22.75
2 mm		.0787	6 mm	2	3 mm	38 mm	RMEM-020-2	16.80	RMEM-020-2X	19.45
2 mm		.0787	6 mm	2	4 mm	50 mm	AMRM-020-2	19.65	AMRM-020-2X	22.75
2.5 mm		.0984	8 mm	2	3 mm	38 mm	RMEM-025-2	16.80	RMEM-025-2X	19.45
2.5 mm		.0984	8 mm	2	4 mm	50 mm	AMRM-025-2	19.65	AMRM-025-2X	22.75
3 mm		.1181	9 mm	2	4 mm	50 mm	AMRM-030-2	19.65	AMRM-030-2X	22.75

*.0005" / .013 mm max TIR

**GEM / GEMM
SEM / AEMM**

End Mills – Square
2, 3, 4 Flute

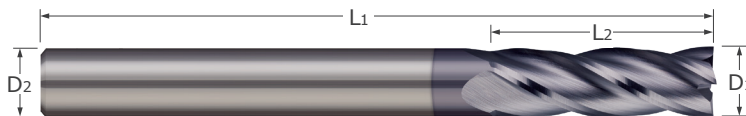

- Designed for general purpose machining
- 30° helix ■ Center cutting ■ Square profile
- AlTiN coating option for added lubricity and increased wear resistance in difficult-to-machine materials
- Solid carbide ■ CNC ground in the USA

Cutter Diameter*			Length of Cut	Flutes	Shank Diameter	Overall Length	Uncoated		AlTiN Coated	
D1			L2		D2 (h6)	L1	Tool #	Price	Tool #	Price
+ .0000" - .0020"	(h9)	decimal equiv.	+ .030" - .000" + .78 mm - .00 mm							
.0312		.0312	.063	2	.1250	1.5	SEM-031-02	16.15	SEM-031-02X	18.80
.0312		.0312	.063	3	.1250	1.5	SEM-031-03	16.15	SEM-031-03X	18.80
.0312		.0312	.063	4	.1250	1.5	SEM-031-04	16.15	SEM-031-04X	18.80
.0312		.0312	.078	2	.1250	1.5	GEM-031-2	16.90	GEM-031-2X	19.55
.0312		.0312	.078	3	.1250	1.5	GEM-031-3	16.90	GEM-031-3X	19.55
.0312		.0312	.078	4	.1250	1.5	GEM-031-4	16.90	GEM-031-4X	19.55
	1 mm	.0394	3 mm	2	3 mm	38 mm	GEMM-010-2	16.20	GEMM-010-2X	18.85
	1 mm	.0394	3 mm	3	3 mm	38 mm	GEMM-010-3	16.20	GEMM-010-3X	18.85
	1 mm	.0394	3 mm	4	3 mm	38 mm	GEMM-010-4	16.20		
	1 mm	.0394	4 mm	2	4 mm	50 mm			AEMM-010-2X	22.75
	1 mm	.0394	4 mm	3	4 mm	50 mm	AEMM-010-3	19.65	AEMM-010-3X	22.75
	1 mm	.0394	4 mm	4	4 mm	50 mm	AEMM-010-4	19.65	AEMM-010-4X	22.75
.0469		.0469	.094	2	.1250	1.5	SEM-046-02	16.15	SEM-046-02X	18.80
.0469		.0469	.094	3	.1250	1.5	SEM-046-03	16.15	SEM-046-03X	18.80
.0469		.0469	.094	4	.1250	1.5	SEM-046-04	16.15	SEM-046-04X	18.80
.0469		.0469	.109	2	.1250	1.5	GEM-046-2	16.90	GEM-046-2X	19.55
.0469		.0469	.109	3	.1250	1.5	GEM-046-3	16.90	GEM-046-3X	19.55
.0469		.0469	.109	4	.1250	1.5	GEM-046-4	16.90	GEM-046-4X	19.55
	1.5 mm	.0591	4 mm	2	4 mm	50 mm	AEMM-015-2	19.65		
	1.5 mm	.0591	4 mm	3	4 mm	50 mm	AEMM-015-3	19.65	AEMM-015-3X	22.75
	1.5 mm	.0591	4 mm	4	4 mm	50 mm	AEMM-015-4	19.65	AEMM-015-4X	22.75
.0625		.0625	.125	2	.1250	1.5	SEM-062-02	14.65	SEM-062-02X	17.30
.0625		.0625	.125	3	.1250	1.5	SEM-062-03	14.65	SEM-062-03X	17.30
.0625		.0625	.125	4	.1250	1.5	SEM-062-04	14.65	SEM-062-04X	17.30
.0625		.0625	.188	2	.1250	1.5	GEM-062-2	15.50	GEM-062-2X	18.15
.0625		.0625	.188	3	.1250	1.5	GEM-062-3	15.50	GEM-062-3X	18.15
.0625		.0625	.188	4	.1250	1.5	GEM-062-4	15.50	GEM-062-4X	18.15
.0781		.0781	.156	2	.1250	1.5	SEM-078-02	14.65	SEM-078-02X	17.30
.0781		.0781	.156	3	.1250	1.5	SEM-078-03	14.65	SEM-078-03X	17.30
.0781		.0781	.156	4	.1250	1.5	SEM-078-04	14.65	SEM-078-04X	17.30
.0781		.0781	.188	2	.1250	1.5	GEM-078-2	15.50	GEM-078-2X	18.15
.0781		.0781	.188	3	.1250	1.5	GEM-078-3	15.50	GEM-078-3X	18.15
.0781		.0781	.188	4	.1250	1.5	GEM-078-4	15.50	GEM-078-4X	18.15
	2 mm	.0787	5 mm	2	4 mm	50 mm	AEMM-020-2	19.65	AEMM-020-2X	22.75
	2 mm	.0787	5 mm	3	4 mm	50 mm	AEMM-020-3	19.65	AEMM-020-3X	22.75
	2 mm	.0787	5 mm	4	4 mm	50 mm	AEMM-020-4	19.65	AEMM-020-4X	22.75
	2 mm	.0787	6 mm	2	3 mm	38 mm	GEMM-020-2	14.70	GEMM-020-2X	17.40
	2 mm	.0787	6 mm	3	3 mm	38 mm			GEMM-020-3X	17.40
	2 mm	.0787	7 mm	4	3 mm	38 mm	GEMM-020-4	14.70	GEMM-020-4X	17.40

*.0005" / .013 mm max TIR

Continued on next page

End Mills – Square

2, 3, 4 Flute (cont.)

GEM / GEMM
SEM / AEMM

Continued from previous page

End Mills

Cutter Diameter*		Length of Cut L ₂	Flutes	Shank Diameter D ₂ (h6)	Overall Length L ₁	Uncoated		AITIN Coated	
D ₁ + .0000" - .0020" (h9)	decimal equiv.					Tool #	Price	Tool #	Price
.0938	.0938	.188	2	.1250	1.5	SEM-093-02	14.65	SEM-093-02X	17.30
.0938	.0938	.188	3	.1250	1.5	SEM-093-03	14.65	SEM-093-03X	17.30
.0938	.0938	.188	4	.1250	1.5	SEM-093-04	14.65	SEM-093-04X	17.30
.0938	.0938	.375	2	.1250	1.5	GEM-093-2	15.50	GEM-093-2X	18.15
.0938	.0938	.375	3	.1250	1.5	GEM-093-3	15.50	GEM-093-3X	18.15
.0938	.0938	.375	4	.1250	1.5	GEM-093-4	15.50	GEM-093-4X	18.15
2.5 mm	.0984	6 mm	2	4 mm	50 mm	AEMM-025-2	19.65	AEMM-025-2X	22.75
2.5 mm	.0984	6 mm	3	4 mm	50 mm	AEMM-025-3	19.65	AEMM-025-3X	22.75
2.5 mm	.0984	6 mm	4	4 mm	50 mm	AEMM-025-4	19.65	AEMM-025-4X	22.75
.1094	.1094	.188	2	.1250	1.5	SEM-109-02	14.65	SEM-109-02X	17.30
.1094	.1094	.188	3	.1250	1.5	SEM-109-03	14.65	SEM-109-03X	17.30
.1094	.1094	.188	4	.1250	1.5	SEM-109-04	14.65	SEM-109-04X	17.30
.1094	.1094	.375	2	.1250	1.5	GEM-109-2	15.50	GEM-109-2X	18.15
.1094	.1094	.375	3	.1250	1.5	GEM-109-3	15.50	GEM-109-3X	18.15
.1094	.1094	.375	4	.1250	1.5	GEM-109-4	15.50	GEM-109-4X	18.15
3 mm	.1181	7 mm	2	3 mm	38 mm	GEMM-030-2	13.15	GEMM-030-2X	15.85
3 mm	.1181	7 mm	3	3 mm	38 mm	GEMM-030-3	13.15	GEMM-030-3X	15.85
3 mm	.1181	8 mm	4	3 mm	38 mm	GEMM-030-4	13.15	GEMM-030-4X	15.85
3 mm	.1181	8 mm	2	6 mm	57 mm	AEMM-030-2	24.65	AEMM-030-2X	29.95
3 mm	.1181	8 mm	3	6 mm	57 mm	AEMM-030-3	24.65		
3 mm	.1181	8 mm	4	6 mm	57 mm	AEMM-030-4	24.65	AEMM-030-4X	29.95
.1250	.1250	.250	2	.1250	1.5	SEM-125-02	13.05	SEM-125-02X	15.75
.1250	.1250	.250	3	.1250	1.5	SEM-125-03	13.05	SEM-125-03X	15.75
.1250	.1250	.250	4	.1250	1.5	SEM-125-04	13.05	SEM-125-04X	15.75
.1250	.1250	.500	2	.1250	1.5	GEM-125-2	13.80	GEM-125-2X	16.50
.1250	.1250	.500	3	.1250	1.5	GEM-125-3	13.80	GEM-125-3X	16.50
.1250	.1250	.500	4	.1250	1.5	GEM-125-4	13.80	GEM-125-4X	16.50
3.5 mm	.1378	10 mm	2	6 mm	57 mm			AEMM-035-2X	29.95
3.5 mm	.1378	10 mm	3	6 mm	57 mm	AEMM-035-3	24.65	AEMM-035-3X	29.95
3.5 mm	.1378	10 mm	4	6 mm	57 mm	AEMM-035-4	24.65	AEMM-035-4X	29.95
.1406	.1406	.250	2	.1875	1.5	SEM-140-02	20.85	SEM-140-02X	23.90
.1406	.1406	.250	3	.1875	1.5	SEM-140-03	20.85	SEM-140-03X	23.90
.1406	.1406	.250	4	.1875	1.5	SEM-140-04	20.85	SEM-140-04X	23.90
.1406	.1406	.500	2	.1875	2.0	GEM-140-2	21.85	GEM-140-2X	24.90
.1406	.1406	.500	3	.1875	2.0	GEM-140-3	21.85	GEM-140-3X	24.90
.1406	.1406	.500	4	.1875	2.0	GEM-140-4	21.85	GEM-140-4X	24.90
.1562	.1562	.313	2	.1875	1.5	SEM-156-02	20.85	SEM-156-02X	23.90
.1562	.1562	.313	3	.1875	1.5	SEM-156-03	20.85	SEM-156-03X	23.90
.1562	.1562	.313	4	.1875	1.5	SEM-156-04	20.85	SEM-156-04X	23.90
.1562	.1562	.563	2	.1875	2.0	GEM-156-2	21.85	GEM-156-2X	24.90
.1562	.1562	.563	3	.1875	2.0	GEM-156-3	21.85	GEM-156-3X	24.90
.1562	.1562	.563	4	.1875	2.0	GEM-156-4	21.85	GEM-156-4X	24.90
4 mm	.1575	8 mm	2	4 mm	50 mm	GEMM-040-2	19.65		
4 mm	.1575	8 mm	3	4 mm	50 mm	GEMM-040-3	19.65		
4 mm	.1575	11 mm	4	4 mm	50 mm	GEMM-040-4	19.65	GEMM-040-4X	22.75
4 mm	.1575	11 mm	2	6 mm	57 mm	AEMM-040-2	24.65	AEMM-040-2X	29.95
4 mm	.1575	11 mm	3	6 mm	57 mm	AEMM-040-3	24.65	AEMM-040-3X	29.95
4 mm	.1575	11 mm	4	6 mm	57 mm	AEMM-040-4	24.65	AEMM-040-4X	29.95

*.0005" / .013 mm max TIR

Continued on next page

**GEM / GEMM
SEM / AEMM**

**End Mills – Square
2, 3, 4 Flute (cont.)**

Continued from previous page

Cutter Diameter*		Length of Cut L2	Flutes	Shank Diameter D2 (h6)	Overall Length L1	Uncoated		AITIN Coated	
D1 +.0000" -.0020" (h9)	decimal equiv.					Tool #	Price	Tool #	Price
.1719	.1719	.313	3	.1875	1.5	SEM-171-03	20.85	SEM-171-03X	23.90
.1719	.1719	.313	4	.1875	1.5	SEM-171-04	20.85	SEM-171-04X	23.90
.1719	.1719	.625	2	.1875	2.0	GEM-171-2	21.85	GEM-171-2X	24.90
.1719	.1719	.625	4	.1875	2.0	GEM-171-4	21.85	GEM-171-4X	24.90
4.5 mm	.1772	11 mm	3	6 mm	57 mm			AEMM-045-3X	29.95
4.5 mm	.1772	11 mm	4	6 mm	57 mm	AEMM-045-4	24.65	AEMM-045-4X	29.95
.1875	.1875	.375	2	.1875	1.5	SEM-187-02	20.85	SEM-187-02X	23.90
.1875	.1875	.375	3	.1875	1.5	SEM-187-03	20.85	SEM-187-03X	23.90
.1875	.1875	.375	4	.1875	1.5	SEM-187-04	20.85	SEM-187-04X	23.90
.1875	.1875	.625	2	.1875	2.0	GEM-187-2	21.85	GEM-187-2X	24.90
.1875	.1875	.625	3	.1875	2.0	GEM-187-3	21.85	GEM-187-3X	24.90
.1875	.1875	.625	4	.1875	2.0	GEM-187-4	21.85	GEM-187-4X	24.90
5 mm	.1969	10 mm	2	6 mm	57 mm	GEMM-050-2	21.00		
5 mm	.1969	13 mm	4	6 mm	57 mm	GEMM-050-4	21.00	GEMM-050-4X	24.10
5 mm	.1969	16 mm	2	6 mm	57 mm	AEMM-050-2	24.65	AEMM-050-2X	29.95
5 mm	.1969	16 mm	3	6 mm	57 mm			AEMM-050-3X	29.95
5 mm	.1969	16 mm	4	6 mm	57 mm	AEMM-050-4	24.65	AEMM-050-4X	29.95
.2031	.2031	.375	3	.2500	2.0	SEM-203-03	25.85	SEM-203-03X	28.95
.2031	.2031	.375	4	.2500	2.0	SEM-203-04	25.85	SEM-203-04X	28.95
.2031	.2031	.625	2	.2500	2.5	GEM-203-2	27.30		
.2031	.2031	.625	4	.2500	2.5	GEM-203-4	27.30	GEM-203-4X	32.55
5.5 mm	.2165	16 mm	2	6 mm	57 mm	AEMM-055-2	24.65		
5.5 mm	.2165	16 mm	4	6 mm	57 mm	AEMM-055-4	24.65	AEMM-055-4X	29.95
.2187	.2187	.438	4	.2500	2.0	SEM-218-04	25.85	SEM-218-04X	28.95
.2187	.2187	.625	2	.2500	2.5	GEM-218-2	27.30	GEM-218-2X	32.55
.2187	.2187	.625	4	.2500	2.5	GEM-218-4	27.30		
.2344	.2344	.438	4	.2500	2.0	SEM-234-04	25.85	SEM-234-04X	28.95
6 mm	.2362	10 mm	2	6 mm	57 mm	GEMM-060-2	24.65	GEMM-060-2X	29.95
6 mm	.2362	10 mm	3	6 mm	57 mm	GEMM-060-3	24.65		
6 mm	.2362	13 mm	4	6 mm	57 mm	GEMM-060-4	24.65	GEMM-060-4X	29.95
6 mm	.2362	16 mm	2	6 mm	57 mm	AEMM-060-2	24.65	AEMM-060-2X	29.95
6 mm	.2362	16 mm	3	6 mm	57 mm	AEMM-060-3	24.65	AEMM-060-3X	29.95
6 mm	.2362	16 mm	4	6 mm	57 mm	AEMM-060-4	24.65	AEMM-060-4X	29.95
.2500	.2500	.500	2	.2500	2.0	SEM-250-02	25.85	SEM-250-02X	28.95
.2500	.2500	.500	3	.2500	2.0	SEM-250-03	25.85	SEM-250-03X	28.95
.2500	.2500	.500	4	.2500	2.0	SEM-250-04	25.85	SEM-250-04X	28.95
.2500	.2500	.750	2	.2500	2.5	GEM-250-2	27.30	GEM-250-2X	32.55
.2500	.2500	.750	3	.2500	2.5	GEM-250-3	27.30	GEM-250-3X	32.55
.2500	.2500	.750	4	.2500	2.5	GEM-250-4	27.30	GEM-250-4X	32.55

D1 +.0000" -.0030" (h9)	decimal equiv.	L2 +.030" -.000" +.78 mm -.00 mm	D2 (h6)	L1	Tool #	Price	Tool #	Price	
.2656	.2656	.500	4	.3125	2.0	SEM-265-04	28.60	SEM-265-04X	35.50
7 mm	.2756	22 mm	3	8 mm	63 mm			AEMM-070-3X	37.85
7 mm	.2756	22 mm	4	8 mm	63 mm	AEMM-070-4	30.55	AEMM-070-4X	37.85
.2812	.2812	.500	4	.3125	2.0	SEM-281-04	28.60	SEM-281-04X	35.50

*.0005" / .013 mm max TIR

Continued on next page

End Mills

End Mills – Square

2, 3, 4 Flute (cont.)

GEM / GEMM
SEM / AEMM

Continued from previous page

End Mills

Cutter Diameter*		Length of Cut L ₂	Flutes	Shank Diameter D ₂ (h6)	Overall Length L ₁	Uncoated		AITIN Coated	
D ₁ + .0000" - .0030" (h9)	decimal equiv.					Tool #	Price	Tool #	Price
.2812	.2812	.750	2	.3125	2.5	GEM-281-2	31.75	GEM-281-2X	39.05
.2812	.2812	.750	3	.3125	2.5	GEM-281-3	31.75	GEM-281-3X	39.05
.2812	.2812	.750	4	.3125	2.5	GEM-281-4	31.75	GEM-281-4X	39.05
.3125	.3125	.500	2	.3125	2.0	SEM-312-02	28.60	SEM-312-02X	35.50
.3125	.3125	.500	4	.3125	2.0	SEM-312-04	28.60	SEM-312-04X	35.50
.3125	.3125	.813	2	.3125	2.5	GEM-312-2	31.75	GEM-312-2X	39.05
.3125	.3125	.813	4	.3125	2.5	GEM-312-4	31.75	GEM-312-4X	39.05
8 mm	.3150	16 mm	2	8 mm	63 mm	GEMM-080-2	30.55	GEMM-080-2X	37.85
8 mm	.3150	19 mm	4	8 mm	63 mm	GEMM-080-4	30.55		
8 mm	.3150	22 mm	2	8 mm	63 mm	AEMM-080-2	30.55		
8 mm	.3150	22 mm	3	8 mm	63 mm	AEMM-080-3	30.55	AEMM-080-3X	37.85
8 mm	.3150	22 mm	4	8 mm	63 mm	AEMM-080-4	30.55	AEMM-080-4X	37.85
.3281	.3281	.500	2	.3750	2.0	SEM-328-02	34.20	SEM-328-02X	40.40
.3281	.3281	.500	3	.3750	2.0	SEM-328-03	34.20	SEM-328-03X	40.40
.3281	.3281	.500	4	.3750	2.0	SEM-328-04	34.20		
.3750	.3750	.625	2	.3750	2.0	SEM-375-02	34.20	SEM-375-02X	39.70
.3750	.3750	.625	3	.3750	2.0	SEM-375-03	34.20	SEM-375-03X	39.70
.3750	.3750	.625	4	.3750	2.0	SEM-375-04	34.20	SEM-375-04X	39.70
.3750	.3750	.875	2	.3750	2.5	GEM-375-2	36.00	GEM-375-2X	43.30
.3750	.3750	.875	3	.3750	2.5	GEM-375-3	36.00	GEM-375-3X	43.30
.3750	.3750	.875	4	.3750	2.5	GEM-375-4	36.00	GEM-375-4X	43.30
.3906	.3906	.625	4	.4375	2.5	SEM-390-04	51.15	SEM-390-04X	59.90
10 mm	.3937	19 mm	2	10 mm	72 mm	GEMM-100-2	35.95	GEMM-100-2X	43.25
10 mm	.3937	19 mm	3	10 mm	72 mm	GEMM-100-3	35.95	GEMM-100-3X	43.25
10 mm	.3937	22 mm	4	10 mm	72 mm	GEMM-100-4	35.95	GEMM-100-4X	43.25
10 mm	.3937	22 mm	2	10 mm	72 mm	AEMM-100-2	35.95	AEMM-100-2X	43.25
10 mm	.3937	22 mm	3	10 mm	72 mm	AEMM-100-3	35.95	AEMM-100-3X	43.25
10 mm	.3937	22 mm	4	10 mm	72 mm	AEMM-100-4	35.95	AEMM-100-4X	43.25
11 mm	.4331	30 mm	3	12 mm	83 mm	AEMM-110-3	57.30		
.4375	.4375	1.000	4	.4375	2.5	GEM-437-4	56.80	GEM-437-4X	65.50
12 mm	.4724	22 mm	2	12 mm	83 mm	GEMM-120-2	57.30	GEMM-120-2X	68.30
12 mm	.4724	22 mm	3	12 mm	83 mm	GEMM-120-3	57.30		
12 mm	.4724	30 mm	2	12 mm	83 mm	AEMM-120-2	57.30	AEMM-120-2X	68.30
12 mm	.4724	30 mm	3	12 mm	83 mm	AEMM-120-3	57.30		
12 mm	.4724	30 mm	4	12 mm	83 mm	AEMM-120-4	57.30	AEMM-120-4X	68.30
.5000	.5000	.625	2	.5000	2.5	SEM-500-02	56.35	SEM-500-02X	64.85
.5000	.5000	.625	3	.5000	2.5	SEM-500-03	56.35	SEM-500-03X	64.85
.5000	.5000	.625	4	.5000	2.5	SEM-500-04	56.35	SEM-500-04X	64.85
.5000	.5000	1.000	2	.5000	3.0	GEM-500-2	62.55	GEM-500-2X	71.20
.5000	.5000	1.000	3	.5000	3.0	GEM-500-3	62.55	GEM-500-3X	71.20
.5000	.5000	1.000	4	.5000	3.0	GEM-500-4	62.55	GEM-500-4X	71.20
.5000	.5000	1.250	4	.5000	3.5			GEM-5125-4X	73.15
14 mm	.5512	26 mm	4	14 mm	83 mm	GEMM-140-4	66.50		
14 mm	.5512	35 mm	2	14 mm	83 mm			AEMM-140-2X	78.70
14 mm	.5512	35 mm	3	14 mm	83 mm	AEMM-140-3	66.50		
14 mm	.5512	35 mm	4	14 mm	83 mm	AEMM-140-4	66.50	AEMM-140-4X	78.70

*.0005" / .013 mm max TIR

Continued on next page

**GEM / GEMM
SEM / AEMM**

**End Mills – Square
2, 3, 4 Flute (cont.)**

Continued from previous page

Cutter Diameter*		Length of Cut	Flutes	Shank Diameter	Overall Length	Uncoated		AlTiN Coated	
D ₁ +.0000" -.0030" (h9)	decimal equiv.					L ₂ +.030" -.000" +.78 mm -.00 mm	D ₂ (h6)	L ₁	Tool #
.5625	.5625	1.250	2	.5625	3.5	GEM-562-2	96.05		
.5625	.5625	1.250	4	.5625	3.5	GEM-562-4	96.05	GEM-562-4X	109.00
.6250	.6250	1.250	4	.6250	3.5	GEM-625-4	110.40	GEM-625-4X	123.35
16 mm	.6299	32 mm	4	16 mm	92 mm	GEMM-160-4	106.10		
16 mm	.6299	35 mm	3	16 mm	92 mm			AEMM-160-3X	119.05
16 mm	.6299	35 mm	4	16 mm	92 mm	AEMM-160-4	106.10	AEMM-160-4X	119.05
18 mm	.7087	26 mm	2	18 mm	92 mm	GEMM-180-2	142.60		
18 mm	.7087	26 mm	3	18 mm	92 mm			GEMM-180-3X	157.35
18 mm	.7087	32 mm	4	18 mm	92 mm	GEMM-180-4	142.60		
18 mm	.7087	45 mm	3	18 mm	92 mm			AEMM-180-3X	157.35
.7500	.7500	1.500	2	.7500	4.0	GEM-750-2	168.30	GEM-750-2X	182.75
.7500	.7500	1.500	4	.7500	4.0	GEM-750-4	168.30	GEM-750-4X	182.75
20 mm	.7874	32 mm	3	20 mm	104 mm			GEMM-200-3X	202.00
20 mm	.7874	38 mm	4	20 mm	104 mm	GEMM-200-4	181.20		
20 mm	.7874	45 mm	2	20 mm	104 mm			AEMM-200-2X	202.00
20 mm	.7874	45 mm	3	20 mm	104 mm			AEMM-200-3X	202.00
.8750	.8750	1.500	4	.8750	4.0	GEM-875-4	233.20		
25 mm	.9843	50 mm	2	25 mm	127 mm			AEMM-250-2X	239.15
25 mm	.9843	50 mm	3	25 mm	127 mm	AEMM-250-3	215.55	AEMM-250-3X	239.15
25 mm	.9843	50 mm	4	25 mm	127 mm			AEMM-250-4X	239.15
1.0000	1.0000	1.500	4	1.0000	4.0	GEM-001-4	254.95		

*.0005" / .013 mm max TIR

End Mills – Square

2, 3, 4 Flute – Long Flute

GEL / GELM / AELM

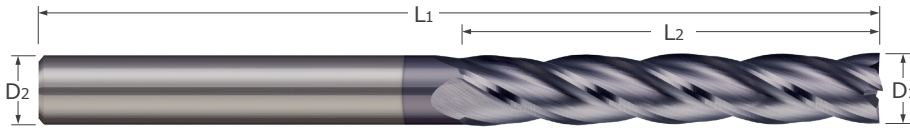

End Mills

- Long flutes for deep pocket milling and long length peripheral milling
- AITiN coating option for added lubricity and increased wear resistance in difficult-to-machine materials
- 30° helix ■ Center cutting
- Square profile
- Solid carbide ■ CNC ground in the USA

Cutter Diameter*		Length of Cut	Flutes	Shank Diameter	Overall Length	Uncoated		AITiN Coated	
D1 + .0000" - .0020" (h9) decimal equiv.	D2					L2 + .031" - .000" + .79 mm - .00 mm	L1	Tool #	Price
3 mm	.1181	15 mm	4	6 mm	75 mm	AELM-030-4	30.85	AELM-030-4X	36.10
4 mm	.1575	20 mm	2	6 mm	75 mm			AELM-040-2X	36.10
4 mm	.1575	25 mm	2	4 mm	75 mm			GELM-040-2X	27.05
6 mm	.2362	25 mm	3	6 mm	75 mm	GELM-060-3	34.35		
6 mm	.2362	25 mm	4	6 mm	75 mm	GELM-060-4	34.35		

D1 + .0000" - .0030" (h9) decimal equiv.		L2 + .031" - .000" + .79 mm - .00 mm	D2 (h6)	L1	Tool #	Price	Tool #	Price	
8 mm	.3150								30 mm
8 mm	.3150	40 mm	2	8 mm	100 mm	AELM-080-2	54.15		
8 mm	.3150	40 mm	4	8 mm	100 mm	AELM-080-4	54.15		
.3750	.3750	1.750	2	.3750	4.0	GEL-375-2	50.95		
10 mm	.3937	38 mm	3	10 mm	100 mm			GELM-100-3X	61.20
10 mm	.3937	50 mm	4	10 mm	120 mm	AELM-100-4	63.85		
12 mm	.4724	55 mm	4	12 mm	130 mm	AELM-120-4	89.40		
14 mm	.5512	60 mm	2	14 mm	140 mm			AELM-140-2X	151.85
16 mm	.6299	65 mm	4	16 mm	150 mm			AELM-160-4X	162.35
18 mm	.7087	75 mm	2	18 mm	150 mm			GELM-180-2X	212.25
18 mm	.7087	75 mm	3	18 mm	150 mm	GELM-180-3	191.90		
20 mm	.7874	75 mm	2	20 mm	150 mm			AELM-200-2X	286.90
25 mm	.9843	75 mm	2	25 mm	150 mm			GELM-250-2X	344.00
25 mm	.9843	75 mm	3	25 mm	150 mm	GELM-250-3	318.85		
25 mm	.9843	75 mm	4	25 mm	150 mm			GELM-250-4X	344.00

*.0005" / .013 mm max TIR

GLR / GLRM

End Mills – Square
2 & 4 Flute – Reduced Neck

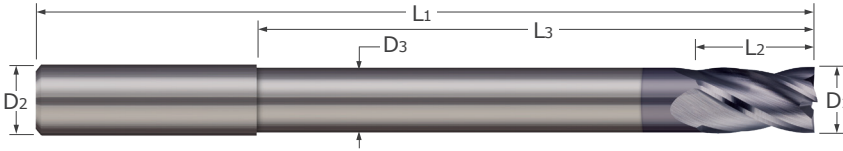

- Long reach design for deep cavities
- Reduced neck diameter to avoid heeling
- AlTiN coating option for added lubricity and increased wear resistance in difficult-to-machine materials
- 30° helix ■ Center cutting ■ Square profile
- Solid carbide ■ CNC ground in the USA

Cutter Diameter*			Length of Cut	Overall Reach	Neck Dia.	Flutes	Shank Dia.	Overall Length	Uncoated		AlTiN Coated	
D1 +.0000" -.0020" (h9) decimal equiv.	L2	L3	D3	D2 (h6)	L1	Tool #	Price	Tool #	Price			
3 mm	.1181	8 mm	30 mm	2.5 mm	2	6 mm	75 mm			GLRM-030-2X	42.75	
4 mm	.1575	8 mm	30 mm	3.5 mm	2	6 mm	75 mm			GLRM-040-2X	42.75	
4 mm	.1575	8 mm	30 mm	3.5 mm	4	6 mm	75 mm			GLRM-040-4X	42.75	
.1875	.1875	.375	2.00	.1675	2	.1875	3.0	GLR-187-2	36.55			
6 mm	.2362	12 mm	50 mm	5.5 mm	2	6 mm	100 mm	GLRM-060-2	39.45			

D1 +.0000" -.0030" (h9) decimal equiv.	L2	L3	D3	D2 (h6)	L1	Tool #	Price	Tool #	Price		
10 mm	.3937	18 mm	65 mm	9.5 mm	2	10 mm	120 mm	GLRM-100-2	60.30	GLRM-100-2X	70.80
16 mm	.6299	30 mm	100 mm	15 mm	2	16 mm	150 mm			GLRM-160-2X	186.90

*.0005" / .013 mm max TIR

End Mills – Square

2, 3, 4, 6 Flute – NC Tolerance

EMS / EMSM

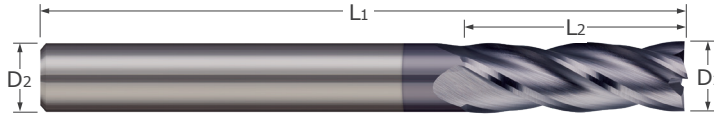

End Mills

- General purpose end mill with .001" plus tolerance on the cutting diameter
- Weldon flat featured on sizes 3/8" and larger
- 30° helix ■ Center cutting ■ Square profile
- AlTiN coating option for added lubricity and increased wear resistance in difficult-to-machine materials
- Solid carbide ■ CNC ground in the USA

Cutter Diameter*			Length of Cut	Flutes	Shank Diameter	Overall Length	Uncoated		AlTiN Coated	
D1 +.0010" -.0000"	D2		L2 +.030" -.000" +.78 mm -.00 mm	D2 (h6)	L1	Tool #	Price	Tool #	Price	
	+.03 mm -.00 mm	decimal equiv.								
.0312		.0312	.078	2	.1250	1.5	EMS-031-2	20.35		
.0312		.0312	.078	3	.1250	1.5	EMS-031-3	20.35	EMS-031-3X	23.00
.0312		.0312	.078	4	.1250	1.5	EMS-031-4	20.35	EMS-031-4X	23.00
.0625		.0625	.188	2	.1250	1.5	EMS-062-2	18.50	EMS-062-2X	21.15
.0625		.0625	.188	3	.1250	1.5	EMS-062-3	18.50	EMS-062-3X	21.15
.0625		.0625	.188	4	.1250	1.5	EMS-062-4	18.50	EMS-062-4X	21.15
.0938		.0938	.375	2	.1250	1.5			EMS-093-2X	21.15
.0938		.0938	.375	3	.1250	1.5	EMS-093-3	18.50	EMS-093-3X	21.15
.0938		.0938	.375	4	.1250	1.5	EMS-093-4	18.50	EMS-093-4X	21.15
3 mm		.1181	15 mm	2	3 mm	38 mm	EMSM-030-2	14.45		
3 mm		.1181	15 mm	4	3 mm	38 mm	EMSM-030-4	14.45		
.1250		.1250	.500	2	.1250	1.5	EMS-125-2	16.50	EMS-125-2X	19.15
.1250		.1250	.500	3	.1250	1.5	EMS-125-3	16.50	EMS-125-3X	19.15
.1250		.1250	.500	4	.1250	1.5	EMS-125-4	16.50	EMS-125-4X	19.15
.1562		.1562	.563	2	.1875	2.0	EMS-156-2	26.10		
.1562		.1562	.563	3	.1875	2.0	EMS-156-3	26.10		
.1562		.1562	.563	4	.1875	2.0	EMS-156-4	26.10	EMS-156-4X	29.10
4 mm		.1575	18 mm	2	4 mm	50 mm	EMSM-040-2	21.60	EMSM-040-2X	24.65
.1875		.1875	.625	2	.1875	2.0	EMS-187-2	26.10		
.1875		.1875	.625	4	.1875	2.0	EMS-187-4	26.10	EMS-187-4X	29.10
.2187		.2187	.625	3	.2500	2.5	EMS-218-3	32.75	EMS-218-3X	38.00
6 mm		.2362	18 mm	4	6 mm	57 mm	EMSM-060-4	27.25	EMSM-060-4X	32.50
.2500		.2500	.750	2	.2500	2.5	EMS-250-2	32.75		
.2500		.2500	.750	3	.2500	2.5	EMS-250-3	32.75	EMS-250-3X	38.00
.2500		.2500	.750	4	.2500	2.5	EMS-250-4	32.75	EMS-250-4X	38.00
.3125		.3125	.813	4	.3125	2.5	EMS-312-4	38.10	EMS-312-4X	45.40
8 mm		.3150	22 mm	3	8 mm	63 mm	EMSM-080-3	33.50		
.3750		.3750	.875	2	.3750	2.5	EMS-375-2	43.20	EMS-375-2X	50.45
.3750		.3750	.875	3	.3750	2.5	EMS-375-3	43.20	EMS-375-3X	50.45

*.0005" / .013 mm max TIR

Continued on next page



EMS / EMSM

End Mills – Square
2, 3, 4, 6 Flute – NC Tolerance (cont.)

Continued from previous page

Cutter Diameter*			Length of Cut	Flutes	Shank Diameter	Overall Length	Uncoated		AlTiN Coated	
D1 +.0010" -.0000"	+.03 mm -.00 mm	decimal equiv.	L2 +.030" -.000" +.78 mm -.00 mm		D2 (h6)	L1	Tool #	Price	Tool #	Price
.3750		.3750	.875	4	.3750	2.5	EMS-375-4	43.20	EMS-375-4X	50.45
	10 mm	.3937	25 mm	3	10 mm	72 mm	EMSM-100-3	39.55		
.4375		.4375	1.000	2	.4375	2.5	EMS-437-2	68.15		
	12 mm	.4724	30 mm	3	12 mm	83 mm	EMSM-120-3	63.00		
.5000		.5000	1.000	2	.5000	3.0	EMS-500-2	74.85	EMS-500-2X	83.35
.5000		.5000	1.000	3	.5000	3.0	EMS-500-3	74.85	EMS-500-3X	83.35
.5000		.5000	1.000	4	.5000	3.0	EMS-500-4	74.85	EMS-500-4X	83.35
.6250		.6250	1.250	4	.6250	3.5	EMS-625-4	132.40		
	16 mm	.6299	35 mm	3	16 mm	92 mm	EMSM-160-3	116.75		
.6875		.6875	1.375	3	.6875	4.0	EMS-687-3	163.10		
.7500		.7500	1.500	2	.7500	4.0	EMS-750-2	201.90		
.7500		.7500	1.500	4	.7500	4.0	EMS-750-4	201.90		
	20 mm	.7874	45 mm	4	20 mm	104 mm	EMSM-200-4	199.35		
1.0000		1.0000	2.500	3	1.0000	5.0	EMS-001-3	305.75		
1.0000		1.0000	2.500	6	1.0000	5.0	EMS-001-6	305.75		

*.0005" / .013 mm max TIR

End Mills

End Mills – Ball

2, 3, 4 Flute – Stub & Standard

**BMR / BMRM / BMS
BMSM / BEM / BEMM**

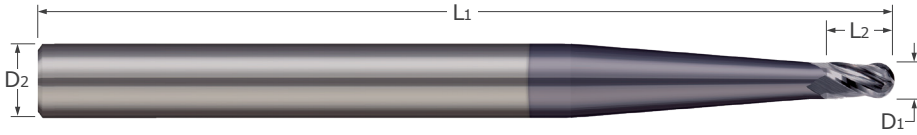

End Mills

- Designed for general purpose machining
- 30° helix ■ Center cutting
- Ball profile
- AlTiN coating option for added lubricity and increased wear resistance in difficult-to-machine materials
- Solid carbide
- CNC ground in the USA

Cutter Diameter*			Length of Cut	Flutes	Shank Diameter	Overall Length	Uncoated		AlTiN Coated	
D1 +.0005" -.0005"	+.00 mm -.02 mm	decimal equiv.	L2	D2 (h6)	L1	Tool #	Price	Tool #	Price	
										.0100
.0100	.0100	.0100	.030	2	.1250	1.5	BMR-010-2	45.55	BMR-010-2X	47.90
.0110	.0110	.0110	.033	2	.1250	1.5	BMR-011-2	41.35	BMR-011-2X	43.80
0.3 mm		.0118	0.5 mm	2	3 mm	38 mm	BMSM-003-2	32.85	BMSM-003-2X	35.35
.0120	.0120	.0120	.018	2	.1250	1.5			BMS-012-2X	41.85
.0120	.0120	.0120	.036	2	.1250	1.5	BMR-012-2	41.35	BMR-012-2X	43.80
.0130	.0130	.0130	.019	2	.1250	1.5	BMS-013-2	33.50	BMS-013-2X	36.00
.0130	.0130	.0130	.039	2	.1250	1.5			BMR-013-2X	37.65
.0140	.0140	.0140	.021	2	.1250	1.5	BMS-014-2	33.50	BMS-014-2X	36.00
.0140	.0140	.0140	.042	2	.1250	1.5	BMR-014-2	35.15	BMR-014-2X	37.65
.0150	.0150	.0150	.022	2	.1250	1.5	BMS-015-2	26.75	BMS-015-2X	29.30
.0150	.0150	.0150	.045	2	.1250	1.5	BMR-015-2	27.75	BMR-015-2X	30.30
0.4 mm		.0157	0.6 mm	2	3 mm	38 mm	BMSM-004-2	24.25	BMSM-004-2X	26.85
.0160	.0160	.0160	.024	2	.1250	1.5	BMS-016-2	26.75	BMS-016-2X	29.30
.0160	.0160	.0160	.048	2	.1250	1.5	BMR-016-2	27.75	BMR-016-2X	30.30
.0180	.0180	.0180	.027	2	.1250	1.5	BMS-018-2	26.75	BMS-018-2X	29.30
.0180	.0180	.0180	.054	2	.1250	1.5	BMR-018-2	27.75		
.0190	.0190	.0190	.028	2	.1250	1.5	BMS-019-2	26.75	BMS-019-2X	29.30
.0190	.0190	.0190	.057	2	.1250	1.5	BMR-019-2	27.75	BMR-019-2X	30.30
0.5 mm		.0197	0.8 mm	2	3 mm	38 mm	BMSM-005-2	22.40	BMSM-005-2X	25.00
0.5 mm		.0197	1.5 mm	2	4 mm	50 mm	BMRM-005-2	24.50	BMRM-005-2X	27.50
.0200	.0200	.0200	.030	2	.1250	1.5	BMS-020-2	24.60	BMS-020-2X	27.20
.0200	.0200	.0200	.060	2	.1250	1.5	BMR-020-2	25.80	BMR-020-2X	28.35
.0210	.0210	.0210	.063	2	.1250	1.5	BMR-021-2	25.80		
.0220	.0220	.0220	.033	2	.1250	1.5			BMS-022-2X	27.20
.0220	.0220	.0220	.066	2	.1250	1.5	BMR-022-2	25.80	BMR-022-2X	28.35
.0230	.0230	.0230	.034	2	.1250	1.5	BMS-023-2	24.60	BMS-023-2X	27.20
.0230	.0230	.0230	.069	2	.1250	1.5	BMR-023-2	25.80	BMR-023-2X	28.35
0.6 mm		.0236	0.9 mm	2	3 mm	38 mm	BMSM-006-2	22.40	BMSM-006-2X	25.00
0.6 mm		.0236	1.8 mm	2	4 mm	50 mm			BMRM-006-2X	27.50
.0240	.0240	.0240	.072	2	.1250	1.5	BMR-024-2	25.80	BMR-024-2X	28.35

*.0005" / .013 mm max TIR

Continued on next page

**BMR / BMRM / BMS
BMSM / BEM / BEMM**

End Mills – Ball
2, 3, 4 Flute – Stub & Standard (cont.)

Continued from previous page

Cutter Diameter*			Length of Cut	Flutes	Shank Diameter	Overall Length	Uncoated		AITIN Coated	
D1			L2		D2 (h6)	L1	Tool #	Price	Tool #	Price
+ .0005" - .0005"	+ .00 mm - .02 mm	decimal equiv.								
.0250		.0250	.037	2	.1250	1.5	BMS-025-2	24.60	BMS-025-2X	27.20
.0250		.0250	.075	2	.1250	1.5	BMR-025-2	25.80	BMR-025-2X	28.35
.0260		.0260	.039	2	.1250	1.5			BMS-026-2X	25.00
.0260		.0260	.078	2	.1250	1.5	BMR-026-2	23.50	BMR-026-2X	26.10
.0270		.0270	.081	2	.1250	1.5	BMR-027-2	23.50	BMR-027-2X	26.10
	0.7 mm	.0276	1.1 mm	2	3 mm	38 mm	BMSM-007-2	21.30	BMSM-007-2X	23.95
	0.7 mm	.0276	2.1 mm	2	4 mm	50 mm	BMRM-007-2	24.50	BMRM-007-2X	27.50
.0280		.0280	.042	2	.1250	1.5	BMS-028-2	22.40	BMS-028-2X	25.00
.0280		.0280	.084	2	.1250	1.5	BMR-028-2	23.50	BMR-028-2X	26.10
.0300		.0300	.045	2	.1250	1.5	BMS-030-2	22.40	BMS-030-2X	25.00
.0300		.0300	.090	2	.1250	1.5	BMR-030-2	23.50	BMR-030-2X	26.10
.0310		.0310	.047	2	.1250	1.5	BMS-031-2	22.40	BMS-031-2X	25.00
.0310		.0310	.093	2	.1250	1.5	BMR-031-2	23.50	BMR-031-2X	26.10

D1			L2		D2 (h6)	L1	Tool #	Price	Tool #	Price
+ .0000" - .0020"	+ .00 mm - .02 mm	decimal equiv.								
.0313		.0313	.078	2	.1250	1.5	BEM-031-02	19.50	BEM-031-02X	22.15
.0313		.0313	.078	3	.1250	1.5	BEM-031-03	19.50	BEM-031-03X	22.15
.0313		.0313	.078	4	.1250	1.5	BEM-031-04	19.50	BEM-031-04X	22.15
	0.8 mm	.0315	1.2 mm	2	3 mm	38 mm	BMSM-008-2	21.30	BMSM-008-2X	23.95
.0320		.0320	.048	2	.1250	1.5	BMS-032-2	22.40	BMS-032-2X	25.00
.0320		.0320	.096	2	.1250	1.5	BMR-032-2	23.50	BMR-032-2X	26.10
.0330		.0330	.050	2	.1250	1.5			BMS-033-2X	25.00
.0330		.0330	.099	2	.1250	1.5	BMR-033-2	23.50	BMR-033-2X	26.10
.0340		.0340	.051	2	.1250	1.5	BMS-034-2	22.40		
.0350		.0350	.053	2	.1250	1.5	BMS-035-2	22.40	BMS-035-2X	25.00
.0350		.0350	.105	2	.1250	1.5	BMR-035-2	23.50	BMR-035-2X	26.10
	0.9 mm	.0354	1.4 mm	2	3 mm	38 mm	BMSM-009-2	21.30	BMSM-009-2X	23.95
	0.9 mm	.0354	2.7 mm	2	4 mm	50 mm	BMRM-009-2	24.50	BMRM-009-2X	27.50
	1 mm	.0394	1.5 mm	2	3 mm	38 mm	BMSM-010-2	20.85	BMSM-010-2X	23.45
	1 mm	.0394	1.5 mm	4	3 mm	38 mm	BMSM-010-4	20.85	BMSM-010-4X	23.45
	1 mm	.0394	3 mm	2	4 mm	50 mm	BMRM-010-2	22.55	BMRM-010-2X	25.55
	1 mm	.0394	3 mm	4	4 mm	50 mm			BMRM-010-4X	25.55
.0400		.0400	.060	2	.1250	1.5	BMS-040-2	22.40	BMS-040-2X	25.00
.0400		.0400	.120	2	.1250	1.5	BMR-040-2	23.50	BMR-040-2X	26.10
	1.1 mm	.0433	3.3 mm	2	4 mm	50 mm			BMRM-011-2X	25.55
	1.1 mm	.0433	3.3 mm	4	4 mm	50 mm	BMRM-011-4	22.55	BMRM-011-4X	25.55
.0450		.0450	.135	2	.1250	1.5	BMR-045-2	23.50	BMR-045-2X	26.10
.0468		.0468	.109	2	.1250	1.5	BEM-046-02	19.50	BEM-046-02X	22.15
.0468		.0468	.109	3	.1250	1.5	BEM-046-03	19.50	BEM-046-03X	22.15
.0468		.0468	.109	4	.1250	1.5	BEM-046-04	19.50	BEM-046-04X	22.15
.0500		.0500	.075	2	.1250	1.5	BMS-050-2	22.40	BMS-050-2X	25.00
.0500		.0500	.150	2	.1250	1.5	BMR-050-2	23.50	BMR-050-2X	26.10

*.0005" / .013 mm max TIR

Continued on next page

End Mills – Ball

2, 3, 4 Flute – Stub & Standard (cont.)

**BMR / BMRM / BMS
BMSM / BEM / BEMM**

Continued from previous page

End Mills

Cutter Diameter*			Length of Cut	Flutes	Shank Diameter	Overall Length	Uncoated		AITIN Coated	
+.0000" -.0020"	+.00 mm -.02 mm	decimal equiv.	L2	D2 (h6)	L1	Tool #	Price	Tool #	Price	
										D1
1.4 mm	.0551		2.1 mm	2	3 mm	38 mm	BMSM-014-2	20.85	BMSM-014-2X	23.45
1.5 mm	.0591		2.3 mm	2	3 mm	38 mm	BMSM-015-2	20.85	BMSM-015-2X	23.45
1.5 mm	.0591		4.2 mm	2	4 mm	50 mm	BMRM-015-2	22.55	BMRM-015-2X	25.55
1.5 mm	.0591		4.2 mm	4	4 mm	50 mm	BMRM-015-4	22.55	BMRM-015-4X	25.55
.0625	.0625		.188	2	.1250	1.5	BEM-062-02	17.60	BEM-062-02X	20.25
.0625	.0625		.188	3	.1250	1.5	BEM-062-03	17.60	BEM-062-03X	20.25
.0625	.0625		.188	4	.1250	1.5	BEM-062-04	17.60	BEM-062-04X	20.25
1.6 mm	.0630		2.4 mm	2	3 mm	38 mm	BMSM-016-2	19.20	BMSM-016-2X	21.80
1.6 mm	.0630		4.8 mm	2	4 mm	50 mm	BMRM-016-2	22.55	BMRM-016-2X	25.55
1.7 mm	.0669		2.5 mm	4	3 mm	38 mm			BMSM-017-4X	21.80
1.8 mm	.0709		2.7 mm	2	3 mm	38 mm	BMSM-018-2	19.20	BMSM-018-2X	21.80
1.8 mm	.0709		5.3 mm	2	4 mm	50 mm			BMRM-018-2X	25.55
1.9 mm	.0748		2.8 mm	2	3 mm	38 mm			BMSM-019-2X	21.80
1.9 mm	.0748		2.8 mm	4	3 mm	38 mm	BMSM-019-4	19.20	BMSM-019-4X	21.80
.0781	.0781		.188	2	.1250	1.5	BEM-078-02	17.60	BEM-078-02X	20.25
.0781	.0781		.188	3	.1250	1.5	BEM-078-03	17.60	BEM-078-03X	20.25
.0781	.0781		.188	4	.1250	1.5	BEM-078-04	17.60	BEM-078-04X	20.25
2 mm	.0787		3 mm	2	3 mm	38 mm	BMSM-020-2	19.20	BMSM-020-2X	21.80
2 mm	.0787		6 mm	2	4 mm	50 mm	BMRM-020-2	22.55	BMRM-020-2X	25.55
2 mm	.0787		6 mm	4	4 mm	50 mm			BMRM-020-4X	25.55
.0937	.0937		.375	2	.1250	1.5	BEM-093-02	17.60	BEM-093-02X	20.25
.0937	.0937		.375	3	.1250	1.5	BEM-093-03	17.60	BEM-093-03X	20.25
.0937	.0937		.375	4	.1250	1.5	BEM-093-04	17.60	BEM-093-04X	20.25
2.5 mm	.0984		3.8 mm	2	3 mm	38 mm	BMSM-025-2	19.20	BMSM-025-2X	21.80
.1093	.1093		.375	2	.1250	1.5	BEM-109-02	17.60		
3 mm	.1181		15 mm	2	3 mm	38 mm	BEMM-030-2	14.45		
3 mm	.1181		15 mm	3	3 mm	38 mm	BEMM-030-3	14.45	BEMM-030-3X	17.10
3 mm	.1181		15 mm	4	3 mm	38 mm	BEMM-030-4	14.45	BEMM-030-4X	17.10
3 mm	.1181		9 mm	2	4 mm	50 mm	BMRM-030-2	22.55	BMRM-030-2X	25.55
3 mm	.1181		9 mm	4	4 mm	50 mm			BMRM-030-4X	25.55
.1250	.1250		.500	2	.1250	1.5	BEM-125-02	15.75	BEM-125-02X	18.45
.1250	.1250		.500	3	.1250	1.5	BEM-125-03	15.75	BEM-125-03X	18.45
.1250	.1250		.500	4	.1250	1.5	BEM-125-04	15.75	BEM-125-04X	18.45
3.5 mm	.1378		10.5 mm	2	4 mm	50 mm			BMRM-035-2X	25.55
.1562	.1562		.563	2	.1875	2.0	BEM-156-02	25.00	BEM-156-02X	28.05
.1562	.1562		.563	3	.1875	2.0	BEM-156-03	25.00	BEM-156-03X	28.05
.1562	.1562		.563	4	.1875	2.0	BEM-156-04	25.00	BEM-156-04X	28.05
4 mm	.1575		18 mm	2	4 mm	50 mm	BEMM-040-2	21.60	BEMM-040-2X	24.65
4 mm	.1575		18 mm	3	4 mm	50 mm	BEMM-040-3	21.60	BEMM-040-3X	24.65
4 mm	.1575		18 mm	4	4 mm	50 mm	BEMM-040-4	21.60	BEMM-040-4X	24.65

*.0005" / .013 mm max TIR

Continued on next page

**BMR / BMRM / BMS
BMSM / BEM / BEMM**

End Mills – Ball
2, 3, 4 Flute – Stub & Standard (cont.)

Continued from previous page

Cutter Diameter*			Length of Cut	Flutes	Shank Diameter	Overall Length	Uncoated		AlTiN Coated	
D1			L2		D2 (h6)	L1	Tool #	Price	Tool #	Price
+ .0000" - .0020"	+ .00 mm - .02 mm	decimal equiv.								
.1719		.1719	.625	2	.1875	2.0			BEM-171-02X	28.05
.1875		.1875	.625	2	.1875	2.0	BEM-187-02	25.00	BEM-187-02X	28.05
.1875		.1875	.625	3	.1875	2.0	BEM-187-03	25.00	BEM-187-03X	28.05
.1875		.1875	.625	4	.1875	2.0	BEM-187-04	25.00	BEM-187-04X	28.05
.2031		.2031	.625	3	.2500	2.5			BEM-203-03X	36.55
.2187		.2187	.625	2	.2500	2.5	BEM-218-02	31.40	BEM-218-02X	36.55
.2187		.2187	.625	4	.2500	2.5	BEM-218-04	31.40	BEM-218-04X	36.55
.2343		.2343	.750	3	.2500	2.5	BEM-234-03	31.40		
	6 mm	.2362	18 mm	4	6 mm	57 mm	BEMM-060-4	27.25	BEMM-060-4X	32.50
.2500		.2500	.750	2	.2500	2.5	BEM-250-02	31.40	BEM-250-02X	36.55
.2500		.2500	.750	3	.2500	2.5	BEM-250-03	31.40	BEM-250-03X	36.55
.2500		.2500	.750	4	.2500	2.5	BEM-250-04	31.40	BEM-250-04X	36.55
.2812		.2812	.750	4	.3125	2.5	BEM-281-04	36.50	BEM-281-04X	43.85
.3125		.3125	.813	2	.3125	2.5	BEM-312-02	36.50	BEM-312-02X	43.85
.3125		.3125	.813	4	.3125	2.5	BEM-312-04	36.50	BEM-312-04X	43.85
	8 mm	.3150	22 mm	2	8 mm	63 mm	BEMM-080-2	33.50	BEMM-080-2X	40.85
.3750		.3750	.875	2	.3750	2.5	BEM-375-02	41.45	BEM-375-02X	48.70
.3750		.3750	.875	3	.3750	2.5	BEM-375-03	41.45	BEM-375-03X	48.70
.3750		.3750	.875	4	.3750	2.5	BEM-375-04	41.45	BEM-375-04X	48.70
	10 mm	.3937	25 mm	2	10 mm	72 mm	BEMM-100-2	39.55	BEMM-100-2X	46.80
	10 mm	.3937	25 mm	3	10 mm	72 mm	BEMM-100-3	39.55	BEMM-100-3X	46.80
	10 mm	.3937	25 mm	4	10 mm	72 mm	BEMM-100-4	39.55	BEMM-100-4X	46.80
.4370		.4370	1.000	2	.4375	2.5			BEM-437-02X	74.75
	12 mm	.4724	30 mm	3	12 mm	83 mm			BEMM-120-3X	74.00
	12 mm	.4724	30 mm	4	12 mm	83 mm	BEMM-120-4	63.00	BEMM-120-4X	74.00
.5000		.5000	1.000	3	.5000	3.0	BEM-500-03	71.75	BEM-500-03X	80.30
.5000		.5000	1.000	4	.5000	3.0	BEM-500-04	71.75	BEM-500-04X	80.30
.6250		.6250	1.250	4	.6250	3.5	BEM-625-04	126.90	BEM-625-04X	139.60
	16 mm	.6299	35 mm	3	16 mm	92 mm			BEMM-160-3X	129.60
.6875		.6875	1.375	2	.7500	4.0	BEM-687-02	156.20		
.6875		.6875	1.375	3	.7500	4.0	BEM-687-03	156.20		
.6875		.6875	1.375	4	.7500	4.0	BEM-687-04	156.20		
	18 mm	.7087	45 mm	2	18 mm	92 mm			BEMM-180-2X	171.45
.7500		.7500	1.500	4	.7500	4.0			BEM-750-04X	207.80
	20 mm	.7874	45 mm	4	20 mm	104 mm	BEMM-200-4	199.35		
.8750		.8750	1.500	2	.8750	4.0	BEM-875-02	268.15		

*.0005" / .013 mm max TIR

End Mills – Ball

2, 3, 4 Flute – Long Flute

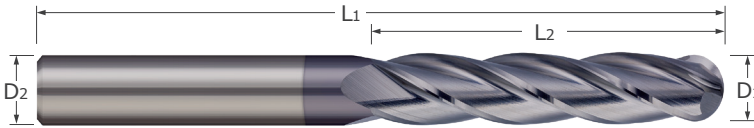

End Mills

- Long reach for deep pocket milling and long length peripheral milling
- 30° helix ■ Center cutting
- Ball profile
- AlTiN coating option for added lubricity and increased wear resistance in difficult-to-machine materials
- Solid carbide
- CNC ground in the USA

Cutter Diameter*	Length of Cut	Flutes	Shank Diameter	Overall Length	Uncoated		AlTiN Coated	
					Tool #	Price	Tool #	Price
D ₁ (h9)	L ₂ $\begin{matrix} +.79 \text{ mm} \\ -.00 \text{ mm} \end{matrix}$		D ₂ (h6)	L ₁				
10 mm	38 mm	4	10 mm	100 mm	BELM-100-4	57.55		
12 mm	50 mm	3	12 mm	100 mm			BELM-120-3X	94.80
14 mm	75 mm	4	14 mm	150 mm	BELM-140-4	125.30		
18 mm	75 mm	4	18 mm	150 mm	BELM-180-4	210.95		
20 mm	75 mm	2	20 mm	150 mm	BELM-200-2	285.25		
25 mm	75 mm	2	25 mm	150 mm			BELM-250-2X	359.85
25 mm	75 mm	4	25 mm	150 mm	BELM-250-4	334.80	BELM-250-4X	359.85

*.013 mm max TIR

**BLR / BLRM
SFBM / MMBM**

End Mills – Ball
2, 3, 4 Flute – Reduced Neck

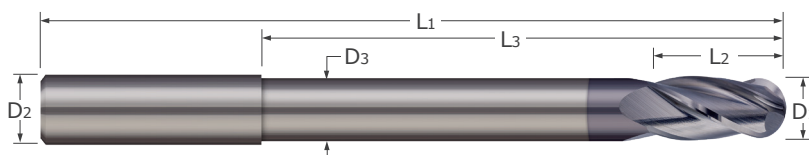

- Long reach for deep pocket milling
- SFBM and MMBM manufactured to improved cutter diameter tolerance (h8) for mold making
- 30° helix ■ Center cutting
- Ball profile
- AlTiN coating option for added lubricity and increased wear resistance in difficult-to-machine materials
- Solid carbide
- CNC ground in the USA

Cutter Diameter*		Length of Cut	Overall Reach	Neck Dia.	Flutes	Shank Dia.	Overall Length	Uncoated		AlTiN Coated	
D1	D2	L2	L3	D3		D2 (h6)	L1	Tool #	Price	Tool #	Price
+ .0000" - .0020" (h6)	decimal equiv.	+ .015" - .000" + .38 mm - .00 mm	+ .015" - .015" + .38 mm - .38 mm								
0.2 mm	.0078	0.3 mm	0.3 mm	-	2	6 mm	57 mm	SFBM-002-0	69.85	SFBM-002-0X	74.75
0.3 mm	.0118	0.3 mm	3.0 mm	0.28 mm	2	4 mm	50 mm	MMBM-003-3	53.15	MMBM-003-3X	55.90
0.3 mm	.0118	0.4 mm	0.4 mm	0.4 mm	2	6 mm	57 mm			SFBM-003-0X	67.20
0.3 mm	.0118	0.4 mm	1.0 mm	0.25 mm	2	6 mm	57 mm	SFBM-003-1	61.65		
0.4 mm	.0157	0.4 mm	3.0 mm	0.38 mm	2	4 mm	50 mm	MMBM-004-3	45.70	MMBM-004-3X	48.55
0.4 mm	.0157	0.4 mm	8.0 mm	0.38 mm	2	4 mm	50 mm	MMBM-004-8	45.70	MMBM-004-8X	48.55
0.4 mm	.0157	0.5 mm	1.2 mm	0.35 mm	2	6 mm	57 mm			SFBM-004-1X	65.60
0.5 mm	.0197	0.5 mm	5.0 mm	0.48 mm	2	4 mm	50 mm	MMBM-005-5	40.30	MMBM-005-5X	43.15
0.5 mm	.0197	0.5 mm	10.0 mm	0.48 mm	2	4 mm	50 mm	MMBM-005-10	40.30	MMBM-005-10X	43.15
0.5 mm	.0197	0.6 mm	1.6 mm	0.45 mm	2	6 mm	57 mm			SFBM-005-1X	62.75
0.6 mm	.0236	0.6 mm	12.0 mm	0.58 mm	2	4 mm	50 mm			MMBM-006-12X	43.15
0.6 mm	.0236	0.6 mm	5.0 mm	0.58 mm	2	4 mm	50 mm	MMBM-006-5	40.30	MMBM-006-5X	43.15
0.7 mm	.0276	0.7 mm	5.0 mm	0.68 mm	2	4 mm	50 mm	MMBM-007-5	40.30		
0.8 mm	.0315	0.8 mm	5.0 mm	0.78 mm	2	4 mm	50 mm	MMBM-008-5	34.60	MMBM-008-5X	37.50
0.8 mm	.0315	0.8 mm	5.2 mm	0.75 mm	2	6 mm	57 mm			SFBM-008-5X	59.70
0.8 mm	.0315	0.8 mm	8.0 mm	0.75 mm	2	6 mm	57 mm			SFBM-008-8X	64.60
0.8 mm	.0315	0.8 mm	10.0 mm	0.78 mm	2	4 mm	50 mm	MMBM-008-10	34.60		
1.0 mm	.0394	1.3 mm	3.3 mm	0.95 mm	2	6 mm	57 mm			SFBM-010-3X	56.80
1.0 mm	.0394	1.0 mm	6.0 mm	0.95 mm	2	6 mm	57 mm	MMBM-010-6	37.95	MMBM-010-6X	43.10
1.0 mm	.0394	1.0 mm	11.0 mm	0.95 mm	2	6 mm	57 mm	MMBM-010-11	37.95	MMBM-010-11X	43.10
1.0 mm	.0394	1.0 mm	12.0 mm	0.95 mm	2	6 mm	57 mm			MMBM-010-12X	43.10
1.0 mm	.0394	1.0 mm	15.0 mm	0.95 mm	2	6 mm	57 mm			MMBM-010-15X	43.10
1.0 mm	.0394	1.0 mm	20.0 mm	0.95 mm	2	6 mm	57 mm	MMBM-010-20	37.95	MMBM-010-20X	43.10
1.2 mm	.0472	1.2 mm	7.0 mm	1.15 mm	2	6 mm	57 mm			MMBM-012-7X	43.10
1.2 mm	.0472	1.2 mm	15.0 mm	1.15 mm	2	6 mm	57 mm	MMBM-012-15	37.95	MMBM-012-15X	43.10
1.2 mm	.0472	1.2 mm	20.0 mm	1.15 mm	2	6 mm	57 mm	MMBM-012-20	37.95		

*.0005" / .013 mm max TIR. SFBM and MMBM tools held to h8 tolerance

Continued on next page

End Mills – Ball 2, 3, 4 Flute – Reduced Neck (cont.)

**BLR / BLRM
SFBM / MMBM**

Continued from previous page

End Mills

Cutter Diameter*			Length of Cut	Overall Reach	Neck Dia.	Flutes	Shank Dia.	Overall Length	Uncoated		AlTiN Coated	
D1 + .0000" - .0020" (h6)	decimal equiv.	L2	L3	D3	D2 (h6)	L1	Tool #	Price	Tool #	Price		
											+ .015" - .000" + .38 mm - .00 mm	+ .015" - .015" + .38 mm - .38 mm
1.5 mm	.0591	1.5 mm	7.0 mm	1.45 mm	2	6 mm	57 mm	MMBM-015-7	37.95	MMBM-015-7X	43.10	
1.5 mm	.0591	1.5 mm	9.5 mm	1.45 mm	2	6 mm	57 mm	SFBM-015-9	49.25	SFBM-015-9X	54.25	
1.5 mm	.0591	1.5 mm	15.0 mm	1.45 mm	2	6 mm	57 mm	MMBM-015-15	37.95	MMBM-015-15X	43.10	
1.5 mm	.0591	1.5 mm	20.0 mm	1.45 mm	2	6 mm	57 mm			MMBM-015-20X	43.10	
2.0 mm	.0787	2.0 mm	7.0 mm	1.9 mm	2	6 mm	57 mm	MMBM-020-7	37.95	MMBM-020-7X	43.10	
2.0 mm	.0787	2.0 mm	15.0 mm	1.9 mm	2	6 mm	57 mm	MMBM-020-15	37.95	MMBM-020-15X	43.10	
2.0 mm	.0787	2.0 mm	20.0 mm	1.9 mm	2	6 mm	57 mm	MMBM-020-20	37.95	MMBM-020-20X	43.10	
2.0 mm	.0787	2.5 mm	9.5 mm	1.95 mm	2	6 mm	57 mm	SFBM-020-9	47.35	SFBM-020-9X	52.40	
2.0 mm	.0787	5.0 mm	15.0 mm	1.5 mm	4	6 mm	57 mm			BLRM-020-4X	37.40	
3.0 mm	.1181	3.0 mm	12.0 mm	2.9 mm	2	6 mm	57 mm			MMBM-030-12X	43.10	
3.0 mm	.1181	3.0 mm	15.0 mm	2.9 mm	2	6 mm	57 mm	MMBM-030-15	37.95	MMBM-030-15X	43.10	
3.0 mm	.1181	4.0 mm	8.0 mm	2.9 mm	2	6 mm	57 mm	SFBM-030-8	42.35	SFBM-030-8X	47.50	
3.0 mm	.1181	4.0 mm	15.0 mm	2.9 mm	2	6 mm	57 mm	SFBM-030-15	45.40	SFBM-030-15X	50.50	
3.0 mm	.1181	8.0 mm	30.0 mm	2.5 mm	2	6 mm	75 mm	BLRM-030-2	34.10	BLRM-030-2X	39.25	
3.0 mm	.1181	8.0 mm	30.0 mm	2.5 mm	4	6 mm	75 mm	BLRM-030-4	34.10	BLRM-030-4X	39.25	
4.0 mm	.1575	4.0 mm	15.0 mm	3.8 mm	2	6 mm	57 mm	MMBM-040-15	37.95	MMBM-040-15X	43.10	
4.0 mm	.1575	5.0 mm	10.0 mm	3.9 mm	2	6 mm	57 mm			SFBM-040-10X	47.50	
4.0 mm	.1575	8.0 mm	30.0 mm	3.5 mm	2	6 mm	75 mm	BLRM-040-2	34.10	BLRM-040-2X	39.25	
4.0 mm	.1575	8.0 mm	30.0 mm	3.5 mm	3	6 mm	75 mm	BLRM-040-3	34.10			
4.0 mm	.1575	8.0 mm	30.0 mm	3.5 mm	4	6 mm	75 mm	BLRM-040-4	34.10	BLRM-040-4X	39.25	

D1 + .0000" - .0030" (h6)	decimal equiv.	L2	L3	D3	D2 (h6)	L1	Tool #	Price	Tool #	Price	
											+ .015" - .000" + .38 mm - .00 mm
.1875	.1875	.375	2.00	.1675	2	.1875	3.0		BLR-187-2X	44.30	
.1875	.1875	.375	2.00	.1675	4	.1875	3.0		BLR-187-4X	44.30	
5 mm	.1969	6.0 mm	11.0 mm	4.9 mm	2	6 mm	57 mm		SFBM-050-11X	45.30	
6 mm	.2362	7.5 mm	12.5 mm	5.9 mm	2	6 mm	57 mm	SFBM-060-12	39.60	SFBM-060-12X	44.75
6 mm	.2362	12.0 mm	50.0 mm	5.5 mm	2	6 mm	100 mm	BLRM-060-2	43.75		
6 mm	.2362	12.0 mm	50.0 mm	5.5 mm	4	6 mm	100 mm	BLRM-060-4	43.75	BLRM-060-4X	48.80
6 mm	.2362	12.0 mm	50.0 mm	12.0 mm	3	6 mm	100 mm			BLRM-060-3X	48.80
.2500	.2500	.500	2.50	.2300	2	.2500	4.0	BLR-250-2	48.50	BLR-250-2X	53.55
.2500	.2500	.500	2.50	.2300	4	.2500	4.0	BLR-250-4	48.50	BLR-250-4X	53.55
8 mm	.3150	14.0 mm	50.0 mm	7.5 mm	2	8 mm	100 mm	BLRM-080-2	59.70	BLRM-080-2X	65.60
8 mm	.3150	14.0 mm	50.0 mm	7.5 mm	4	8 mm	100 mm			BLRM-080-4X	65.60
.3750	.3750	.750	2.75	.3550	4	.3750	4.0	BLR-375-4	64.35	BLR-375-4X	73.65
10 mm	.3937	18.0 mm	65.0 mm	9.5 mm	4	10 mm	120 mm	BLRM-100-4	67.05	BLRM-100-4X	77.45
.4375	.4375	1.000	4.50	.4175	2	.4375	6.0	BLR-437-2	97.10		
12 mm	.4724	22.0 mm	80.0 mm	11.5 mm	2	12 mm	130 mm	BLRM-120-2	93.90		
12 mm	.4724	22.0 mm	80.0 mm	11.5 mm	3	12 mm	130 mm			BLRM-120-3X	106.55
12 mm	.4724	22.0 mm	80.0 mm	11.5 mm	4	12 mm	130 mm			BLRM-120-4X	106.55
.5000	.5000	1.000	4.50	.4800	2	.5000	6.0	BLR-500-2	111.05	BLR-500-2X	125.75
.5000	.5000	1.000	4.50	.4800	4	.5000	6.0	BLR-500-4	111.05	BLR-500-4X	125.75

*.0005" / .013 mm max TIR. SFBM and MMBM tools held to h8 tolerance

Continued on next page

**BLR / BLRM
SFBM / MMBM**

End Mills – Ball
2, 3, 4 Flute – Reduced Neck (cont.)

Continued from previous page

Cutter Diameter*		Length of Cut	Overall Reach	Neck Dia.	Flutes	Shank Dia.	Overall Length	Uncoated		AITIN Coated	
D1 +.0000" -.0030" (h6)	decimal equiv.	L2 +.015" -.000" +.38 mm -.00 mm	L3 +.030" -.030" +.38 mm -.38 mm	D3	D2 (h6)	L1	Tool #	Price	Tool #	Price	
.6250	.6250	1.250	4.50	.6050	2	.6250	6.0	BLR-625-2	196.75		
16 mm	.6299	30.0 mm	100.0 mm	15.5 mm	4	16 mm	150 mm	BLRM-160-4	165.85		
.7500	.7500	1.500	4.50	.7300	2	.7500	6.0	BLR-750-2	298.80		
20 mm	.7874	38.0 mm	100.0 mm	19.5 mm	3	20 mm	150 mm	BLRM-200-3	271.30	BLRM-200-3X	295.90
20 mm	.7874	38.0 mm	100.0 mm	19.5 mm	4	20 mm	150 mm	BLRM-200-4	271.30		
20 mm	.7874	38.0 mm	100.0 mm	38.0 mm	2	20 mm	150 mm			BLRM-200-2X	295.90

*.0005" / .013 mm max TIR. SFBM and MMBM tools held to h8 tolerance

End Mills



**Check Real-Time Availability
of Up to 50 Tools at Once**

On Micro100.com/check-stock

End Mills – Corner Radius

2, 3, 4 Flute

AECM / GEC

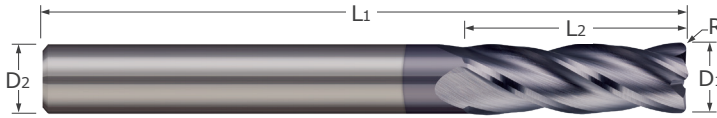

End Mills

- Designed for general purpose machining
- 30° helix ■ Center cutting
- Corner radius profile
- AlTiN coating option for added lubricity and increased wear resistance in difficult-to-machine materials
- Solid carbide
- CNC ground in the USA

Cutter Diameter*			Length of Cut	Corner Radius	Flutes	Shank Diameter	Overall Length	Uncoated		AlTiN Coated	
D1	(h9)	decimal equiv.	L2	R		D2 (h6)	L1	Tool #	Price	Tool #	Price
+ .0000"			+ .031"	+ .0000"							
- .0020"			- .000"	- .0005"							
			+ .79 mm	+ .000 mm							
			- .00 mm	- .013 mm							
.0312	.0312	.0312	.078	.005	2	.1250	1.5	GEC-031-2-005	19.50	GEC-031-2-005X	22.15
.0312	.0312	.0312	.078	.005	3	.1250	1.5	GEC-031-3-005	19.50	GEC-031-3-005X	22.15
.0312	.0312	.0312	.078	.005	4	.1250	1.5			GEC-031-4-005X	22.15
1 mm	.0394	.0394	4 mm	0.1 mm	4	4 mm	50 mm			AECM-0101-4X	24.55
1 mm	.0394	.0394	4 mm	0.2 mm	4	4 mm	50 mm			AECM-0102-4X	24.55
.0625	.0625	.0625	.188	.005	2	.1250	1.5	GEC-062-2-005	17.60		
.0625	.0625	.0625	.188	.005	3	.1250	1.5			GEC-062-3-005X	20.25
.0625	.0625	.0625	.188	.005	4	.1250	1.5	GEC-062-4-005	17.60	GEC-062-4-005X	20.25
.0625	.0625	.0625	.188	.010	3	.1250	1.5	GEC-062-3-010	17.60	GEC-062-3-010X	20.25
.0625	.0625	.0625	.188	.010	4	.1250	1.5	GEC-062-4-010	17.60	GEC-062-4-010X	20.25
2 mm	.0787	.0787	5 mm	0.2 mm	4	4 mm	50 mm			AECM-0202-4X	24.55
2 mm	.0787	.0787	5 mm	0.5 mm	4	4 mm	50 mm			AECM-0205-4X	24.55
.0938	.0938	.0938	.375	.005	4	.1250	1.5			GEC-093-4-005X	20.25
.0938	.0938	.0938	.375	.010	2	.1250	1.5	GEC-093-2-010	17.60	GEC-093-2-010X	20.25
.0938	.0938	.0938	.375	.010	3	.1250	1.5	GEC-093-3-010	17.60	GEC-093-3-010X	20.25
.0938	.0938	.0938	.375	.010	4	.1250	1.5			GEC-093-4-010X	20.25
3 mm	.1181	.1181	8 mm	0.5 mm	4	6 mm	57 mm			AECM-0305-4X	32.45
.1250	.1250	.1250	.500	.010	3	.1250	1.5	GEC-125-3-010	17.60	GEC-125-3-010X	20.25
.1250	.1250	.1250	.500	.010	4	.1250	1.5	GEC-125-4-010	17.60	GEC-125-4-010X	20.25
.1250	.1250	.1250	.500	.020	2	.1250	1.5			GEC-125-2-020X	20.25
.1250	.1250	.1250	.500	.020	3	.1250	1.5	GEC-125-3-020	17.60	GEC-125-3-020X	20.25
.1250	.1250	.1250	.500	.020	4	.1250	1.5	GEC-125-4-020	17.60	GEC-125-4-020X	20.25
4 mm	.1575	.1575	11 mm	0.2 mm	4	6 mm	57 mm			AECM-0402-4X	32.45
4 mm	.1575	.1575	11 mm	0.5 mm	4	6 mm	57 mm			AECM-0405-4X	32.45
.1875	.1875	.1875	.625	.010	4	.1875	2.0			GEC-187-4-010X	28.05
.1875	.1875	.1875	.625	.020	3	.1875	2.0	GEC-187-3-020	25.00	GEC-187-3-020X	28.05
.1875	.1875	.1875	.625	.030	2	.1875	2.0	GEC-187-2-030	25.00		
.1875	.1875	.1875	.625	.030	3	.1875	2.0	GEC-187-3-030	25.00	GEC-187-3-030X	28.05
.1875	.1875	.1875	.625	.030	4	.1875	2.0			GEC-187-4-030X	28.05
6 mm	.2362	.2362	16 mm	0.3 mm	4	6 mm	57 mm	AECM-0603-4	27.20	AECM-0603-4X	32.45
6 mm	.2362	.2362	16 mm	0.5 mm	4	6 mm	57 mm	AECM-0605-4	27.20	AECM-0605-4X	32.45
6 mm	.2362	.2362	16 mm	1.0 mm	4	6 mm	57 mm			AECM-0610-4X	32.45

*.0005" / .013 mm max TIR

Continued on next page

AECM / GEC

End Mills – Corner Radius

2, 3, 4 Flute (cont.)

Continued from previous page

Cutter Diameter*		Length of Cut	Corner Radius	Flutes	Shank Diameter	Overall Length	Uncoated		AITIN Coated	
D1 +.0000" -.0020" (h9) decimal equiv.		L2 +.031" -.000" +.79 mm -.00 mm	R +.0000" -.0005" +.000 mm -.013 mm		D2 (h6)	L1	Tool #	Price	Tool #	Price
.2500	.2500	.750	.010	2	.2500	2.5			GEC-250-2-010X	36.55
.2500	.2500	.750	.010	4	.2500	2.5	GEC-250-4-010	31.40	GEC-250-4-010X	36.55
.2500	.2500	.750	.020	2	.2500	2.5	GEC-250-2-020	31.40		
.2500	.2500	.750	.020	3	.2500	2.5			GEC-250-3-020X	36.55
.2500	.2500	.750	.020	4	.2500	2.5			GEC-250-4-020X	36.55
.2500	.2500	.750	.030	3	.2500	2.5	GEC-250-3-030	31.40	GEC-250-3-030X	36.55
.2500	.2500	.750	.030	4	.2500	2.5	GEC-250-4-030	31.40	GEC-250-4-030X	36.55
.3125	.3125	.813	.010	2	.3125	2.5	GEC-312-2-010	36.50	GEC-312-2-010X	43.85
.3125	.3125	.813	.010	4	.3125	2.5	GEC-312-4-010	36.50	GEC-312-4-010X	43.85
.3125	.3125	.813	.020	2	.3125	2.5	GEC-312-2-020	36.50		
8 mm	.3150	22 mm	1.0 mm	2	8 mm	63 mm	AECM-0810-2	33.50		
.3750	.3750	.875	.010	2	.3750	2.5	GEC-375-2-010	41.45	GEC-375-2-010X	48.70
.3750	.3750	.875	.010	4	.3750	2.5	GEC-375-4-010	41.45	GEC-375-4-010X	48.70
.3750	.3750	.875	.030	3	.3750	2.5	GEC-375-3-030	41.45	GEC-375-3-030X	48.70
.3750	.3750	.875	.030	4	.3750	2.5			GEC-375-4-030X	48.70
10 mm	.3937	25 mm	0.5 mm	4	10 mm	72 mm	AECM-1005-4	39.55		
10 mm	.3937	25 mm	1.5 mm	4	10 mm	72 mm	AECM-1015-4	39.55		
12 mm	.4724	30 mm	0.5 mm	4	12 mm	83 mm	AECM-1205-4	63.10		
12 mm	.4724	30 mm	1.5 mm	2	12 mm	83 mm			AECM-1215-2X	74.10
12 mm	.4724	30 mm	1.5 mm	3	12 mm	83 mm			AECM-1215-3X	74.10
12 mm	.4724	30 mm	1.5 mm	4	12 mm	83 mm	AECM-1215-4	63.10	AECM-1215-4X	74.10
.5000	.5000	1.000	.010	4	.5000	3.0	GEC-500-4-010	71.75	GEC-500-4-010X	80.30
.5000	.5000	1.000	.030	3	.5000	3.0	GEC-500-3-030	71.75		
.6250	.6250	1.250	.020	2	.6250	3.5	GEC-625-2-020	126.90		
.6250	.6250	1.250	.030	3	.6250	3.5	GEC-625-3-030	126.90		
.6250	.6250	1.250	.060	2	.6250	3.5	GEC-625-2-060	126.90		
.6250	.6250	1.250	.090	2	.6250	3.5	GEC-625-2-090	126.90		
.6250	.6250	1.250	.090	3	.6250	3.5	GEC-625-3-090	126.90		
.7500	.7500	1.500	.020	2	.7500	4.0	GEC-750-2-020	193.55		
1.0000	1.0000	1.500	.020	2	1.0000	4.0	GEC-001-2-020	293.15		
1.0000	1.0000	1.500	.030	2	1.0000	4.0	GEC-001-2-030	293.15		
1.0000	1.0000	1.500	.060	2	1.0000	4.0	GEC-001-2-060	293.15		
1.0000	1.0000	1.500	.090	2	1.0000	4.0	GEC-001-2-090	293.15		

*.0005" / .013 mm max TIR

End Mills – Corner Radius

2 Flute – Reduced Neck

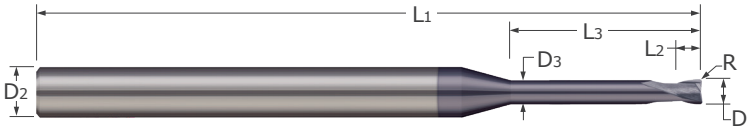

End Mills

- Designed for mold making applications
- Manufactured to tighter cutter diameter tolerance (h8) for mold making applications
- Long reach for deep pocket milling
- Reduced neck diameter to avoid heeling
- Corner radius profile
- 30° helix ■ Center cutting
- AlTiN coating option for added lubricity and increased wear resistance in difficult-to-machine materials
- Solid carbide ■ CNC ground in the USA

Cutter Diameter*	Length of Cut	Corner Radius	Overall Reach	Neck Diameter	Shank Diameter	Overall Length	Uncoated		AlTiN Coated	
							Tool #	Price	Tool #	Price
D1 (h8)	L2 ^{+0.38mm} / _{-0.00mm}	R ^{+0.00mm} / _{-0.013mm}	L3 ^{+0.25mm} / _{-0.00mm}	D3 ^{+0.00mm} / _{-0.13mm}	D2 (h6)	L1				
0.8 mm	0.8 mm	0.1 mm	10 mm	0.78 mm	4 mm	50 mm	MMRM-008-10	31.20	MMRM-008-10X	34.15
0.8 mm	0.8 mm	0.1 mm	16 mm	0.78 mm	4 mm	50 mm	MMRM-008-16	31.20		
1 mm	1 mm	0.1 mm	8 mm	0.95 mm	6 mm	57 mm	MMRM-010-8	34.50		
1.5 mm	1.5 mm	0.15 mm	7 mm	1.45 mm	6 mm	57 mm	MMRM-015-7	34.50		
1.5 mm	1.5 mm	0.15 mm	15 mm	1.45 mm	6 mm	57 mm	MMRM-015-15	34.50		
1.5 mm	1.5 mm	0.15 mm	25 mm	1.45 mm	6 mm	72 mm	MMRM-015-25	34.50	MMRM-015-25X	39.65
3 mm	3 mm	0.25 mm	8 mm	2.9 mm	6 mm	57 mm	MMRM-030-8	34.50		
4 mm	4 mm	0.25 mm	9 mm	3.8 mm	6 mm	57 mm	MMRM-040-9	34.50		
4 mm	4 mm	0.25 mm	15 mm	3.8 mm	6 mm	57 mm			MMRM-040-15X	39.65
5 mm	5 mm	0.50 mm	30 mm	4.8 mm	6 mm	72 mm	MMRM-050-30	34.50		
6 mm	6 mm	1 mm	11 mm	5.8 mm	6 mm	57 mm	MMRM-060-11	34.50	MMRM-060-11X	39.65
10 mm	10 mm	1 mm	25 mm	9.8 mm	10 mm	72 mm	MMRM-100-25	52.45		
12 mm	12 mm	1.5 mm	25 mm	11.8 mm	12 mm	83 mm	MMRM-120-25	83.90		

*.0005" / .013 mm max TIR

HMCM

End Mills For Hardened Steels

Corner Radius – 4 Flute

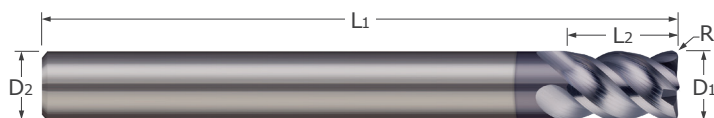

- Designed for high performance in hardened tool, die, stainless, and mold steels
- Optimized geometry for increased edge strength in hard milling applications
- Corner radius profile for added edge strength
- 45° helix ■ Center cutting
- AlTiN coating option for added lubricity and increased wear resistance in difficult-to-machine materials
- Solid carbide ■ CNC ground in the USA

Cutter Diameter*	Length of Cut	Corner Radius	Shank Diameter	Overall Length	Uncoated		AlTiN Coated	
					Tool #	Price	Tool #	Price
D1 (h8)	L2 $^{+.38 \text{ mm}}_{-.00 \text{ mm}}$	R $^{+.000 \text{ mm}}_{-.013 \text{ mm}}$	D2 (h6)	L1				
3 mm	8 mm	0.5 mm	6 mm	57 mm			HMCM-0305-4X	77.70
4 mm	11 mm	0.5 mm	6 mm	57 mm	HMCM-0405-4	72.90		
5 mm	13 mm	1.0 mm	6 mm	57 mm			HMCM-0510-4X	83.50
6 mm	13 mm	1.0 mm	6 mm	57 mm			HMCM-0610-4X	83.50
8 mm	19 mm	0.5 mm	8 mm	75 mm			HMCM-0805-4X	92.40
8 mm	19 mm	1.0 mm	8 mm	75 mm	HMCM-0810-4	84.70		
8 mm	19 mm	1.5 mm	8 mm	75 mm			HMCM-0815-4X	92.40
8 mm	19 mm	2.0 mm	8 mm	75 mm	HMCM-0820-4	84.70		
10 mm	22 mm	0.5 mm	10 mm	80 mm	HMCM-1005-4	93.35	HMCM-1005-4X	100.10
12 mm	26 mm	0.5 mm	12 mm	100 mm			HMCM-1205-4X	128.65
12 mm	26 mm	1.0 mm	12 mm	100 mm			HMCM-1210-4X	128.65
12 mm	26 mm	1.5 mm	12 mm	100 mm			HMCM-1215-4X	128.65
16 mm	32 mm	1.0 mm	16 mm	110 mm			HMCM-1610-4X	268.05
16 mm	32 mm	2.0 mm	16 mm	110 mm			HMCM-1620-4X	268.05
20 mm	38 mm	1.0 mm	20 mm	125 mm			HMCM-2010-4X	368.40
20 mm	38 mm	1.5 mm	20 mm	125 mm			HMCM-2015-4X	368.40
20 mm	38 mm	1.5 mm	20 mm	125 mm	HMCM-2015-4	345.65		
20 mm	38 mm	2.0 mm	20 mm	125 mm	HMCM-2020-4	345.65	HMCM-2020-4X	368.40
20 mm	38 mm	3.0 mm	20 mm	125 mm	HMCM-2030-4	345.65	HMCM-2030-4X	368.40

*.0005" / .013 mm max TIR

End Mills For Steels & High Temp Alloys

MEF / MEFM

Square – 2 & 3 Flute – Stub Flute

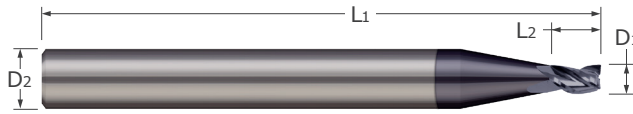

Steels & High Temp. Alloys

- Designed for high performance in titanium alloys, inconel, nickel alloys, and other high-temperature materials with outstanding performance in difficult-to-machine steels, stainless steels, and tool steels
- Stub flutes for maximum rigidity
- Square profile ■ 20° helix ■ Center cutting
- nACRo® coating option for added heat resistance in difficult-to-machine materials
- Solid carbide ■ CNC ground in the USA

Cutter Diameter*			Length of Cut	Flutes	Shank Diameter	Overall Length	Uncoated		nACRo® Coated	
D1			L2		D2 (h6)	L1	Tool #	Price	Tool #	Price
+ .0000"	+ .000 mm	decimal equiv.	+ .015"							
- .0005"	- .013 mm		- .000"							
			+ .38 mm							
			- .00 mm							
	0.1 mm	.0039	0.15 mm	2	3 mm	38 mm			MEFM-001-015K	76.10
	0.15 mm	.0059	0.25 mm	2	3 mm	38 mm			MEFM-0015-025K	62.05
	0.2 mm	.0079	0.3 mm	2	3 mm	38 mm	MEFM-002-030	48.25	MEFM-002-030K	52.45
.0100		.0100	.015	2	.1250	1.5	MEF-010-015	42.80		
	0.3 mm	.0118	0.45 mm	2	3 mm	38 mm	MEFM-003-045	42.80	MEFM-003-045K	47.05
.0150		.0150	.023	2	.1250	1.5	MEF-015-023	38.00	MEF-015-023K	42.25
.0150		.0150	.023	3	.1250	1.5	MEF-015-023-3	38.00	MEF-015-023-3K	42.25
	0.4 mm	.0157	0.6 mm	2	3 mm	38 mm	MEFM-004-060	38.00	MEFM-004-060K	42.25
.0200		.0200	.030	2	.1250	1.5			MEF-020-030K	30.90
.0200		.0200	.030	3	.1250	1.5	MEF-020-030-3	26.65		
	0.6 mm	.0236	0.9 mm	2	3 mm	38 mm	MEFM-006-090	26.65	MEFM-006-090K	30.90
.0250		.0250	.038	2	.1250	1.5	MEF-025-038	26.65	MEF-025-038K	30.90
.0250		.0250	.038	3	.1250	1.5			MEF-025-038-3K	30.90
.0300		.0300	.045	2	.1250	1.5	MEF-030-045	24.40	MEF-030-045K	28.60
.0300		.0300	.045	3	.1250	1.5	MEF-030-045-3	24.40	MEF-030-045-3K	28.60
.0313		.0313	.047	2	.1250	1.5	MEF-031-047	24.40	MEF-031-047K	28.60
.0313		.0313	.047	3	.1250	1.5			MEF-031-047-3K	28.60
	0.8 mm	.0315	1.2 mm	2	3 mm	38 mm	MEFM-008-120	24.40	MEFM-008-120K	28.60
.0350		.0350	.053	2	.1250	1.5	MEF-035-053	24.40	MEF-035-053K	28.60
.0350		.0350	.053	3	.1250	1.5			MEF-035-053-3K	28.60
	1 mm	.0394	1.5 mm	2	3 mm	38 mm	MEFM-010-150	24.40		
.0400		.0400	.060	2	.1250	1.5	MEF-040-060	24.40	MEF-040-060K	28.60
.0400		.0400	.060	3	.1250	1.5	MEF-040-060-3	24.40	MEF-040-060-3K	28.60
.0450		.0450	.068	2	.1250	1.5	MEF-045-068	24.40	MEF-045-068K	28.60
.0450		.0450	.068	3	.1250	1.5	MEF-045-068-3	24.40	MEF-045-068-3K	28.60
.0469		.0469	.071	2	.1250	1.5	MEF-047-071	24.40	MEF-047-071K	28.60
.0469		.0469	.071	3	.1250	1.5	MEF-047-071-3	24.40	MEF-047-071-3K	28.60
	1.2 mm	.0472	1.8 mm	2	3 mm	38 mm	MEFM-012-180	24.40	MEFM-012-180K	28.60
.0500		.0500	.075	2	.1250	1.5	MEF-050-075	24.40		
.0500		.0500	.075	3	.1250	1.5			MEF-050-075-3K	28.60
.0600		.0600	.090	2	.1250	1.5	MEF-060-090	24.40	MEF-060-090K	28.60

*.0005" / .013 mm max TIR

Continued on next page

MEF / MEFM

End Mills For Steels & High Temp Alloys

Square – 2 & 3 Flute – Stub Flute (cont.)

Continued from previous page

Cutter Diameter*			Length of Cut	Flutes	Shank Diameter	Overall Length	Uncoated		nACRo® Coated	
D1 +.0000" -.0005"	+.000 mm -.013 mm	decimal equiv.	L2 +.015" -.000" +.38 mm -.00 mm		D2 (h6)	L1	Tool #	Price	Tool #	Price
.0600		.0600	.090	3	.1250	1.5	MEF-060-090-3	24.40	MEF-060-090-3K	28.60
.0625		.0625	.093	2	.1250	1.5	MEF-062-093	24.40		
.0625		.0625	.093	3	.1250	1.5	MEF-062-093-3	24.40		
.0750		.0750	.113	2	.1250	1.5	MEF-075-113	24.40	MEF-075-113K	28.60
.0750		.0750	.113	3	.1250	1.5	MEF-075-113-3	24.40	MEF-075-113-3K	28.60
.0781		.0781	.117	2	.1250	1.5			MEF-078-117K	28.80
	2 mm	.0787	2.5 mm	2	3 mm	38 mm			MEFM-020-250K	28.60
.0900		.0900	.125	2	.1250	1.5	MEF-090-125	24.40		
	2.5 mm	.0984	3 mm	2	3 mm	38 mm			MEFM-025-300K	28.60
	3 mm	.1181	3 mm	2	6 mm	57 mm	MEFM-030-300	32.35		
.1250		.1250	.125	2	.1875	2.0	MEF-125-125	26.65		
	4 mm	.1575	5 mm	2	6 mm	57 mm	MEFM-040-500	32.35	MEFM-040-500K	38.45
.1875		.1875	.200	2	.2500	2.5			MEF-187-250K	40.50
D1 +.0000" -.0010"		decimal equiv.	L2 +.015" -.000"		D2 (h6)	L1	Tool #	Price	Tool #	Price
.2500		.2500	.250	2	.2500	2.5	MEF-250-250	32.35	MEF-250-250K	38.45

*.0005" / .013 mm max TIR

End Mills For Steels & High Temp Alloys

Square – 2 & 3 Flute – Long Reach, Stub Flute

MEF / MEFM

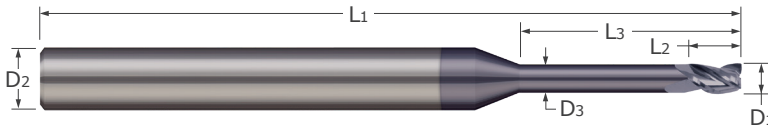

- Designed for high performance in titanium alloys, inconel, nickel alloys, and other high-temperature materials with outstanding performance in difficult-to-machine steels, stainless steels, and tool steels
- Long reach for deep pocket milling
- Stub flutes for maximum rigidity
- Reduced neck diameter to avoid heeling
- Square profile ■ 20° helix ■ Center cutting
- nACRo® coating option for added heat resistance in difficult to machine materials
- Solid carbide ■ CNC ground in the USA

Steels & High Temp. Alloys

Cutter Diameter*			Length of Cut	Overall Reach	Neck Dia.	Flutes	Shank Dia.	Overall Length	Uncoated		nACRo® Coated	
D1 +.0000" -.0005"	+.000 mm -.013 mm	decimal equiv.	L2 +.38 mm -.00 mm	L3 +.25 mm -.00 mm	D3	D2 (h6)	L1	Tool #	Price	Tool #	Price	
.0100	.0100	.0100	.015	.050	.009	2	.1250	1.5	MEF-010-050	48.50	MEF-010-050K	52.75
.0100	.0100	.0100	.015	.050	.009	3	.1250	1.5	MEF-010-050-3	48.50	MEF-010-050-3K	52.75
.0100	.0100	.0100	.015	.075	.009	2	.1250	1.5	MEF-010-075	48.50	MEF-010-075K	52.75
.0100	.0100	.0100	.015	.075	.009	3	.1250	1.5	MEF-010-075-3	48.50	MEF-010-075-3K	52.75
.0150	.0150	.0150	.023	.100	.014	2	.1250	1.5	MEF-015-100	43.65	MEF-015-100K	47.90
.0150	.0150	.0150	.023	.100	.014	3	.1250	1.5	MEF-015-100-3	43.65	MEF-015-100-3K	47.90
.0150	.0150	.0150	.023	.200	.014	2	.1250	1.5	MEF-015-200	44.80	MEF-015-200K	49.05
.0150	.0150	.0150	.023	.200	.014	3	.1250	1.5	MEF-015-200-3	44.80	MEF-015-200-3K	49.05
.0200	.0200	.0200	.030	.150	.019	2	.1250	1.5			MEF-020-150K	36.55
.0200	.0200	.0200	.030	.150	.019	3	.1250	1.5			MEF-020-150-3K	36.55
.0200	.0200	.0200	.030	.250	.019	2	.1250	1.5	MEF-020-250	33.45	MEF-020-250K	37.70
.0200	.0200	.0200	.030	.250	.019	3	.1250	1.5	MEF-020-250-3	33.45	MEF-020-250-3K	37.70
0.6 mm	.0236		0.9 mm	3 mm	0.55 mm	2	3 mm	38 mm	MEFM-006-300	32.35		
0.6 mm	.0236		0.9 mm	5 mm	0.55 mm	2	3 mm	38 mm	MEFM-006-500	33.45	MEFM-006-500K	37.70
0.6 mm	.0236		0.9 mm	6 mm	0.55 mm	2	3 mm	38 mm	MEFM-006-600	35.15	MEFM-006-600K	39.40
.0250	.0250	.0250	.038	.250	.024	3	.1250	1.5	MEF-025-250-3	33.45	MEF-025-250-3K	37.70
.0250	.0250	.0250	.038	.250	.024	2	.1250	1.5	MEF-025-250	33.45	MEF-025-250K	37.70
.0300	.0300	.0300	.045	.100	.028	2	.1250	1.5	MEF-030-100	30.05	MEF-030-100K	34.30
.0300	.0300	.0300	.045	.100	.028	3	.1250	1.5	MEF-030-100-3	30.05	MEF-030-100-3K	34.30
.0300	.0300	.0300	.045	.200	.028	2	.1250	1.5	MEF-030-200	31.20		
.0300	.0300	.0300	.045	.200	.028	3	.1250	1.5	MEF-030-200-3	31.20	MEF-030-200-3K	35.40
.0300	.0300	.0300	.045	.375	.028	2	.1250	1.5	MEF-030-375	34.60		
.0300	.0300	.0300	.045	.375	.028	3	.1250	1.5	MEF-030-375-3	34.60	MEF-030-375-3K	38.85
.0313	.0313	.0313	.047	.100	.029	2	.1250	1.5	MEF-031-100	30.05	MEF-031-100K	34.30
.0313	.0313	.0313	.047	.100	.029	3	.1250	1.5			MEF-031-100-3K	34.30
.0313	.0313	.0313	.047	.200	.029	2	.1250	1.5	MEF-031-200	31.20	MEF-031-200K	35.40
.0313	.0313	.0313	.047	.200	.029	3	.1250	1.5	MEF-031-200-3	31.20	MEF-031-200-3K	35.40
.0313	.0313	.0313	.047	.375	.029	2	.1250	1.5	MEF-031-375	34.60	MEF-031-375K	38.85
.0313	.0313	.0313	.047	.375	.029	3	.1250	1.5	MEF-031-375-3	34.60	MEF-031-375-3K	38.85

*.0005" / .013 mm max TIR

Continued on next page

MEF / MEFM

End Mills For Steels & High Temp Alloys
Square – 2 & 3 Flute – Long Reach, Stub Flute (cont.)

Continued from previous page

Cutter Diameter*			Length of Cut	Overall Reach	Neck Dia.	Flutes	Shank Dia.	Overall Length	Uncoated		nACRo® Coated	
D1 +.0000" -.0005"	+.000 mm -.013 mm	decimal equiv.	L2 +.015" -.000"	L3 +.38 mm -.00 mm	D3 +.010" -.010"	D2 (h6)	L1	Tool #	Price	Tool #	Price	
0.8 mm	.0315		1.2 mm	4 mm	0.75 mm	2	3 mm	38 mm	MEFM-008-400	32.35	MEFM-008-400K	36.55
0.8 mm	.0315		1.2 mm	7 mm	0.75 mm	2	3 mm	38 mm	MEFM-008-700	35.15	MEFM-008-700K	39.40
0.8 mm	.0315		1.2 mm	9 mm	0.75 mm	2	3 mm	38 mm			MEFM-008-900K	43.95
.0350	.0350		.053	.150	.033	2	.1250	1.5	MEF-035-150	30.05	MEF-035-150K	34.30
.0350	.0350		.053	.150	.033	3	.1250	1.5	MEF-035-150-3	30.05	MEF-035-150-3K	34.30
.0350	.0350		.053	.250	.033	2	.1250	1.5	MEF-035-250	31.20		
.0350	.0350		.053	.250	.033	3	.1250	1.5	MEF-035-250-3	31.20	MEF-035-250-3K	35.40
.0350	.0350		.053	.400	.033	3	.1250	1.5	MEF-035-400-3	34.60	MEF-035-400-3K	38.85
1 mm	.0394		1.5 mm	4 mm	0.95 mm	2	3 mm	38 mm			MEFM-010-400K	36.55
1 mm	.0394		1.5 mm	7 mm	0.95 mm	2	3 mm	38 mm	MEFM-010-700	35.15	MEFM-010-700K	39.40
.0400	.0400		.060	.250	.038	2	.1250	1.5			MEF-040-250K	35.40
.0400	.0400		.060	.250	.038	3	.1250	1.5	MEF-040-250-3	31.20		
.0400	.0400		.060	.500	.038	2	.1250	1.5	MEF-040-500	36.85	MEF-040-500K	41.10
.0400	.0400		.060	.500	.038	3	.1250	1.5	MEF-040-500-3	36.85	MEF-040-500-3K	41.10
.0450	.0450		.068	.150	.043	2	.1250	1.5	MEF-045-150	30.05	MEF-045-150K	34.30
.0450	.0450		.068	.150	.043	3	.1250	1.5	MEF-045-150-3	30.05	MEF-045-150-3K	34.30
.0450	.0450		.068	.250	.043	2	.1250	1.5	MEF-045-250	31.20	MEF-045-250K	35.40
.0450	.0450		.068	.250	.043	3	.1250	1.5	MEF-045-250-3	31.20	MEF-045-250-3K	35.40
.0450	.0450		.068	.500	.043	2	.1250	1.5	MEF-045-500	36.85	MEF-045-500K	41.10
.0450	.0450		.068	.500	.043	3	.1250	1.5	MEF-045-500-3	36.85	MEF-045-500-3K	41.10
.0469	.0469		.071	.150	.045	2	.1250	1.5	MEF-047-150	30.05	MEF-047-150K	34.30
.0469	.0469		.071	.150	.045	3	.1250	1.5	MEF-047-150-3	30.05	MEF-047-150-3K	34.30
.0469	.0469		.071	.250	.045	2	.1250	1.5	MEF-047-250	31.20	MEF-047-250K	35.40
.0469	.0469		.071	.250	.045	3	.1250	1.5	MEF-047-250-3	31.20	MEF-047-250-3K	35.40
.0469	.0469		.071	.500	.045	2	.1250	1.5	MEF-047-500	36.85	MEF-047-500K	41.10
.0469	.0469		.071	.500	.045	3	.1250	1.5	MEF-047-500-3	36.85	MEF-047-500-3K	41.10
1.2 mm	.0472		1.8 mm	6 mm	1.1 mm	2	3 mm	38 mm	MEFM-012-600	35.15	MEFM-012-600K	39.40
1.2 mm	.0472		1.8 mm	10 mm	1.1 mm	2	3 mm	38 mm	MEFM-012-1000	39.70	MEFM-012-1000K	43.95
1.2 mm	.0472		1.8 mm	12 mm	1.1 mm	2	3 mm	38 mm	MEFM-012-1200	42.80	MEFM-012-1200K	47.05
.0500	.0500		.075	.200	.048	2	.1250	1.5			MEF-050-200K	34.30
.0500	.0500		.075	.200	.048	3	.1250	1.5	MEF-050-200-3	30.05	MEF-050-200-3K	34.30
.0500	.0500		.075	.300	.048	2	.1250	1.5	MEF-050-300	32.35	MEF-050-300K	36.55
.0500	.0500		.075	.300	.048	3	.1250	1.5	MEF-050-300-3	32.35		
.0500	.0500		.075	.550	.048	2	.1250	1.5			MEF-050-550K	41.10
.0500	.0500		.075	.550	.048	3	.1250	1.5			MEF-050-550-3K	41.10
1.5 mm	.0591		2.2 mm	6 mm	1.4 mm	2	3 mm	38 mm	MEFM-015-600	35.15		
1.5 mm	.0591		2.2 mm	10 mm	1.4 mm	2	3 mm	38 mm	MEFM-015-1000	39.70	MEFM-015-1000K	43.95
1.5 mm	.0591		2.2 mm	12 mm	1.4 mm	2	3 mm	38 mm	MEFM-015-1200	42.80	MEFM-015-1200K	47.05
.0600	.0600		.090	.200	.056	2	.1250	1.5	MEF-060-200	30.05		
.0600	.0600		.090	.200	.056	3	.1250	1.5	MEF-060-200-3	30.05	MEF-060-200-3K	34.30
.0600	.0600		.090	.350	.056	2	.1250	1.5	MEF-060-350	32.35	MEF-060-350K	36.55
.0600	.0600		.090	.350	.056	3	.1250	1.5	MEF-060-350-3	32.35		

*.0005" / .013 mm max TIR

Continued on next page

Steels & High Temp. Alloys

End Mills For Steels & High Temp Alloys

Square – 2 & 3 Flute – Long Reach, Stub Flute (cont.)

MEF / MEFM

Continued from previous page

Steels & High Temp. Alloys

Cutter Diameter*			Length of Cut	Overall Reach	Neck Dia.	Flutes	Shank Dia.	Overall Length	Uncoated		nACRo® Coated	
D1			L2	L3	D3		D2 (h6)	L1	Tool #	Price	Tool #	Price
+ .0000"	+ .000 mm	decimal equiv.	+ .015"	+ .010"								
- .0005"	- .013 mm		+ .38 mm	+ .25 mm								
			- .00 mm	- .00 mm								
.0600	.0600	.0600	.090	.500	.056	2	.1250	1.5	MEF-060-500	36.85	MEF-060-500K	41.10
.0600	.0600	.0600	.090	.500	.056	3	.1250	1.5	MEF-060-500-3	36.85	MEF-060-500-3K	41.10
.0600	.0600	.0600	.090	.750	.056	2	.1250	2.0	MEF-060-750	42.55	MEF-060-750K	46.80
.0600	.0600	.0600	.090	.750	.056	3	.1250	2.0	MEF-060-750-3	42.55	MEF-060-750-3K	46.80
.0625	.0625	.0625	.093	.200	.058	2	.1250	1.5	MEF-062-200	30.05	MEF-062-200K	34.30
.0625	.0625	.0625	.093	.200	.058	3	.1250	1.5	MEF-062-200-3	30.05	MEF-062-200-3K	34.30
.0625	.0625	.0625	.093	.350	.058	2	.1250	1.5	MEF-062-350	32.35	MEF-062-350K	36.55
.0625	.0625	.0625	.093	.350	.058	3	.1250	1.5			MEF-062-350-3K	36.55
.0625	.0625	.0625	.093	.550	.058	2	.1250	1.5	MEF-062-550	36.85	MEF-062-550K	41.10
.0625	.0625	.0625	.093	.750	.058	2	.1250	2.0	MEF-062-750	42.55		
.0625	.0625	.0625	.093	.750	.058	3	.1250	2.0	MEF-062-750-3	42.55	MEF-062-750-3K	46.80
.0750	.0750	.0750	.113	.250	.071	2	.1250	1.5	MEF-075-250	30.05	MEF-075-250K	34.30
.0750	.0750	.0750	.113	.250	.071	3	.1250	1.5	MEF-075-250-3	30.05	MEF-075-250-3K	34.30
.0750	.0750	.0750	.113	.400	.071	2	.1250	1.5			MEF-075-400K	36.55
.0750	.0750	.0750	.113	.400	.071	3	.1250	1.5	MEF-075-400-3	32.35	MEF-075-400-3K	36.55
.0750	.0750	.0750	.113	.600	.071	2	.1250	2.0	MEF-075-600	36.85		
.0750	.0750	.0750	.113	.600	.071	3	.1250	2.0	MEF-075-600-3	36.85		
.0750	.0750	.0750	.113	.900	.071	2	.1250	2.0	MEF-075-900	44.25	MEF-075-900K	48.50
.0750	.0750	.0750	.113	.900	.071	3	.1250	2.0	MEF-075-900-3	44.25	MEF-075-900-3K	48.50
.0781	.0781	.0781	.117	.250	.074	2	.1250	1.5	MEF-078-250	30.05	MEF-078-250K	34.30
.0781	.0781	.0781	.117	.250	.074	3	.1250	1.5	MEF-078-250-3	30.05		
.0781	.0781	.0781	.117	.400	.074	2	.1250	1.5	MEF-078-400	32.35	MEF-078-400K	36.55
.0781	.0781	.0781	.117	.400	.074	3	.1250	1.5	MEF-078-400-3	32.35		
.0781	.0781	.0781	.117	.650	.074	2	.1250	2.0	MEF-078-650	36.85	MEF-078-650K	41.10
.0781	.0781	.0781	.117	.650	.074	3	.1250	2.0			MEF-078-650-3K	41.10
.0781	.0781	.0781	.117	.900	.074	2	.1250	2.0	MEF-078-900	44.25	MEF-078-900K	48.50
.0781	.0781	.0781	.117	.900	.074	3	.1250	2.0	MEF-078-900-3	44.25	MEF-078-900-3K	48.50
2 mm	.0787	2.5 mm	7 mm	19 mm	1.9 mm	2	3 mm	38 mm	MEFM-020-700	35.15	MEFM-020-700K	39.40
2 mm	.0787	2.5 mm	12 mm	19 mm	1.9 mm	2	3 mm	38 mm			MEFM-020-1200K	47.05
2 mm	.0787	2.5 mm	16 mm	19 mm	1.9 mm	2	3 mm	38 mm			MEFM-020-1600K	49.60
2 mm	.0787	2.5 mm	20 mm	19 mm	1.9 mm	2	3 mm	50 mm	MEFM-020-2000	56.70	MEFM-020-2000K	60.95
2 mm	.0787	2.5 mm	25 mm	19 mm	1.9 mm	2	3 mm	50 mm	MEFM-020-2500	64.65	MEFM-020-2500K	68.90
.0900	.0900	.0900	.125	.250	.086	2	.1250	1.5	MEF-090-250	30.05	MEF-090-250K	34.30
.0900	.0900	.0900	.125	.400	.086	2	.1250	1.5	MEF-090-400	32.35	MEF-090-400K	36.55
.0900	.0900	.0900	.125	.900	.086	2	.1250	2.0	MEF-090-900	40.30	MEF-090-900K	44.50
.0938	.0938	.0938	.125	.250	.089	2	.1250	1.5	MEF-093-250	30.05		
.0938	.0938	.0938	.125	.500	.089	2	.1250	1.5			MEF-093-500K	36.55
.0938	.0938	.0938	.125	.750	.089	2	.1250	2.0	MEF-093-750	36.85	MEF-093-750K	41.10
.0938	.0938	.0938	.125	1.000	.089	2	.1250	2.0	MEF-093-1000	42.55	MEF-093-1000K	46.80
2.5 mm	.0984	3 mm	10 mm	24 mm	2.4 mm	2	3 mm	38 mm	MEFM-025-1000	39.10	MEFM-025-1000K	43.35
2.5 mm	.0984	3 mm	20 mm	24 mm	2.4 mm	2	3 mm	50 mm	MEFM-025-2000	56.70	MEFM-025-2000K	60.95
2.5 mm	.0984	3 mm	25 mm	24 mm	2.4 mm	2	3 mm	50 mm	MEFM-025-2500	64.65	MEFM-025-2500K	68.90
3 mm	.1181	3 mm	15 mm	29 mm	2.9 mm	2	6 mm	57 mm	MEFM-030-1500	46.45	MEFM-030-1500K	52.50
3 mm	.1181	3 mm	30 mm	29 mm	2.9 mm	2	6 mm	57 mm			MEFM-030-3000K	69.85

*.0005" / .013 mm max TIR

Continued on next page

MEF / MEFM

End Mills For Steels & High Temp Alloys
Square – 2 & 3 Flute – Long Reach, Stub Flute (cont.)

Continued from previous page

Cutter Diameter*			Length of Cut	Overall Reach	Neck Dia.	Flutes	Shank Dia.	Overall Length	Uncoated		nACRo® Coated	
D1 +.0000" -.0005"	+ .000 mm -.013 mm	decimal equiv.	L2 +.015" -.000" +.38 mm -.00 mm	L3 +.010" -.010" +.25 mm -.00 mm	D3	D2 (h6)	L1	Tool #	Price	Tool #	Price	
.1250	.1250	.1250	.125	1.000	.121	2	.1875	2.0	MEF-125-1000	42.55	MEF-125-1000K	47.35
.1250	.1250	.1250	.125	1.500	.121	2	.1875	3.0	MEF-125-1500	48.70		
4 mm	.1575	5 mm	30 mm	3.9 mm	2	6 mm	57 mm	MEFM-040-3000	62.35	MEFM-040-3000K	68.40	
.1875	.1875	.200	1.000	.183	2	.2500	2.5			MEF-187-1000K	60.45	
.1875	.1875	.200	1.500	.183	2	.2500	3	MEF-187-1500	62.35	MEF-187-1500K	68.40	
.1875	.1875	.200	.500	.183	2	.2500	2.5	MEF-187-500	39.45			
.1875	.1875	.200	.750	.183	2	.2500	2.5	MEF-187-750	46.45	MEF-187-750K	52.50	
5 mm	.1969	6 mm	25 mm	4.9 mm	2	6 mm	57 mm	MEFM-050-2500	54.40	MEFM-050-2500K	60.45	
5 mm	.1969	6 mm	30 mm	4.9 mm	2	6 mm	57 mm	MEFM-050-3000	62.35	MEFM-050-3000K	68.40	
D1 +.0000" -.0010"	decimal equiv.	L2 +.015" -.000"	L3 +.010" -.010"	D3	D2 (h6)	L1	Tool #	Price	Tool #	Price		
.2500	.2500	.250	1.000	.246	2	.2500	2.5	MEF-250-1000	54.40	MEF-250-1000K	60.45	
.2500	.2500	.250	1.500	.246	2	.2500	3.0	MEF-250-1500	62.35			
.2500	.2500	.250	.750	.246	2	.2500	2.5	MEF-250-750	46.45	MEF-250-750K	52.50	

*.0005" / .013 mm max TIR

Steels & High Temp. Alloys

End Mills For Steels & High Temp Alloys

SDH / SDHM

Square – 3 & 4 Flute

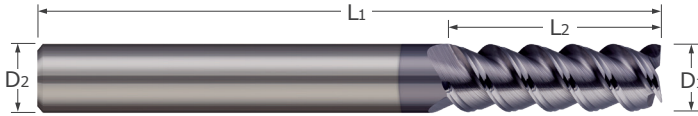

Steels & High Temp. Alloys

- Designed for high performance in titanium alloys, inconel, nickel alloys, and other high-temperature materials with outstanding performance in difficult-to-machine steels, stainless steels, and tool steels
- 60° high helix for reduced cutting forces and increased material removal rates
- Square profile ■ Center cutting
- AlTiN coating option for added lubricity and increased wear resistance in difficult-to-machine materials
- Solid carbide ■ CNC ground in the USA

Cutter Diameter*			Length of Cut	Flutes	Shank Diameter	Overall Length	Uncoated		AlTiN Coated	
D1 +.0000" -.0030"	(h9)	decimal equiv.					L2 +.78 mm -.00 mm	D2 (h6)	L1	Tool #
6 mm		.2362	18 mm	3	6 mm	57 mm	SDHM-060-3	24.65		
.2500		.2500	.750	3	.2500	2.5	SDH-250-03	30.00	SDH-250-03X	35.25
.2813		.2813	.750	3	.3125	2.5	SDH-281-03	34.80		
12 mm		.4724	30 mm	4	12 mm	83 mm	SDHM-120-4	57.30		
.5000		.5000	1.000	3	.5000	3.0	SDH-500-03	68.80		
.5000		.5000	1.000	4	.5000	3.0	SDH-500-04	68.80	SDH-500-04X	77.40
14 mm		.5512	35 mm	3	14 mm	83 mm	SDHM-140-3	69.85		
16 mm		.6299	35 mm	3	16 mm	92 mm			SDHM-160-3X	124.35
18 mm		.7087	45 mm	3	18 mm	92 mm	SDHM-180-3	149.80	SDHM-180-3X	164.45
18 mm		.7087	45 mm	4	18 mm	92 mm	SDHM-180-4	149.80		
20 mm		.7874	45 mm	3	20 mm	104 mm			SDHM-200-3X	211.70
20 mm		.7874	45 mm	4	20 mm	104 mm	SDHM-200-4	191.00		

*.0005" / .013 mm max TIR

**SHR / SHRM
SHL / SHLM**

End Mills For Steels & High Temp Alloys

Square – 4 Flute – Chipbreaker Rougher

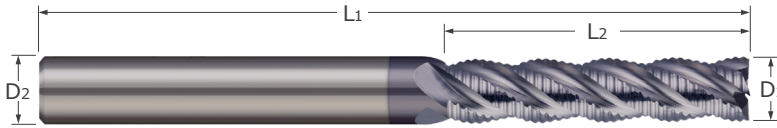

- Designed for roughing in titanium alloys, inconel, nickel alloys, and other high-temperature materials with outstanding performance in difficult-to-machine steels, stainless steels, and tool steels
- Integrated chipbreaker geometry generates increased material removal rates
- Available in standard and long length of cut options
- Weldon flat featured on sizes 3/8" and larger
- Square profile ■ 38° helix ■ Center cutting
- AlTiN coating option for added lubricity and increased wear resistance in difficult-to-machine materials
- Solid carbide ■ CNC ground in the USA

Cutter Diameter*		Length of Cut L2	Flutes	Shank Dia. D2 (h6)	Overall Length L1	Uncoated		AlTiN Coated	
D1 +.0000" -.0030" (h9)	decimal equiv.					Tool #	Price	Tool #	Price
6 mm	.2362	16 mm	4	6 mm	57 mm	SHRM-060-4	40.95	SHRM-060-4X	46.05
6 mm	.2362	25 mm	4	6 mm	75 mm	SHLM-060-4	52.30	SHLM-060-4X	57.30
.2500	.2500	.750	4	.2500	2.5			SHR-250-4X	46.70
.2500	.2500	1.125	4	.2500	3.0			SHL-250-4X	58.20
.3125	.3125	.813	4	.3125	2.5			SHR-312-4X	53.60
.3125	.3125	1.125	4	.3125	3.0			SHL-312-4X	66.85
8 mm	.3150	22 mm	4	8 mm	63 mm			SHRM-080-4X	54.75
8 mm	.3150	30 mm	4	8 mm	75 mm	SHLM-080-4	60.00		
.3750	.3750	.875	4	.3750	2.5	SHR-375-4	58.40	SHR-375-4X	65.50
.3750	.3750	1.250	4	.3750	3.0			SHL-375-4X	82.65
10 mm	.3937	25 mm	4	10 mm	72 mm			SHRM-100-4X	71.15
10 mm	.3937	38 mm	4	10 mm	100 mm	SHLM-100-4	78.65	SHLM-100-4X	87.35
12 mm	.4724	30 mm	4	12 mm	83 mm			SHRM-120-4X	92.75
12 mm	.4724	50 mm	4	12 mm	100 mm	SHLM-120-4	105.70	SHLM-120-4X	118.35
.5000	.5000	1.000	4	.5000	3.0	SHR-500-4	85.40	SHR-500-4X	93.80
.5000	.5000	2.000	4	.5000	4.5			SHL-500-4X	120.40
14 mm	.5512	35 mm	4	14 mm	83 mm	SHRM-140-4	136.80	SHRM-140-4X	148.30
.6250	.6250	1.250	4	.6250	3.5	SHR-625-4	151.65	SHR-625-4X	164.15
.6250	.6250	2.500	4	.6250	5.0			SHL-625-4X	207.80
16 mm	.6299	35 mm	4	16 mm	92 mm			SHRM-160-4X	165.10
16 mm	.6299	75 mm	4	16 mm	150 mm			SHLM-160-4X	211.65
18 mm	.7087	75 mm	4	18 mm	150 mm			SHLM-180-4X	295.90
.7500	.7500	1.500	4	.7500	4.0			SHR-750-4X	227.55
.7500	.7500	2.500	4	.7500	5.0	SHL-750-4	270.25	SHL-750-4X	289.05
20 mm	.7874	45 mm	4	20 mm	104 mm			SHRM-200-4X	273.05

*.0005" / .013 mm max TIR

End Mills For Steels & High Temp Alloys

Square – 5 Flute – Stub & Standard

ASM / ASMM
ARM / ARMM

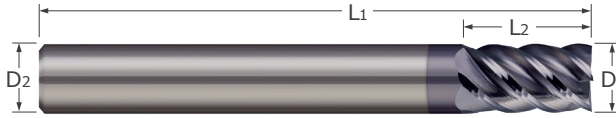

Steels & High Temp. Alloys

- Designed for applications in titanium alloys, inconel, nickel alloys, and other high-temperature materials with outstanding performance in difficult-to-machine steels, stainless steels, and tool steels
- 45° high helix for reduced cutting forces and increased material removal rates
- Stub flutes for maximum rigidity
- Square profile ■ Center cutting
- AlTiN coating option for added lubricity and increased wear resistance in difficult-to-machine materials
- Solid carbide ■ CNC ground in the USA

Cutter Diameter*			Length of Cut	Flutes	Shank Dia.	Overall Length	Uncoated		AlTiN Coated	
D1 +.0000" -.0020" (h9) decimal equiv.			L2 +.031" -.000" +.79 mm -.00 mm		D2 (h6)	L1	Tool #	Price	Tool #	Price
3 mm	.1181	.1181	6 mm	5	6 mm	57 mm	ASMM-030-5	29.30	ASMM-030-5X	34.55
3 mm	.1181	.1181	10 mm	5	6 mm	57 mm	ARMM-030-5	30.85		
4 mm	.1575	.1575	15 mm	5	6 mm	57 mm	ARMM-040-5	30.85		
.1875	.1875	.1875	.625	5	.1875	2.0	ARM-187-5	26.15		
5 mm	.1969	.1969	10 mm	5	6 mm	57 mm	ASMM-050-5	29.30	ASMM-050-5X	34.55
.2500	.2500	.2500	.750	5	.2500	2.5	ARM-250-5	32.75	ARM-250-5X	38.00

D1 +.0000" -.0030" (h9) decimal equiv.			L2 +.031" -.000" +.79 mm -.00 mm		D2 (h6)	L1	Tool #	Price	Tool #	Price
.3125	.3125	.3125	.500	5	.3125	2.0	ASM-312-5	32.60		
8 mm	.3150	.3150	16 mm	5	8 mm	63 mm	ASMM-080-5	34.70		
.3750	.3750	.3750	.625	5	.3750	2.0	ASM-375-5	40.55		
10 mm	.3937	.3937	19 mm	5	10 mm	72 mm	ASMM-100-5	41.10		
10 mm	.3937	.3937	25 mm	5	10 mm	72 mm	ARMM-100-5	43.10	ARMM-100-5X	50.35
12 mm	.4724	.4724	22 mm	5	12 mm	83 mm	ASMM-120-5	65.95		
.5000	.5000	.5000	.625	5	.5000	2.0	ASM-500-5	63.75	ASM-500-5X	72.25
.5000	.5000	.5000	1.000	5	.5000	3.0	ARM-500-5	71.95	ARM-500-5X	80.50
14 mm	.5512	.5512	30 mm	5	14 mm	83 mm			ARMM-140-5X	111.65
16 mm	.6299	.6299	35 mm	5	16 mm	92 mm			ARMM-160-5X	140.15
18 mm	.7087	.7087	45 mm	5	18 mm	92 mm			ARMM-180-5X	185.50

*.0005" / .013 mm max TIR

VHS / VHM

End Mills For Steels & High Temp Alloys

Square – 5 Flute – Variable Helix

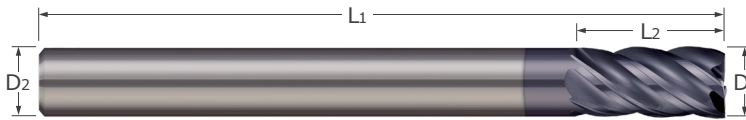

- Designed for high performance in titanium alloys, inconel, nickel alloys, and other high-temperature materials with outstanding performance in difficult-to-machine steels, stainless steels, and tool steels
- Variable helix design reduces chatter and harmonics and increases material removal rates
- Square profile ■ Center cutting
- nACRo® coating option for added heat resistance in difficult to machine materials
- Solid carbide ■ CNC ground in the USA

Cutter Diameter	Length of Cut	Flutes	Shank Diameter	Overall Length	Uncoated		nACRo® Coated	
					Tool #	Price	Tool #	Price
D1 $\begin{matrix} +.0000'' \\ -.0020'' \end{matrix}$	L2 $\begin{matrix} +.015'' \\ -.000'' \end{matrix}$		D2 (h6)	L1				
.2500	.750	5	.2500	2.5	VHM-250-5	33.45		
D1 $\begin{matrix} +.0000'' \\ -.0030'' \end{matrix}$	L2 $\begin{matrix} +.015'' \\ -.000'' \end{matrix}$		D2 (h6)	L1				
.5000	.625	5	.5000	3.0			VHS-500-5K	79.30
.5000	1.000	5	.5000	3.0			VHM-500-5K	86.65
.5000	1.250	5	.5000	3.5	VHM-5125-5	78.60	VHM-5125-5K	91.25
.7500	1.500	5	.7500	4.0	VHM-750-5	207.55		

Steels & High Temp. Alloys

End Mills For Steels & High Temp Alloys

EMH / EMHM

Square – 4 & 6 Flute

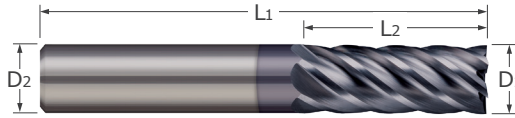

Steels & High Temp. Alloys

- Designed for finishing in titanium alloys, inconel, nickel alloys, and other high-temperature materials with outstanding performance in difficult-to-machine steels, stainless steels, and tool steels
- 38° helix for superior surface finish
- Square profile
- Weldon flat featured on sizes 3/8" and larger on ANSI shanks only
- Center cutting
- AlTiN coating option for added lubricity and increased wear resistance in difficult-to-machine materials
- Solid carbide ■ CNC ground in the USA

Cutter Diameter*			Length of Cut	Flutes	Shank Dia.	Overall Length	Uncoated		AlTiN Coated	
D1 +.0000" -.0002" (h9)	decimal equiv.	L2 +.030" -.000" +.78 mm -.00 mm			D2 (h6)	L1	Tool #	Price	Tool #	Price
3 mm	.1181	8 mm	4	4 mm	50 mm	EMHM-030-4	19.65			
4 mm	.1574	12 mm	4	4 mm	50 mm	EMHM-040-4	19.65			
6 mm	.2362	18 mm	4	6 mm	57 mm			EMHM-060-4X	29.95	
6 mm	.2362	18 mm	6	6 mm	57 mm	EMHM-060-6	24.65	EMHM-060-6X	29.95	
D1 +.0000" -.0003" (h9)	decimal equiv.	L2 +.030" -.000" +.78 mm -.00 mm			D2 (h6)	L1	Tool #	Price	Tool #	Price
.2813	.2813	.750	6	.3125	2.5	EMH-281-06	38.10	EMH-281-06X	45.40	
8 mm	.3150	20 mm	4	8 mm	63 mm	EMHM-080-4	30.55	EMHM-080-4X	37.85	
10 mm	.3937	22 mm	6	10 mm	72 mm			EMHM-100-6X	43.00	
12 mm	.4724	25 mm	6	12 mm	83 mm	EMHM-120-6	57.30			
14 mm	.5512	30 mm	6	14 mm	83 mm	EMHM-140-6	69.85			
.6250	.6250	1.250	6	.6250	3.5	EMH-625-06	132.40			
16 mm	.6299	35 mm	6	16 mm	92 mm			EMHM-160-6X	124.30	
20 mm	.7874	45 mm	6	20 mm	104 mm			EMHM-200-6X	211.70	

*.0005" / .013 mm max TIR

BEF / BEFM

End Mills For Steels & High Temp Alloys

Ball – 2 & 3 Flute – Stub Flute

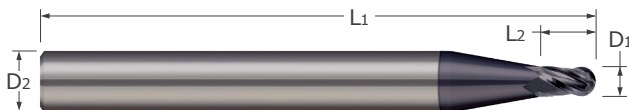

- Designed for high performance in titanium alloys, inconel, nickel alloys, and other high-temperature materials with outstanding performance in difficult-to-machine steels, stainless steels, and tool steels
- Stub flutes for maximum rigidity
- Ball profile
- 20° helix
- Center cutting
- nACRo® coating option for added heat resistance in difficult to machine materials
- Solid carbide ■ CNC ground in the USA

Cutter Diameter*			Length of Cut L2	Flutes	Shank Diameter D2 (h6)	Overall Length L1	Uncoated		nACRo® Coated	
D1 +.0000" -.0005"	+ .000 mm -.013 mm	decimal equiv.					Tool #	Price	Tool #	Price
0.2 mm		.0079	0.3 mm	2	3 mm	38 mm	BEFM-002-030	56.35	BEFM-002-030K	60.60
0.3 mm		.0118	0.45 mm	2	3 mm	38 mm	BEFM-003-045	50.20		
.0150		.0150	.023	2	.1250	1.5			BEF-015-023K	49.20
.0200		.0200	.030	2	.1250	1.5			BEF-020-030K	35.70
.0200		.0200	.030	3	.1250	1.5	BEF-020-030-3	31.50	BEF-020-030-3K	35.70
0.6 mm		.0236	0.9 mm	2	3 mm	38 mm			BEFM-006-090K	35.70
.0313		.0313	.047	3	.1250	1.5	BEF-031-047-3	28.95		
0.8 mm		.0315	1.2 mm	2	3 mm	38 mm			BEFM-008-120K	33.30
.0350		.0350	.053	3	.1250	1.5	BEF-035-053-3	28.95	BEF-035-053-3K	33.20
1 mm		.0394	1.5 mm	2	3 mm	38 mm	BEFM-010-150	28.95		
.0400		.0400	.060	2	.1250	1.5	BEF-040-060	28.95	BEF-040-060K	33.20
.0400		.0400	.060	3	.1250	1.5	BEF-040-060-3	28.95	BEF-040-060-3K	33.20
.0450		.0450	.068	2	.1250	1.5	BEF-045-068	28.95	BEF-045-068K	33.20
.0450		.0450	.068	3	.1250	1.5	BEF-045-068-3	28.95	BEF-045-068-3K	33.20
.0469		.0469	.071	3	.1250	1.5			BEF-047-071-3K	33.20
1.2 mm		.0472	1.8 mm	2	3 mm	38 mm			BEFM-012-180K	33.30
.0500		.0500	.075	2	.1250	1.5	BEF-050-075	28.95		
.0500		.0500	.075	3	.1250	1.5	BEF-050-075-3	28.95	BEF-050-075-3K	33.20
1.5 mm		.0591	2.2 mm	2	3 mm	38 mm			BEFM-015-220K	33.30
.0600		.0600	.090	2	.1250	1.5	BEF-060-090	28.95	BEF-060-090K	33.20
.0600		.0600	.090	3	.1250	1.5	BEF-060-090-3	28.95	BEF-060-090-3K	33.20
.0625		.0625	.093	2	.1250	1.5	BEF-062-093	28.95		
.0625		.0625	.093	3	.1250	1.5	BEF-062-093-3	28.95		
.0750		.0750	.113	2	.1250	1.5			BEF-075-113K	33.20
.0750		.0750	.113	3	.1250	1.5	BEF-075-113-3	28.95	BEF-075-113-3K	33.20
.0781		.0781	.117	2	.1250	1.5			BEF-078-117K	33.20
.0781		.0781	.117	3	.1250	1.5	BEF-078-117-3	28.95	BEF-078-117-3K	33.20
.0900		.0900	.125	2	.1250	1.5	BEF-090-125	28.95	BEF-090-125K	33.20

*.0005" / .013 mm max TIR

Continued on next page

End Mills For Steels & High Temp Alloys

Ball – 2 & 3 Flute – Stub Flute (cont.)

Continued from previous page

Cutter Diameter*			Length of Cut	Flutes	Shank Diameter	Overall Length	Uncoated		nACRo® Coated	
D1			L2		D2 (h6)	L1	Tool #	Price	Tool #	Price
+.0000" -.0005"	+.000 mm -.013 mm	decimal equiv.	+.015" -.000" +.38 mm -.00 mm							
.0938		.0938	.125	2	.1250	1.5	BEF-093-125	28.95		
	2.5 mm	.0984	3 mm	2	3 mm	38 mm	BEFM-025-300	28.95		
	3 mm	.1181	3 mm	2	6 mm	57 mm	BEFM-030-300	41.85		
.1250		.1250	.125	2	.1875	2.0	BEF-125-125	31.20		
	4 mm	.1575	5 mm	2	6 mm	57 mm			BEFM-040-500K	47.10
.1875		.1875	.200	2	.2500	2.5	BEF-187-250	41.85	BEF-187-250K	47.95
	5 mm	.1969	6 mm	2	6 mm	57 mm	BEFM-050-600	41.85	BEFM-050-600K	47.10
D1	+.0000" -.0010"	decimal equiv.	L2	+.015" -.000"	D2 (h6)	L1	Tool #	Price	Tool #	Price
.2500		.2500	.250	2	.2500	2.5	BEF-250-250	41.85		

*.0005" / .013 mm max TIR

Steels & High Temp. Alloys

BEF / BEFM

End Mills For Steels & High Temp Alloys

Ball – 2 & 3 Flute – Long Reach, Stub Flute

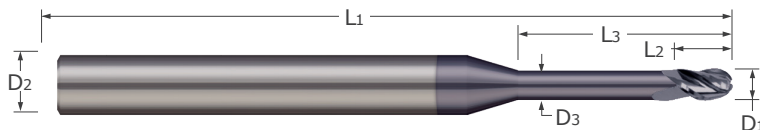

- Designed for high performance in titanium alloys, inconel, nickel alloys, and other high-temperature materials with outstanding performance in difficult-to-machine steels, stainless steels, and tool steels
- Long reach for deep pocket milling
- Stub flutes for maximum rigidity
- Reduced neck diameter to avoid heeling
- Ball profile ■ 20° helix ■ Center cutting
- nACRo® coating option for added heat resistance in difficult to machine materials
- Solid carbide ■ CNC ground in the USA

Cutter Diameter*	Length of Cut	Overall Reach	Neck Dia.	Flutes	Shank Dia.	Overall Length	Uncoated		nACRo® Coated	
							Tool #	Price	Tool #	Price
D1 +.0000" +.000 mm -.0005" -.013 mm decimal equiv.	L2 +.015" -.000"	L3 +.010" -.000"	D3		D2 (h6)	L1				
.0150	.023	.100	.014	2	.1250	1.5	BEF-015-100	50.20	BEF-015-100K	54.45
.0150	.023	.200	.014	2	.1250	1.5	BEF-015-200	51.30	BEF-015-200K	55.55
.0150	.023	.200	.014	3	.1250	1.5	BEF-015-200-3	51.30		
.0150	.023	.200	.014	3	.1250	1.5			BEF-015-200-3K	55.55
0.5 mm	.0197	0.7 mm	3 mm	0.45 mm	2	3 mm	38 mm	BEFM-005-300	37.15	
0.5 mm	.0197	0.7 mm	6 mm	0.45 mm	2	3 mm	38 mm			BEFM-005-600K 43.95
.0200	.030	.150	.019	2	.1250	1.5	BEF-020-150	37.15		
.0200	.030	.150	.019	3	.1250	1.5	BEF-020-150-3	37.15		
.0200	.030	.250	.019	3	.1250	1.5	BEF-020-250-3	38.25		
0.6 mm	.0236	0.9 mm	3 mm	0.55 mm	2	3 mm	38 mm	BEFM-006-300	37.15	
0.6 mm	.0236	0.9 mm	5 mm	0.55 mm	2	3 mm	38 mm	BEFM-006-500	38.25	BEFM-006-500K 42.50
0.6 mm	.0236	0.9 mm	6 mm	0.55 mm	2	3 mm	38 mm	BEFM-006-600	39.70	BEFM-006-600K 43.95
.0250	.038	.150	.024	2	.1250	1.5	BEF-025-150	37.15	BEF-025-150K	41.40
.0250	.038	.150	.024	3	.1250	1.5	BEF-025-150-3	37.15	BEF-025-150-3K	41.40
.0250	.038	.250	.024	2	.1250	1.5	BEF-025-250	38.25	BEF-025-250K	42.50
.0250	.038	.250	.024	3	.1250	1.5	BEF-025-250-3	38.25	BEF-025-250-3K	42.50
.0300	.045	.125	.028	2	.1250	1.5	BEF-030-100	34.60	BEF-030-100K	38.85
.0300	.045	.125	.028	3	.1250	1.5	BEF-030-100-3	34.60	BEF-030-100-3K	38.85
.0300	.045	.200	.028	2	.1250	1.5	BEF-030-200	35.70		
.0300	.045	.200	.028	3	.1250	1.5	BEF-030-200-3	35.70	BEF-030-200-3K	39.95
.0300	.045	.375	.028	2	.1250	1.5			BEF-030-375K	39.95
.0300	.045	.375	.028	3	.1250	1.5	BEF-030-375-3	35.70	BEF-030-375-3K	39.95
.0313	.047	.125	.029	2	.1250	1.5	BEF-031-100	34.60	BEF-031-100K	38.85
.0313	.047	.125	.029	3	.1250	1.5	BEF-031-100-3	34.60	BEF-031-100-3K	38.85
.0313	.047	.200	.029	2	.1250	1.5	BEF-031-200	35.70	BEF-031-200K	39.95
.0313	.047	.200	.029	3	.1250	1.5	BEF-031-200-3	35.70		
.0313	.047	.375	.029	2	.1250	1.5	BEF-031-375	39.10	BEF-031-375K	43.35
.0313	.047	.375	.029	3	.1250	1.5	BEF-031-375-3	39.10	BEF-031-375-3K	43.35

*.0005" / .013 mm max TIR

Continued on next page

End Mills For Steels & High Temp Alloys

Ball – 2 & 3 Flute – Long Reach, Stub Flute (cont.)

BEF / BEFM

Continued from previous page

Steels & High Temp. Alloys

Cutter Diameter*			Length of Cut	Overall Reach	Neck Dia.	Flutes	Shank Dia.	Overall Length	Uncoated		nACRo® Coated	
D1 +.0000" -.0005"	+.000 mm -.013 mm	decimal equiv.	L2 +.015" -.000"	L3 +.010" -.000"	D3 +.25 mm -.00 mm	D2 (h6)	L1	Tool #	Price	Tool #	Price	
			+.38 mm -.00 mm	+.25 mm -.00 mm								
0.8 mm	.0315		1.2 mm	4 mm	0.75 mm	2	3 mm	38 mm	BEFM-008-400	34.60	BEFM-008-400K	38.85
0.8 mm	.0315		1.2 mm	7 mm	0.75 mm	2	3 mm	38 mm	BEFM-008-700	35.70	BEFM-008-700K	39.95
0.8 mm	.0315		1.2 mm	9 mm	0.75 mm	2	3 mm	38 mm	BEFM-008-900	39.10		
.0350	.0350		.053	.150	.033	2	.1250	1.5	BEF-035-150	34.60	BEF-035-150K	38.85
.0350	.0350		.053	.150	.033	3	.1250	1.5	BEF-035-150-3	34.60	BEF-035-150-3K	38.85
.0350	.0350		.053	.250	.033	2	.1250	1.5	BEF-035-250	35.70	BEF-035-250K	39.95
.0350	.0350		.053	.250	.033	3	.1250	1.5	BEF-035-250-3	35.70	BEF-035-250-3K	39.95
.0350	.0350		.053	.400	.033	2	.1250	1.5	BEF-035-400	39.10	BEF-035-400K	43.35
.0350	.0350		.053	.400	.033	3	.1250	1.5	BEF-035-400-3	39.10	BEF-035-400-3K	43.35
.0400	.0400		.060	.150	.038	2	.1250	1.5			BEF-040-150K	38.85
.0400	.0400		.060	.150	.038	3	.1250	1.5	BEF-040-150-3	34.60	BEF-040-150-3K	38.85
.0400	.0400		.060	.250	.038	2	.1250	1.5	BEF-040-250	35.70	BEF-040-250K	39.95
.0400	.0400		.060	.250	.038	3	.1250	1.5			BEF-040-250-3K	39.95
.0400	.0400		.060	.500	.038	2	.1250	1.5			BEF-040-500K	45.65
.0400	.0400		.060	.500	.038	3	.1250	1.5	BEF-040-500-3	41.40	BEF-040-500-3K	45.65
.0450	.0450		.068	.150	.043	2	.1250	1.5	BEF-045-150	34.60	BEF-045-150K	38.85
.0450	.0450		.068	.150	.043	3	.1250	1.5	BEF-045-150-3	34.60	BEF-045-150-3K	38.85
.0450	.0450		.068	.250	.043	2	.1250	1.5	BEF-045-250	35.70	BEF-045-250K	39.95
.0450	.0450		.068	.250	.043	3	.1250	1.5	BEF-045-250-3	35.70	BEF-045-250-3K	39.95
.0450	.0450		.068	.500	.043	2	.1250	1.5	BEF-045-500	41.40	BEF-045-500K	45.65
.0450	.0450		.068	.500	.043	3	.1250	1.5	BEF-045-500-3	41.40	BEF-045-500-3K	45.65
.0469	.0469		.071	.150	.045	2	.1250	1.5	BEF-047-150	34.60		
.0469	.0469		.071	.150	.045	3	.1250	1.5			BEF-047-150-3K	38.85
.0469	.0469		.071	.250	.045	2	.1250	1.5	BEF-047-250	35.70	BEF-047-250K	39.95
.0469	.0469		.071	.250	.045	3	.1250	1.5	BEF-047-250-3	35.70		
.0469	.0469		.071	.500	.045	2	.1250	1.5			BEF-047-500K	45.65
.0469	.0469		.071	.500	.045	3	.1250	1.5	BEF-047-500-3	41.40	BEF-047-500-3K	45.65
1.2 mm	.0472		1.8 mm	10 mm	1.1 mm	2	3 mm	38 mm			BEFM-012-1000K	43.35
1.2 mm	.0472		1.8 mm	12 mm	1.1 mm	2	3 mm	38 mm	BEFM-012-1200	42.90	BEFM-012-1200K	47.10
.0500	.0500		.075	.200	.048	2	.1250	1.5	BEF-050-200	34.60	BEF-050-200K	38.85
.0500	.0500		.075	.200	.048	3	.1250	1.5	BEF-050-200-3	34.60	BEF-050-200-3K	38.85
.0500	.0500		.075	.300	.048	2	.1250	1.5	BEF-050-300	35.70	BEF-050-300K	39.95
.0500	.0500		.075	.300	.048	3	.1250	1.5	BEF-050-300-3	35.70	BEF-050-300-3K	39.95
.0500	.0500		.075	.550	.048	2	.1250	1.5			BEF-050-550K	45.65
.0500	.0500		.075	.550	.048	3	.1250	1.5	BEF-050-550-3	41.40	BEF-050-550-3K	45.65
1.5 mm	.0591		2.2 mm	6 mm	1.4 mm	2	3 mm	38 mm	BEFM-015-600	35.70	BEFM-015-600K	39.95
1.5 mm	.0591		2.2 mm	10 mm	1.4 mm	2	3 mm	38 mm	BEFM-015-1000	39.10	BEFM-015-1000K	43.35
1.5 mm	.0591		2.2 mm	12 mm	1.4 mm	2	3 mm	38 mm	BEFM-015-1200	42.90	BEFM-015-1200K	47.10
1.5 mm	.0591		2.2 mm	15 mm	1.4 mm	2	3 mm	38 mm	BEFM-015-1500	45.40	BEFM-015-1500K	49.65
1.5 mm	.0591		2.2 mm	20 mm	1.4 mm	2	3 mm	50 mm	BEFM-015-2000	56.70	BEFM-015-2000K	60.95

*.0005" / .013 mm max TIR

Continued on next page

BEF / BEFM

End Mills For Steels & High Temp Alloys
Ball – 2 & 3 Flute – Long Reach, Stub Flute (cont.)

Continued from previous page

Cutter Diameter*			Length of Cut	Overall Reach	Neck Dia.	Flutes	Shank Dia.	Overall Length	Uncoated		nACRo® Coated	
D1			L2	L3	D3	D2 (h6)	L1		Tool #	Price	Tool #	Price
+ .0000"	+ .000 mm	decimal equiv.	+ .015"	+ .010"								
-.0005"	-.013 mm		+ .38 mm	-.000"								
			-.00 mm	-.00 mm								
.0600	.0600	.0600	.090	.200	.056	2	.1250	1.5	BEF-060-200	34.60	BEF-060-200K	38.85
.0600	.0600	.0600	.090	.200	.056	3	.1250	1.5	BEF-060-200-3	34.60	BEF-060-200-3K	38.85
.0600	.0600	.0600	.090	.350	.056	2	.1250	1.5	BEF-060-350	35.70	BEF-060-350K	39.95
.0600	.0600	.0600	.090	.350	.056	3	.1250	1.5			BEF-060-350-3K	39.95
.0600	.0600	.0600	.090	.500	.056	2	.1250	1.5	BEF-060-500	41.40	BEF-060-500K	45.65
.0600	.0600	.0600	.090	.500	.056	3	.1250	1.5	BEF-060-500-3	41.40	BEF-060-500-3K	45.65
.0600	.0600	.0600	.090	.750	.056	2	.1250	2.0	BEF-060-750	47.05		
.0600	.0600	.0600	.090	.750	.056	3	.1250	2.0	BEF-060-750-3	47.05	BEF-060-750-3K	51.30
.0625	.0625	.0625	.093	.200	.058	2	.1250	1.5			BEF-062-200K	38.85
.0625	.0625	.0625	.093	.200	.058	3	.1250	1.5	BEF-062-200-3	34.60		
.0625	.0625	.0625	.093	.550	.058	2	.1250	1.5	BEF-062-550	41.40	BEF-062-550K	45.65
.0625	.0625	.0625	.093	.550	.058	3	.1250	1.5	BEF-062-550-3	41.40	BEF-062-550-3K	45.65
.0625	.0625	.0625	.093	.750	.058	2	.1250	2.0	BEF-062-750	47.05	BEF-062-750K	51.30
.0750	.0750	.0750	.113	.250	.071	2	.1250	1.5	BEF-075-250	34.60	BEF-075-250K	38.85
.0750	.0750	.0750	.113	.250	.071	3	.1250	1.5	BEF-075-250-3	34.60	BEF-075-250-3K	38.85
.0750	.0750	.0750	.113	.400	.071	2	.1250	1.5	BEF-075-400	41.40	BEF-075-400K	45.65
.0750	.0750	.0750	.113	.400	.071	3	.1250	1.5	BEF-075-400-3	41.40	BEF-075-400-3K	45.65
.0750	.0750	.0750	.113	.600	.071	2	.1250	2.0	BEF-075-600	45.95	BEF-075-600K	50.20
.0750	.0750	.0750	.113	.600	.071	3	.1250	2.0	BEF-075-600-3	45.95	BEF-075-600-3K	50.20
.0750	.0750	.0750	.113	.900	.071	2	.1250	2.0	BEF-075-900	49.60	BEF-075-900K	53.85
.0750	.0750	.0750	.113	.900	.071	3	.1250	2.0	BEF-075-900-3	49.60	BEF-075-900-3K	53.85
.0781	.0781	.0781	.117	.250	.074	2	.1250	1.5	BEF-078-250	34.60		
.0781	.0781	.0781	.117	.250	.074	3	.1250	1.5			BEF-078-250-3K	38.85
.0781	.0781	.0781	.117	.400	.074	2	.1250	1.5	BEF-078-400	41.40	BEF-078-400K	45.65
.0781	.0781	.0781	.117	.400	.074	3	.1250	1.5	BEF-078-400-3	41.40	BEF-078-400-3K	45.65
.0781	.0781	.0781	.117	.650	.074	2	.1250	2.0	BEF-078-650	45.95	BEF-078-650K	50.20
.0781	.0781	.0781	.117	.650	.074	3	.1250	2.0	BEF-078-650-3	45.95	BEF-078-650-3K	50.20
.0781	.0781	.0781	.117	.900	.074	2	.1250	2.0	BEF-078-900	49.60	BEF-078-900K	53.85
.0781	.0781	.0781	.117	.900	.074	3	.1250	2.0	BEF-078-900-3	49.60	BEF-078-900-3K	53.85
2 mm	.0787		2.5 mm	7 mm	1.9 mm	2	3 mm	38 mm	BEFM-020-700	35.70	BEFM-020-700K	39.95
2 mm	.0787		2.5 mm	16 mm	1.9 mm	2	3 mm	38 mm	BEFM-020-1600	45.40		
2 mm	.0787		2.5 mm	20 mm	1.9 mm	2	3 mm	50 mm	BEFM-020-2000	56.70	BEFM-020-2000K	60.95
2 mm	.0787		2.5 mm	25 mm	1.9 mm	2	3 mm	50 mm	BEFM-020-2500	62.95	BEFM-020-2500K	67.20
.0900	.0900	.0900	.125	.250	.086	2	.1250	1.5	BEF-090-250	34.60	BEF-090-250K	38.85
.0900	.0900	.0900	.125	.400	.086	2	.1250	1.5	BEF-090-400	41.40	BEF-090-400K	45.65
.0900	.0900	.0900	.125	.400	.086	3	.1250	1.5	BEF-090-400-3	41.40		
.0900	.0900	.0900	.125	.400	.086	3	.1250	1.5			BEF-090-400-3K	45.65
.0900	.0900	.0900	.125	.650	.086	2	.1250	2.0	BEF-090-650	45.95		
.0900	.0900	.0900	.125	.650	.086	3	.1250	2.0	BEF-090-650-3	45.95		
.0900	.0900	.0900	.125	.650	.086	3	.1250	2.0			BEF-090-650-3K	50.20
.0900	.0900	.0900	.125	.900	.086	2	.1250	2.0	BEF-090-900	47.05	BEF-090-900K	51.30

*.0005" / .013 mm max TIR

Continued on next page

Steels & High Temp. Alloys

End Mills For Steels & High Temp Alloys

Ball – 2 & 3 Flute – Long Reach, Stub Flute (cont.)

BEF / BEFM

Continued from previous page

Steels & High Temp. Alloys

Cutter Diameter*			Length of Cut	Overall Reach	Neck Dia.	Flutes	Shank Dia.	Overall Length	Uncoated		nACRo® Coated	
D1 +.0000" -.0005"	+ .000 mm -.013 mm	decimal equiv.	L2 +.015" -.000"	L3 +.010" -.000"	D3 +.25 mm -.00 mm	D2 (h6)	L1	Tool #	Price	Tool #	Price	
.0938	.0938	.0938	.125	.250	.089	2	.1250	1.5	BEF-093-250	34.60	BEF-093-250K	38.85
.0938	.0938	.0938	.125	.500	.089	2	.1250	1.5	BEF-093-500	41.40	BEF-093-500K	45.65
.0938	.0938	.0938	.125	.750	.089	2	.1250	2.0	BEF-093-750	47.05	BEF-093-750K	51.30
.0938	.0938	.0938	.125	1.000	.089	2	.1250	2.0	BEF-093-1000	49.60	BEF-093-1000K	53.85
2.5 mm	.0984	.0984	3 mm	10 mm	2.4 mm	2	3 mm	38 mm	BEFM-025-1000	39.10	BEFM-025-1000K	43.35
2.5 mm	.0984	.0984	3 mm	15 mm	2.4 mm	2	3 mm	38 mm	BEFM-025-1500	45.40	BEFM-025-1500K	49.65
2.5 mm	.0984	.0984	3 mm	20 mm	2.4 mm	2	3 mm	50 mm			BEFM-025-2000K	60.95
2.5 mm	.0984	.0984	3 mm	25 mm	2.4 mm	2	3 mm	50 mm	BEFM-025-2500	62.95	BEFM-025-2500K	67.20
2.5 mm	.0984	.0984	3 mm	30 mm	2.4 mm	2	3 mm	60 mm	BEFM-025-3000	69.15	BEFM-025-3000K	73.65
3 mm	.1181	.1181	3 mm	10 mm	2.9 mm	2	6 mm	57 mm	BEFM-030-1000	48.90		
3 mm	.1181	.1181	3 mm	15 mm	2.9 mm	2	6 mm	57 mm	BEFM-030-1500	56.00		
3 mm	.1181	.1181	3 mm	25 mm	2.9 mm	2	6 mm	57 mm	BEFM-030-2500	64.10		
3 mm	.1181	.1181	3 mm	30 mm	2.9 mm	2	6 mm	57 mm	BEFM-030-3000	70.35	BEFM-030-3000K	75.30
.1250	.1250	.1250	.125	.375	.121	2	.1875	2.0	BEF-125-375	41.40	BEF-125-375K	46.15
.1250	.1250	.1250	.125	.750	.121	2	.1875	2.0	BEF-125-750	47.05	BEF-125-750K	51.85
.1250	.1250	.1250	.125	1.000	.121	2	.1875	2.0	BEF-125-1000	49.60	BEF-125-1000K	54.40
.1250	.1250	.1250	.125	1.500	.121	2	.1875	3.0	BEF-125-1500	53.25	BEF-125-1500K	58.35
4 mm	.1575	.1575	5 mm	15 mm	3.9 mm	2	6 mm	57 mm	BEFM-040-1500	56.00	BEFM-040-1500K	61.15
4 mm	.1575	.1575	5 mm	25 mm	3.9 mm	2	6 mm	57 mm	BEFM-040-2500	64.10	BEFM-040-2500K	69.15
4 mm	.1575	.1575	5 mm	30 mm	3.9 mm	2	6 mm	57 mm	BEFM-040-3000	70.35	BEFM-040-3000K	75.30
.1875	.1875	.1875	.200	.750	.183	2	.2500	2.5	BEF-187-750	46.45		
.1875	.1875	.1875	.200	1.000	.183	2	.2500	2.5	BEF-187-1000	54.40		
.1875	.1875	.1875	.200	1.500	.183	2	.2500	3.0			BEF-187-1500K	68.40
5 mm	.1969	.1969	6 mm	15 mm	4.9 mm	2	6 mm	57 mm	BEFM-050-1500	56.00	BEFM-050-1500K	61.15
5 mm	.1969	.1969	6 mm	25 mm	4.9 mm	2	6 mm	57 mm	BEFM-050-2500	64.10	BEFM-050-2500K	69.15
5 mm	.1969	.1969	6 mm	30 mm	4.9 mm	2	6 mm	57 mm	BEFM-050-3000	70.35	BEFM-050-3000K	75.30
D1 +.0000" -.0010"	decimal equiv.	L2 +.015" -.000"	L3 +.010" -.000"	D3	D2 (h6)	L1	Tool #	Price	Tool #	Price		
.2500	.2500	.250	.500	.246	2	.2500	2.5	BEF-250-500	39.45	BEF-250-500K	45.55	
.2500	.2500	.250	.750	.246	2	.2500	2.5	BEF-250-750	46.45	BEF-250-750K	52.50	
.2500	.2500	.250	1.000	.246	2	.2500	2.5	BEF-250-1000	54.40	BEF-250-1000K	60.45	
.2500	.2500	.250	1.500	.246	2	.2500	3.0	BEF-250-1500	62.35	BEF-250-1500K	68.40	

*.0005" / .013 mm max TIR

MEF / MEFM

End Mills For Steels & High Temp Alloys
Corner Radius – 2 & 3 Flute – Stub Flute

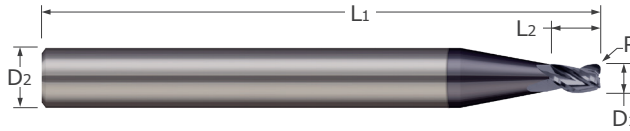

- Designed for high performance in titanium alloys, inconel, nickel alloys, and other high-temperature materials with outstanding performance in difficult-to-machine steels, stainless steels, and tool steels
- Stub flutes for maximum rigidity
- Corner radius profile ■ 20° helix ■ Center cutting
- nACRo® coating option for added heat resistance in difficult to machine materials
- Solid carbide ■ CNC ground in the USA

Cutter Diameter*			Length of Cut	Corner Radius	Flutes	Shank Diameter	Overall Length	Uncoated		nACRo® Coated	
D1			L2	R		D2 (h6)	L1	Tool #	Price	Tool #	Price
+ .0000" - .0005"	+ .000 mm - .013 mm	decimal equiv.	+ .015" - .000" + .38 mm - .00 mm	+ .0000" - .0005" + .000 mm - .013 mm							
.0150		.0150	.023	.002	2	.1250	1.5			MEF-015-023-002K	48.75
.0150		.0150	.023	.002	3	.1250	1.5	MEF-015-023-3-002	44.50	MEF-015-023-3-002K	48.75
	0.5 mm	.0197	0.7 mm	0.05 mm	2	3 mm	38 mm	MEFM-005-070-05	31.50	MEFM-005-070-05K	35.70
.0200		.0200	.030	.002	2	.1250	1.5	MEF-020-030-002	31.50	MEF-020-030-002K	35.70
.0200		.0200	.030	.002	3	.1250	1.5			MEF-020-030-3-002K	35.70
.0250		.0250	.038	.003	2	.1250	1.5	MEF-025-038-003	31.50	MEF-025-038-003K	35.70
.0250		.0250	.038	.003	3	.1250	1.5	MEF-025-038-3-003	31.50	MEF-025-038-3-003K	35.70
.0300		.0300	.045	.005	2	.1250	1.5	MEF-030-045-005	28.95	MEF-030-045-005K	33.20
.0300		.0300	.045	.005	3	.1250	1.5	MEF-030-045-3-005	28.95		
.0300		.0300	.045	.010	2	.1250	1.5	MEF-030-045-010	28.95	MEF-030-045-010K	33.20
.0300		.0300	.045	.010	3	.1250	1.5			MEF-030-045-3-010K	33.20
.0313		.0313	.047	.005	2	.1250	1.5	MEF-031-047-005	28.95	MEF-031-047-005K	33.20
.0313		.0313	.047	.005	3	.1250	1.5	MEF-031-047-3-005	28.95		
.0313		.0313	.047	.010	3	.1250	1.5	MEF-031-047-3-010	28.95	MEF-031-047-3-010K	33.20
	0.8 mm	.0315	1.2 mm	0.05 mm	2	3 mm	38 mm	MEFM-008-120-05	28.95	MEFM-008-120-05K	33.20
.0350		.0350	.053	.005	2	.1250	1.5	MEF-035-053-005	28.95	MEF-035-053-005K	33.20
.0350		.0350	.053	.005	3	.1250	1.5	MEF-035-053-3-005	28.95	MEF-035-053-3-005K	33.20
.0350		.0350	.053	.010	2	.1250	1.5	MEF-035-053-010	28.95	MEF-035-053-010K	33.20
.0350		.0350	.053	.010	3	.1250	1.5	MEF-035-053-3-010	28.95	MEF-035-053-3-010K	33.20
	1 mm	.0394	1.5 mm	0.1 mm	2	3 mm	38 mm	MEFM-010-150-10	28.95	MEFM-010-150-10K	33.20
	1 mm	.0394	1.5 mm	0.2 mm	2	3 mm	38 mm	MEFM-010-150-20	28.95	MEFM-010-150-20K	33.20
.0400		.0400	.060	.005	2	.1250	1.5	MEF-040-060-005	28.95	MEF-040-060-005K	33.20
.0400		.0400	.060	.010	2	.1250	1.5	MEF-040-060-010	28.95	MEF-040-060-010K	33.20
.0400		.0400	.060	.010	3	.1250	1.5	MEF-040-060-3-010	28.95	MEF-040-060-3-010K	33.20
.0450		.0450	.068	.005	2	.1250	1.5	MEF-045-068-005	28.95	MEF-045-068-005K	33.20
.0450		.0450	.068	.005	3	.1250	1.5	MEF-045-068-3-005	28.95	MEF-045-068-3-005K	33.20
.0450		.0450	.068	.010	2	.1250	1.5	MEF-045-068-010	28.95	MEF-045-068-010K	33.20
.0450		.0450	.068	.010	3	.1250	1.5	MEF-045-068-3-010	28.95	MEF-045-068-3-010K	33.20
.0469		.0469	.071	.005	2	.1250	1.5	MEF-047-071-005	28.95	MEF-047-071-005K	33.20
.0469		.0469	.071	.005	3	.1250	1.5	MEF-047-071-3-005	28.95	MEF-047-071-3-005K	33.20

*.0005" / .013 mm max TIR

Continued on next page

End Mills For Steels & High Temp Alloys

Corner Radius – 2 & 3 Flute – Stub Flute (cont.)

MEF / MEFM

Continued from previous page

Steels & High Temp. Alloys

Cutter Diameter*			Length of Cut	Corner Radius	Flutes	Shank Diameter	Overall Length	Uncoated		nACRo® Coated	
D1 +.0000" -.0005"	+.000 mm -.013 mm	decimal equiv.	L2 +.015" -.000" +.38 mm -.00 mm	R +.0000" -.0005" +.000 mm -.013 mm		D2 (h6)	L1	Tool #	Price	Tool #	Price
.0469		.0469	.071	.010	2	.1250	1.5	MEF-047-071-010	28.95	MEF-047-071-010K	33.20
.0469		.0469	.071	.010	3	.1250	1.5	MEF-047-071-3-010	28.95		
	1.2 mm	.0472	1.8 mm	0.1 mm	2	3 mm	38 mm	MEFM-012-180-10	28.95	MEFM-012-180-10K	33.20
	1.2 mm	.0472	1.8 mm	0.2 mm	2	3 mm	38 mm	MEFM-012-180-20	28.95	MEFM-012-180-20K	33.20
.0500		.0500	.075	.005	2	.1250	1.5	MEF-050-075-005	28.95	MEF-050-075-005K	33.20
.0500		.0500	.075	.005	3	.1250	1.5	MEF-050-075-3-005	28.95	MEF-050-075-3-005K	33.20
.0500		.0500	.075	.010	2	.1250	1.5	MEF-050-075-010	28.95	MEF-050-075-010K	33.20
.0500		.0500	.075	.010	3	.1250	1.5			MEF-050-075-3-010K	33.20
	1.5 mm	.0591	2.2 mm	0.15 mm	2	3 mm	38 mm	MEFM-015-220-15	28.95		
	1.5 mm	.0591	2.2 mm	0.25 mm	2	3 mm	38 mm	MEFM-015-220-25	28.95	MEFM-015-220-25K	33.20
.0600		.0600	.090	.005	2	.1250	1.5	MEF-060-090-005	28.95	MEF-060-090-005K	33.20
.0600		.0600	.090	.005	3	.1250	1.5	MEF-060-090-3-005	28.95	MEF-060-090-3-005K	33.20
.0600		.0600	.090	.010	2	.1250	1.5	MEF-060-090-010	28.95		
.0600		.0600	.090	.010	3	.1250	1.5	MEF-060-090-3-010	28.95	MEF-060-090-3-010K	33.20
.0600		.0600	.090	.015	2	.1250	1.5	MEF-060-090-015	28.95	MEF-060-090-015K	33.20
.0600		.0600	.090	.015	3	.1250	1.5	MEF-060-090-3-015	28.95		
.0625		.0625	.093	.005	2	.1250	1.5	MEF-062-093-005	28.95	MEF-062-093-005K	33.20
.0625		.0625	.093	.005	3	.1250	1.5	MEF-062-093-3-005	28.95		
.0625		.0625	.093	.010	2	.1250	1.5	MEF-062-093-010	28.95	MEF-062-093-010K	33.20
.0625		.0625	.093	.010	3	.1250	1.5	MEF-062-093-3-010	28.95		
.0625		.0625	.093	.015	2	.1250	1.5	MEF-062-093-015	28.95	MEF-062-093-015K	33.20
.0750		.0750	.113	.005	2	.1250	1.5	MEF-075-113-005	28.95	MEF-075-113-005K	33.20
.0750		.0750	.113	.005	3	.1250	1.5	MEF-075-113-3-005	28.95	MEF-075-113-3-005K	33.20
.0750		.0750	.113	.010	2	.1250	1.5	MEF-075-113-010	28.95	MEF-075-113-010K	33.20
.0750		.0750	.113	.010	3	.1250	1.5	MEF-075-113-3-010	28.95	MEF-075-113-3-010K	33.20
.0750		.0750	.113	.015	2	.1250	1.5	MEF-075-113-015	28.95	MEF-075-113-015K	33.20
.0750		.0750	.113	.015	3	.1250	1.5	MEF-075-113-3-015	28.95	MEF-075-113-3-015K	33.20
.0781		.0781	.117	.005	2	.1250	1.5	MEF-078-117-005	28.95	MEF-078-117-005K	33.20
.0781		.0781	.117	.005	3	.1250	1.5	MEF-078-117-3-005	28.95	MEF-078-117-3-005K	33.20
.0781		.0781	.117	.010	2	.1250	1.5	MEF-078-117-010	28.95		
.0781		.0781	.117	.015	2	.1250	1.5	MEF-078-117-015	28.95	MEF-078-117-015K	33.20
.0781		.0781	.117	.015	3	.1250	1.5	MEF-078-117-3-015	28.95	MEF-078-117-3-015K	33.20
	2 mm	.0787	2.5 mm	0.15 mm	2	3 mm	38 mm	MEFM-020-250-15	28.95		
	2 mm	.0787	2.5 mm	0.25 mm	2	3 mm	38 mm	MEFM-020-250-25	28.95	MEFM-020-250-25K	33.20
.0900		.0900	.125	.005	2	.1250	1.5	MEF-090-125-005	28.95	MEF-090-125-005K	33.20
.0900		.0900	.125	.010	2	.1250	1.5	MEF-090-125-010	28.95	MEF-090-125-010K	33.20
.0900		.0900	.125	.015	2	.1250	1.5			MEF-090-125-015K	33.20
.0938		.0938	.125	.005	2	.1250	1.5	MEF-093-125-005	28.95		
.0938		.0938	.125	.010	2	.1250	1.5	MEF-093-125-010	28.95	MEF-093-125-010K	33.20
	3 mm	.1181	3 mm	0.15 mm	2	6 mm	57 mm			MEFM-030-300-15K	47.95
	3 mm	.1181	3 mm	0.25 mm	2	6 mm	57 mm	MEFM-030-300-25	41.85	MEFM-030-300-25K	47.95

*.0005" / .013 mm max TIR

Continued on next page

MEF / MEFM

End Mills For Steels & High Temp Alloys
Corner Radius – 2 & 3 Flute – Stub Flute (cont.)

Continued from previous page

Cutter Diameter*			Length of Cut	Corner Radius	Flutes	Shank Diameter	Overall Length	Uncoated		nACRo® Coated	
D1			L2	R		D2 (h6)	L1	Tool #	Price	Tool #	Price
+ .0000" - .0005"	+ .000 mm - .013 mm	decimal equiv.	+ .015" - .000" + .38 mm - .00 mm	+ .0000" - .0005" + .000 mm - .013 mm							
.1250		.1250	.125	.005	2	.1875	2.0	MEF-125-125-005	31.20	MEF-125-125-005K	35.95
.1250		.1250	.125	.010	2	.1875	2.0	MEF-125-125-010	31.20	MEF-125-125-010K	35.95
	4 mm	.1575	5 mm	0.25 mm	2	6 mm	57 mm	MEFM-040-500-25	41.85		
	5 mm	.1969	6 mm	0.25 mm	2	6 mm	57 mm	MEFM-050-600-25	41.85	MEFM-050-600-25K	47.95
D1			L2	R		D2 (h6)	L1	Tool #	Price	Tool #	Price
+ .0000" - .0010"		decimal equiv.	+ .015" - .000"	+ .0000" - .0005"							
.2500		.2500	.250	.005	2	.2500	2.5	MEF-250-250-005	41.85	MEF-250-250-005K	47.95
.2500		.2500	.250	.010	2	.2500	2.5	MEF-250-250-010	41.85	MEF-250-250-010K	47.95
.2500		.2500	.250	.015	2	.2500	2.5	MEF-250-250-015	41.85	MEF-250-250-015K	47.95

*.0005" / .013 mm max TIR

Steels & High Temp. Alloys

Sent Directly to Your Inbox

Valuable information about Micro 100 products and technical resources directly to your inbox. Be the first to know of newly-released tools to gain an immediate leg-up on the competition!

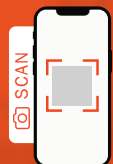
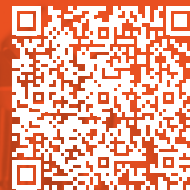

End Mills For Steels & High Temp Alloys

Corner Radius – 2 & 3 Flute – Long Reach, Stub Flute

MEF / MEFM

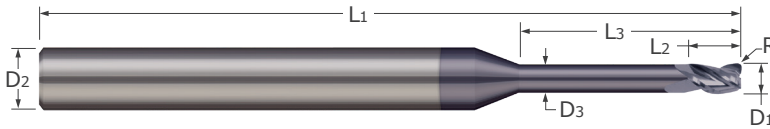

- Designed for high performance in titanium alloys, inconel, nickel alloys, and other high-temperature materials with outstanding performance in difficult-to-machine steels, stainless steels, and tool steels
- Long reach for deep pocket milling
- Stub flutes for maximum rigidity
- Reduced neck diameter to avoid heeling
- Corner radius profile ■ 20° helix ■ Center cutting
- nACRo® coating option for added heat resistance in difficult to machine materials
- Solid carbide ■ CNC ground in the USA

Steels & High Temp. Alloys

Cutter Diameter*	Length of Cut	Corner Radius	Overall Reach	Neck Dia.	Flutes	Shank Dia.	Overall Length	Uncoated		nACRo® Coated	
								Tool #	Price	Tool #	Price
D1 +.0000"/+.000mm -.0005"/-.013mm	L2 +.015" -.000"	R +.0000" -.0005"	L3 +.010" -.010"	D3		D2 (h6)	L1				
.0150 .0150	.023 .002	.100 .014	2 .1250	1.5	MEF-015-100-002	50.20	MEF-015-100-002K	54.45			
.0150 .0150	.023 .002	.100 .014	3 .1250	1.5			MEF-015-100-3-002K	54.45			
.0150 .0150	.023 .002	.200 .014	2 .1250	1.5	MEF-015-200-002	51.30	MEF-015-200-002K	55.55			
.0150 .0150	.023 .002	.200 .014	3 .1250	1.5	MEF-015-200-3-002	51.30	MEF-015-200-3-002K	55.55			
0.5 mm .0197	0.7 mm 0.05 mm	6 mm 0.45 mm	2 3 mm	38 mm	MEFM-005-600-05	39.10	MEFM-005-600-05K	43.35			
.0200 .0200	.030 .002	.150 .019	2 .1250	1.5			MEF-020-150-002K	41.40			
.0200 .0200	.030 .002	.250 .019	2 .1250	1.5	MEF-020-250-002	38.25					
.0200 .0200	.030 .002	.250 .019	3 .1250	1.5			MEF-020-250-3-002K	42.50			
.0200 .0200	.030 .002	.150 .019	3 .1250	1.5			MEF-020-150-3-002K	41.40			
0.6 mm .0236	0.9 mm 0.05 mm	5 mm 0.55 mm	2 3 mm	38 mm	MEFM-006-500-05	38.25	MEFM-006-500-05K	42.50			
0.6 mm .0236	0.9 mm 0.05 mm	6 mm 0.55 mm	2 3 mm	38 mm	MEFM-006-600-05	41.65	MEFM-006-600-05K	45.90			
.0250 .0250	.038 .003	.150 .024	2 .1250	1.5	MEF-025-150-003	37.15	MEF-025-150-003K	41.40			
.0250 .0250	.038 .003	.150 .024	3 .1250	1.5	MEF-025-150-3-003	37.15	MEF-025-150-3-003K	41.40			
.0250 .0250	.038 .003	.250 .024	2 .1250	1.5	MEF-025-250-003	38.25	MEF-025-250-003K	42.50			
.0250 .0250	.038 .003	.250 .024	3 .1250	1.5			MEF-025-250-3-003K	42.50			
.0300 .0300	.045 .005	.100 .028	2 .1250	1.5	MEF-030-100-005	34.60	MEF-030-100-005K	38.85			
.0300 .0300	.045 .005	.100 .028	3 .1250	1.5			MEF-030-100-3-005K	38.85			
.0300 .0300	.045 .005	.200 .028	2 .1250	1.5	MEF-030-200-005	35.70	MEF-030-200-005K	39.95			
.0300 .0300	.045 .005	.375 .028	2 .1250	1.5	MEF-030-375-005	39.10	MEF-030-375-005K	43.35			
.0300 .0300	.045 .005	.375 .028	3 .1250	1.5	MEF-030-375-3-005	39.10	MEF-030-375-3-005K	43.35			
.0300 .0300	.045 .010	.100 .028	2 .1250	1.5	MEF-030-100-010	34.60	MEF-030-100-010K	38.85			
.0300 .0300	.045 .010	.100 .028	3 .1250	1.5	MEF-030-100-3-010	34.60	MEF-030-100-3-010K	38.85			
.0300 .0300	.045 .010	.200 .028	2 .1250	1.5	MEF-030-200-010	35.70	MEF-030-200-010K	39.95			
.0300 .0300	.045 .010	.375 .028	2 .1250	1.5	MEF-030-375-010	39.10	MEF-030-375-010K	43.35			
.0300 .0300	.045 .010	.375 .028	3 .1250	1.5	MEF-030-375-3-010	39.10	MEF-030-375-3-010K	43.35			

*.0005" / .013 mm max TIR

Continued on next page

MEF / MEFM

End Mills For Steels & High Temp Alloys
Corner Radius – 2 & 3 Flute – Long Reach, Stub Flute (cont.)

Continued from previous page

Cutter Diameter*	Length of Cut	Corner Radius	Overall Reach	Neck Dia.	Flutes	Shank Dia.	Overall Length	Uncoated		nACRo® Coated		
								Tool #	Price	Tool #	Price	
D1 +.0000" +.000mm -.0005" -.013mm	L2 +.015" +.0000" -.000" -.0005" +.38mm +.000mm -.00mm -.013mm	R +.010" -.010"	L3 +.25mm -.00mm	D3		D2 (h6)	L1					
.0313	.0313	.047	.005	.100	.029	2	.1250	1.5	MEF-031-100-005	34.60	MEF-031-100-005K	38.85
.0313	.0313	.047	.005	.100	.029	3	.1250	1.5	MEF-031-100-3-005	34.60	MEF-031-100-3-005K	38.85
.0313	.0313	.047	.005	.200	.029	2	.1250	1.5	MEF-031-200-005	35.70	MEF-031-200-005K	39.95
.0313	.0313	.047	.005	.200	.029	3	.1250	1.5	MEF-031-200-3-005	35.70	MEF-031-200-3-005K	39.95
.0313	.0313	.047	.005	.375	.029	2	.1250	1.5	MEF-031-375-005	39.10	MEF-031-375-005K	43.35
.0313	.0313	.047	.005	.375	.029	3	.1250	1.5	MEF-031-375-3-005	39.10	MEF-031-375-3-005K	43.35
.0313	.0313	.047	.010	.100	.029	2	.1250	1.5	MEF-031-100-010	34.60		
.0313	.0313	.047	.010	.100	.029	3	.1250	1.5	MEF-031-100-3-010	34.60	MEF-031-100-3-010K	38.85
.0313	.0313	.047	.010	.200	.029	2	.1250	1.5	MEF-031-200-010	35.70	MEF-031-200-010K	39.95
.0313	.0313	.047	.010	.200	.029	3	.1250	1.5	MEF-031-200-3-010	35.70	MEF-031-200-3-010K	39.95
.0313	.0313	.047	.010	.375	.029	2	.1250	1.5	MEF-031-375-010	39.10	MEF-031-375-010K	43.35
.0313	.0313	.047	.010	.375	.029	3	.1250	1.5	MEF-031-375-3-010	39.10	MEF-031-375-3-010K	43.35
0.8 mm	.0315	1.2 mm	0.05 mm	4 mm	0.75 mm	2	3 mm	38 mm			MEFM-008-400-05K	38.85
0.8 mm	.0315	1.2 mm	0.05 mm	7 mm	0.75 mm	2	3 mm	38 mm	MEFM-008-700-05	38.60	MEFM-008-700-05K	42.80
0.8 mm	.0315	1.2 mm	0.05 mm	9 mm	0.75 mm	2	3 mm	38 mm	MEFM-008-900-05	43.05	MEFM-008-900-05K	47.30
.0350	.0350	.053	.005	.150	.033	2	.1250	1.5	MEF-035-150-005	34.60	MEF-035-150-005K	38.85
.0350	.0350	.053	.005	.150	.033	3	.1250	1.5	MEF-035-150-3-005	34.60	MEF-035-150-3-005K	38.85
.0350	.0350	.053	.005	.250	.033	2	.1250	1.5	MEF-035-250-005	35.70	MEF-035-250-005K	39.95
.0350	.0350	.053	.005	.250	.033	3	.1250	1.5	MEF-035-250-3-005	35.70	MEF-035-250-3-005K	39.95
.0350	.0350	.053	.005	.400	.033	2	.1250	1.5	MEF-035-400-005	39.10	MEF-035-400-005K	43.35
.0350	.0350	.053	.005	.400	.033	3	.1250	1.5	MEF-035-400-3-005	39.10	MEF-035-400-3-005K	43.35
.0350	.0350	.053	.010	.150	.033	2	.1250	1.5	MEF-035-150-010	34.60	MEF-035-150-010K	38.85
.0350	.0350	.053	.010	.150	.033	3	.1250	1.5	MEF-035-150-3-010	34.60		
.0350	.0350	.053	.010	.250	.033	2	.1250	1.5	MEF-035-250-010	35.70	MEF-035-250-010K	39.95
.0350	.0350	.053	.010	.250	.033	3	.1250	1.5	MEF-035-250-3-010	35.70	MEF-035-250-3-010K	39.95
.0350	.0350	.053	.010	.400	.033	2	.1250	1.5	MEF-035-400-010	39.10	MEF-035-400-010K	43.35
.0350	.0350	.053	.010	.400	.033	3	.1250	1.5	MEF-035-400-3-010	39.10	MEF-035-400-3-010K	43.35
1 mm	.0394	1.5 mm	0.1 mm	4 mm	0.95 mm	2	3 mm	38 mm	MEFM-010-400-10	34.60		
1 mm	.0394	1.5 mm	0.2 mm	4 mm	0.95 mm	2	3 mm	38 mm	MEFM-010-400-20	34.60		
1 mm	.0394	1.5 mm	0.2 mm	7 mm	0.95 mm	2	3 mm	38 mm	MEFM-010-700-20	38.60	MEFM-010-700-20K	42.80
1 mm	.0394	1.5 mm	0.2 mm	9 mm	0.95 mm	2	3 mm	38 mm	MEFM-010-900-20	43.00		
.0400	.0400	.060	.005	.150	.038	2	.1250	1.5	MEF-040-150-005	34.60	MEF-040-150-005K	38.85
.0400	.0400	.060	.005	.150	.038	3	.1250	1.5	MEF-040-150-3-005	34.60		
.0400	.0400	.060	.005	.250	.038	2	.1250	1.5	MEF-040-250-005	35.70	MEF-040-250-005K	39.95
.0400	.0400	.060	.005	.250	.038	3	.1250	1.5	MEF-040-250-3-005	35.70	MEF-040-250-3-005K	39.95
.0400	.0400	.060	.005	.500	.038	2	.1250	1.5	MEF-040-500-005	41.40	MEF-040-500-005K	45.65
.0400	.0400	.060	.005	.500	.038	3	.1250	1.5	MEF-040-500-3-005	41.40	MEF-040-500-3-005K	45.65
.0400	.0400	.060	.010	.150	.038	2	.1250	1.5	MEF-040-150-010	34.60	MEF-040-150-010K	38.85
.0400	.0400	.060	.010	.150	.038	3	.1250	1.5	MEF-040-150-3-010	34.60	MEF-040-150-3-010K	38.85
.0400	.0400	.060	.010	.250	.038	2	.1250	1.5	MEF-040-250-010	35.70	MEF-040-250-010K	39.95
.0400	.0400	.060	.010	.250	.038	3	.1250	1.5	MEF-040-250-3-010	35.70	MEF-040-250-3-010K	39.95
.0400	.0400	.060	.010	.500	.038	2	.1250	1.5	MEF-040-500-010	41.40	MEF-040-500-010K	45.65
.0400	.0400	.060	.010	.500	.038	3	.1250	1.5	MEF-040-500-3-010	41.40	MEF-040-500-3-010K	45.65

*.0005" / .013 mm max TIR

Continued on next page

Steels & High Temp. Alloys

End Mills For Steels & High Temp Alloys

Corner Radius – 2 & 3 Flute – Long Reach, Stub Flute (cont.)

MEF / MEFM

Continued from previous page

Steels & High Temp. Alloys

Cutter Diameter*	Length of Cut	Corner Radius	Overall Reach	Neck Dia.	Flutes	Shank Dia.	Overall Length	Uncoated		nACRo® Coated		
								Tool #	Price	Tool #	Price	
D1 +.0000" +.000mm -.0005" -.013mm	L2 +.015" -.000"	R +.0000" -.0005"	L3 +.010" -.010"	D3		D2 (h6)	L1					
.0450	.0450	.068	.005	.150	.043	2	.1250	1.5	MEF-045-150-005	34.60	MEF-045-150-005K	38.85
.0450	.0450	.068	.005	.150	.043	3	.1250	1.5	MEF-045-150-3-005	34.60	MEF-045-150-3-005K	38.85
.0450	.0450	.068	.005	.250	.043	2	.1250	1.5	MEF-045-250-005	35.70	MEF-045-250-005K	39.95
.0450	.0450	.068	.005	.250	.043	3	.1250	1.5	MEF-045-250-3-005	35.70	MEF-045-250-3-005K	39.95
.0450	.0450	.068	.005	.500	.043	2	.1250	1.5	MEF-045-500-005	41.40	MEF-045-500-005K	45.65
.0450	.0450	.068	.005	.500	.043	3	.1250	1.5	MEF-045-500-3-005	41.40	MEF-045-500-3-005K	45.65
.0450	.0450	.068	.010	.150	.043	2	.1250	1.5	MEF-045-150-010	34.60	MEF-045-150-010K	38.85
.0450	.0450	.068	.010	.150	.043	3	.1250	1.5	MEF-045-150-3-010	34.60	MEF-045-150-3-010K	38.85
.0450	.0450	.068	.010	.250	.043	2	.1250	1.5	MEF-045-250-010	35.70	MEF-045-250-010K	39.95
.0450	.0450	.068	.010	.250	.043	3	.1250	1.5	MEF-045-250-3-010	35.70	MEF-045-250-3-010K	39.95
.0450	.0450	.068	.010	.500	.043	2	.1250	1.5	MEF-045-500-010	41.40	MEF-045-500-010K	45.65
.0450	.0450	.068	.010	.500	.043	3	.1250	1.5	MEF-045-500-3-010	41.40	MEF-045-500-3-010K	45.65
.0469	.0469	.071	.005	.150	.045	2	.1250	1.5	MEF-047-150-005	34.60	MEF-047-150-005K	38.85
.0469	.0469	.071	.005	.150	.045	3	.1250	1.5	MEF-047-150-3-005	34.60	MEF-047-150-3-005K	38.85
.0469	.0469	.071	.005	.250	.045	2	.1250	1.5	MEF-047-250-005	35.70	MEF-047-250-005K	39.95
.0469	.0469	.071	.005	.250	.045	3	.1250	1.5			MEF-047-250-3-005K	39.95
.0469	.0469	.071	.005	.500	.045	2	.1250	1.5	MEF-047-500-005	41.40		
.0469	.0469	.071	.005	.500	.045	3	.1250	1.5	MEF-047-500-3-005	41.40	MEF-047-500-3-005K	45.65
.0469	.0469	.071	.010	.150	.045	2	.1250	1.5	MEF-047-150-010	34.60	MEF-047-150-010K	38.85
.0469	.0469	.071	.010	.150	.045	3	.1250	1.5	MEF-047-150-3-010	34.60	MEF-047-150-3-010K	38.85
.0469	.0469	.071	.010	.250	.045	2	.1250	1.5	MEF-047-250-010	35.70	MEF-047-250-010K	39.95
.0469	.0469	.071	.010	.250	.045	3	.1250	1.5	MEF-047-250-3-010	35.70	MEF-047-250-3-010K	39.95
.0469	.0469	.071	.010	.500	.045	2	.1250	1.5	MEF-047-500-010	41.40	MEF-047-500-010K	45.65
.0469	.0469	.071	.010	.500	.045	3	.1250	1.5	MEF-047-500-3-010	41.40	MEF-047-500-3-010K	45.65
1.2 mm	.0472	1.8 mm	0.1 mm	6 mm	1.1 mm	2	3 mm	38 mm	MEFM-012-600-10	38.60		
1.2 mm	.0472	1.8 mm	0.1 mm	10 mm	1.1 mm	2	3 mm	38 mm	MEFM-012-1000-10	43.05	MEFM-012-1000-10K	47.30
1.2 mm	.0472	1.8 mm	0.1 mm	12 mm	1.1 mm	2	3 mm	38 mm	MEFM-012-1200-10	46.80	MEFM-012-1200-10K	51.05
1.2 mm	.0472	1.8 mm	0.2 mm	6 mm	1.1 mm	2	3 mm	38 mm			MEFM-012-600-20K	42.80
1.2 mm	.0472	1.8 mm	0.2 mm	10 mm	1.1 mm	2	3 mm	38 mm	MEFM-012-1000-20	43.05	MEFM-012-1000-20K	47.30
1.2 mm	.0472	1.8 mm	0.2 mm	12 mm	1.1 mm	2	3 mm	38 mm	MEFM-012-1200-20	46.80	MEFM-012-1200-20K	51.05
.0500	.0500	.075	.005	.200	.048	2	.1250	1.5	MEF-050-200-005	34.60	MEF-050-200-005K	38.85
.0500	.0500	.075	.005	.200	.048	3	.1250	1.5	MEF-050-200-3-005	34.60	MEF-050-200-3-005K	38.85
.0500	.0500	.075	.005	.300	.048	2	.1250	1.5	MEF-050-300-005	36.85	MEF-050-300-005K	41.10
.0500	.0500	.075	.005	.300	.048	3	.1250	1.5	MEF-050-300-3-005	36.85	MEF-050-300-3-005K	41.10
.0500	.0500	.075	.005	.550	.048	2	.1250	1.5	MEF-050-550-005	41.40	MEF-050-550-005K	45.65
.0500	.0500	.075	.005	.550	.048	3	.1250	1.5	MEF-050-550-3-005	41.40		
.0500	.0500	.075	.010	.200	.048	2	.1250	1.5	MEF-050-200-010	34.60	MEF-050-200-010K	38.85
.0500	.0500	.075	.010	.200	.048	3	.1250	1.5	MEF-050-200-3-010	34.60	MEF-050-200-3-010K	38.85
.0500	.0500	.075	.010	.300	.048	2	.1250	1.5	MEF-050-300-010	36.85	MEF-050-300-010K	41.10
.0500	.0500	.075	.010	.300	.048	3	.1250	1.5	MEF-050-300-3-010	36.85	MEF-050-300-3-010K	41.10
.0500	.0500	.075	.010	.550	.048	2	.1250	1.5			MEF-050-550-010K	45.65
.0500	.0500	.075	.010	.550	.048	3	.1250	1.5	MEF-050-550-3-010	41.40	MEF-050-550-3-010K	45.65

*.0005" / .013 mm max TIR

Continued on next page

MEF / MEFM

End Mills For Steels & High Temp Alloys
Corner Radius – 2 & 3 Flute – Long Reach, Stub Flute (cont.)

Continued from previous page

Cutter Diameter*	Length of Cut	Corner Radius	Overall Reach	Neck Dia.	Flutes	Shank Dia.	Overall Length	Uncoated		nACRo® Coated	
								Tool #	Price	Tool #	Price
D1 +.0000"+.000mm -.0005"-.013mm	L2 +.015" -.000" +.38mm -.00mm	R +.0000" -.0005" +.000mm -.013mm	L3 +.010" -.010" +.25mm -.00mm	D3		D2 (h6)	L1				
1.5 mm .0591	2.2 mm	0.15 mm	10 mm	1.4 mm	2	3 mm	38 mm	MEFM-015-1000-15	43.05	MEFM-015-1000-15K	47.30
1.5 mm .0591	2.2 mm	0.15 mm	12 mm	1.4 mm	2	3 mm	38 mm	MEFM-015-1200-15	46.80	MEFM-015-1200-15K	51.05
1.5 mm .0591	2.2 mm	0.15 mm	15 mm	1.4 mm	2	3 mm	38 mm	MEFM-015-1500-15	49.35	MEFM-015-1500-15K	53.60
1.5 mm .0591	2.2 mm	0.15 mm	20 mm	1.4 mm	2	3 mm	50 mm	MEFM-015-2000-15	60.70	MEFM-015-2000-15K	64.90
1.5 mm .0591	2.2 mm	0.25 mm	6 mm	1.4 mm	2	3 mm	38 mm	MEFM-015-600-25	38.60		
1.5 mm .0591	2.2 mm	0.25 mm	10 mm	1.4 mm	2	3 mm	38 mm	MEFM-015-1000-25	43.05		
1.5 mm .0591	2.2 mm	0.25 mm	12 mm	1.4 mm	2	3 mm	38 mm	MEFM-015-1200-25	46.80		
1.5 mm .0591	2.2 mm	0.25 mm	15 mm	1.4 mm	2	3 mm	38 mm	MEFM-015-1500-25	49.35	MEFM-015-1500-25K	53.60
1.5 mm .0591	2.2 mm	0.25 mm	20 mm	1.4 mm	2	3 mm	50 mm	MEFM-015-2000-25	60.70	MEFM-015-2000-25K	64.90
.0600 .0600	.090	.005	.200	.056	2	.1250	1.5	MEF-060-200-005	34.60	MEF-060-200-005K	38.85
.0600 .0600	.090	.005	.200	.056	3	.1250	1.5	MEF-060-200-3-005	34.60	MEF-060-200-3-005K	38.85
.0600 .0600	.090	.005	.350	.056	2	.1250	1.5	MEF-060-350-005	36.85	MEF-060-350-005K	41.10
.0600 .0600	.090	.005	.350	.056	3	.1250	1.5	MEF-060-350-3-005	36.85	MEF-060-350-3-005K	41.10
.0600 .0600	.090	.005	.500	.056	2	.1250	1.5	MEF-060-500-005	41.40	MEF-060-500-005K	45.65
.0600 .0600	.090	.005	.500	.056	3	.1250	1.5	MEF-060-500-3-005	41.40	MEF-060-500-3-005K	45.65
.0600 .0600	.090	.005	.750	.056	2	.1250	2.0	MEF-060-750-005	47.05	MEF-060-750-005K	51.30
.0600 .0600	.090	.005	.750	.056	3	.1250	2.0	MEF-060-750-3-005	47.05	MEF-060-750-3-005K	51.30
.0600 .0600	.090	.010	.200	.056	3	.1250	1.5	MEF-060-200-3-010	34.60	MEF-060-200-3-010K	38.85
.0600 .0600	.090	.010	.350	.056	2	.1250	1.5	MEF-060-350-010	36.85	MEF-060-350-010K	41.10
.0600 .0600	.090	.010	.350	.056	3	.1250	1.5	MEF-060-350-3-010	36.85	MEF-060-350-3-010K	41.10
.0600 .0600	.090	.010	.500	.056	2	.1250	1.5	MEF-060-500-010	41.40	MEF-060-500-010K	45.65
.0600 .0600	.090	.010	.500	.056	3	.1250	1.5	MEF-060-500-3-010	41.40	MEF-060-500-3-010K	45.65
.0600 .0600	.090	.010	.750	.056	2	.1250	2.0	MEF-060-750-010	47.05	MEF-060-750-010K	51.30
.0600 .0600	.090	.010	.750	.056	3	.1250	2.0	MEF-060-750-3-010	47.05	MEF-060-750-3-010K	51.30
.0600 .0600	.090	.015	.200	.056	2	.1250	1.5	MEF-060-200-015	34.60	MEF-060-200-015K	38.85
.0600 .0600	.090	.015	.200	.056	3	.1250	1.5	MEF-060-200-3-015	34.60	MEF-060-200-3-015K	38.85
.0600 .0600	.090	.015	.350	.056	2	.1250	1.5	MEF-060-350-015	36.85	MEF-060-350-015K	41.10
.0600 .0600	.090	.015	.350	.056	3	.1250	1.5	MEF-060-350-3-015	36.85	MEF-060-350-3-015K	41.10
.0600 .0600	.090	.015	.500	.056	2	.1250	1.5	MEF-060-500-015	41.40	MEF-060-500-015K	45.65
.0600 .0600	.090	.015	.500	.056	3	.1250	1.5	MEF-060-500-3-015	41.40	MEF-060-500-3-015K	45.65
.0600 .0600	.090	.015	.750	.056	2	.1250	2.0	MEF-060-750-015	47.05	MEF-060-750-015K	51.30
.0600 .0600	.090	.015	.750	.056	3	.1250	2.0	MEF-060-750-3-015	47.05	MEF-060-750-3-015K	51.30
.0625 .0625	.093	.005	.200	.058	2	.1250	1.5	MEF-062-200-005	34.60	MEF-062-200-005K	38.85
.0625 .0625	.093	.005	.200	.058	3	.1250	1.5	MEF-062-200-3-005	34.60	MEF-062-200-3-005K	38.85
.0625 .0625	.093	.005	.350	.058	2	.1250	1.5	MEF-062-350-005	36.85		
.0625 .0625	.093	.005	.350	.058	3	.1250	1.5	MEF-062-350-3-005	36.85	MEF-062-350-3-005K	41.10
.0625 .0625	.093	.005	.550	.058	2	.1250	1.5	MEF-062-550-005	41.40	MEF-062-550-005K	45.65
.0625 .0625	.093	.005	.550	.058	3	.1250	1.5			MEF-062-550-3-005K	45.65
.0625 .0625	.093	.005	.750	.058	2	.1250	2.0	MEF-062-750-005	47.05	MEF-062-750-005K	51.30
.0625 .0625	.093	.005	.750	.058	3	.1250	2.0	MEF-062-750-3-005	47.05	MEF-062-750-3-005K	51.30
.0625 .0625	.093	.010	.200	.058	2	.1250	1.5	MEF-062-200-010	34.60		
.0625 .0625	.093	.010	.200	.058	3	.1250	1.5	MEF-062-200-3-010	34.60	MEF-062-200-3-010K	38.85

*.0005" / .013 mm max TIR

Continued on next page

Steels & High Temp. Alloys

End Mills For Steels & High Temp Alloys

Corner Radius – 2 & 3 Flute – Long Reach, Stub Flute (cont.)

MEF / MEFM

Continued from previous page

Steels & High Temp. Alloys

Cutter Diameter*	Length of Cut	Corner Radius	Overall Reach	Neck Dia.	Flutes	Shank Dia.	Overall Length	Uncoated		nACRo® Coated	
								Tool #	Price	Tool #	Price
D1 +.0000"-.000mm -.0005"-.013mm	L2	R +.0000" -.0005" +.000mm -.013mm	L3 +.010" -.010" +.25mm -.00mm	D3		D2 (h6)	L1				
.0625 .0625	.093	.010	.350	.058	2	.1250	1.5	MEF-062-350-010	36.85	MEF-062-350-010K	41.10
.0625 .0625	.093	.010	.350	.058	3	.1250	1.5	MEF-062-350-3-010	36.85	MEF-062-350-3-010K	41.10
.0625 .0625	.093	.010	.550	.058	2	.1250	1.5	MEF-062-550-010	41.40	MEF-062-550-010K	45.65
.0625 .0625	.093	.010	.550	.058	3	.1250	1.5	MEF-062-550-3-010	41.40		
.0625 .0625	.093	.010	.750	.058	2	.1250	2.0	MEF-062-750-010	47.05	MEF-062-750-010K	51.30
.0625 .0625	.093	.010	.750	.058	3	.1250	2.0	MEF-062-750-3-010	47.05	MEF-062-750-3-010K	51.30
.0625 .0625	.093	.015	.200	.058	2	.1250	1.5	MEF-062-200-015	34.60	MEF-062-200-015K	38.85
.0625 .0625	.093	.015	.200	.058	3	.1250	1.5	MEF-062-200-3-015	34.60	MEF-062-200-3-015K	38.85
.0625 .0625	.093	.015	.350	.058	2	.1250	1.5	MEF-062-350-015	36.30	MEF-062-350-015K	40.55
.0625 .0625	.093	.015	.350	.058	3	.1250	1.5	MEF-062-350-3-015	36.30	MEF-062-350-3-015K	40.55
.0625 .0625	.093	.015	.550	.058	2	.1250	1.5	MEF-062-550-015	41.40	MEF-062-550-015K	45.65
.0625 .0625	.093	.015	.550	.058	3	.1250	1.5	MEF-062-550-3-015	41.40	MEF-062-550-3-015K	45.65
.0625 .0625	.093	.015	.750	.058	2	.1250	2.0	MEF-062-750-015	47.05	MEF-062-750-015K	51.30
.0625 .0625	.093	.015	.750	.058	3	.1250	2.0	MEF-062-750-3-015	47.05	MEF-062-750-3-015K	51.30
.0750 .0750	.113	.005	.250	.071	2	.1250	1.5	MEF-075-250-005	34.60	MEF-075-250-005K	38.85
.0750 .0750	.113	.005	.250	.071	3	.1250	1.5	MEF-075-250-3-005	34.60	MEF-075-250-3-005K	38.85
.0750 .0750	.113	.005	.400	.071	2	.1250	1.5	MEF-075-400-005	36.85	MEF-075-400-005K	41.10
.0750 .0750	.113	.005	.400	.071	3	.1250	1.5	MEF-075-400-3-005	36.85	MEF-075-400-3-005K	41.10
.0750 .0750	.113	.005	.600	.071	2	.1250	2.0	MEF-075-600-005	41.40	MEF-075-600-005K	45.65
.0750 .0750	.113	.005	.600	.071	3	.1250	2.0	MEF-075-600-3-005	41.40	MEF-075-600-3-005K	45.65
.0750 .0750	.113	.005	.900	.071	2	.1250	2.0	MEF-075-900-005	49.60	MEF-075-900-005K	53.85
.0750 .0750	.113	.005	.900	.071	3	.1250	2.0	MEF-075-900-3-005	49.60	MEF-075-900-3-005K	53.85
.0750 .0750	.113	.010	.250	.071	2	.1250	1.5	MEF-075-250-010	34.60	MEF-075-250-010K	38.85
.0750 .0750	.113	.010	.250	.071	3	.1250	1.5	MEF-075-250-3-010	34.60	MEF-075-250-3-010K	38.85
.0750 .0750	.113	.010	.400	.071	2	.1250	1.5	MEF-075-400-010	36.85	MEF-075-400-010K	41.10
.0750 .0750	.113	.010	.400	.071	3	.1250	1.5	MEF-075-400-3-010	36.85	MEF-075-400-3-010K	41.10
.0750 .0750	.113	.010	.600	.071	2	.1250	2.0	MEF-075-600-010	41.40	MEF-075-600-010K	45.65
.0750 .0750	.113	.010	.600	.071	3	.1250	2.0	MEF-075-600-3-010	41.40	MEF-075-600-3-010K	45.65
.0750 .0750	.113	.010	.900	.071	2	.1250	2.0	MEF-075-900-010	49.60	MEF-075-900-010K	53.85
.0750 .0750	.113	.010	.900	.071	3	.1250	2.0	MEF-075-900-3-010	49.60	MEF-075-900-3-010K	53.85
.0750 .0750	.113	.015	.250	.071	2	.1250	1.5	MEF-075-250-015	34.60	MEF-075-250-015K	38.85
.0750 .0750	.113	.015	.250	.071	3	.1250	1.5	MEF-075-250-3-015	34.60	MEF-075-250-3-015K	38.85
.0750 .0750	.113	.015	.400	.071	2	.1250	1.5	MEF-075-400-015	36.85	MEF-075-400-015K	41.10
.0750 .0750	.113	.015	.400	.071	3	.1250	1.5	MEF-075-400-3-015	36.85	MEF-075-400-3-015K	41.10
.0750 .0750	.113	.015	.600	.071	2	.1250	2.0	MEF-075-600-015	41.40	MEF-075-600-015K	45.65
.0750 .0750	.113	.015	.600	.071	3	.1250	2.0	MEF-075-600-3-015	41.40	MEF-075-600-3-015K	45.65
.0750 .0750	.113	.015	.900	.071	2	.1250	2.0	MEF-075-900-015	49.60	MEF-075-900-015K	53.85
.0750 .0750	.113	.015	.900	.071	3	.1250	2.0	MEF-075-900-3-015	49.60	MEF-075-900-3-015K	53.85
.0781 .0781	.117	.005	.250	.074	2	.1250	1.5	MEF-078-250-005	34.60	MEF-078-250-005K	38.85
.0781 .0781	.117	.005	.250	.074	3	.1250	1.5	MEF-078-250-3-005	34.60	MEF-078-250-3-005K	38.85
.0781 .0781	.117	.005	.400	.074	2	.1250	1.5	MEF-078-400-005	36.85	MEF-078-400-005K	41.10
.0781 .0781	.117	.005	.400	.074	3	.1250	1.5	MEF-078-400-3-005	36.85	MEF-078-400-3-005K	41.10
.0781 .0781	.117	.005	.650	.074	2	.1250	2.0	MEF-078-650-005	41.40	MEF-078-650-005K	45.65
.0781 .0781	.117	.005	.650	.074	3	.1250	2.0	MEF-078-650-3-005	41.40	MEF-078-650-3-005K	45.65
.0781 .0781	.117	.005	.900	.074	2	.1250	2.0	MEF-078-900-005	49.60	MEF-078-900-005K	53.85

*.0005" / .013 mm max TIR

Continued on next page

MEF / MEFM

End Mills For Steels & High Temp Alloys

Corner Radius – 2 & 3 Flute – Long Reach, Stub Flute (cont.)

Continued from previous page

Cutter Diameter*	Length of Cut	Corner Radius	Overall Reach	Neck Dia.	Flutes	Shank Dia.	Overall Length	Uncoated		nACRo® Coated		
								Tool #	Price	Tool #	Price	
D1 +.0000" +.000mm -.0005" -.013mm	L2 +.015" +.38mm -.000" -.00mm	R +.0000" +.000mm -.0005" -.013mm	L3 +.010" +.25mm -.010" -.00mm	D3		D2 (h6)	L1					
.0781	.0781	.117	.005	.250	.074	3	.1250	2.0	MEF-078-900-3-005	49.60	MEF-078-900-3-005K	53.85
.0781	.0781	.117	.010	.250	.074	2	.1250	1.5	MEF-078-250-010	34.60	MEF-078-250-010K	38.85
.0781	.0781	.117	.010	.250	.074	3	.1250	1.5	MEF-078-250-3-010	34.60	MEF-078-250-3-010K	38.85
.0781	.0781	.117	.010	.400	.074	2	.1250	1.5	MEF-078-400-010	36.85	MEF-078-400-010K	41.10
.0781	.0781	.117	.010	.400	.074	3	.1250	1.5	MEF-078-400-3-010	36.85	MEF-078-400-3-010K	41.10
.0781	.0781	.117	.010	.650	.074	2	.1250	2.0	MEF-078-650-010	41.40	MEF-078-650-010K	45.65
.0781	.0781	.117	.010	.650	.074	3	.1250	2.0	MEF-078-650-3-010	41.40		
.0781	.0781	.117	.010	.900	.074	2	.1250	2.0	MEF-078-900-010	49.60	MEF-078-900-010K	53.85
.0781	.0781	.117	.010	.900	.074	3	.1250	2.0	MEF-078-900-3-010	49.60	MEF-078-900-3-010K	53.85
.0781	.0781	.117	.015	.250	.074	2	.1250	1.5	MEF-078-250-015	34.60	MEF-078-250-015K	38.85
.0781	.0781	.117	.015	.250	.074	3	.1250	1.5	MEF-078-250-3-015	34.60	MEF-078-250-3-015K	38.85
.0781	.0781	.117	.015	.400	.074	2	.1250	1.5	MEF-078-400-015	36.85	MEF-078-400-015K	41.10
.0781	.0781	.117	.015	.400	.074	3	.1250	1.5	MEF-078-400-3-015	36.85	MEF-078-400-3-015K	41.10
.0781	.0781	.117	.015	.650	.074	2	.1250	2.0	MEF-078-650-015	41.40	MEF-078-650-015K	45.65
.0781	.0781	.117	.015	.650	.074	3	.1250	2.0			MEF-078-650-3-015K	45.65
.0781	.0781	.117	.015	.900	.074	2	.1250	2.0			MEF-078-900-015K	53.85
.0781	.0781	.117	.015	.900	.074	3	.1250	2.0	MEF-078-900-3-015	49.60	MEF-078-900-3-015K	53.85
2 mm	.0787	2.5 mm	0.15 mm	7 mm	1.9 mm	2	3 mm	38 mm	MEFM-020-700-15	39.70	MEFM-020-700-15K	43.95
2 mm	.0787	2.5 mm	0.15 mm	12 mm	1.9 mm	2	3 mm	38 mm	MEFM-020-1200-15	46.80	MEFM-020-1200-15K	51.05
2 mm	.0787	2.5 mm	0.15 mm	16 mm	1.9 mm	2	3 mm	38 mm			MEFM-020-1600-15K	53.60
2 mm	.0787	2.5 mm	0.15 mm	25 mm	1.9 mm	2	3 mm	50 mm			MEFM-020-2500-15K	71.20
2 mm	.0787	2.5 mm	0.25 mm	7 mm	1.9 mm	2	3 mm	38 mm	MEFM-020-700-25	39.70	MEFM-020-700-25K	43.95
2 mm	.0787	2.5 mm	0.25 mm	12 mm	1.9 mm	2	3 mm	38 mm	MEFM-020-1200-25	46.80	MEFM-020-1200-25K	51.05
2 mm	.0787	2.5 mm	0.25 mm	16 mm	1.9 mm	2	3 mm	38 mm	MEFM-020-1600-25	49.35	MEFM-020-1600-25K	53.60
2 mm	.0787	2.5 mm	0.25 mm	20 mm	1.9 mm	2	3 mm	50 mm	MEFM-020-2000-25	60.70	MEFM-020-2000-25K	64.90
2 mm	.0787	2.5 mm	0.25 mm	25 mm	1.9 mm	2	3 mm	50 mm	MEFM-020-2500-25	66.95	MEFM-020-2500-25K	71.20
.0900	.0900	.125	.005	.250	.086	2	.1250	1.5	MEF-090-250-005	34.60	MEF-090-250-005K	38.85
.0900	.0900	.125	.005	.400	.086	2	.1250	1.5	MEF-090-400-005	36.85	MEF-090-400-005K	41.10
.0900	.0900	.125	.005	.650	.086	2	.1250	2.0	MEF-090-650-005	41.40	MEF-090-650-005K	45.65
.0900	.0900	.125	.005	.900	.086	2	.1250	2.0	MEF-090-900-005	49.60	MEF-090-900-005K	53.85
.0900	.0900	.125	.010	.250	.086	2	.1250	1.5	MEF-090-250-010	34.60	MEF-090-250-010K	38.85
.0900	.0900	.125	.010	.400	.086	2	.1250	1.5	MEF-090-400-010	36.85	MEF-090-400-010K	41.10
.0900	.0900	.125	.010	.650	.086	2	.1250	2.0	MEF-090-650-010	41.40	MEF-090-650-010K	45.65
.0900	.0900	.125	.010	.900	.086	2	.1250	2.0	MEF-090-900-010	49.60	MEF-090-900-010K	53.85
.0900	.0900	.125	.015	.250	.086	2	.1250	1.5	MEF-090-250-015	34.60	MEF-090-250-015K	38.85
.0900	.0900	.125	.015	.400	.086	2	.1250	1.5	MEF-090-400-015	36.85	MEF-090-400-015K	41.10
.0900	.0900	.125	.015	.650	.086	2	.1250	2.0	MEF-090-650-015	41.40	MEF-090-650-015K	45.65
.0900	.0900	.125	.015	.900	.086	2	.1250	2.0	MEF-090-900-015	49.60	MEF-090-900-015K	53.85
.0938	.0938	.125	.005	.250	.089	2	.1250	1.5	MEF-093-250-005	34.60	MEF-093-250-005K	38.85
.0938	.0938	.125	.005	.500	.089	2	.1250	1.5			MEF-093-500-005K	45.65
.0938	.0938	.125	.005	.750	.089	2	.1250	2.0	MEF-093-750-005	47.05	MEF-093-750-005K	51.30
.0938	.0938	.125	.005	1.000	.089	2	.1250	2.0	MEF-093-1000-005	49.60	MEF-093-1000-005K	53.85
.0938	.0938	.125	.010	.250	.089	2	.1250	1.5	MEF-093-250-010	34.60	MEF-093-250-010K	38.85
.0938	.0938	.125	.010	.500	.089	2	.1250	1.5	MEF-093-500-010	41.40	MEF-093-500-010K	45.65
.0938	.0938	.125	.010	.750	.089	2	.1250	2.0	MEF-093-750-010	47.05	MEF-093-750-010K	51.30

*.0005" / .013 mm max TIR

Continued on next page

Steels & High Temp. Alloys

End Mills For Steels & High Temp Alloys

Corner Radius – 2 & 3 Flute – Long Reach, Stub Flute (cont.)

MEF / MEFM

Continued from previous page

Steels & High Temp. Alloys

Cutter Diameter*	Length of Cut	Corner Radius	Overall Reach	Neck Dia.	Flutes	Shank Dia.	Overall Length	Uncoated		nACRo® Coated	
								Tool #	Price	Tool #	Price
D1 +.0000" +.000mm -.0005" -.013mm	L2	R +.0000mm -.013mm	L3 +.25mm -.00mm	D3		D2 (h6)	L1				
.0938 .0938	.125	.010	1.000	.089	2	.1250	2.0	MEF-093-1000-010	49.60	MEF-093-1000-010K	53.85
.0938 .0938	.125	.015	.250	.089	2	.1250	1.5	MEF-093-250-015	34.60	MEF-093-250-015K	38.85
.0938 .0938	.125	.015	.500	.089	2	.1250	1.5	MEF-093-500-015	41.40	MEF-093-500-015K	45.65
.0938 .0938	.125	.015	1.000	.089	2	.1250	2.0	MEF-093-1000-015	49.60		
2.5 mm .0984	3 mm	0.15 mm	15 mm	2.4 mm	2	3 mm	38 mm	MEFM-025-1500-15	49.35	MEFM-025-1500-15K	53.60
2.5 mm .0984	3 mm	0.15 mm	20 mm	2.4 mm	2	3 mm	50 mm	MEFM-025-2000-15	60.70	MEFM-025-2000-15K	64.90
2.5 mm .0984	3 mm	0.15 mm	25 mm	2.4 mm	2	3 mm	50 mm	MEFM-025-2500-15	66.95	MEFM-025-2500-15K	71.20
2.5 mm .0984	3 mm	0.15 mm	30 mm	2.4 mm	2	3 mm	60 mm			MEFM-025-3000-15K	77.80
2.5 mm .0984	3 mm	0.25 mm	20 mm	2.4 mm	2	3 mm	50 mm	MEFM-025-2000-25	60.70	MEFM-025-2000-25K	64.90
2.5 mm .0984	3 mm	0.25 mm	25 mm	2.4 mm	2	3 mm	50 mm	MEFM-025-2500-25	66.95	MEFM-025-2500-25K	71.20
3 mm .1181	3 mm	0.15 mm	10 mm	2.9 mm	2	6 mm	57 mm			MEFM-030-1000-15K	55.00
3 mm .1181	3 mm	0.15 mm	15 mm	2.9 mm	2	6 mm	57 mm	MEFM-030-1500-15	56.00	MEFM-030-1500-15K	62.10
3 mm .1181	3 mm	0.15 mm	25 mm	2.9 mm	2	6 mm	57 mm			MEFM-030-2500-15K	72.25
3 mm .1181	3 mm	0.15 mm	30 mm	2.9 mm	2	6 mm	57 mm	MEFM-030-3000-15	70.35	MEFM-030-3000-15K	76.45
3 mm .1181	3 mm	0.25 mm	10 mm	2.9 mm	2	6 mm	57 mm	MEFM-030-1000-25	48.90	MEFM-030-1000-25K	55.00
3 mm .1181	3 mm	0.25 mm	15 mm	2.9 mm	2	6 mm	57 mm	MEFM-030-1500-25	56.00	MEFM-030-1500-25K	62.10
3 mm .1181	3 mm	0.25 mm	30 mm	2.9 mm	2	6 mm	57 mm	MEFM-030-3000-25	70.35		
.1250 .1250	.125	.005	.375	.121	2	.1875	2.0	MEF-125-375-005	36.85	MEF-125-375-005K	41.60
.1250 .1250	.125	.005	.750	.121	2	.1875	2.0	MEF-125-750-005	43.65	MEF-125-750-005K	48.45
.1250 .1250	.125	.005	1.000	.121	2	.1875	2.0	MEF-125-1000-005	49.35	MEF-125-1000-005K	54.10
.1250 .1250	.125	.005	1.500	.121	2	.1875	3.0	MEF-125-1500-005	53.25		
.1250 .1250	.125	.010	.375	.121	2	.1875	2.0	MEF-125-375-010	36.85		
.1250 .1250	.125	.010	.750	.121	2	.1875	2.0	MEF-125-750-010	43.65	MEF-125-750-010K	48.45
.1250 .1250	.125	.010	1.000	.121	2	.1875	2.0	MEF-125-1000-010	49.35		
.1250 .1250	.125	.010	1.500	.121	2	.1875	3.0	MEF-125-1500-010	53.25	MEF-125-1500-010K	58.35
.1250 .1250	.125	.015	.375	.121	2	.1875	2.0	MEF-125-375-015	36.85	MEF-125-375-015K	41.60
.1250 .1250	.125	.015	.750	.121	2	.1875	2.0	MEF-125-750-015	43.65	MEF-125-750-015K	48.45
.1250 .1250	.125	.015	1.000	.121	2	.1875	2.0	MEF-125-1000-015	49.35	MEF-125-1000-015K	54.10
4 mm .1575	5 mm	0.25 mm	30 mm	3.9 mm	2	6 mm	57 mm			MEFM-040-3000-25K	76.25
4 mm .1575	5 mm	0.5 mm	30 mm	3.9 mm	2	6 mm	57 mm	MEFM-040-3000-50	70.15	MEFM-040-3000-50K	76.25
4 mm .1575	5 mm	1 mm	30 mm	3.9 mm	2	6 mm	57 mm	MEFM-040-3000-100	70.15	MEFM-040-3000-100K	76.25
.1875 .1875	.200	.005	1.000	.183	2	.2500	2.5	MEF-187-1000-005	62.40	MEF-187-1000-005K	68.50
.1875 .1875	.200	.010	1.000	.183	2	.2500	2.5	MEF-187-1000-010	62.40	MEF-187-1000-010K	68.50
.1875 .1875	.200	.010	1.500	.183	2	.2500	3.0	MEF-187-1500-010	70.35	MEF-187-1500-010K	76.45
.1875 .1875	.200	.015	1.000	.183	2	.2500	2.5	MEF-187-1000-015	62.40	MEF-187-1000-015K	68.50
.1875 .1875	.200	.015	1.500	.183	2	.2500	3.0	MEF-187-1500-015	70.35	MEF-187-1500-015K	76.45
.1875 .1875	.200	.005	.750	.183	2	.2500	2.5	MEF-187-750-005	55.55	MEF-187-750-005K	61.65
.1875 .1875	.200	.015	.750	.183	2	.2500	2.5	MEF-187-750-015	55.55	MEF-187-750-015K	61.65
.1875 .1875	.200	.010	.750	.183	2	.2500	2.5	MEF-187-750-010	55.55	MEF-187-750-010K	61.65

*.0005" / .013 mm max TIR

Continued on next page

MEF / MEFM

End Mills For Steels & High Temp Alloys

Corner Radius – 2 & 3 Flute – Long Reach, Stub Flute (cont.)

Continued from previous page

Cutter Diameter*	Length of Cut	Corner Radius	Overall Reach	Neck Dia.	Flutes	Shank Dia.	Overall Length	Uncoated		nACRo® Coated	
								Tool #	Price	Tool #	Price
D1 +.0000"/+.000mm -.0005"/-.013mm	L2 +.015" -.000"	R +.0000" -.0005"	L3 +.010" -.010"	D3			L1	Tool #	Price	Tool #	Price
5 mm .1969	6 mm	0.25 mm	15 mm	4.9 mm	2	6 mm	57 mm	MEFM-050-1500-25	55.95	MEFM-050-1500-25K	62.05
5 mm .1969	6 mm	0.25 mm	25 mm	4.9 mm	2	6 mm	57 mm	MEFM-050-2500-25	63.90	MEFM-050-2500-25K	70.00
5 mm .1969	6 mm	0.25 mm	30 mm	4.9 mm	2	6 mm	57 mm			MEFM-050-3000-25K	76.25
5 mm .1969	6 mm	0.5 mm	30 mm	4.9 mm	2	6 mm	57 mm	MEFM-050-3000-50	70.15	MEFM-050-3000-50K	76.25
5 mm .1969	6 mm	1 mm	30 mm	4.9 mm	2	6 mm	57 mm	MEFM-050-3000-100	70.15		
D1 +.0000" -.0010"	L2 +.015" -.000"	R +.0000" -.0005"	L3 +.010" -.010"	D3		D2 (h6)	L1	Tool #	Price	Tool #	Price
.2500 .2500	.250	.005	.750	.246	2	.2500	2.5	MEF-250-750-005	55.55	MEF-250-750-005K	61.65
.2500 .2500	.250	.010	.750	.246	2	.2500	2.5	MEF-250-750-010	55.55	MEF-250-750-010K	61.65
.2500 .2500	.250	.015	.750	.246	2	.2500	2.5	MEF-250-750-015	55.55	MEF-250-750-015K	61.65
.2500 .2500	.250	.010	1.000	.246	2	.2500	2.5	MEF-250-1000-010	62.40	MEF-250-1000-010K	68.50
.2500 .2500	.250	.005	1.000	.246	2	.2500	2.5	MEF-250-1000-005	62.40	MEF-250-1000-005K	68.50
.2500 .2500	.250	.015	1.000	.246	2	.2500	2.5	MEF-250-1000-015	62.40	MEF-250-1000-015K	68.50

*.0005" / .013 mm max TIR

Steels & High Temp. Alloys

End Mills For Steels & High Temp Alloys

Corner Radius – 4 Flute – Variable Helix

VHS / VHSM
VHM / VHMM

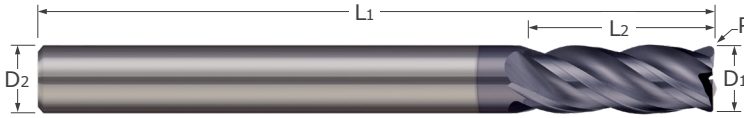

Steels & High Temp. Alloys

- Designed for high performance in titanium alloys, inconel, nickel alloys, and other high-temperature materials with outstanding performance in difficult-to-machine steels, stainless steels, and tool steels
- Variable helix design reduces chatter and harmonics and increases material removal rates
- Specialized geometry for maximum performance in high velocity tool paths
- Corner radius profile
- Weldon flat offered on sizes 3/8" and larger
- Center cutting
- AlTiN coating option for added lubricity and increased wear resistance in difficult-to-machine materials
- Solid carbide
- CNC ground in the USA

Cutter Diameter*			Length of Cut	Corner Radius	Flutes	Shank Diameter	Overall Length	Uncoated		AlTiN Coated	
D1 +.0000" -.0020" (h9) decimal equiv.			L2 +.79 mm -.00 mm	R +.000 mm -.013 mm		D2 (h6)	L1	Tool #	Price	Tool #	Price
3 mm	.1181		8 mm	0.5 mm	4	4 mm	50 mm			VHMM-030-4X	20.95
.1250	.1250		.500	.010	4	.1250	1.5			VHM-125-4X	17.80
4 mm	.1575		8 mm	0.5 mm	4	4 mm	50 mm	VHSM-040-4	22.95	VHSM-040-4X	26.00
4 mm	.1575		11 mm	0.5 mm	4	4 mm	50 mm	VHMM-040-4	25.50		
5 mm	.1969		16 mm	0.5 mm	4	6 mm	57 mm	VHMM-050-4	30.25		
6 mm	.2362		16 mm	0.5 mm	4	6 mm	57 mm			VHMM-060-4X	35.85
.2500	.2500		.500	.020	4	.2500	2.5	VHS-250-4	27.00	VHS-250-4X	32.20
8 mm	.3150		16 mm	0.5 mm	4	8 mm	63 mm	VHSM-080-4	31.75		
8 mm	.3150		19 mm	0.5 mm	4	8 mm	63 mm	VHMM-080-4	35.35	VHMM-080-4X	42.65
.3750	.3750		.875	.020	4	.3750	2.5	VHM-375-4	39.75		
10 mm	.3937		19 mm	0.5 mm	4	10 mm	72 mm	VHSM-100-4	40.65		
10 mm	.3937		22 mm	0.6 mm	4	10 mm	72 mm	VHMM-100-4	45.15	VHMM-100-4X	52.35
.4375	.4375		1.000	.020	4	.4375	2.5	VHM-437-4	62.05	VHM-437-4X	70.65
12 mm	.4724		22 mm	0.5 mm	4	12 mm	83 mm			VHSM-120-4X	69.00
12 mm	.4724		26 mm	0.6 mm	4	12 mm	83 mm	VHMM-120-4	64.35	VHMM-120-4X	75.30
.5000	.5000		1.250	.030	4	.5000	3.5	VHM-5125-4	72.20	VHM-5125-4X	79.55
25 mm	.9843		38 mm	0.8 mm	4	25 mm	127 mm			VHMM-250-4X	324.10

*.0005" / .013 mm max TIR

VLM

End Mills For Steels & High Temp Alloys

Corner Radius – 4 & 5 Flute – Variable Helix – Long Flute

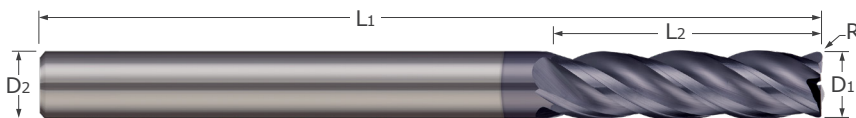

- Designed for high performance in titanium alloys, inconel, nickel alloys, and other high-temperature materials with outstanding performance in difficult-to-machine steels, stainless steels, and tool steels
- Variable helix design reduces chatter and harmonics and increases material removal rates
- Specialized geometry for maximum performance in high velocity tool paths
- Long flutes for deep pocket milling
- Corner radius profile
- Weldon flat offered on sizes 3/8" and larger
- Center cutting
- AlTiN coating option for added lubricity and increased wear resistance in difficult-to-machine materials
- nACRo® coating option for added heat resistance in difficult to machine materials
- Solid carbide
- CNC ground in the USA

Cutter Diameter	Length of Cut	Corner Radius	Flutes	Shank Dia.	Overall Length	Uncoated		AlTiN Coated		nACRo® Coated	
						Tool #	Price	Tool #	Price	Tool #	Price
D1 $\begin{smallmatrix} +.0000" \\ -.0020" \end{smallmatrix}$	L2 $\begin{smallmatrix} +.030" \\ -.000" \end{smallmatrix}$	R $\begin{smallmatrix} +.0000" \\ -.0005" \end{smallmatrix}$		D2 (h6)	L1						
.1875	.750	.0100	4	.1875	2.5			VLM-187-4X	34.70		
.2500	1.125	.0200	4	.2500	3.0	VLM-250-4	38.20				
.2500	1.125	.0200	5	.2500	3.0	VLM-250-5-020	42.80				
D1 $\begin{smallmatrix} +.0000" \\ -.0020" \end{smallmatrix}$	L2 $\begin{smallmatrix} +.030" \\ -.000" \end{smallmatrix}$	R $\begin{smallmatrix} +.0000" \\ -.0005" \end{smallmatrix}$		D2 (h6)	L1	Tool #	Price	Tool #	Price	Tool #	Price
.3125	1.125	.0200	4	.3125	3.0	VLM-312-4	42.65				
.3125	1.125	.0200	5	.3125	3.0					VLM-312-5-020K	54.90
.3750	1.250	.0200	5	.3750	3.0	VLM-375-5-020	57.30			VLM-375-5-020K	66.00
.5000	1.750	.0600	5	.5000	4.5	VLM-500-5-060	97.00				
.5000	1.750	.0900	5	.5000	4.5	VLM-500-5-090	97.00			VLM-500-5-090K	110.60

Steels & High Temp. Alloys

End Mills For Steels & High Temp Alloys

VLR / VLRM

Corner Radius – 4 Flute – Variable Helix – Long Reach – Reduced Neck

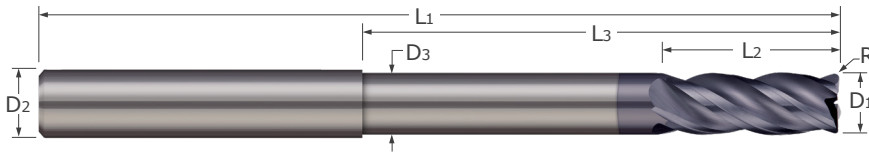

Steels & High Temp. Alloys

- Designed for high performance in titanium alloys, inconel, nickel alloys, and other high-temperature materials with outstanding performance in difficult-to-machine steels, stainless steels, and tool steels
- Variable helix design reduces chatter and harmonics and increases material removal rates
- Specialized geometry for maximum performance in high velocity tool paths
- Long reach for deep pocket milling
- Corner radius profile
- Weldon flat offered on sizes 3/8" and larger
- Center cutting
- AlTiN coating option for added lubricity and increased wear resistance in difficult-to-machine materials
- Solid carbide
- CNC ground in the USA

Cutter Diameter*	Length of Cut	Corner Radius	Overall Reach	Neck Diameter	Flutes	Shank Dia.	Overall Length	Uncoated		AlTiN Coated	
D1 +.0000" (h9) -.0020" (h9) decimal equiv.	L2 +.010" - .000" +.25 mm - .00 mm	R +.0000" - .0005" +.000mm - .013mm	L3 +.015" - .000" +.38 mm - .00 mm	D3	4	D2 (h6)	L1	Tool #	Price	Tool #	Price
6 mm .2362	8 mm	0.5 mm	30 mm	5.49 mm	4	6 mm	75 mm	VLRM-060-4	51.55	VLRM-060-4X	56.55
.2500 .2500	.500	.020	2.500	.230	4	.2500	4.0			VLR-250-4X	56.40
.3125 .3125	.625	.020	2.625	.293	4	.3125	4.0	VLR-312-4	54.65	VLR-312-4X	62.50
8 mm .3150	10 mm	0.5 mm	50 mm	7.49 mm	4	8 mm	100 mm			VLRM-080-4X	64.25
.3750 .3750	.750	.020	2.750	.355	4	.3750	4.0			VLR-375-4X	84.10
10 mm .3937	12 mm	0.6 mm	50 mm	9.5 mm	4	10 mm	100 mm	VLRM-100-4	82.00		
.5000 .5000	1.000	.030	4.500	.480	4	.5000	6.0			VLR-500-4X	149.95
.6250 .6250	1.250	.030	4.500	.605	4	.6250	6.0	VLR-625-4	211.25	VLR-625-4X	228.30
16 mm .6299	22 mm	0.7 mm	80 mm	15.49 mm	4	16 mm	130 mm	VLRM-160-4	245.60		
.7500 .7500	1.500	.030	4.500	.730	4	.7500	6.0	VLR-750-4	277.40		

*.0005" / .013 mm max TIR

ARC

End Mills For Steels & High Temp Alloys

Corner Radius – 5 Flute

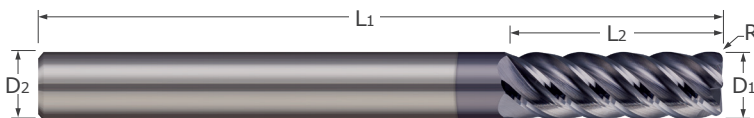

- Designed for roughing in titanium alloys, inconel, nickel alloys, and other high-temperature materials with outstanding performance in difficult-to-machine steels, stainless steels, and tool steels
- 45° high helix for reduced cutting forces and increased material removal rates
- Corner radius profile
- Weldon flat offered on sizes 3/8" and larger
- Center cutting
- AlTiN coating option for added lubricity and increased wear resistance in difficult-to-machine materials
- Solid carbide
- CNC ground in the USA

Cutter Diameter	Length of Cut	Corner Radius	Flutes	Shank Dia.	Overall Length	Uncoated		AlTiN Coated	
						Tool #	Price	Tool #	Price
D1 $\begin{matrix} +.0000" \\ -.0020" \end{matrix}$	L2 $\begin{matrix} +.030" \\ -.000" \end{matrix}$	R $\begin{matrix} +.0000" \\ -.0005" \end{matrix}$		D2 (h6)	L1				
.1875	.625	.0100	5	.1875	2.0	ARC-187-5-010	30.15	ARC-187-5-010X	33.15
.1875	.625	.0300	5	.1875	2.0	ARC-187-5-030	30.15		

Cutter Diameter	Length of Cut	Corner Radius	Flutes	Shank Dia.	Overall Length	Uncoated		AlTiN Coated	
						Tool #	Price	Tool #	Price
D1 $\begin{matrix} +.0000" \\ -.0030" \end{matrix}$	L2 $\begin{matrix} +.030" \\ -.000" \end{matrix}$	R $\begin{matrix} +.0000" \\ -.0005" \end{matrix}$		D2 (h6)	L1				
.3125	.813	.0200	5	.3125	2.5			ARC-312-5-020X	49.30
.3750	.875	.0600	5	.3750	2.5	ARC-375-5-060	47.65	ARC-375-5-060X	54.85
.5000	1.000	.0100	5	.5000	3.0	ARC-500-5-010	82.45		
.5000	1.000	.0600	5	.5000	3.0			ARC-500-5-060X	90.90
.6250	1.250	.0900	5	.6250	3.5	ARC-625-5-090	139.05	ARC-625-5-090X	151.70
.7500	1.500	.0200	5	.7500	4.0			ARC-750-5-020X	226.15
.7500	1.500	.0900	5	.7500	4.0	ARC-750-5-090	212.05		

Steels & High Temp. Alloys

End Mills For Steels & High Temp Alloys

Corner Radius – 5 Flute – Variable Helix

VHS / VHSM
VHM / VHMM

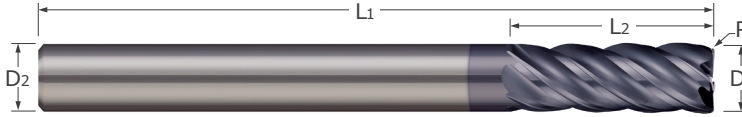

Steels & High Temp. Alloys

- Designed for high performance in titanium alloys, inconel, nickel alloys, and other high-temperature materials with outstanding performance in difficult-to-machine steels, stainless steels, and tool steels
- Variable helix design reduces chatter and harmonics and increases material removal rates
- Specialized geometry for maximum performance in high velocity tool paths
- Corner radius profile
- Weldon flat offered on sizes 3/8" and larger ■ Center cutting
- nACRo® coating option for added heat resistance in difficult to machine materials
- Solid carbide ■ CNC ground in the USA

Cutter Diameter*		Length of Cut	Corner Radius	Flutes	Shank Diameter	Overall Length	Uncoated		nACRo® Coated	
D1 +.0000" -.0020" (h9) decimal equiv.	D2	L2	R +.0000" -.0005" +.000 mm -.013 mm		D2 (h6)	L1	Tool #	Price	Tool #	Price
3 mm	.1181	6 mm	0.3 mm	5	4 mm	50 mm	VHSM-030-5	17.85	VHSM-030-5K	22.65
3 mm	.1181	8 mm	0.3 mm	5	4 mm	50 mm	VHMM-030-5	19.90	VHMM-030-5K	24.65
4 mm	.1575	8 mm	0.3 mm	5	4 mm	50 mm	VHSM-040-5	25.30	VHSM-040-5K	30.05
4 mm	.1575	11 mm	0.3 mm	5	4 mm	50 mm	VHMM-040-5	28.10	VHMM-040-5K	32.85
6 mm	.2362	10 mm	0.5 mm	5	6 mm	57 mm	VHSM-060-5	29.90	VHSM-060-5K	36.10
6 mm	.2362	16 mm	0.5 mm	5	6 mm	57 mm	VHMM-060-5	33.25	VHMM-060-5K	39.35
.2500	.2500	.500	.020	5	.2500	2.5	VHS-250-5-020	30.10		

D1 +.0000" -.0030" (h9) decimal equiv.	D2	L2	R +.0000" -.0005" +.000 mm -.013 mm	Flutes	D2 (h6)	L1	Tool #	Price	Tool #	Price
.3125	.3125	.500	.020	5	.3125	2.5	VHS-312-5-020	37.80	VHS-312-5-020K	46.60
8 mm	.3150	16 mm	0.5 mm	5	8 mm	63 mm	VHSM-080-5	35.20	VHSM-080-5K	43.90
8 mm	.3150	19 mm	0.5 mm	5	8 mm	63 mm	VHMM-080-5	39.10	VHMM-080-5K	47.80
.3750	.3750	.625	.020	5	.3750	2.5	VHS-375-5-020	41.35	VHS-375-5-020K	50.05
.3750	.3750	.875	.020	5	.3750	2.5			VHM-375-5-020K	54.65
10 mm	.3937	19 mm	0.5 mm	5	10 mm	72 mm			VHSM-100-5K	55.00
12 mm	.4724	22 mm	0.5 mm	5	12 mm	83 mm	VHSM-120-5	62.30	VHSM-120-5K	74.95
12 mm	.4724	26 mm	0.5 mm	5	12 mm	83 mm	VHMM-120-5	69.15	VHMM-120-5K	81.85
.5000	.5000	.625	.030	5	.5000	3.0	VHS-500-5-030	67.35	VHS-500-5-030K	79.20
.5000	.5000	1.000	.060	5	.5000	3.0	VHM-500-5-060	74.85		
.5000	.5000	.625	.090	5	.5000	3.0	VHS-500-5-090	67.35	VHS-500-5-090K	79.20
.5000	.5000	1.000	.090	5	.5000	3.0	VHM-500-5-090	74.85	VHM-500-5-090K	86.65
.5000	.5000	1.000	.125	5	.5000	3.0	VHM-500-5-125	74.85		
.6250	.6250	1.250	.060	5	.6250	3.5	VHM-625-5-060	140.95		
.7500	.7500	1.500	.125	5	.7500	4.0	VHM-750-5-125	207.55		

*.0005" / .013 mm max TIR

VLR

End Mills For Steels & High Temp Alloys

Corner Radius – 5 Flute – Variable Helix – Long Reach – Reduced Neck

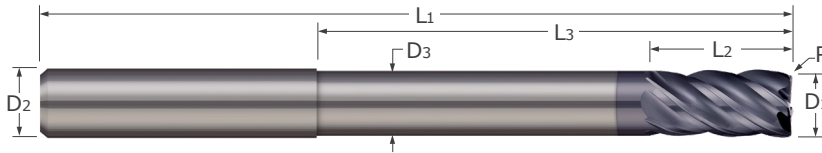

- Designed for high performance in titanium alloys, inconel, nickel alloys, and other high-temperature materials with outstanding performance in difficult-to-machine steels, stainless steels, and tool steels
- Variable helix design reduces chatter and harmonics and increases material removal rates
- Specialized geometry for maximum performance in high velocity tool paths
- Long reach for deep pocket milling
- Corner radius profile
- Weldon flat offered on sizes 3/8" and larger ■ Center cutting
- nACRo® coating option for added heat resistance in difficult to machine materials
- Solid carbide ■ CNC ground in the USA

Cutter Diameter	Length of Cut	Corner Radius	Overall Reach	Neck Diameter	Flutes	Shank Dia.	Overall Length	Uncoated		nACRo® Coated	
								Tool #	Price	Tool #	Price
D1 $^{+.0000''}$ $_{-.0030''}$	L2 $^{+.010''}$ $_{-.000''}$	R $^{+.0000''}$ $_{-.0005''}$	L3 $^{+.015''}$ $_{-.000''}$	D3		D2 (h6)	L1				
.3125	.625	.0200	2.625	.292	5	.3125	4.0	VLR-312-5-020	57.80		
.3750	.750	.0200	2.750	.355	5	.3750	4.0	VLR-375-5-020	80.00	VLR-375-5-020K	89.30
.5000	1.000	.0300	4.500	.480	5	.5000	6.0	VLR-500-5-030	141.80	VLR-500-5-030K	156.50
.5000	1.000	.0600	4.500	.480	5	.5000	6.0	VLR-500-5-060	141.80		
.5000	1.000	.0900	4.500	.480	5	.5000	6.0	VLR-500-5-090	141.80	VLR-500-5-090K	156.50
.5000	1.000	.1250	4.500	.480	5	.5000	6.0			VLR-500-5-125K	156.50

End Mills For Aluminum Alloys

Square – 2 & 3 Flute – Stub & Standard

ASM / ASMM
ARM / ARMM



- Designed for exceptional performance in aluminum, non ferrous materials and soft materials
- 45° high helix for reduced cutting forces and increased material removal rates
- Square profile
- Center cutting
- ZrN coated option for high hardness, lubricity, and abrasion resistance
- Solid carbide ■ CNC ground in the USA

Aluminum Alloys

Cutter Diameter*		Length of Cut	Flutes	Shank Diameter	Overall Length	Uncoated		ZrN Coated	
D1 (h8)	decimal equiv.					L2	D2 (h6)	L1	Tool #
1 mm	.0394	3 mm	2	4 mm	50 mm	ARMM-010-2	22.55		
2 mm	.0787	4 mm	2	4 mm	50 mm	ASMM-020-2	22.55		
5 mm	.1969	20 mm	2	6 mm	57 mm	ARMM-050-2	28.45		
6 mm	.2362	20 mm	3	6 mm	57 mm	ARMM-060-3	28.45		

D1			L2	D2 (h6)	L1	Tool #	Price	Tool #	Price	
+ .0000"	+ .00 mm	decimal equiv.								
.2813	.2813	.2813	.750	2	.3125	2.5	ARM-281-2	35.15	ARM-281-2S	42.45
.2813	.2813	.2813	.750	3	.3125	2.5			ARM-281-3S	42.45
.3125	.3125	.3125	.500	2	.3125	2.0	ASM-312-2	31.55		
.3125	.3125	.3125	.813	3	.3125	2.5	ARM-312-3	35.15		
8 mm	.3150	.3150	25 mm	2	8 mm	63 mm			ARMM-080-2S	43.85
8 mm	.3150	.3150	25 mm	3	8 mm	63 mm	ARMM-080-3	35.15	ARMM-080-3S	43.85
10 mm	.3937	.3937	19 mm	2	10 mm	72 mm	ASMM-100-2	39.35		
12 mm	.4724	.4724	30 mm	3	12 mm	83 mm	ARMM-120-3	65.90	ARMM-120-3S	78.55
.5000	.5000	.5000	.625	2	.5000	2.5	ASM-500-2	62.20	ASM-500-2S	72.65
.5000	.5000	.5000	1.250	2	.5000	3.5	ARM-5125-2	72.45		
.5000	.5000	.5000	1.250	3	.5000	3.5	ARM-5125-3	72.45		
14 mm	.5510	.5510	30 mm	3	14 mm	83mm	ARMM-140-3	76.55		
.6250	.6250	.6250	1.250	3	.6250	3.5	ARM-625-3	122.05		
16 mm	.6299	.6299	35 mm	2	16 mm	92 mm	ARMM-160-2	122.90	ARMM-160-2S	137.80
16 mm	.6299	.6299	35 mm	3	16 mm	92 mm			ARMM-160-3S	137.80
18 mm	.7087	.7087	45 mm	3	18 mm	92 mm	ARMM-180-3	163.95		
20 mm	.7874	.7874	45 mm	3	20 mm	104 mm			ARMM-200-3S	231.15

*.0005" / .013 mm max TIR

SFA / SFAM

End Mills For Aluminum Alloys
Square – Single Flute – Upcut Router

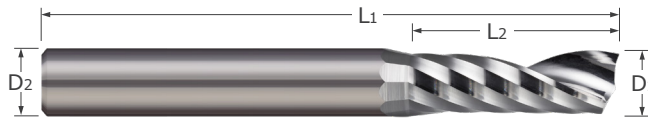

- Single flute design for applications in aluminum and non-ferrous materials
- Polished flute improves chip evacuation and helps to reduce built up edge
- Optimized geometry for increased material removal rates
- End cutting
- Solid carbide
- CNC ground in the USA

Cutter Diameter*			Length of Cut	Shank Diameter	Overall Length	Uncoated	
D1 +.0000" -.0020"	+.00 mm -.05 mm	decimal equiv.	L2 +.015" -.000" +.38 mm -.00 mm	D2 (h6)	L1	Tool #	Price
						.0625	.0625
.0625	.0625	.250	.2500	2.0	SFA-062-42	35.30	
2 mm	.0787	6 mm	6 mm	57 mm	SFAM-020020	33.15	
3 mm	.1181	12 mm	6 mm	57 mm	SFAM-030020	33.15	
.1250	.1250	.250	.1250	1.5	SFA-125-22	26.50	
.1250	.1250	.250	.2500	2.0	SFA-125-42	30.85	
.1250	.1250	.500	.1250	1.5	SFA-125-24	26.50	
.1250	.1250	.500	.2500	2.0	SFA-125-44	30.85	
.1562	.1562	.625	.2500	2.0	SFA-156-45	30.85	
4 mm	.1575	16 mm	6 mm	57 mm	SFAM-040020	33.15	
.1875	.1875	.500	.1875	2.0	SFA-187-33	29.25	
.1875	.1875	.500	.2500	2.0	SFA-187-44	30.85	
.1875	.1875	.625	.1875	2.0	SFA-187-35	29.25	
.1875	.1875	.625	.2500	2.0	SFA-187-45	30.85	
5 mm	.1969	20 mm	6 mm	57 mm	SFAM-050025	33.15	
.2188	.2188	.750	.2500	2.5	SFA-218-46	30.85	
6 mm	.2362	20 mm	6 mm	100 mm	SFAM-060100	49.60	
6 mm	.2362	25 mm	6 mm	57 mm	SFAM-060030	33.15	
.2500	.2500	.375	.2500	2.5	SFA-250-43	30.85	
.2500	.2500	.750	.2500	2.5	SFA-250-46	30.85	
.2500	.2500	1.250	.2500	3.0	SFA-250-410	34.75	
8 mm	.3150	20 mm	8 mm	100 mm	SFAM-080100	63.40	
8 mm	.3150	30 mm	8 mm	75 mm	SFAM-080040	50.85	
.3750	.3750	1.125	.3750	3.0	SFA-375-69	46.20	
10 mm	.3937	25 mm	10 mm	120 mm	SFAM-100100	77.20	
10 mm	.3937	35 mm	10 mm	90 mm	SFAM-100050	67.50	
12 mm	.4724	40 mm	12 mm	90 mm	SFAM-120050	83.75	
.5000	.5000	1.000	.5000	3.0	SFA-500-88	76.55	
.5000	.5000	1.500	.5000	4.0	SFA-500-812	80.50	
20 mm	.7874	40 mm	20 mm	150 mm	SFAM-200100	329.40	
20 mm	.7874	50 mm	20 mm	100 mm	SFAM-200050	252.60	

*.0005" / .013 mm max TIR

End Mills For Aluminum Alloys

Corner Radius – 2 & 3 Flute

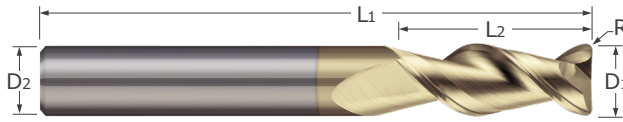

- Designed for exceptional performance in aluminum, non ferrous materials and soft materials
- 45° high helix for reduced cutting forces and increased material removal rates
- Stub flutes for maximum rigidity
- Corner radius profile
- Center cutting
- ZrN coated option for high hardness, lubricity, and abrasion resistance
- Solid carbide ■ CNC ground in the USA

Aluminum Alloys

Cutter Diameter	Length of Cut	Corner Radius	Flutes	Shank Dia.	Overall Length	Uncoated		ZrN Coated	
						Tool #	Price	Tool #	Price
D1 $^{+.0000}$ / $_{-.0020}$ "	L2 $^{+.030}$ / $_{-.000}$ "	R $^{+.0000}$ / $_{-.0005}$ "		D2 (h6)	L1				
.2500	.750	.0100	2	.2500	2.5	ARC-250-2-010	34.60		
D1 $^{+.0000}$ / $_{-.0030}$ "	L2 $^{+.030}$ / $_{-.000}$ "	R $^{+.0000}$ / $_{-.0005}$ "		D2 (h6)	L1	Tool #	Price	Tool #	Price
.3125	.813	.0300	2	.3125	2.5			ARC-312-2-030S	46.05
.3125	.813	.0300	3	.3125	2.5	ARC-312-3-030	38.75		
.5000	1.000	.0300	3	.5000	3.0	ARC-500-3-030	76.00	ARC-500-3-030S	86.30
.5000	1.250	.0300	3	.5000	3.5	ARC-5125-3-030	79.75		
.6250	1.250	.0300	2	.6250	3.5	ARC-625-2-030	134.20		
.6250	1.250	.0600	2	.6250	3.5	ARC-625-2-060	134.20		
.6250	1.250	.0600	3	.6250	3.5	ARC-625-3-060	134.20		
.6250	1.250	.0900	2	.6250	3.5	ARC-625-2-090	134.20		
.6250	1.250	.0900	3	.6250	3.5	ARC-625-3-090	134.20		
.7500	1.500	.0600	2	.7500	4.0	ARC-750-2-060	195.35		
1.0000	1.500	.0200	2	1.0000	4.0	ARC-001-2-020	295.90		
1.0000	1.500	.0300	2	1.0000	4.0	ARC-001-2-030	295.90		
1.0000	1.500	.0600	2	1.0000	4.0	ARC-001-2-060	295.90		
1.0000	1.500	.0900	2	1.0000	4.0	ARC-001-2-090	295.90	ARC-001-2-090S	321.20
1.0000	1.500	.1250	2	1.0000	4.0	ARC-001-2-125	295.90	ARC-001-2-125S	321.20

* .0005" max TIR

SFP / SFPM

End Mills For Plastics & Composites

Square – Single Flute – Upcut Router

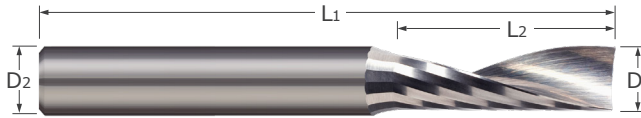

- Single flute design for applications in plastics
- Polished flute improves chip evacuation
- Optimized geometry for increased material removal rates
- End cutting ■ Solid carbide ■ CNC ground in the USA

Cutter Diameter*			Length of Cut	Shank Diameter	Overall Length	Uncoated	
D1 +.0000" -.0020"	+.00 mm -.05 mm	decimal equiv.	L2 +.015" -.000" +.38 mm -.00 mm	D2 (h6)	L1	Tool #	Price
						1 mm	.0394
.0625	.0625	.0625	.250	.1250	1.50	SFP-062-22	30.00
.0625	.0625	.0625	.250	.2500	2.00	SFP-062-42	35.30
2 mm	.0787	.0787	6 mm	3 mm	57 mm	SFPM-020-10	28.65
2 mm	.0787	.0787	10 mm	3 mm	38 mm	SFPM-020-20	25.95
2 mm	.0787	.0787	12 mm	3 mm	57 mm	SFPM-020-30	28.65
2 mm	.0787	.0787	14 mm	3 mm	75 mm	SFPM-020-40	33.15
3 mm	.1181	.1181	8 mm	3 mm	57 mm	SFPM-030-10	28.65
3 mm	.1181	.1181	8 mm	6 mm	57 mm	SFPM-030-50	31.45
3 mm	.1181	.1181	12 mm	3 mm	38 mm	SFPM-030-20	25.95
3 mm	.1181	.1181	18 mm	6 mm	57 mm	SFPM-030-60	33.85
3 mm	.1181	.1181	18 mm	6 mm	75 mm	SFPM-030-70	41.50
.1250	.1250	.1250	.250	.1250	1.50	SFP-125-22	26.50
.1250	.1250	.1250	.250	.2500	2.00	SFP-125-42	30.85
.1250	.1250	.1250	.500	.1250	1.50	SFP-125-24	26.50
.1250	.1250	.1250	.500	.2500	2.00	SFP-125-44	30.85
.1562	.1562	.1562	.625	.2500	2.00	SFP-156-45	30.85
4 mm	.1575	.1575	12 mm	4 mm	50 mm	SFPM-040-10	30.50
4 mm	.1575	.1575	12 mm	6 mm	57 mm	SFPM-040-50	31.45
4 mm	.1575	.1575	15 mm	4 mm	50 mm	SFPM-040-20	28.05
4 mm	.1575	.1575	20 mm	6 mm	57 mm	SFPM-040-60	33.85
4 mm	.1575	.1575	20 mm	6 mm	75 mm	SFPM-040-70	41.50
4 mm	.1575	.1575	20 mm	8 mm	100 mm	SFPM-040-80	47.35
.1875	.1875	.1875	.500	.1875	2.00	SFP-187-33	29.25
.1875	.1875	.1875	.500	.2500	2.00	SFP-187-44	30.85
.1875	.1875	.1875	.625	.1875	2.00	SFP-187-35	29.25
.1875	.1875	.1875	.625	.2500	2.00	SFP-187-45	30.85
5 mm	.1969	.1969	16 mm	5 mm	50 mm	SFPM-050-10	38.85
5 mm	.1969	.1969	16 mm	6 mm	57 mm	SFPM-050-40	40.65
5 mm	.1969	.1969	20 mm	8 mm	95 mm	SFPM-050-70	47.35
5 mm	.1969	.1969	28 mm	6 mm	57 mm	SFPM-050-50	40.65
5 mm	.1969	.1969	28 mm	6 mm	75 mm	SFPM-050-60	43.60

*.0005" / .013 mm max TIR

Continued on next page

End Mills For Plastics & Composites

Square – Single Flute – Upcut Router (cont.)

SFP / SFPM

Continued from previous page

Cutter Diameter*			Length of Cut	Shank Diameter	Overall Length	Uncoated	
D ₁ +.0000" -.0020"	+.00 mm -.05 mm	decimal equiv.	L ₂ +.015" -.000" +.38 mm -.00 mm	D ₂ (h6)	L ₁	Tool #	Price
						6 mm	.2362
6 mm	.2362	20 mm	6 mm	57 mm	SFPM-060-20	41.50	
6 mm	.2362	20 mm	8 mm	95 mm	SFPM-060-60	47.35	
6 mm	.2362	35 mm	6 mm	75 mm	SFPM-060-30	43.60	
6 mm	.2362	35 mm	8 mm	75 mm	SFPM-060-50	50.00	
.2500	.2500	.375	.2500	2.50	SFP-250-43	30.85	
.2500	.2500	.750	.2500	2.50	SFP-250-46	30.85	
.2500	.2500	1.250	.2500	3.00	SFP-250-410	34.75	
8 mm	.3150	18 mm	8 mm	50 mm	SFPM-080-10	36.50	
8 mm	.3150	22 mm	8 mm	63 mm	SFPM-080-20	39.45	
8 mm	.3150	30 mm	8 mm	75 mm	SFPM-080-30	47.35	
8 mm	.3150	40 mm	8 mm	100 mm	SFPM-080-40	60.40	
.3750	.3750	1.125	.3750	3.00	SFP-375-69	46.20	
10 mm	.3937	25 mm	10 mm	72 mm	SFPM-100-10	50.70	
10 mm	.3937	30 mm	10 mm	150 mm	SFPM-100-30	89.25	
10 mm	.3937	55 mm	10 mm	100 mm	SFPM-100-20	71.85	
12 mm	.4724	30 mm	12 mm	83 mm	SFPM-120-10	77.45	
12 mm	.4724	40 mm	12 mm	150 mm	SFPM-120-20	115.35	
.5000	.5000	1.000	.5000	3.00	SFP-500-88	76.55	
.5000	.5000	1.500	.5000	4.00	SFP-500-812	80.50	

*.0005" / .013 mm max TIR

Plastics & Composites

SFL / SFLM

End Mills For Plastics & Composites

Square – Single Flute – Downcut Router

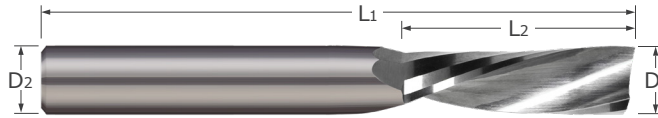

- Single flute design for applications in plastics and composites
- Left hand spiral routers drive chips downward, preventing delamination in multi-layered workpieces
- Polished flute improves chip evacuation
- Optimized geometry for increased material removal rates
- End cutting
- Solid carbide ■ CNC ground in the USA

Cutter Diameter*			Length of Cut	Shank Diameter	Overall Length	Uncoated	
D1 +.0000" -.0020"	+.00 mm -.05 mm	decimal equiv.	L2 +.015" -.000" +.38 mm -.00 mm	D2 (h6)	L1	Tool #	Price
						1 mm	.0394
.0625	.0625	.0625	.250	.2500	2.0	SFL-062-42	35.30
2 mm	.0787	6 mm	3 mm	57 mm		SFLM-020-10	28.65
2 mm	.0787	14 mm	3 mm	75 mm		SFLM-020-40	33.15
3 mm	.1181	8 mm	3 mm	57 mm		SFLM-030-10	28.65
3 mm	.1181	12 mm	3 mm	38 mm		SFLM-030-20	25.95
.1250	.1250	.250	.1250	1.5		SFL-125-22	26.50
.1250	.1250	.250	.2500	2.0		SFL-125-42	30.85
.1250	.1250	.500	.1250	1.5		SFL-125-24	26.50
.1250	.1250	.500	.2500	2.0		SFL-125-44	30.85
4 mm	.1575	12 mm	4 mm	57 mm		SFLM-040-10	30.50
4 mm	.1575	15 mm	4 mm	40 mm		SFLM-040-20	28.05
4 mm	.1575	20 mm	6 mm	57 mm		SFLM-040-60	33.85
4 mm	.1575	20 mm	6 mm	75 mm		SFLM-040-70	41.50
4 mm	.1575	20 mm	8 mm	95 mm		SFLM-040-80	47.35
.1875	.1875	.500	.1875	2.0		SFL-187-33	29.25
.1875	.1875	.500	.2500	2.0		SFL-187-44	30.85
.1875	.1875	.625	.1875	2.0		SFL-187-35	29.25
.1875	.1875	.625	.2500	2.0		SFL-187-45	30.85
5 mm	.1969	16 mm	6 mm	57 mm		SFLM-050-40	40.65
5 mm	.1969	20 mm	8 mm	95 mm		SFLM-050-70	47.35
5 mm	.1969	28 mm	6 mm	57 mm		SFLM-050-50	40.65
5 mm	.1969	28 mm	6 mm	75 mm		SFLM-050-60	43.60
.2188	.2188	.750	.2500	2.5		SFL-218-46	30.85
6 mm	.2362	16 mm	6 mm	57 mm		SFLM-060-10	40.65
6 mm	.2362	20 mm	8 mm	95 mm		SFLM-060-60	47.35
6 mm	.2362	20 mm	6 mm	57 mm		SFLM-060-20	41.50
.2500	.2500	.375	.2500	2.5		SFL-250-43	30.85
.2500	.2500	.750	.2500	2.5		SFL-250-46	30.85
.2500	.2500	1.250	.2500	3.0		SFL-250-410	34.75
.3750	.3750	1.125	.3750	3.0		SFL-375-69	46.20
12 mm	.4724	30 mm	12 mm	83 mm		SFLM-120-10	77.45
.5000	.5000	1.500	.5000	4.0		SFL-500-812	80.50

*.0005" / .013 mm max TIR

End Mills For Plastics & Composites

RDA

Diamond Cut – No End Cut

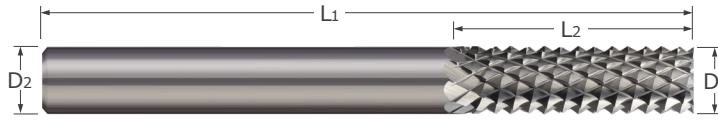

- Ideal for routing fiber reinforced, epoxy resin, and composites
- Diamond-cut flute pattern provides smooth cutting action and reduces delamination
- Non end-cutting
- Solid carbide
- CNC ground in the USA

Plastics & Composites

Cutter Diameter*	Length of Cut	Shank Dia.	Overall Length	Uncoated	
				Tool #	Price
D1 $+0.0000''$ $-0.0030''$	L2 $+0.030''$ $-0.000''$	D2 (h6)	L1		
.0625	.188	.1250	1.5	RDA-10	12.85
.0938	.375	.1250	1.5	RDA-20	12.85
.1250	.500	.1250	1.5	RDA-30	12.85
.1875	.625	.1875	2.0	RDA-40	18.15
.2500	.750	.2500	2.0	RDA-60	22.00
.2500	.750	.2500	2.5	RDA-70	23.50
.2500	1.000	.2500	3.0	RDA-80	30.70

*.0005" max TIR

End Mills For Plastics & Composites

RDB

Diamond Cut – Burr End Cut

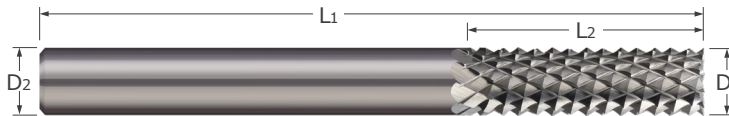

- Ideal for routing fiber reinforced, epoxy resin, and composites
- Diamond-cut flute pattern provides smooth cutting action and reduces delamination
- Burr end cut profile
- Solid carbide
- CNC ground in the USA

Cutter Diameter*	Length of Cut	Shank Dia.	Overall Length	Uncoated	
				Tool #	Price
D1 $+0.0000''$ $-0.0030''$	L2 $+0.030''$ $-0.000''$	D2 (h6)	L1		
.0625	.188	.1250	1.5	RDB-10	15.25
.0938	.375	.1250	1.5	RDB-20	15.25
.1250	.500	.1250	1.5	RDB-30	15.25
.1875	.625	.1875	2.0	RDB-40	21.80
.1875	.625	.2500	2.0	RDB-50	24.60
.2500	.750	.2500	2.0	RDB-60	26.20
.2500	.750	.2500	2.5	RDB-70	28.00
.2500	1.000	.2500	3.0	RDB-80	36.70
.3750	1.000	.3750	2.5	RDB-100	64.90
.5000	1.000	.5000	3.0	RDB-110	85.80

*.0005" max TIR

RDC

End Mills For Plastics & Composites

Diamond Cut – End Mill Cut

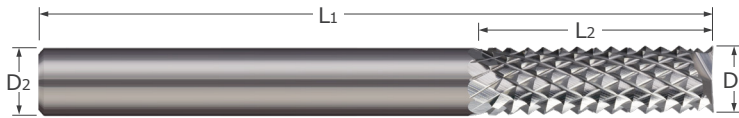

- Ideal for routing fiber reinforced, epoxy resin, and composites
- Diamond-cut flute pattern provides smooth cutting action and reduces delamination
- End mill end cut profile
- Solid carbide ■ CNC ground in the USA

Cutter Diameter*	Length of Cut	Shank Dia.	Overall Length	Uncoated	
				Tool #	Price
D1 $\begin{matrix} +.0000'' \\ -.0030'' \end{matrix}$	L2 $\begin{matrix} +.030'' \\ -.000'' \end{matrix}$	D2 (h6)	L1		
.0938	.375	.1250	1.5	RDC-20	15.25
.1250	.500	.1250	1.5	RDC-30	15.25
.1875	.625	.1875	2.0	RDC-40	21.80
.1875	.625	.2500	2.0	RDC-50	24.60
.2500	.750	.2500	2.0	RDC-60	26.20
.2500	.750	.2500	2.5	RDC-70	28.00
.2500	1.000	.2500	3.0	RDC-80	36.70

*.0005" max TIR

Plastics & Composites

RDD

End Mills For Plastics & Composites

Diamond Cut – 135° Drill Point



- Ideal for routing fiber reinforced, epoxy resin, and composites
- Diamond-cut flute pattern provides smooth cutting action and reduces delamination
- 135° drill point
- Solid carbide ■ CNC ground in the USA

Cutter Diameter*	Length of Cut	Shank Dia.	Overall Length	Uncoated	
				Tool #	Price
D1 $\begin{matrix} +.0000'' \\ -.0030'' \end{matrix}$	L2 $\begin{matrix} +.030'' \\ -.000'' \end{matrix}$	D2 (h6)	L1		
.0625	.188	.1250	1.5	RDD-10	15.25
.0938	.375	.1250	1.5	RDD-20	15.25
.1250	.500	.1250	1.5	RDD-30	15.25
.1875	.625	.1875	2.0	RDD-40	21.80
.1875	.625	.2500	2.0	RDD-50	24.60
.2500	.750	.2500	2.0	RDD-60	26.20
.2500	.750	.2500	2.5	RDD-70	28.00
.2500	1.000	.2500	3.0	RDD-80	36.70
.3125	1.000	.3125	2.5	RDD-90	48.85
.5000	1.000	.5000	3.0	RDD-110	85.80

*.0005" max TIR

End Mills For Plastics & Composites

RDE

Diamond Cut – Fish Tail End Cut

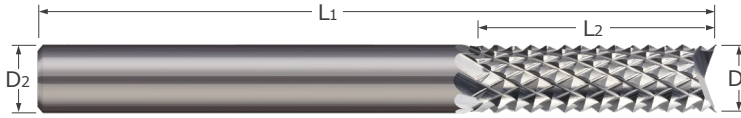

- Ideal for routing fiber reinforced, epoxy resin, and composites
- Diamond-cut flute pattern provides smooth cutting action and reduces delamination
- Less breakout when through-plunging
- Fish tail end cut profile
- Solid carbide
- CNC ground in the USA

Plastics & Composites

Cutter Diameter*	Length of Cut	Shank Dia.	Overall Length	Uncoated	
				Tool #	Price
D1 $+0.0000''$ $-0.0030''$	L2 $+0.030''$ $-0.000''$	D2 (h6)	L1		
.1250	.500	.1250	1.5	RDE-30	15.25
.1875	.625	.1875	2.0	RDE-40	21.80
.1875	.625	.2500	2.0	RDE-50	24.60
.2500	1.000	.2500	3.0	RDE-80	36.70
.3750	1.000	.3750	2.5	RDE-100	64.90
.5000	1.000	.5000	3.0	RDE-110	85.80

*.0005" max TIR

Technical Resources on Micro100.com

Find Simulation Files, Speeds & Feeds, Torque Recommendations, Programs, Blogs, and more at micro100.com/resources



SBM / SBMM

Undercutting End Mills

220°

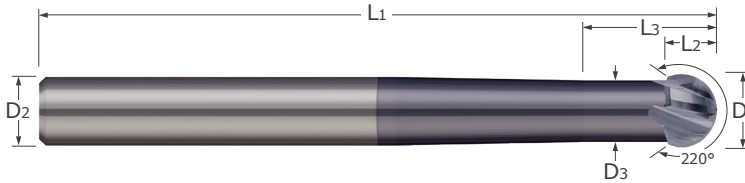

- Designed for undercutting, deburring, and multi-axis machining
- 220° spherical ball
- 30° helix
- Center cutting
- AlTiN coating option for added lubricity and increased wear resistance in difficult-to-machine materials
- Solid carbide ■ CNC ground in the USA

Cutter Diameter*	Length of Cut	Overall Reach	Neck Dia.	Flutes	Shank Dia.	Overall Length	Uncoated		AlTiN Coated	
							Tool #	Price	Tool #	Price
D1 +.0000" +.00mm -.0020" -.05mm	L2 L3	+ .030" -.000" +.78 mm -.00 mm	+ .003" -.005" D3 +.08mm -.13mm		D2 (h6)	L1				
2 mm .0787	1.3 mm	6 mm	1.3 mm	2	6 mm	75 mm			SBMM-020-206X	87.65
2 mm .0787	1.3 mm	6 mm	1.3 mm	4	6 mm	75 mm	SBMM-020-406	82.90	SBMM-020-406X	87.65
2 mm .0787	1.3 mm	10 mm	1.3 mm	2	6 mm	75 mm	SBMM-020-210	82.90	SBMM-020-210X	87.65
2 mm .0787	1.3 mm	10 mm	1.3 mm	4	6 mm	75 mm	SBMM-020-410	82.90	SBMM-020-410X	87.65
2 mm .0787	1.3 mm	16 mm	1.3 mm	2	6 mm	75 mm	SBMM-020-216	82.90	SBMM-020-216X	87.65
2 mm .0787	1.3 mm	16 mm	1.3 mm	3	6 mm	75 mm	SBMM-020-316	82.90	SBMM-020-316X	87.65
2 mm .0787	1.3 mm	16 mm	1.3 mm	4	6 mm	75 mm			SBMM-020-416X	87.65
3 mm .1181	2.0 mm	9 mm	2.0 mm	4	6 mm	75 mm			SBMM-030-409X	87.65
3 mm .1181	2.0 mm	15 mm	2.0 mm	2	6 mm	75 mm	SBMM-030-215	82.90	SBMM-030-215X	87.65
3 mm .1181	2.0 mm	15 mm	2.0 mm	4	6 mm	75 mm	SBMM-030-415	82.90	SBMM-030-415X	87.65
3 mm .1181	2.0 mm	21 mm	2.0 mm	2	6 mm	75 mm	SBMM-030-221	82.90	SBMM-030-221X	87.65
3 mm .1181	2.0 mm	21 mm	2.0 mm	3	6 mm	75 mm	SBMM-030-321	82.90		
3 mm .1181	2.0 mm	21 mm	2.0 mm	4	6 mm	75 mm			SBMM-030-421X	87.65
.1250 .1250	.100	.250	.100	4	.2500	3.0	SBM-125-4	82.90	SBM-125-4X	87.65
4 mm .1575	2.7 mm	12 mm	2.7 mm	2	6 mm	75 mm	SBMM-040-212	82.90	SBMM-040-212X	87.65
4 mm .1575	2.7 mm	12 mm	2.7 mm	4	6 mm	75 mm			SBMM-040-412X	87.65
4 mm .1575	2.7 mm	20 mm	2.7 mm	2	6 mm	75 mm			SBMM-040-220X	87.65
4 mm .1575	2.7 mm	20 mm	2.7 mm	4	6 mm	75 mm	SBMM-040-420	82.90	SBMM-040-420X	87.65
4 mm .1575	2.7 mm	32 mm	2.7 mm	2	6 mm	100 mm	SBMM-040-232	82.90	SBMM-040-232X	87.65
4 mm .1575	2.7 mm	32 mm	2.7 mm	4	6 mm	100 mm	SBMM-040-432	82.90	SBMM-040-432X	87.30
.1875 .1875	.150	.350	.150	4	.2500	3.0	SBM-187-4	82.90	SBM-187-4X	87.65
6 mm .2362	4.0 mm	18 mm	4.0 mm	2	6 mm	75 mm	SBMM-060-218	82.90	SBMM-060-218X	87.65
6 mm .2362	4.0 mm	18 mm	4.0 mm	3	6 mm	75 mm	SBMM-060-318	82.90		
6 mm .2362	4.0 mm	18 mm	4.0 mm	4	6 mm	75 mm	SBMM-060-418	82.90	SBMM-060-418X	87.65
6 mm .2362	4.0 mm	30 mm	4.0 mm	2	6 mm	75 mm			SBMM-060-230X	87.65
6 mm .2362	4.0 mm	30 mm	4.0 mm	4	6 mm	75 mm	SBMM-060-430	82.90	SBMM-060-430X	87.65
6 mm .2362	4.0 mm	32 mm	4.0 mm	2	6 mm	100 mm	SBMM-060-248	82.90	SBMM-060-248X	87.65
6 mm .2362	4.0 mm	32 mm	4.0 mm	3	6 mm	100 mm	SBMM-060-348	82.90	SBMM-060-348X	87.65
6 mm .2362	4.0 mm	32 mm	4.0 mm	4	6 mm	100 mm	SBMM-060-448	82.90	SBMM-060-448X	87.30
.2500 .2500	.200	.500	.200	2	.2500	3.0	SBM-250-2	82.90	SBM-250-2X	87.65
.2500 .2500	.200	.500	.200	3	.2500	3.0	SBM-250-3	82.90	SBM-250-3X	87.65
.2500 .2500	.200	.500	.200	4	.2500	3.0	SBM-250-4	82.90	SBM-250-4X	87.65

*.0005" / .013 mm max TIR

Continued on next page

Undercutting End Mills

Undercutting End Mills

SBM / SBMM

220° (cont.)

Continued from previous page

Cutter Diameter*		Length of Cut		Overall Reach	Neck Dia.	Flutes	Shank Dia.	Overall Length	Uncoated		AITIN Coated	
D1 +.0000" +.00mm -.0030" -.08mm	.3125 .3125	L2	L3	+.030" -.000" +.78 mm -.00 mm	D3 +.003" -.005" +.08mm -.13mm	4	D2 (h6)	L1	Tool #	Price	Tool #	Price
8 mm	.3150	5.4 mm	24 mm	5.4 mm	4	8 mm	100 mm	SBMM-080-424	104.25	SBMM-080-424X	113.60	
8 mm	.3150	5.4 mm	40 mm	5.4 mm	2	8 mm	100 mm	SBMM-080-240	104.25	SBMM-080-240X	113.60	
8 mm	.3150	5.4 mm	40 mm	5.4 mm	3	8 mm	100 mm	SBMM-080-340	104.25	SBMM-080-340X	113.60	
8 mm	.3150	5.4 mm	40 mm	5.4 mm	4	8 mm	100 mm			SBMM-080-440X	113.60	
8 mm	.3150	5.4 mm	55 mm	5.4 mm	2	8 mm	100 mm			SBMM-080-264X	113.60	
8 mm	.3150	5.4 mm	55 mm	5.4 mm	4	8 mm	100 mm			SBMM-080-464X	113.60	
.3750	.3750	.300	.800	.300	2	.3750	4.0			SBM-375-2X	143.20	
.3750	.3750	.300	.800	.300	4	.3750	4.0	SBM-375-4	133.90	SBM-375-4X	143.20	
10 mm	.3937	6.7 mm	30 mm	6.7 mm	2	10 mm	100 mm	SBMM-100-230	140.60			
10 mm	.3937	6.7 mm	30 mm	6.7 mm	4	10 mm	100 mm			SBMM-100-430X	148.70	
10 mm	.3937	6.7 mm	50 mm	6.7 mm	2	10 mm	100 mm	SBMM-100-250	140.60	SBMM-100-250X	148.70	
10 mm	.3937	6.7 mm	50 mm	6.7 mm	4	10 mm	100 mm	SBMM-100-450	140.60	SBMM-100-450X	148.70	
10 mm	.3937	6.7 mm	55 mm	6.7 mm	2	10 mm	100 mm	SBMM-100-272	140.60	SBMM-100-272X	148.70	
10 mm	.3937	6.7 mm	55 mm	6.7 mm	4	10 mm	100 mm	SBMM-100-472	140.60	SBMM-100-472X	148.70	
12 mm	.4724	8.0 mm	36 mm	8.0 mm	2	12 mm	100 mm			SBMM-120-236X	174.40	
12 mm	.4724	8.0 mm	36 mm	8.0 mm	4	12 mm	100 mm	SBMM-120-436	164.40	SBMM-120-436X	174.40	
12 mm	.4724	8.0 mm	55 mm	8.0 mm	4	12 mm	100 mm			SBMM-120-472X	174.40	
.5000	.5000	.400	.900	.400	2	.5000	4.0	SBM-500-2	166.60			
.5000	.5000	.400	.900	.400	4	.5000	4.0	SBM-500-4	166.60	SBM-500-4X	176.60	
.6250	.6250	.500	1.000	.500	2	.6250	4.0	SBM-625-2	207.10	SBM-625-2X	219.10	
.6250	.6250	.500	1.000	.500	3	.6250	4.0	SBM-625-3	207.10	SBM-625-3X	219.10	
.6250	.6250	.500	1.000	.500	4	.6250	4.0			SBM-625-4X	219.10	

*.0005" / .013 mm max TIR

Undercutting End Mills

DM / DMM

Drill/End Mills
2 & 4 Flute

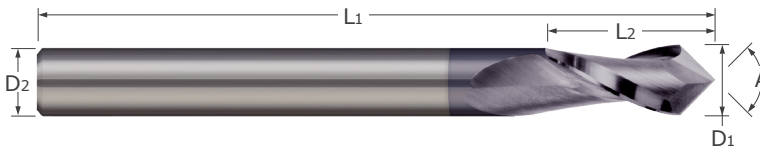

- Designed for chamfering, milling, and some spotting applications
- 2 flute design effective in spotting and drilling applications
- AlTiN coating option for added lubricity and increased wear resistance in difficult-to-machine materials
- 30° helix ■ Solid carbide ■ CNC ground in the USA

Included Angle	Cutter Diameter*	Length of Cut	Flutes	Shank Diameter	Overall Length	Uncoated		AlTiN Coated	
						Tool #	Price	Tool #	Price
$A \pm 1^\circ$	D1	$L2 \begin{matrix} +.030'' \\ -.000'' \\ +.76 \text{ mm} \\ -.00 \text{ mm} \end{matrix}$		D2 (h6)	L1				
90°	3 mm	8 mm	2	3 mm	38 mm	DMM-030-290	18.40	DMM-030-290X	21.00
	3 mm	8 mm	4	3 mm	38 mm	DMM-030-490	19.30	DMM-030-490X	21.90
	.1250	.500	2	.1250	1.5	DM-125-290	18.40	DM-125-290X	21.00
	.1250	.500	4	.1250	1.5	DM-125-490	19.30	DM-125-490X	21.90
	4 mm	11 mm	2	4 mm	50 mm	DMM-040-290	25.75	DMM-040-290X	28.80
	4 mm	11 mm	4	4 mm	50 mm	DMM-040-490	26.80	DMM-040-490X	29.85
	.1875	.625	2	.1875	2.0	DM-187-290	25.75	DM-187-290X	28.80
	.1875	.625	4	.1875	2.0	DM-187-490	26.90	DM-187-490X	29.95
	5 mm	13 mm	2	6 mm	57 mm	DMM-050-290	32.20	DMM-050-290X	37.40
	6 mm	16 mm	2	6 mm	57 mm			DMM-060-290X	37.40
	6 mm	16 mm	4	6 mm	57 mm	DMM-060-490	33.70	DMM-060-490X	38.90
	.2500	.750	2	.2500	2.5	DM-250-290	32.20	DM-250-290X	37.40
	.2500	.750	4	.2500	2.5	DM-250-490	33.70	DM-250-490X	38.90
	.3125	.813	2	.3125	2.5	DM-312-290	40.05	DM-312-290X	47.40
	.3125	.813	4	.3125	2.5	DM-312-490	42.15	DM-312-490X	49.45
	8 mm	22 mm	2	8 mm	63 mm	DMM-080-290	40.05	DMM-080-290X	47.40
	8 mm	22 mm	4	8 mm	63 mm	DMM-080-490	41.85	DMM-080-490X	49.10
	.3750	1.000	2	.3750	2.5	DM-375-290	50.25	DM-375-290X	57.40
	.3750	1.000	4	.3750	2.5	DM-375-490	52.90	DM-375-490X	60.05
	10 mm	25 mm	2	10 mm	72 mm	DMM-100-290	50.25	DMM-100-290X	57.40
	12 mm	30 mm	2	12 mm	83 mm	DMM-120-290	75.95	DMM-120-290X	86.80
	12 mm	30 mm	4	12 mm	83 mm	DMM-120-490	83.10		
	.5000	1.000	2	.5000	3.0	DM-500-290	75.95	DM-500-290X	84.45
	.5000	1.000	4	.5000	3.0	DM-500-490	83.10	DM-500-490X	91.55
	.6250	1.250	2	.6250	3.5	DM-625-290	152.40	DM-625-290X	164.90
	.6250	1.250	4	.6250	3.5	DM-625-490	159.55	DM-625-490X	172.00
	.7500	1.500	2	.7500	4.0	DM-750-290	224.15	DM-750-290X	238.10
	.7500	1.500	4	.7500	4.0	DM-750-490	234.70	DM-750-490X	248.50
20 mm	45 mm	4	20 mm	104 mm			DMM-200-490X	263.90	

* .0005" / .013 mm max TIR. Tolerances for cutter diameters .125"-.250": .000" / -.002"; diameters .313"-.750": .000" / -.003".

Continued on next page

Drill/End Mills

Drill/End Mills

2 & 4 Flute (cont.)

DM / DMM

Continued from previous page

Included Angle	Cutter Diameter*	Length of Cut	Flutes	Shank Diameter	Overall Length	Uncoated		AITIN Coated	
						Tool #	Price	Tool #	Price
A $+1^{\circ}$ -1°	D1	L2 $+0.030''$ $-0.000''$ $+0.76$ mm -0.00 mm		D2 (h6)	L1				
120°	3 mm	8 mm	2	3 mm	38 mm	DMM-030-2120	18.40		
	3 mm	8 mm	4	3 mm	38 mm	DMM-030-4120	19.30	DMM-030-4120X	21.90
	.1250	.500	2	.1250	1.5			DM-125-2120X	21.00
	.1250	.500	4	.1250	1.5	DM-125-4120	19.30	DM-125-4120X	21.90
	4 mm	11 mm	2	4 mm	50 mm	DMM-040-2120	25.75	DMM-040-2120X	28.80
	4 mm	11 mm	4	4 mm	50 mm	DMM-040-4120	26.80		
	.1875	.625	2	.1875	2.0	DM-187-2120	25.75	DM-187-2120X	28.80
	.1875	.625	4	.1875	2.0	DM-187-4120	26.90	DM-187-4120X	29.95
	5 mm	13 mm	2	6 mm	57 mm			DMM-050-2120X	37.40
	5 mm	13 mm	4	6 mm	57 mm	DMM-050-4120	33.70		
	6 mm	16 mm	2	6 mm	57 mm	DMM-060-2120	32.20		
	.2500	.750	2	.2500	2.5	DM-250-2120	32.20	DM-250-2120X	37.40
	.2500	.750	4	.2500	2.5	DM-250-4120	33.70	DM-250-4120X	38.90
	.3125	.813	2	.3125	2.5	DM-312-2120	40.05	DM-312-2120X	47.40
	.3125	.813	4	.3125	2.5	DM-312-4120	42.15	DM-312-4120X	49.45
	8 mm	22 mm	2	8 mm	63 mm	DMM-080-2120	40.05		
	8 mm	22 mm	4	8 mm	63 mm	DMM-080-4120	41.85	DMM-080-4120X	49.10
	.3750	1.000	2	.3750	2.5	DM-375-2120	50.25	DM-375-2120X	57.40
	.3750	1.000	4	.3750	2.5	DM-375-4120	52.90	DM-375-4120X	60.05
	10 mm	25 mm	2	10 mm	72 mm	DMM-100-2120	50.25		
	10 mm	25 mm	4	10 mm	72 mm	DMM-100-4120	52.35		
	12 mm	30 mm	2	12 mm	83 mm	DMM-120-2120	75.95		
	.5000	1.000	2	.5000	3.0	DM-500-2120	75.95	DM-500-2120X	84.45
	.5000	1.000	4	.5000	3.0	DM-500-4120	83.10	DM-500-4120X	91.55
	.6250	1.250	2	.6250	3.5			DM-625-2120X	164.90
	.6250	1.250	4	.6250	3.5	DM-625-4120	159.55	DM-625-4120X	172.00
	16 mm	35 mm	4	16 mm	92 mm	DMM-160-4120	159.10	DMM-160-4120X	171.55
	.7500	1.500	2	.7500	4.0	DM-750-2120	224.15	DM-750-2120X	238.10
.7500	1.500	4	.7500	4.0	DM-750-4120	234.70			

* .0005" / .013 mm max TIR. Tolerances for cutter diameters .125"-.250": .000" / -.002"; diameters .313"-.750": .000" / -.003".

Drill/End Mills

CS

Chamfer Cutters

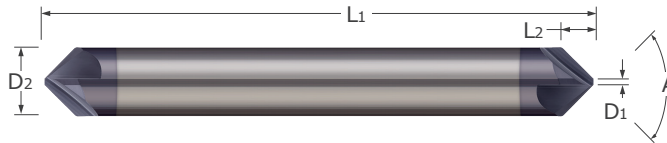

- Designed for chamfer milling, countersinking, and deburring
- Double-ended
- Available in 60°, 82°, 90°, 100°, and 120° included angles
- Tip Diameter (D1) is non-cutting
- Multi-tooth for greater metal removal rates
- AlTiN coating option for added lubricity and increased wear resistance in difficult-to-machine materials
- Solid carbide
- CNC ground in the USA

Included Angle	Tip Diameter	Length of Cut	Flutes	Shank Diameter	Overall Length	Uncoated		AlTiN Coated	
						Tool #	Price	Tool #	Price
A $+1^\circ$ -1°	D1 $+0.001$ -0.003	L2		D2 (h6)	L1				
60°	.030	.082	3	.1250	1.5	CS-125-060	27.20	CS-125-060X	31.05
	.040	.128	4	.1875	2.0			CS-187-060X	36.95
	.050	.173	6	.2500	2.5	CS-250-060	35.45	CS-250-060X	43.90
	.060	.219	6	.3125	2.5	CS-312-060	49.60	CS-312-060X	62.05
	.070	.264	6	.3750	2.5	CS-375-060	56.65	CS-375-060X	68.60
	.080	.364	6	.5000	3.0	CS-500-060	82.25	CS-500-060X	96.75
82°	.030	.055	3	.1250	1.5	CS-125-082	27.20	CS-125-082X	31.05
	.040	.085	4	.1875	2.0			CS-187-082X	36.95
	.050	.115	6	.2500	2.5	CS-250-082	35.45	CS-250-082X	43.90
	.060	.145	6	.3125	2.5	CS-312-082	49.60	CS-312-082X	62.05
	.070	.175	6	.3750	2.5	CS-375-082	56.65	CS-375-082X	68.60
	.080	.242	6	.5000	3.0	CS-500-082	82.25	CS-500-082X	96.75
90°	.030	.047	3	.1250	1.5	CS-125-090	27.20	CS-125-090X	31.05
	.040	.074	4	.1875	2.0	CS-187-090	32.35	CS-187-090X	36.95
	.050	.100	6	.2500	2.5	CS-250-090	35.45	CS-250-090X	43.90
	.060	.126	6	.3125	2.5	CS-312-090	49.60	CS-312-090X	62.05
	.070	.152	6	.3750	2.5	CS-375-090	56.65	CS-375-090X	68.60
	.080	.210	6	.5000	3.0	CS-500-090	82.25	CS-500-090X	96.75
100°	.030	.040	3	.1250	1.5	CS-125-100	27.20	CS-125-100X	31.05
	.040	.062	4	.1875	2.0	CS-187-100	32.35	CS-187-100X	36.95
	.050	.084	6	.2500	2.5	CS-250-100	35.45	CS-250-100X	43.90
	.060	.106	6	.3125	2.5	CS-312-100	49.60	CS-312-100X	62.05
	.070	.128	6	.3750	2.5	CS-375-100	56.65	CS-375-100X	68.60
	.080	.176	6	.5000	3.0	CS-500-100	82.25	CS-500-100X	96.75
120°	.030	.027	3	.1250	1.5	CS-125-120	27.20	CS-125-120X	31.05
	.050	.058	6	.2500	2.5	CS-250-120	35.45	CS-250-120X	43.90
	.060	.073	6	.3125	2.5			CS-312-120X	62.05
	.070	.088	6	.3750	2.5			CS-375-120X	68.60
	.080	.121	6	.5000	3.0			CS-500-120X	96.75

Chamfer Cutters

Chamfer Cutters

Back Chamfer Cutters

MBC

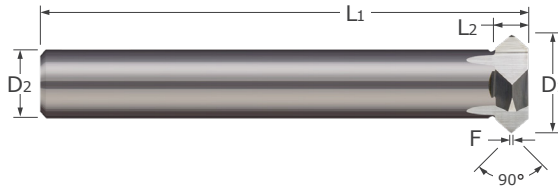

- 90° included angle for chamfer milling the top and bottom of a part
- Multiple flutes for improved finish and increased metal removal rates
- Cuts on angle only
- Solid carbide head brazed on a carbide shank
- CNC ground in the USA

Cutter Diameter	Cutter Width	Flat	Flutes	Shank Diameter	Overall Length	Uncoated	
						Tool #	Price
D1 $\begin{smallmatrix} +.000" \\ -.005" \end{smallmatrix}$	L2 $\begin{smallmatrix} +.000" \\ -.015" \end{smallmatrix}$	F $\begin{smallmatrix} +.000" \\ -.005" \end{smallmatrix}$		D2 (h6)	L1		
.375	.125	.031	4	.2500	2.63	MBC-375	83.00
.500	.125	.031	5	.3125	2.63	MBC-500	101.20
.750	.156	.031	6	.3750	2.66	MBC-750	125.55
1.000	.188	.031	7	.5000	3.19	MBC-001	163.80

Chamfer Cutters

Runner Cutters

MRF / MRT

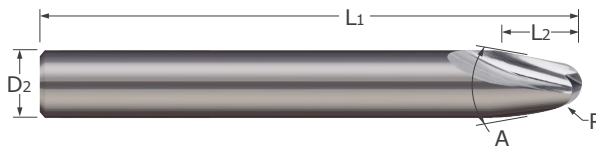

- Designed to mill 20° and 30° channels in molds
- 2 helical flutes
- Center cutting
- Solid carbide
- CNC ground in the USA

Included Angle	Radius	Length of Cut	Flutes	Shank Diameter	Overall Length	Uncoated	
						Tool #	Price
A $\begin{smallmatrix} +1° \\ -1° \end{smallmatrix}$	R $\begin{smallmatrix} +.0030" \\ -.0000" \end{smallmatrix}$	L2		D2 (h6)	L1		
20°	.0312	.383	2	.1875	2.0	MRT-187-031	43.20
	.0469	.308	2	.1875	2.0	MRT-187-046	43.20
	.0625	.414	2	.2500	2.5	MRT-250-062	47.90
	.0938	.437	2	.3125	2.5	MRT-312-093	58.25
	.1094	.366	2	.3125	2.5	MRT-312-109	58.25
	.1250	.468	2	.3750	2.5	MRT-375-125	61.25
30°	.0312	.262	2	.1875	2.0	MRF-187-031	43.20
	.0625	.287	2	.2500	2.5	MRF-250-062	47.90
	.0781	.243	2	.2500	2.5	MRF-250-078	47.90
	.1094	.270	2	.3125	2.5	MRF-312-109	58.25

**RTC / RTCM / RSC
RSCM / RNC / RNCM**

Engraving Cutters
Tipped Off – Single Ended

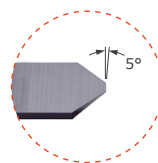
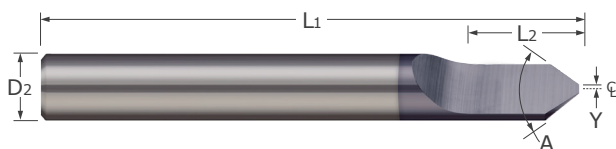

- Designed for engraving and v-grooving in various applications
- Tipped off end diameter for improved cutting
- Point offset (Y) represents half of flat generated in workpiece (Workpiece Flat = 2Y)
- Half round style
- Relieved for right hand milling
- AlTiN coating option for added lubricity and increased wear resistance in difficult-to-machine materials
- Solid carbide ■ CNC ground in the USA

Included Angle	Shank Diameter	Point Offset	Split Length	Overall Length	Uncoated		AlTiN Coated		
					Tool #	Price	Tool #	Price	
30°	D2 (h6)	Y	L2	L1					
		+ .001" - .001" + .02 mm - .02 mm	+ .015" - .000" + .38 mm - .00 mm						
		3 mm	0.10 mm	7 mm	38 mm	RTCM-030-1	14.80	RTCM-030-1X	17.50
		.1250	.004	.375	1.5	RTC-125-1	20.30	RTC-125-1X	21.70
		.1250	.004	.375	3.0	RTC-125-13	20.90	RTC-125-13X	23.15
		4 mm	0.10 mm	10 mm	50 mm	RTCM-040-1	18.90	RTCM-040-1X	22.05
		.1875	.004	.437	2.0	RTC-187-1	25.20		
		5 mm	0.10 mm	12 mm	50 mm	RTCM-050-1	21.50		
		6 mm	0.10 mm	12 mm	57 mm	RTCM-060-1	22.85	RTCM-060-1X	28.15
		.2500	.004	.500	2.5	RTC-250-1	27.25	RTC-250-1X	37.50
		.2500	.004	.500	4.0	RTC-250-14	39.70		
		.2500	.010	.500	2.5	RTC-250-120	26.30		
		.2500	.015	.500	2.5	RTC-250-130	32.65		
		.2500	.022	.500	2.5	RTC-250-145	34.50		
		.2500	.030	.500	2.5	RTC-250-160	34.50		
		.3125	.004	.500	2.5	RTC-312-1	50.95		
		.3125	.004	.500	4.0	RTC-312-14	63.95		
		8 mm	0.10 mm	12 mm	63 mm	RTCM-080-1	36.70	RTCM-080-1X	44.00
	.3750	.004	.500	2.5	RTC-375-1	63.75			
	12 mm	0.10 mm	14 mm	83 mm			RTCM-120-1X	87.55	
60°	D2 (h6)	Y	L2	L1					
		+ .001" - .001" + .02 mm - .02 mm	+ .015" - .000" + .38 mm - .00 mm						
		3 mm	0.10 mm	5 mm	38 mm	RSCM-030-1	14.80	RSCM-030-1X	17.50
		.1250	.004	.375	1.5	RSC-125-1	20.00	RSC-125-1X	21.00
		.1250	.004	.375	3.0	RSC-125-13	21.30		
		4 mm	0.10 mm	6 mm	50 mm	RSCM-040-1	18.90	RSCM-040-1X	22.05
		.1875	.004	.375	2.0	RSC-187-1	24.40	RSC-187-1X	30.70
		.1875	.004	.375	3.0	RSC-187-13	25.95		
		5 mm	0.10 mm	7 mm	50 mm			RSCM-050-1X	25.90
		6 mm	0.10 mm	8 mm	57 mm	RSCM-060-1	22.85	RSCM-060-1X	28.15
		.2500	.004	.375	2.5	RSC-250-1	29.05		
		.2500	.004	.375	4.0	RSC-250-14	43.20		
		.2500	.010	.375	2.5	RSC-250-120	28.85	RSC-250-120X	37.50
		.2500	.015	.375	2.5	RSC-250-130	32.10		
		.2500	.022	.375	2.5	RSC-250-145	34.50		

Engraving Cutters

Engraving Cutters

Tipped Off – Single Ended (cont.)

**RTC / RTCM / RSC
RSCM / RNC / RNCM**

Continued from previous page

Included Angle	Shank Diameter	Point Offset	Split Length	Overall Length	Uncoated		AlTiN Coated	
					Tool #	Price	Tool #	Price
A $+0^{\circ}30'$ $-0^{\circ}30'$	D2 (h6)	Y $+0.01"$ $-0.01"$ $+0.02$ mm -0.02 mm	L2 $+0.015"$ $-0.000"$ $+0.38$ mm -0.00 mm	L1				
60°	.2500	.030	.375	2.5	RSC-250-160	34.50		
	.3125	.004	.500	2.5	RSC-312-1	50.70		
	.3125	.004	.500	4.0	RSC-312-14	63.95		
	8 mm	0.10 mm	10 mm	63 mm	RSCM-080-1	36.70	RSCM-080-1X	44.00
	.3750	.004	.500	2.5	RSC-375-1	62.50	RSC-375-1X	71.20
	.3750	.004	.500	4.0	RSC-375-14	90.40		
	10 mm	0.10 mm	12 mm	72 mm	RSCM-100-1	54.05	RSCM-100-1X	61.15
	12 mm	0.10 mm	14 mm	83 mm	RSCM-120-1	75.90		
.5000	.004	.625	3.0	RSC-500-1	99.70	RSC-500-1X	104.50	
90°	3 mm	0.10 mm	5 mm	38 mm	RNCM-030-1	14.80	RNCM-030-1X	17.50
	.1250	.004	.375	1.5	RNC-125-1	18.80	RNC-125-1X	25.95
	.1250	.004	.375	3.0	RNC-125-13	24.60		
	4 mm	0.10 mm	6 mm	50 mm	RNCM-040-1	18.90	RNCM-040-1X	22.05
	.1875	.004	.375	2.0	RNC-187-1	26.45	RNC-187-1X	24.25
	.1875	.004	.375	3.0	RNC-187-13	27.55	RNC-187-13X	32.85
	5 mm	0.10 mm	7 mm	50 mm	RNCM-050-1	21.50	RNCM-050-1X	25.65
	6 mm	0.10 mm	8 mm	57 mm	RNCM-060-1	22.85	RNCM-060-1X	28.15
	.2500	.004	.375	2.5	RNC-250-1	30.15	RNC-250-1X	31.20
	.2500	.004	.375	4.0	RNC-250-14	36.60	RNC-250-14X	46.25
	.2500	.015	.375	2.5	RNC-250-130	34.50		
	.2500	.022	.375	2.5	RNC-250-145	34.50		
	.2500	.030	.375	2.5	RNC-250-160	34.50		
	.3125	.004	.500	2.5	RNC-312-1	41.10		
	8 mm	0.10 mm	10 mm	63 mm	RNCM-080-1	36.70	RNCM-080-1X	44.00
	.3750	.004	.500	2.5	RNC-375-1	60.00	RNC-375-1X	68.70
	10 mm	0.10 mm	12 mm	72 mm	RNCM-100-1	54.05		
	12 mm	0.10 mm	14 mm	83 mm	RNCM-120-1	75.90	RNCM-120-1X	86.75
.5000	.004	.625	3.0	RNC-500-1	97.10			

Engraving Cutters

**RTC / RTCM / RSC
RSCM / RNC / RNCM**

Engraving Cutters
Tipped Off – Doubled Ended

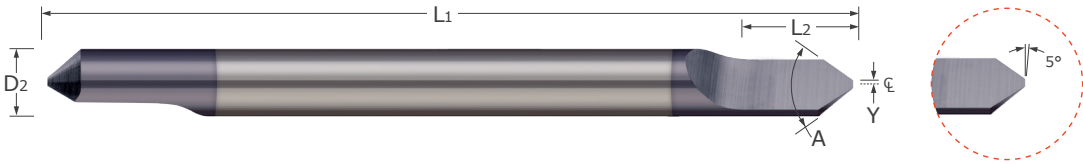

- Designed for engraving and v-grooving in various applications
- Tipped off end diameter for improved cutting
- Point offset (Y) represents half of flat generated in workpiece (Workpiece Flat = 2Y)
- Double ended
- Half round drill style
- Relieved for right hand milling
- AlTiN coating option for added lubricity and increased wear resistance in difficult-to-machine materials
- Solid carbide ■ CNC ground in the USA

Included Angle	Shank Diameter	Point Offset	Split Length	Overall Length	Uncoated		AlTiN Coated	
					Tool #	Price	Tool #	Price
A $+0^{\circ}30'$ $-0^{\circ}30'$	D2 (h6)	Y $+0.001"$ $-0.001"$ $+0.02$ mm -0.02 mm	L2 $+0.015"$ $-0.015"$ $+0.38$ mm -0.38 mm	L1				
30°	3 mm	0.10 mm	7 mm	38 mm	RTCM-030-2	19.75	RTCM-030-2X	23.65
	.1250	.004	.375	2.0	RTC-125-2	23.80	RTC-125-2X	31.90
	.1250	.004	.375	3.0	RTC-125-23	29.75	RTC-125-23X	37.35
	4 mm	0.10 mm	10 mm	50 mm	RTCM-040-2	25.25	RTCM-040-2X	29.85
	.1875	.004	.437	2.0	RTC-187-2	31.30	RTC-187-2X	39.45
	.1875	.004	.437	3.0	RTC-187-23	36.20	RTC-187-23X	45.05
	5 mm	0.10 mm	12 mm	50 mm	RTCM-050-2	28.45	RTCM-050-2X	33.00
	6 mm	0.10 mm	12 mm	57 mm	RTCM-060-2	31.10	RTCM-060-2X	39.60
	.2500	.004	.500	2.5	RTC-250-2	36.50	RTC-250-2X	46.05
	.2500	.004	.500	4.0	RTC-250-24	50.70		
	.2500	.010	.500	2.5	RTC-250-220	38.60	RTC-250-220X	46.85
	.2500	.015	.500	2.5	RTC-250-230	33.70		
	.2500	.022	.500	2.5	RTC-250-245	43.10	RTC-250-245X	51.15
	.2500	.030	.500	2.5	RTC-250-260	43.10		
	.3125	.004	.500	2.5	RTC-312-2	63.95		
	.3125	.004	.500	4.0	RTC-312-24	77.90		
8 mm	0.10 mm	12 mm	63 mm	RTCM-080-2	49.30	RTCM-080-2X	61.45	
.3750	.004	.500	2.5	RTC-375-2	79.40			
.3750	.004	.500	4.0	RTC-375-24	100.50			
10 mm	0.10 mm	12 mm	72 mm	RTCM-100-2	70.45			
.5000	.004	.625	3.0	RTC-500-2	109.00			
60°	3 mm	0.10 mm	5 mm	38 mm	RSCM-030-2	19.75	RSCM-030-2X	23.65
	.1250	.004	.375	2.0	RSC-125-2	24.85	RSC-125-2X	29.30
	.1250	.004	.375	3.0	RSC-125-23	29.45		
	4 mm	0.10 mm	6 mm	50 mm	RSCM-040-2	25.25	RSCM-040-2X	29.85
	.1875	.004	.375	2.0	RSC-187-2	30.15	RSC-187-2X	35.20
	.1875	.004	.375	3.0	RSC-187-23	37.50		
	5 mm	0.10 mm	7 mm	50 mm			RSCM-050-2X	32.30
	6 mm	0.10 mm	8 mm	57 mm	RSCM-060-2	31.10	RSCM-060-2X	39.60
	.2500	.004	.375	2.5	RSC-250-2	37.90	RSC-250-2X	48.25

Continued on next page

Engraving Cutters

Tipped Off – Doubled Ended (cont.)

RTC / RTCM / RSC
RSCM / RNC / RNCM

Continued from previous page

Included Angle	Shank Diameter	Point Offset	Split Length	Overall Length	Uncoated		AITIN Coated	
					Tool #	Price	Tool #	Price
A $+0^{\circ}30'$ $-0^{\circ}30'$	D ₂ (h6)	Y $+0.001"$ $-0.001"$ $+0.02$ mm -0.02 mm	L ₂ $+0.015"$ $-0.015"$ $+0.38$ mm -0.38 mm	L ₁				
60°	.2500	.004	.375	4.0	RSC-250-24	55.25		
	.2500	.010	.375	2.5	RSC-250-220	38.20	RSC-250-220X	48.60
	.2500	.015	.375	2.5	RSC-250-230	39.10		
	.2500	.030	.375	2.5	RSC-250-260	43.10		
	.3125	.004	.500	2.5	RSC-312-2	65.45	RSC-312-2X	68.10
	.3125	.004	.500	4.0	RSC-312-24	77.90		
	.3750	.004	.500	2.5	RSC-375-2	76.10	RSC-375-2X	90.90
	.3750	.004	.500	4.0	RSC-375-24	99.80		
	10 mm	0.10 mm	12 mm	72 mm	RSCM-100-2	70.45	RSCM-100-2X	82.35
.5000	.004	.625	3.0	RSC-500-2	116.90			
90°	3 mm	0.10 mm	5 mm	38 mm	RNCM-030-2	19.75	RNCM-030-2X	23.65
	.1250	.004	.375	2.0	RNC-125-2	25.20	RNC-125-2X	33.85
	.1250	.004	.375	3.0	RNC-125-23	30.75	RNC-125-23X	38.35
	4 mm	0.10 mm	6 mm	50 mm	RNCM-040-2	25.25	RNCM-040-2X	29.85
	.1875	.004	.375	2.0	RNC-187-2	31.20	RNC-187-2X	36.60
	.1875	.004	.375	3.0	RNC-187-23	36.75		
	5 mm	0.10 mm	7 mm	50 mm	RNCM-050-2	28.45		
	6 mm	0.10 mm	8 mm	57 mm	RNCM-060-2	31.10	RNCM-060-2X	39.60
	.2500	.004	.375	2.5	RNC-250-2	38.70	RNC-250-2X	46.95
	.2500	.004	.375	4.0	RNC-250-24	50.70	RNC-250-24X	61.80
	.2500	.010	.375	2.5	RNC-250-220	38.30	RNC-250-220X	48.75
	.2500	.015	.375	2.5	RNC-250-230	40.00	RNC-250-230X	50.40
	.2500	.030	.375	2.5	RNC-250-260	43.10		
	.3125	.004	.500	2.5	RNC-312-2	62.40		
	.3125	0.004	.500	4.0	RNC-312-24	77.90	RNC-312-24X	91.25
	8 mm	0.10 mm	10 mm	63 mm	RNCM-080-2	49.30	RNCM-080-2X	61.45
	.3750	.004	.500	2.5	RNC-375-2	78.80	RNC-375-2X	93.60
	.3750	.004	.500	4.0	RNC-375-24	98.20		
	.5000	.004	.625	3.0	RNC-500-2	114.45	RNC-500-2X	131.00
.5000	.004	.625	4.0	RNC-500-24	164.35			

Engraving Cutters

KC

Keyseat Cutters
Square

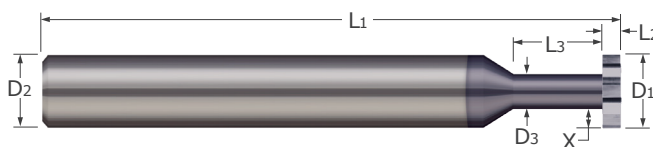

- Keyseat cutters down to .093" diameter
- Both sides of cutter are dished for clearance
- Standard and long length styles
- AlTiN coating option for added lubricity and increased wear resistance in difficult-to-machine materials
- Solid carbide ■ CNC ground in the USA

Cutter Diameter	Cutter Width	Neck Diameter	Radial Depth of Cut	Neck Length	Flutes	Shank Diameter	Overall Length	Uncoated		AlTiN Coated	
								Tool #	Price	Tool #	Price
$D1 \begin{smallmatrix} +.0000" \\ -.0020" \end{smallmatrix}$	$L2 \begin{smallmatrix} +.001" \\ -.000" \end{smallmatrix}$	$D3 \begin{smallmatrix} +.000" \\ -.002" \end{smallmatrix}$	X	$L3 \begin{smallmatrix} +.010" \\ -.000" \end{smallmatrix}$		D2 (h6)	L1				
.0938	.010	.047	.019	.140	4	.1250	1.5	KC-093-140-010	43.50	KC-093-140-010X	45.90
.0938	.015	.047	.019	.140	4	.1250	1.5	KC-093-140-015	41.15	KC-093-140-015X	43.55
.0938	.020	.047	.019	.140	4	.1250	1.5	KC-093-140-020	41.15		
.0938	.040	.047	.019	.140	4	.1250	1.5	KC-093-140-040	41.15		
.1250	.015	.062	.028	.190	6	.1250	1.5	KC-125-190-015	41.15	KC-125-190-015X	43.55
.1250	.025	.062	.028	.190	6	.1250	1.5	KC-125-190-025	41.15		
.1250	.030	.062	.028	.190	6	.1250	1.5	KC-125-190-030	41.15		
.1250	.030	.062	.028	.375	6	.1250	1.5			KC-125-375-030X	43.55
.1250	.040	.062	.028	.190	6	.1250	1.5	KC-125-190-040	41.15	KC-125-190-040X	43.55
.1250	.045	.062	.028	.190	6	.1250	1.5	KC-125-190-045	41.15	KC-125-190-045X	43.55
.1250	.050	.062	.028	.190	6	.1250	1.5	KC-125-190-050	41.15		
.1250	.055	.062	.028	.190	6	.1250	1.5			KC-125-190-055X	43.55
.1250	.060	.062	.028	.190	6	.1250	1.5	KC-125-190-060	41.15	KC-125-190-060X	43.55
.1250	.062	.062	.028	.190	6	.1250	1.5	KC-125-190-062	41.15	KC-125-190-062X	43.55
.1250	.062	.062	.028	.375	6	.1250	1.5	KC-125-375-062	41.15		
.1250	.093	.062	.028	.190	6	.1250	1.5	KC-125-190-093	41.15	KC-125-190-093X	43.55
.1250	.093	.062	.028	.375	6	.1250	1.5	KC-125-375-093	41.15		
.1875	.025	.090	.045	.300	6	.1875	2.0	KC-187-300-025	43.50		
.1875	.029	.090	.045	.300	6	.1875	2.0	KC-187-300-029	43.50	KC-187-300-029X	46.40
.1875	.040	.090	.045	.300	6	.1875	2.0	KC-187-300-040	43.50		
.1875	.045	.090	.045	.300	6	.1875	2.0			KC-187-300-045X	46.40
.1875	.050	.090	.045	.300	6	.1875	2.0	KC-187-300-050	43.50		
.1875	.093	.090	.045	.300	6	.1875	2.0	KC-187-300-093	43.50		
.1875	.093	.090	.045	.550	6	.1875	2.0	KC-187-550-093	43.50	KC-187-550-093X	46.40
.1875	.125	.090	.045	.550	6	.1875	2.0	KC-187-550-125	43.50	KC-187-550-125X	46.40
.3750	.035	.190	.089	.600	8	.3750	2.5	KC-375-600-035	67.30		
.3750	.125	.190	.089	1.125	8	.3750	2.5			KC-375-1125-125X	74.30
.3750	.156	.190	.089	.600	8	.3750	2.5	KC-375-600-156	67.30		
.3750	.156	.190	.089	1.125	8	.3750	2.5			KC-375-1125-156X	74.30
.3750	.187	.190	.089	1.125	8	.3750	2.5	KC-375-1125-187	67.30	KC-375-1125-187X	74.30

Keyseat Cutters

Continued on next page

Keyseat Cutters

KC

Square (cont.)

Continued from previous page

Cutter Diameter	Cutter Width	Neck Diameter	Radial Depth of Cut	Neck Length	Flutes	Shank Diameter	Overall Length	Uncoated		AlTiN Coated	
								Tool #	Price	Tool #	Price
$D_1 \begin{smallmatrix} +.000" \\ -.002" \end{smallmatrix}$	$L_2 \begin{smallmatrix} +.001" \\ -.000" \end{smallmatrix}$	$D_3 \begin{smallmatrix} +.000" \\ -.002" \end{smallmatrix}$	X	$L_3 \begin{smallmatrix} +.010" \\ -.000" \end{smallmatrix}$		D2 (h6)	L1				
.5000	.030	.250	.121	.750	8	.5000	3.0	KC-500-750-030	86.85		
.5000	.062	.250	.121	1.500	8	.5000	3.0	KC-500-1500-062	98.25		
.5000	.093	.250	.121	1.500	8	.5000	3.0	KC-500-1500-093	98.25		
.5000	.103	.250	.121	.750	8	.5000	3.0	KC-500-750-103	86.85		
.5000	.118	.250	.121	.750	8	.5000	3.0			KC-500-750-118X	95.30
.5000	.118	.250	.121	1.500	8	.5000	3.0	KC-500-1500-118	98.25		
.5000	.120	.250	.121	.750	8	.5000	3.0	KC-500-750-120	86.85	KC-500-750-120X	95.30
.5000	.125	.250	.121	1.500	8	.5000	3.0	KC-500-1500-125	98.25		
.5000	.156	.250	.121	.750	8	.5000	3.0	KC-500-750-156	86.85		
.5000	.156	.250	.121	1.500	8	.5000	3.0	KC-500-1500-156	98.25		
.5000	.187	.250	.121	.750	8	.5000	3.0	KC-500-750-187	86.85		
.5000	.187	.250	.121	1.500	8	.5000	3.0			KC-500-1500-187X	106.60

Keyseat Cutters



Build & Send Shopping Carts Directly to Your Distributor or Purchasing Agent

Create Your Micro100 Account Today at Micro100.com

CREM

Corner Rounding End Mills 3 Flute – Single Ended

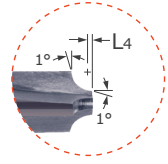
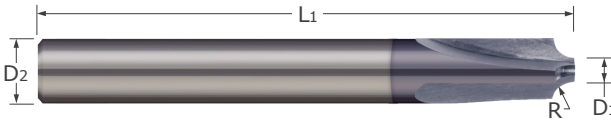

- Designed to mill corner radii into a part
- 1° max flares tangent at pilot and shoulder to avoid steps and burrs
- Cuts on radius only
- AlTiN coating option for added lubricity and increased wear resistance in difficult-to-machine materials
- Solid carbide ■ CNC ground in the USA

Minor Diameter	Radius	Max Lead in Length	Shank Diameter	Overall Length	Uncoated		AlTiN Coated	
					Tool #	Price	Tool #	Price
D1 $\begin{matrix} +.000 \text{ mm} \\ -.076 \text{ mm} \end{matrix}$	R $\begin{matrix} +.000 \text{ mm} \\ -.013 \text{ mm} \end{matrix}$	L4	D2 (h6)	L1				
1.5 mm	0.3 mm	.13 mm	6 mm	57 mm	CREM-060-030	42.00	CREM-060-030X	47.05
1.5 mm	0.5 mm	.13 mm	6 mm	57 mm			CREM-060-050X	47.05
1.5 mm	0.8 mm	.13 mm	6 mm	57 mm	CREM-060-080	42.00		
1.5 mm	1.0 mm	.13 mm	6 mm	57 mm	CREM-060-100	42.00	CREM-060-100X	47.05
1.5 mm	1.5 mm	.13 mm	6 mm	57 mm	CREM-060-150	42.00	CREM-060-150X	47.05
1.5 mm	2.0 mm	.13 mm	6 mm	57 mm	CREM-060-200	42.00	CREM-060-200X	47.05
1.5 mm	2.5 mm	.13 mm	8 mm	63 mm			CREM-080-250X	57.65
1.5 mm	3.0 mm	.13 mm	8 mm	63 mm	CREM-080-300	50.45	CREM-080-300X	57.65
1.5 mm	4.0 mm	.13 mm	10 mm	73 mm	CREM-100-400	68.60	CREM-100-400X	75.60

Corner Rounding End Mills

3 Flute – Double Ended

CRE

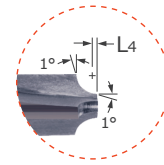
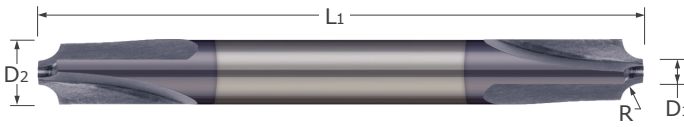

- Designed to mill corner radii into a part
- 1° max flares tangent at pilot and shoulder to avoid steps and burrs
- Cuts on radius only
- Double-ended
- AlTiN coating option for added lubricity and increased wear resistance in difficult-to-machine materials
- Solid carbide ■ CNC ground in the USA

Minor Diameter	Radius	Max Lead in Length	Shank Diameter	Overall Length	Uncoated		AlTiN Coated	
					Tool #	Price	Tool #	Price
$D1^{+.000"}_{-.002"}$	$R^{+.0000"}_{-.0005"}$	L4	D2 (h6)	L1				
.060	.0100	.005	.1250	2.0	CRE-125-010	37.40	CRE-125-010X	41.15
.060	.0156	.005	.1250	2.0	CRE-125-015	37.40	CRE-125-015X	41.15
.060	.0200	.005	.1250	2.0	CRE-125-020	37.40	CRE-125-020X	41.15
.060	.0250	.005	.1250	2.0	CRE-125-025	37.40	CRE-125-025X	41.15
.060	.0300	.005	.1250	2.0	CRE-125-030	37.40	CRE-125-030X	41.15
.060	.0312	.005	.1250	2.0	CRE-125-031	37.40	CRE-125-031X	41.15
.060	.0350	.005	.1875	2.0	CRE-187-035	40.35	CRE-187-035X	44.90
.060	.0400	.005	.1875	2.0	CRE-187-040	40.35	CRE-187-040X	44.90
.060	.0450	.005	.1875	2.0	CRE-187-045	40.35	CRE-187-045X	44.90
.060	.0469	.005	.1875	2.0	CRE-187-047	40.35	CRE-187-047X	44.90
.060	.0500	.005	.1875	2.0	CRE-187-050	40.35	CRE-187-050X	44.90
.060	.0550	.005	.1875	2.0	CRE-187-055	40.35	CRE-187-055X	44.90
.060	.0600	.005	.1875	2.0	CRE-187-060	40.35	CRE-187-060X	44.90
.060	.0625	.005	.1875	2.0	CRE-187-062	40.35	CRE-187-062X	44.90

Minor Diameter	Radius	Max Lead in Length	Shank Diameter	Overall Length	Uncoated		AlTiN Coated	
					Tool #	Price	Tool #	Price
$D1^{+.000"}_{-.003"}$	$R^{+.0000"}_{-.0005"}$	L4	D2 (h6)	L1				
.060	.0700	.005	.2500	2.5	CRE-250-070	52.20	CRE-250-070X	59.35
.060	.0750	.005	.2500	2.5	CRE-250-075	52.20	CRE-250-075X	59.35
.060	.0781	.005	.2500	2.5	CRE-250-078	52.20	CRE-250-078X	59.35
.060	.0800	.005	.2500	2.5	CRE-250-080	52.20	CRE-250-080X	59.35
.060	.0900	.005	.2500	2.5	CRE-250-090	52.20	CRE-250-090X	59.35
.060	.0938	.005	.2500	2.5	CRE-250-093	52.20	CRE-250-093X	59.35
.060	.1000	.005	.3125	2.5	CRE-312-100	63.05	CRE-312-100X	75.45
.060	.1094	.005	.3125	2.5	CRE-312-109	63.05	CRE-312-109X	75.45
.060	.1250	.005	.3125	2.5	CRE-312-125	63.05	CRE-312-125X	75.45
.060	.1406	.005	.3750	2.5	CRE-375-140	85.70	CRE-375-140X	97.35
.060	.1562	.005	.3750	2.5	CRE-375-156	85.70	CRE-375-156X	97.35
.120	.1718	.010	.5000	3.0	CRE-500-171	132.75	CRE-500-171X	145.55
.120	.1875	.010	.5000	3.0	CRE-500-187	132.75	CRE-500-187X	145.55
.120	.2031	.010	.6250	3.5	CRE-625-203	142.30	CRE-625-203X	163.55
.120	.2188	.010	.6250	3.5	CRE-625-218	142.30	CRE-625-218X	163.55
.120	.2344	.010	.6250	3.5	CRE-625-234	142.30	CRE-625-234X	163.55
.120	.2500	.010	.6250	3.5	CRE-625-250	142.30	CRE-625-250X	163.55
.120	.2812	.010	.7500	4.0	CRE-750-281	199.60		
.120	.3125	.010	.7500	4.0	CRE-750-312	199.60	CRE-750-312X	224.05
.120	.3750	.010	1.0000	4.0	CRE-001-375	372.45	CRE-001-375X	405.55
.120	.4370	.010	1.0000	4.0	CRE-001-437	372.45	CRE-001-437X	405.55

Corner Rounding End Mills

DT

Dovetail Cutters

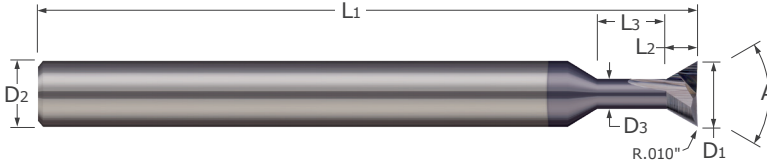

- Designed to mill dovetail grooves into a part
- Offered with 30°, 60°, and 90° included angles
- AlTiN coating option for added lubricity and increased wear resistance in difficult-to-machine materials
- Solid carbide
- CNC ground in the USA

Included Angle	Cutter Diameter*	Length of Cut	Neck Diameter	Neck Length	Corner Radius	Flutes	Shank Diameter	Overall Length	Uncoated		AlTiN Coated	
									Tool #	Price	Tool #	Price
30°	$D_1^{+.0000" / -.0020"}$	L2	D3	$L_3^{+.030" / -.000"}$	R		D2 (h6)	L1				
	.1250	.095	.080	.125	.010	2	.1250	1.5	DT-125-030-010	59.00	DT-125-030-010X	61.20
	.1875	.127	.125	.125	.010	2	.1875	2.0	DT-187-030-010	63.05	DT-187-030-010X	65.70
	.2500	.161	.170	.125	.010	2	.2500	2.5	DT-250-030-010	79.50	DT-250-030-010X	84.25
	.3125	.221	.200	.312	.010	2	.3125	2.5	DT-312-030-010	86.05	DT-312-030-010X	93.40
	.3750	.263	.240	.375	.010	3	.3750	2.5	DT-375-030-010	90.85	DT-375-030-010X	97.65
	.5000	.347	.320	.500	.010	3	.5000	3.0	DT-500-030-010	117.80	DT-500-030-010X	126.00
60°	.1250	.065	.065	.125	.010	2	.1250	1.5	DT-125-060-010	59.00	DT-125-060-010X	61.20
	.1875	.093	.095	.125	.010	2	.1875	2.0	DT-187-060-010	63.05	DT-187-060-010X	65.70
	.2500	.125	.120	.125	.010	2	.2500	2.5	DT-250-060-010	79.50	DT-250-060-010X	84.25
	.3125	.162	.140	.312	.010	2	.3125	2.5	DT-312-060-010	86.05	DT-312-060-010X	93.40
	.3750	.190	.170	.375	.010	3	.3750	2.5	DT-375-060-010	90.85	DT-375-060-010X	97.65
	.5000	.255	.220	.500	.010	3	.5000	3.0	DT-500-060-010	117.80	DT-500-060-010X	126.00
90°	.1250	.042	.070	.125	.010	2	.1250	1.5	DT-125-090-010	59.00	DT-125-090-010X	61.20
	.1875	.048	.120	.125	.010	2	.1875	2.0	DT-187-090-010	63.05	DT-187-090-010X	65.70
	.2500	.064	.150	.125	.010	2	.2500	2.5	DT-250-090-010	79.50	DT-250-090-010X	84.25
	.3125	.095	.150	.312	.010	2	.3125	2.5	DT-312-090-010	86.05	DT-312-090-010X	93.40
	.3750	.127	.150	.375	.010	3	.3750	2.5	DT-375-090-010	90.85	DT-375-090-010X	97.65
	.5000	.164	.200	.500	.010	3	.5000	3.0	DT-500-090-010	117.80	DT-500-090-010X	126.00

* .0005" max TIR

Indexable Milling – Tool Holders

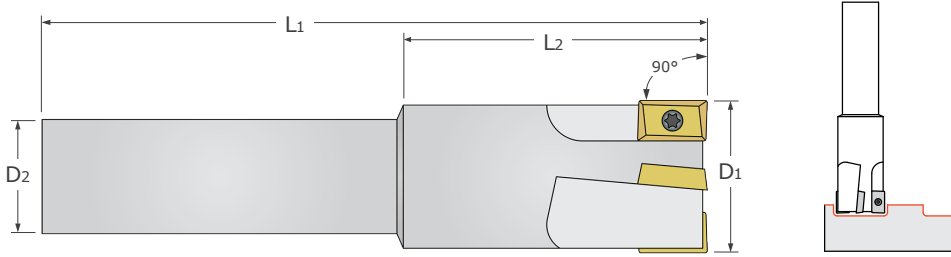

- 90° orientation angle allows for square shoulder cutting
- Utilizes ANSI standard APKT style inserts (not included)
- Each tool holder includes a M2.5 x T-8 torx screw and torx key (part # 16-1020)
- Non coolant-through
- Insert not included

Cutter Diameter	Body Length	Flutes	Shank Diameter	Overall Length	Insert Part Number	Holder Nomenclature	Tool Holder	
D ₁	L ₂		D ₂	L ₁			Tool #	Price
.375	1.500	1	.5000	3.0	50-2100	BAAP 1216 2	31-1216	116.60
.500	1.500	1	.5000	3.0	50-2100	BAAP 1616 2	31-1616	130.25
.625	1.500	2	.5000	3.0	50-2100	BAAP 1816 2	31-1816	143.95
.750	2.000	3	.7500	4.4	50-2100	BAAP 2424 2	31-2424	198.75
1.000	2.000	4	.7500	4.4	50-2100	BAAP 3224 2	31-3224	212.40
1.250	2.000	5	.7500	4.4	50-2100	BAAP 4024 2	31-4024	316.55

See pg 318 for indexable insert accessories

Indexable Milling – Tool Holders – Coolant Through

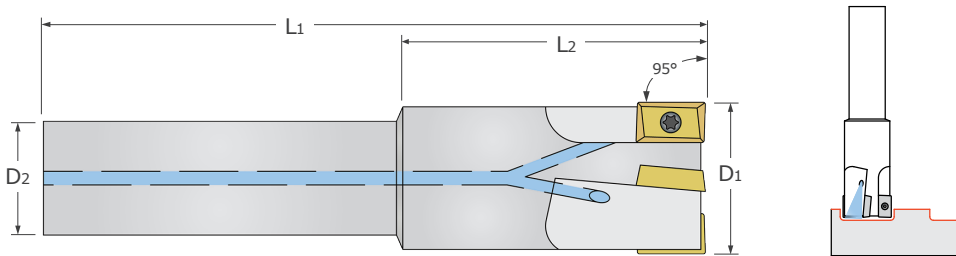

- Coolant-through milling tool holders designed to enhance chip evacuation
- 90° orientation angle allows for square shoulder cutting
- Utilizes ANSI standard APKT style inserts (not included)
- Each tool holder includes a M2.5 x T-8 torx screw and torx key (part # 16-1020)
- Insert not included

Cutter Diameter	Body Length	Flutes	Shank Diameter	Overall Length	Insert Part Number	Holder Nomenclature	Tool Holder	
D ₁	L ₂		D ₂	L ₁			Tool #	Price
.375	1.500	1	.5000	3.0	50-2100	AAAP 1216 2	30-1216	143.95
.500	1.500	1	.5000	3.0	50-2100	AAAP 1616 2	30-1616	157.55
.625	1.500	2	.5000	3.0	50-2100	AAAP 1816 2	30-1816	172.05
.750	2.000	3	.7500	4.4	50-2100	AAAP 2424 2	30-2424	202.60
1.000	2.000	4	.7500	4.4	50-2100	AAAP 3224 2	30-3224	324.80
1.250	2.000	5	.7500	4.4	50-2100	AAAP 4024 2	30-4024	348.10

See pg 318 for indexable insert accessories

See pg 317 for tool set options

BLANKS SETS & ACCESSORIES

Blanks	300
--------	-----

Sets	306
------	-----

Accessories	318
-------------	-----

Blanks

Half Round

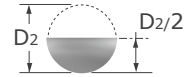
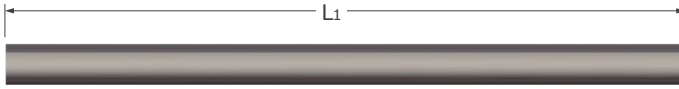

Blanks

- Half round style carbide blanks
- Polished split face
- Solid carbide
- CNC Ground in the USA

Split Height		Shank Diameter	Overall Length	Half Round Blank	
$D_2/2$	decimal equiv.	D_2	L_1	Tool #	Price
1 mm	.0394	2 mm	38 mm	HRM-020-38	16.65
1.5 mm	.0591	3 mm	38 mm	HRM-030-38	17.55
2.5 mm	.0984	5 mm	50 mm	HRM-050-50	29.20
3 mm	.1181	6 mm	57 mm	HRM-060-57	34.95
.1250	.1250	.2500	2.5	HR-250	42.55
4 mm	.1575	8 mm	63 mm	HRM-080-63	57.50
5 mm	.1969	10 mm	72 mm	HRM-100-72	81.05

SR / SRM

Blanks
Round Blanks

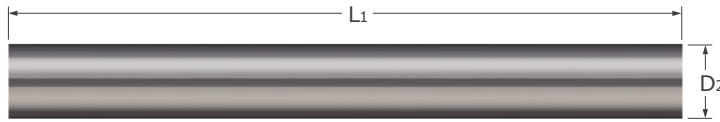

- Round style
- Finish ground blanks
- Solid carbide
- CNC ground in the USA

Shank Diameter		Overall Length	Round Blank	
D2(h6)		L1	Tool #	Price
1 mm	.0394	30 mm	SRM-010-030	5.30
1 mm	.0394	310 mm	SRM-010-310	14.75
1.5 mm	.0591	100 mm	SRM-015-100	7.20
.0625	.0625	1.0	SR-062-1	7.75
.0625	.0625	2.0	SR-062-2	7.65
.0625	.0625	3.0	SR-062-3	7.55
.0625	.0625	4.0	SR-062-4	7.20
.0625	.0625	12.0	SR-062-12	20.00
2 mm	.0787	38 mm	SRM-020-038	5.90
2 mm	.0787	100 mm	SRM-020-100	9.10
2 mm	.0787	310 mm	SRM-020-310	19.90
.0938	.0938	1.0	SR-093-1	8.55
.0938	.0938	3.0	SR-093-3	10.00
.0938	.0938	4.0	SR-093-4	12.35
.0938	.0938	6.0	SR-093-6	12.70
.0938	.0938	12.0	SR-093-12	18.55
2.5 mm	.0984	100 mm	SRM-025-100	9.10
3 mm	.1181	38 mm	SRM-030-038	6.50
3 mm	.1181	100 mm	SRM-030-100	10.90
3 mm	.1181	310 mm	SRM-030-310	26.60
.1250	.1250	1.5	SR-125-1.5	7.00
.1250	.1250	2.0	SR-125-2	7.65
.1250	.1250	3.0	SR-125-3	9.20
.1250	.1250	4.0	SR-125-4	11.65
.1250	.1250	6.0	SR-125-6	17.75
.1250	.1250	12.0	SR-125-12	30.20
3.5 mm	.1378	100 mm	SRM-035-100	15.25
.1562	.1562	1.5	SR-156-1.5	8.30
.1562	.1562	2.0	SR-156-2	10.55
.1562	.1562	3.0	SR-156-3	13.75
.1562	.1562	4.0	SR-156-4	15.85
.1562	.1562	6.0	SR-156-6	27.50
.1562	.1562	12.0	SR-156-12	38.75

*Denotes chamfered end.

Continued on next page

Blanks

Round Blanks (cont.)

Continued from previous page

Blanks

Shank Diameter		Overall Length	Round Blank	
D2(h6)		L1	Tool #	Price
4 mm	.1575	50 mm	SRM-040-050	7.55
4 mm	.1575	100 mm	SRM-040-100	15.55
4 mm	.1575	310 mm	SRM-040-310	38.10
4.5 mm	.1772	100 mm	SRM-045-100	18.35
.1875	.1875	1.5	SR-187-1.5*	8.65
.1875	.1875	2.0	SR-187-2*	10.00
.1875	.1875	4.0	SR-187-4	19.25
.1875	.1875	6.0	SR-187-6	27.75
.1875	.1875	12.0	SR-187-12	49.85
5 mm	.1969	50 mm	SRM-050-050	9.45
5 mm	.1969	100 mm	SRM-050-100	21.15
5 mm	.1969	310 mm	SRM-050-310	61.00
5.5 mm	.2165	100 mm	SRM-055-100	23.15
6 mm	.2362	57 mm	SRM-060-057	14.25
6 mm	.2362	100 mm	SRM-060-100	28.10
6 mm	.2362	310 mm	SRM-060-310	72.25
.2500	.2500	2.0	SR-250-2*	14.75
.2500	.2500	2.5	SR-250-2.5*	17.55
.2500	.2500	3.0	SR-250-3*	18.35
.2500	.2500	4.0	SR-250-4	28.00
.2500	.2500	6.0	SR-250-6	40.10
.2500	.2500	12.0	SR-250-12	74.75
7 mm	.2756	100 mm	SRM-070-100	37.10
.3125	.3125	2.0	SR-312-2*	18.75
.3125	.3125	2.5	SR-312-2.5*	22.70
.3125	.3125	4.0	SR-312-4*	41.15
.3125	.3125	6.0	SR-312-6	57.20
.3125	.3125	12.0	SR-312-12	103.25
8 mm	.3150	100 mm	SRM-080-100	37.50
8 mm	.3150	310 mm	SRM-080-310	97.75
9 mm	.3543	100 mm	SRM-090-100	38.45
9 mm	.3543	310 mm	SRM-090-310	117.40
.3750	.3750	2.0	SR-375-2*	22.90
.3750	.3750	2.5	SR-375-2.5*	28.20
.3750	.3750	4.0	SR-375-4*	46.05
.3750	.3750	6.0	SR-375-6	70.10
.3750	.3750	12.0	SR-375-12	134.05
10 mm	.3937	72 mm	SRM-100-072	34.05
10 mm	.3937	100 mm	SRM-100-100	56.20
10 mm	.3937	310 mm	SRM-100-310	158.65
.4375	.4375	2.5	SR-437-2.5*	56.75
.4375	.4375	4.0	SR-437-4	83.95
.4375	.4375	6.0	SR-437-6	128.55
.4375	.4375	12.0	SR-437-12	198.10
12 mm	.4724	83 mm	SRM-120-083	52.95

*Denotes chamfered end.

Continued on next page

SR / SRM

Blanks

Round Blanks (cont.)

Continued from previous page

Shank Diameter			Overall Length	Round Blank	
D ₂ (h6)			L ₁	Tool #	Price
	12 mm	.4724	100 mm	SRM-120-100	73.85
	12 mm	.4724	310 mm	SRM-120-310	210.90
.5000		.5000	2.5	SR-500-2.5*	44.25
.5000		.5000	3.0	SR-500-3*	46.55
.5000		.5000	4.0	SR-500-4	71.15
.5000		.5000	6.0	SR-500-6	108.55
.5000		.5000	12.0	SR-500-12	244.50
	13 mm	.5118	310 mm	SRM-130-310	214.80
	14 mm	.5512	100 mm	SRM-140-100	105.75
.5625		.5625	3.5	SR-562-3.5*	89.30
.6250		.6250	3.5	SR-625-3.5*	110.45
.6250		.6250	4.0	SR-625-4	110.75
.6250		.6250	6.0	SR-625-6	161.35
.6250		.6250	12.0	SR-625-12	307.65
	16 mm	.6299	100 mm	SRM-160-100	108.85
	16 mm	.6299	310 mm	SRM-160-310	311.80
.6875		.6875	6.0	SR-687-6	320.80
	18 mm	.7087	100 mm	SRM-180-100	148.90
.7500		.7500	4.0	SR-750-4*	132.15
.7500		.7500	6.0	SR-750-6	252.90
.7500		.7500	12.0	SR-750-12	413.80
	20 mm	.7874	100 mm	SRM-200-100	160.90
	25 mm	.9843	310 mm	SRM-250-310	695.40
1.0000		1.0000	5.0	SR-001-5*	429.90
1.0000		1.0000	6.0	SR-001-6	460.25
1.0000		1.0000	12.0	SR-001-12	719.30

*Denotes chamfered end.

Blanks

Split End – Single Ended

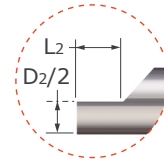
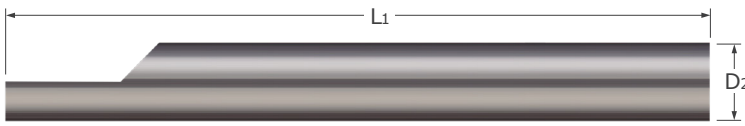

Blanks

- Precision ground blank designed for custom profiles requiring a split face
- Precision manufactured in the USA

Split Length*			Shank Diameter	Overall Length	Single-Ended Blank	
L2 +.015" -.000"	+1.0 mm -0.0 mm	decimal equiv.	D2 (h6)	L1	Tool #	Price
					4 mm	.1575
6 mm	.2362	4 mm	50 mm	RSM-040-1	13.60	
8 mm	.3150	6 mm	57 mm	RSM-060-1	19.90	
.375	.3750	.1250	1.5	RS-125-1	17.05	
.375	.3750	.1250	3.0	RS-125-13	19.25	
.375	.3750	.1875	2.0	RS-187-1	20.80	
.375	.3750	.1875	3.0	RS-187-13	28.50	
.375	.3750	.2500	2.5	RS-250-1	26.85	
.375	.3750	.2500	4.0	RS-250-14	42.45	
10 mm	.3937	8 mm	63 mm	RSM-080-1	37.30	
12 mm	.4724	10 mm	72 mm	RSM-100-1	49.35	
.500	.5000	.3125	2.5	RS-312-1	40.10	
.500	.5000	.3125	4.0	RS-312-14	61.10	
.500	.5000	.3750	2.5	RS-375-1	52.45	
.500	.5000	.3750	4.0	RS-375-14	82.95	
.625	.6250	.5000	3.0	RS-500-1	89.30	
.625	.6250	.5000	4.0	RS-500-14	122.70	

* Centerline +.0010" / -.0000" and +.024 mm / -.000 mm

RS /RSM

Blanks

Split End – Double Ended

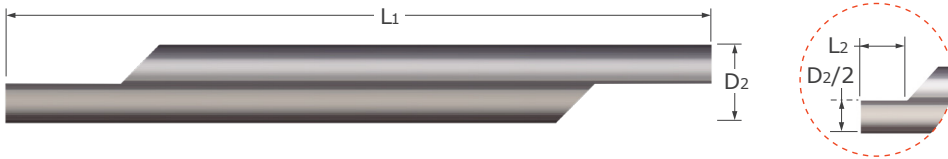

- Precision ground blank designed for custom profiles requiring a split face
- Double-ended allows for maximum utilization of the blank
- Precision manufactured in the USA

Split Length*			Shank Diameter	Overall Length	Double-Ended Blank	
L_2					Tool #	Price
$+.015"$ $-.015"$	$+1.0$ mm -0.0 mm	decimal equiv.	D_2 (h6)	L_1		
	4 mm	.1575	2 mm	38 mm	RSM-020-2	13.60
	5 mm	.1969	3 mm	38 mm	RSM-030-2	14.45
	6 mm	.2362	4 mm	50 mm	RSM-040-2	17.95
	8 mm	.3150	6 mm	57 mm	RSM-060-2	26.50
.375		.3750	.1250	2.0000	RS-125-2	23.60
.375		.3750	.1250	3.0000	RS-125-23	25.40
.375		.3750	.1875	2.0000	RS-187-2	28.80
.375		.3750	.1875	3.0000	RS-187-23	35.50
.375		.3750	.2500	2.5000	RS-250-2	36.40
.375		.3750	.2500	4.0000	RS-250-24	50.00
	10 mm	.3937	8 mm	63 mm	RSM-080-2	47.65
	12 mm	.4724	10 mm	72 mm	RSM-100-2	66.40
.500		.5000	.3125	2.5000	RS-312-2	53.35
.500		.5000	.3125	4.0000	RS-312-24	74.95
.500		.5000	.3750	2.5000	RS-375-2	65.85
.500		.5000	.3750	4.0000	RS-375-24	98.30
.625		.6250	.5000	3.0000	RS-500-2	105.85
.625		.6250	.5000	4.0000	RS-500-24	151.60

* Centerline $+.0010"$ / $-.0000"$ and $+.024$ mm / $-.000$ mm

Sets

Standard – Boring Tools – Right Hand – Sharp – Miniature

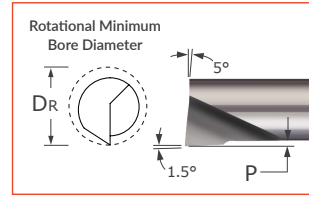
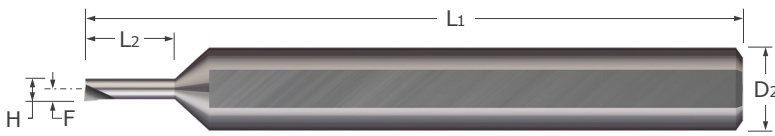

- Designed for facing and boring applications in bores .015" and larger
- Polished face for improved edge retention and chip evacuation while reducing galling
- Split geometry makes the tool as rigid as possible
- On center neck design allows for static and live/rotating applications
- Sharp corner profile
- Lockdown flat automatically locates tool on center
- AlTiN coated option provides added lubricity and increased wear resistance in difficult to machine materials
- Solid carbide
- CNC ground in the USA



Head Width	Rotational Minimum Bore Diameter	Maximum Bore Depth	Projection	Centerline Offset		Shank Dia.	OAL	Uncoated	Set	
				F				Tool #	Set #	Price
H	DR	$L_2 \begin{smallmatrix} +.010'' \\ -.000'' \end{smallmatrix}$	P	F	D ₂ (h6)	L ₁				
.0180	.020	.075	.0020	.0100	.1250	1.5		MBB-020075	MBB-0	209.00
.0225	.025	.100	.0025	.0125	.1250	1.5		MBB-025100		
.0275	.030	.100	.0025	.0150	.1250	1.5		MBB-030100		
.0320	.035	.100	.0030	.0175	.1250	1.5		MBB-035100		
.0365	.040	.150	.0035	.0200	.1250	1.5		MBB-040150		
.0405	.045	.150	.0045	.0225	.1250	1.5		MBB-045150		

Sent Directly to Your Inbox

Valuable information about Micro 100 products and technical resources directly to your inbox. Be the first to know of newly-released tools to gain an immediate leg-up on the competition!



Sets

Standard – Boring Tools – Right Hand

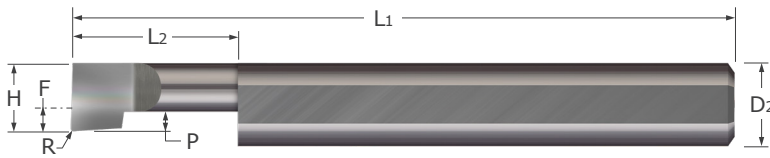

- Designed for facing and boring applications in bores .050" and larger
- Polished split face for improved edge retention and chip evacuation while reducing galling
- Split geometry makes the tool as rigid as possible
- Corner radius profile
- Lockdown flat automatically locates tool on center
- Coating options provide added lubricity and increased wear resistance in difficult to machine materials
- Solid carbide ■ CNC ground in the USA

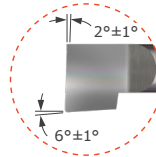

Shank Dia.	Head Width	Minimum Bore Dia.*	Maximum Bore Depth	Radius	Projection	Centerline Offset	Overall Length	Uncoated	Set	
D ₂ (h6)	H	L ₂	R	P	F	L ₁	Tool #	Set #	Price	
1/8	.050	.060	.300	.003	.012	-.0125	1.5	BB-050300	BB-1	160.00
	.060	.070	.300	.003	.015	-.0025	1.5	BB-060300		
	.080	.090	.300	.003	.020	.0175	1.5	BB-080300		
	.100	.110	.400	.003	.025	.0375	1.5	BB-100400		
	.100	.110	.500	.003	.025	.0375	1.5	BB-100500		
3/16	.100	.110	.600	.003	.025	.0375	1.5	BB-100600	BB-2	169.00
	.120	.132	.500	.006	.030	.0263	2.0	BB-120500		
	.120	.132	.700	.006	.030	.0263	2.0	BB-120700		
	.140	.152	.400	.006	.035	.0463	2.0	BB-140400		
	.140	.152	.700	.006	.035	.0463	2.0	BB-140700		
1/4	.160	.176	.400	.006	.040	.0663	2.0	BB-160400	BB-3	183.00
	.160	.176	.750	.006	.040	.0663	2.0	BB-160750		
	.180	.196	.500	.006	.045	.0550	2.5	BB-180500		
	.180	.196	.750	.006	.045	.0550	2.5	BB-180750		
	.180	.196	1.000	.006	.045	.0550	2.5	BB-1801000		
5/16	.200	.216	.400	.006	.050	.0750	2.5	BB-200400	BB-4	246.00
	.200	.216	.600	.006	.050	.0750	2.5	BB-200600		
	.200	.216	1.000	.006	.050	.0750	2.5	BB-2001000		
	.230	.250	.400	.006	.057	.0738	2.5	BB-230400		
	.230	.250	.600	.006	.057	.0738	2.5	BB-230600		
3/8	.230	.250	.800	.006	.057	.0738	2.5	BB-230800	BB-5	335.00
	.230	.250	1.000	.006	.057	.0738	2.5	BB-2301000		
	.290	.310	.500	.006	.072	.1338	2.5	BB-290500		
	.290	.310	1.000	.006	.072	.1338	2.5	BB-2901000		
	.320	.340	.500	.006	.080	.1325	2.5	BB-320500		
3/8	.320	.340	1.000	.006	.080	.1325	2.5	BB-3201000	BB-5	335.00
	.320	.340	1.500	.006	.080	.1325	2.5	BB-3201500		
	.360	.380	.750	.006	.090	.1725	2.5	BB-360750		
	.360	.380	1.250	.006	.090	.1725	2.5	BB-3601250		
	.360	.380	1.800	.006	.090	.1725	2.5	BB-3601800		

*Suggested Minimum Bore Diameter to accommodate chip evacuation and retract clearance in static (not live) applications.



Sets

Standard – Grooving Tools – Retaining Ring – Right Hand

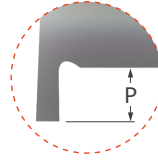
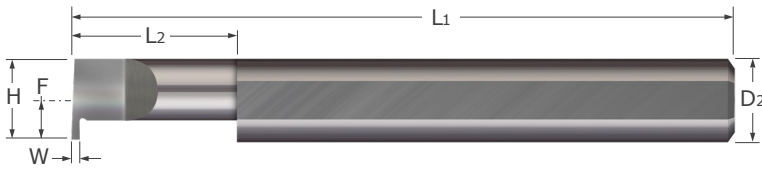

- Designed for generating retaining ring grooves
- Polished split face for improved edge retention and chip evacuation while reducing galling
- Sharp corner profile
- Lockdown flat automatically locates tool on center
- Coating options provide added lubricity and increased wear resistance in difficult to machine materials
- Solid carbide ■ CNC ground in the USA

Width	Head Width	Min. Bore Diameter*	Max. Bore Depth	Projection	Centerline Offset	Shank Diameter	Overall Length	Uncoated	Set	
$W \begin{smallmatrix} +.001'' \\ -.000'' \end{smallmatrix}$	H		$L_2 \begin{smallmatrix} +.050'' \\ -.000'' \end{smallmatrix}$	P	F	$D_2 (h6)$	L_1	Tool #	Set #	Price
.017	.250	.272	.250	.050	.1250	.2500	2.5	RR-017-4	RR-1	231.00
.025	.250	.272	.625	.050	.1250	.2500	2.5	RR-025-10		
.030	.250	.272	.500	.050	.1250	.2500	2.5	RR-030-8		
.030	.250	.272	.625	.050	.1250	.2500	2.5	RR-030-10		
.033	.312	.334	.500	.100	.1562	.3125	2.5	RR-033-8		
.033	.312	.334	.750	.100	.1562	.3125	2.5	RR-033-12		
$W \begin{smallmatrix} +.002'' \\ -.000'' \end{smallmatrix}$	H		$L_2 \begin{smallmatrix} +.050'' \\ -.000'' \end{smallmatrix}$	P	F	$D_2 (h6)$	L_1	Tool #	Set #	Price
.039	.375	.397	.750	.100	.1875	.3750	2.5	RR-039-12	RR-2	347.00
.046	.375	.397	1.000	.100	.1875	.3750	2.5	RR-046-16		
.055	.375	.397	1.250	.100	.1875	.3750	2.5	RR-055-20		
.062	.375	.397	.750	.100	.1875	.3750	2.5	RR-062-12		
.087	.375	.397	.750	.100	.1875	.3750	2.5	RR-087-12		
.087	.375	.397	1.250	.100	.1875	.3750	2.5	RR-087-20		

*Suggested Minimum Bore Diameter to accommodate chip evacuation and retract clearance in static (not live) applications.

Sets

Standard – Threading Tools – UN Threads – Single Point – Right Hand

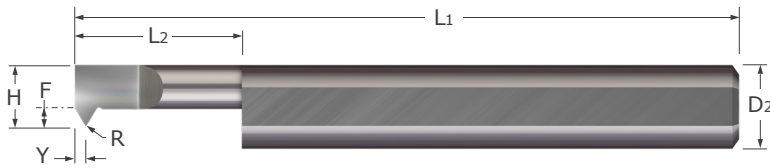

- Designed for threading multiple thread pitches (ANSI, UN, and Metric 60°)
- Polished split face for improved edge retention and chip evacuation while reducing galling
- Split geometry makes the tool as rigid as possible
- Corner radius profile
- Lockdown flat automatically locates tool on center
- AlTiN coated option provides added lubricity and increased wear resistance in difficult to machine materials
- Solid carbide ■ CNC ground in the USA

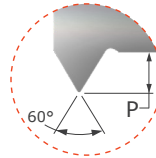

Threads Per Inch	Head Width	Minimum Bore Diameter*	Maximum Bore Depth	Point Offset	Projection	Radius	Centerline Offset	Shank Diameter	Overall Length	Uncoated	Set	
										Tool #	Set #	Price
TPI	H		L2	Y	P	R	F	D2 (h6)	L1			
			$^{+.050}_{-.000}$ "	$^{+.010}_{-.000}$ "		$^{+.001}_{-.000}$ "						
24-56	.180	.202	.500	.023	.040	.002	.0550	.2500	2.5	IT-180500	IT-1	291.00
24-40	.200	.222	.600	.026	.045	.002	.0750	.2500	2.5	IT-200600		
20-40	.230	.252	.600	.032	.055	.002	.0738	.3125	2.5	IT-230600		
14-40	.290	.312	.750	.040	.070	.002	.1338	.3125	2.5	IT-290750		
10-32	.320	.342	.750	.043	.075	.002	.1325	.3750	2.5	IT-320750		
10-32	.360	.382	.750	.049	.085	.002	.1725	.3750	2.5	IT-360750		

*Suggested Minimum Bore Diameter to accommodate chip evacuation and retract clearance in static (not live) applications.



Sets Standard – Boring Tools – Right Hand – Brazed

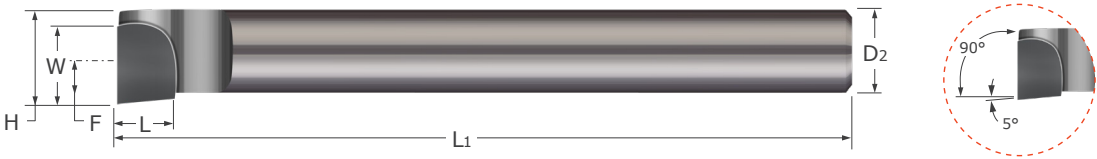

- Designed for right hand facing and boring applications in bores .320" and larger
- Long shank enables flexible reach options (preset at any length)
- Sharp corner profile
- Solid carbide tipped with zinc coated steel shank for durability and corrosion resistance
- CNC ground in the USA

Head Width	Width	Length	Centerline Offset	Shank Diameter	Overall Length	Brazed Style	Set	
H	W	L	F	D2 $\begin{smallmatrix} +.000" \\ -.003" \end{smallmatrix}$	L1	Tool #	Set #	Price
.320	.250	.188	.195	.250	4.0	TBB-250	TBB-5	158.00
.463	.313	.250	.276	.375	6.0	TBB-375		
.625	.500	.250	.375	.500	7.0	TBB-500		
.795	.500	.250	.483	.625	8.0	TBB-625		
.935	.625	.250	.560	.750	9.0	TBB-750		

Sets Standard – Boring Tools – Left Hand – Brazed

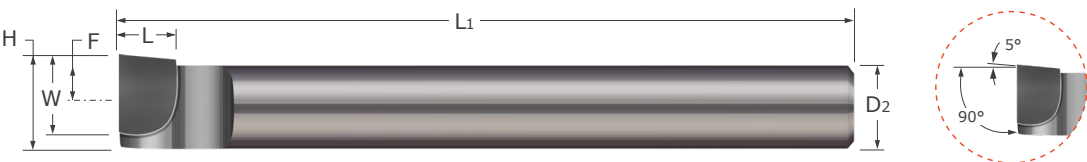

- Designed for left hand facing and boring applications in bores .320" and larger
- Long shank enables flexible reach options (preset at any length)
- Sharp corner profile
- Solid carbide tipped with zinc coated steel shank for durability and corrosion resistance
- CNC ground in the USA

Head Width	Width	Length	Centerline Offset	Shank Diameter	Overall Length	Brazed Style	Set	
H	W	L	F	D2 $\begin{smallmatrix} +.000" \\ -.003" \end{smallmatrix}$	L1	Tool #	Set #	Price
.320	.250	.188	.195	.250	4.0	TBBL-250	TBBL-5	154.00
.463	.313	.250	.276	.375	6.0	TBBL-375		
.625	.500	.250	.375	.500	7.0	TBBL-500		
.795	.500	.250	.483	.625	8.0	TBBL-625		
.935	.625	.250	.560	.750	9.0	TBBL-750		

Brazed – Forming Tools – 90° Radius Concave – Right Hand



- Right hand tool designed for forming a convex radius
- Tangential 5° blend angles aid in providing a burr-free transition
- Solid carbide tipped with zinc coated steel shank for durability and corrosion resistance
- Available in industry standard fractional shank sizes
- Ground in the USA

Radius	Square Shank	Overall Length	Brazed	Set	
$R_{\begin{smallmatrix} +.0005'' \\ -.0005'' \end{smallmatrix}}$	$A_{\begin{smallmatrix} +.0000'' \\ -.0050'' \end{smallmatrix}}$	C	Tool #	Set #	Price
.0625	.3750	2.5	RAD-2	RAD-21	192.00
.1250	.3750	2.5	RAD-4		
.2500	.3750	2.5	RAD-8		
.3750	.5000	3.5	RAD-12		
.0312	.3750	2.5	RAD-1	RAD-22	388.00
.0625	.3750	2.5	RAD-2		
.0938	.3750	2.5	RAD-3		
.1250	.3750	2.5	RAD-4		
.1562	.3750	2.5	RAD-5		
.1875	.3750	2.5	RAD-6		
.2188	.3750	2.5	RAD-7		
.2500	.3750	2.5	RAD-8		
.0625	.3750	2.5	RAD-2	RAD-23	418.00
.1250	.3750	2.5	RAD-4		
.1875	.3750	2.5	RAD-6		
.2500	.3750	2.5	RAD-8		
.3125	.5000	3.5	RAD-10		
.3750	.5000	3.5	RAD-12		
.4375	.7500	4.5	RAD-14		
.5000	.7500	4.5	RAD-16		
.0312	.3750	2.5	RAD-1	RAD-24	837.00
.0625	.3750	2.5	RAD-2		
.0938	.3750	2.5	RAD-3		
.1250	.3750	2.5	RAD-4		
.1562	.3750	2.5	RAD-5		
.1875	.3750	2.5	RAD-6		
.2188	.3750	2.5	RAD-7		
.2500	.3750	2.5	RAD-8		
.2812	.5000	3.5	RAD-9		
.3125	.5000	3.5	RAD-10		
.3438	.5000	3.5	RAD-11		
.3750	.5000	3.5	RAD-12		
.4062	.7500	4.5	RAD-13		
.4375	.7500	4.5	RAD-14		
.4688	.7500	4.5	RAD-15		
.5000	.7500	4.5	RAD-16		

Sets

Sets

Brazed – Forming Tools – 90° Radius Concave – Left Hand



- Left hand tool designed for forming a convex radius
- Tangential 5° blend angles
- Solid carbide tipped with zinc coated steel shank for durability and corrosion resistance
- Available in industry standard fractional shank sizes
- Ground in the USA

Radius	Square Shank	Overall Length	Brazed	Set	
R $^{+.0005"}$ $_{-.0005"}$	A $^{+.0000"}$ $_{-.0050"}$	C	Tool #	Set #	Price
.0625	.3750	2.5	RAL-2	RAL-21	198.00
.1250	.3750	2.5	RAL-4		
.2500	.3750	2.5	RAL-8		
.3750	.5000	3.5	RAL-12		

Sets

Indexable Boring Bars – Facing – Coolant Through – Right Hand

Set Contents	Holder Nomenclature	Part Number	Set	
		Tool #	Set #	Price
3 STFCR Tool Holders 3/8", 1/2", and 5/8" Shank Diameters	A06J STFCR 2	20-1031	40-2100	266.00
	A08K STFCR 2	20-1033		
	A10M STFCR 2	20-1035		
3 Inserts	-	50-1300		
3 M2.5 x T-8 Torx Screws	-	16-1020		
1 Torx Key M2.5 x TK-8	-	16-1060		



Sets

Indexable Boring Bars – Boring – Coolant Through – Right Hand

Set Contents	Holder Nomenclature	Part Number	Set	
			Tool #	Set # Price
4 SCLCR Tool Holders 1/4", 5/16", 3/8", and 1/2" Shank Diameters	A04F SCLCR 2	20-0821	40-0100	316.30
	A05H SCLCR 2	20-0823		
	A06J SCLCR 2	20-0825		
	A08K SCLCR 2	20-0827		
4 Inserts	-	50-1100		
4 M2.5 x T-8 Torx Screws	-	16-1020		
1 Torx Key M2.5 x TK-8	-	16-1060		
3 Tool Holders 1/2", 5/8", 3/4" Shank Diameters	A08K SCLCR 3	20-0850	40-2500	376.85
	A10M SCLCR 3	20-0852		
	A12Q SCLCR 3	20-0854		
3 Inserts	-	50-1105		
3 M2.5 x T-8 Torx Screws	-	16-1020		
1 Torx Key M3.5 x TK-15	-	16-1070		



Sets

Sets

Indexable Boring Bars – Profiling – Coolant Through – Right Hand



Set Contents	Holder Nomenclature	Part Number	Set	
			Tool #	Set # Price
3 SDUCR Tool Holders 3/8", 1/2", and 5/8" Shank Diameters	A06J SDUCR 2	20-0931	40-2400	266.00
	A08K SDUCR 2	20-0933		
	A10M SDUCR 2	20-0935		
3 Inserts	-	50-1200		
3 M2.5 x T-8 Torx Screws	-	16-1020		
1 Torx Key M2.5 x TK-8	-	16-1060		



Sets

Indexable Boring Bars – Multi-Purpose Set 1

Sets



Set Contents	Holder Nomenclature	Part Number	Set	
			Tool #	Set #
6 Assorted Tool Holders 1/4" Square Shank	SCLCR 0404 D2	10-3231	40-7101	286.15
	SCLCL 0404 D2	10-3232		
	SCBCR 0404 D2	10-3151		
	SCKCR 0404 D2	10-3211		
	SCMCN 0404 D2	10-3311		
	SCSCR 0404 D2	10-3351		
1 Boring Bar 1/4" Shank Diameter	A04F SCLCR 2	21-0921		
7 Inserts	-	50-1100		
7 M2.5 x T-8 Torx Screws	-	16-1020		
1 Torx Key M2.5 x TK-8	-	16-1060		
6 Assorted Tool Holders 5/16" Square Shank	SCLCL 0404 D2	10-3233	40-7102	294.70
	SCLCL 0505 D2	10-3234		
	SCBCR 0505 D2	10-3153		
	SCKCR 0505 D2	10-3212		
	SCMCN 0505 D2	10-3312		
	SCSCR 0505 D2	10-3353		
1 Boring Bar 1/4" Shank Diameter	A05H SCLCR 2	21-0921		
7 Inserts	-	50-1100		
7 M2.5 x T-8 Torx Screws	-	16-1020		
1 Torx Key M2.5 x TK-8	-	16-1060		
6 Assorted Tool Holders 3/8" Square Shank	SCLCR 0606 E2	10-3235	40-7103	309.00
	SCLCL 0606 E2	10-3236		
	SCBCR 0606 E2	10-3155		
	SCKCR 0606 E2	10-3213		
	SCMCN 0606 E2	10-3313		
	SCSCR 0606 E2	10-3355		
1 Boring Bar 5/16" Shank Diameter	A06J SCLCR 2	21-0923		
7 Inserts	-	50-1100		
7 M2.5 x T-8 Torx Screws	-	16-1020		
1 Torx Key M2.5 x TK-8	-	16-1060		
6 Assorted Tool Holders 1/2" Square Shank	SCLCR 0808 F2	10-3237	40-7104	330.75
	SCLCL 0808 F2	10-3238		
	SCBCR 0808 F2	10-3157		
	SCKCR 0808 F2	10-3215		
	SCMCN 0808 F2	10-3314		
	SCSCR 0808 F2	10-3357		
1 Boring Bar 3/8" Shank Diameter	A08K SCLCR 2	20-0825		
7 Inserts	-	50-1100		
7 M2.5 x T-8 Torx Screws	-	16-1020		
1 Torx Key M2.5 x TK-8	-	16-1060		

Continued on next page

Sets

Indexable Boring Bars – Multi-Purpose Set 1 (cont.)

Continued from previous page



Set Contents	Holder Nomenclature	Part Number	Set	
			Tool #	Set #
6 Assorted Tool Holders 5/8" Square Shank	SCLCR 1010 H2	10-3241	40-7105	445.75
	SCLCL 1010 H2	10-3242		
	SCBCR 1010 H2	10-3159		
	SCKCR 1010 H2	10-3217		
	SCMCN 1010 H2	10-3315		
	SCSCR 1010 H2	10-3359		
1 Boring Bar 1/2" Shank Diameter	A10M SCLCR 2	20-0827		
7 Inserts	-	50-1100		
7 M2.5 x T-8 Torx Screws	-	16-1020		
1 Torx Key M2.5 x TK-8	-	16-1060		

Sets

Sets

Indexable Boring Bars – Multi-Purpose Set 2



Set Contents	Holder Nomenclature	Part Number	Set	
			Tool #	Set #
3 Tool Holders 3/4" Square Shank	SCLCR 1212 J3	10-3251	40-7150	479.65
	SCLCL 1212 J3	10-3252		
	SCSCR 1212 J3	10-3365		
1 Boring Bar 3/4" Shank Diameter	A12Q SCLCR 3	20-0854		
4 Inserts	-	50-1105		
4 M2.5 x T-8 Torx Screws	-	16-1020		
1 Torx Key M3.5 x TK-15	-	16-1070		

Sets

Indexable Boring Bars – Multi-Purpose Set 3

Sets

Set Contents	Holder Nomenclature	Part Number	Set	
			Tool #	Set # Price
3 Assorted Tool Holders 5/16" Square Shank	SDJCR 0505 H2 SDJCL 0505 H2 SDNCN 0505 H2	10-3641 10-3642 10-3761	40-7200	233.75
1 Boring Bar 5/16" Shank Diameter	A05H SDQCR 2	20-0901		
4 Inserts	-	50-1200		
4 M2.5 x T-8 Torx Screws	-	16-1020		
1 Torx Key M2.5 x TK-8	-	16-1060		
3 Assorted Tool Holders 3/8" Square Shank	SDJCR 0606 H2 SDJCL 0606 H2 SDNCN 0606 H2	10-3651 10-3652 10-3762		
1 Boring Bar 3/8" Shank Diameter	A06J SDUCR 2	21-1031		
4 Inserts	-	50-1200		
4 M2.5 x T-8 Torx Screws	-	16-1020		
1 Torx Key M2.5 x TK-8	-	16-1060		
3 Assorted Tool Holders 1/2" Square Shank	SDJCR 0808H2 SDJCL 0808H2 SDNCN 0808 H2	10-3653 10-3654 10-3763	40-7202	286.15
1 Boring Bar 1/2" Shank Diameter	A08K SDUCR 2	21-1033		
4 Inserts	-	50-1200		
4 M2.5 x T-8 Torx Screws	-	16-1020		
1 Torx Key M2.5 x TK-8	-	16-1060		
3 Assorted Tool Holders 5/8" Square Shank	SDJCR 1010 H2 SDJCL 1010 H2 SDNCN 1010 H2	10-3615 10-3616 10-3764		
1 Boring Bar 5/8" Shank Diameter	A10M SDUCR 2	21-1035		
4 Inserts	-	50-1200		
4 M2.5 x T-8 Torx Screws	-	16-1020		
1 Torx Key M2.5 x TK-8	-	16-1060		



Sets

Indexable – Milling – Tool Holders – Coolant Through

Set Contents	Holder Nomenclature	Part Number	Set	
			Tool #	Set # Price
3 Tool Holders 1/2" Shank Diameters	AAAP 1216 2	30-1216	60-3003	352.25
	AAAP 1616 2	30-1616		
	AAAP 1816 2	30-1816		
4 Inserts	-	50-2100		
4 M2.5 x T-8 Torx Screws	-	16-1020		
1 Torx Key M3.5 x TK-15	-	16-1070		



Sets

Sets

Combined Drill & Countersinks

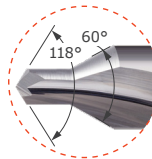
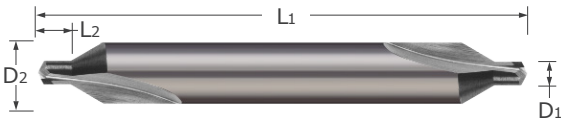

- Designed for predrilling 60° live center holes
- Can be utilized for countersinking and spot drilling
- Double-ended for quicker tool changes
- Solid carbide ■ CNC ground in the USA

Drill Diameter	Drill Length	Shank Diameter	Overall Length	Uncoated	Set	
				Tool #	Set #	Price
$D_1 \begin{smallmatrix} +.0030" \\ -.0000" \end{smallmatrix}$	L2	D2 (h6)	L1			
.0469	.047	.1250	1.500	DC-1	DC-0	369.00
.0781	.078	.1875	1.875	DC-2		
.1094	.109	.2500	2.000	DC-3		
.1250	.125	.3125	2.500	DC-4		
.1875	.188	.4375	2.750	DC-5		
.2188	.219	.5000	3.000	DC-6		

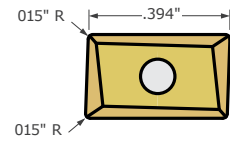
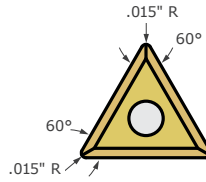
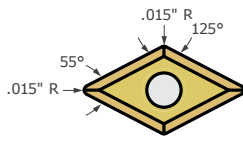
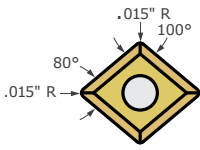

Indexable Inserts

Indexable Cutters – Inserts

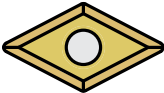

■ Solid carbide

Accessories

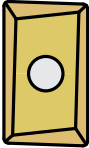
Insert Type	Insert*	
	Tool #	Price
	50-1100	11.15
	50-1105	13.45
	50-1200	11.75
	50-1300	10.05
	50-2100	12.25

*Must be ordered in quantities of 10.

CPG / SPG

Indexable Inserts

Indexable Cutters – Generic Inserts – Diamond Style

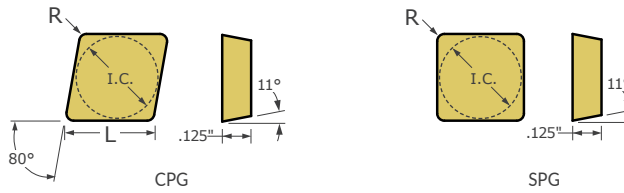

- 80° diamond insert with radius on corner
- For use in clamp locking style holder
- Solid carbide

Inscribed Circle	Length	Radius	Style	Diamond Style Insert	
				Tool #	Price
IC $\begin{matrix} +.001" \\ -.001" \end{matrix}$	L $\begin{matrix} +.001" \\ -.001" \end{matrix}$	R $\begin{matrix} +.003" \\ -.003" \end{matrix}$			
.464	.471	.015	CPG	CPG-4621	15.45
.464	.471	.031	CPG	CPG-4622	15.45
.500	.508	.015	CPG	CPG-421	13.85
.500	.508	.031	CPG	CPG-422	11.70
.375	-	.031	SPG	SPG-322	13.95
.500	-	.031	SPG	SPG-422	12.40

TPG / TP / TD

Indexable Inserts

Indexable Cutters – Generic Inserts – Triangle Style

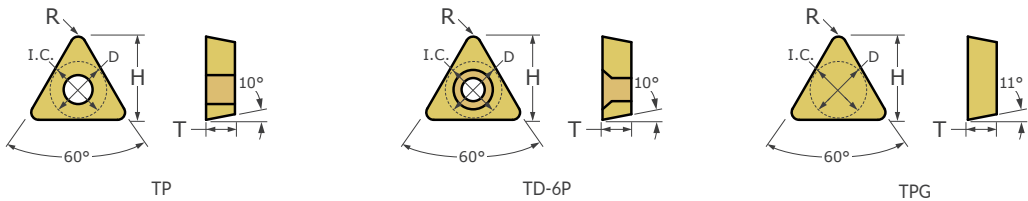

- 60° triangular insert with radius on corner
- For use with clamp locking style holder
- Solid carbide

Inscribed Circle	Thickness	Height	Radius	Hole Diameter	Set Screw UN	Style	Triangle Style Insert	
							Tool #	Price
IC $\begin{matrix} +.001" \\ -.001" \end{matrix}$	T $\begin{matrix} +.005" \\ -.005" \end{matrix}$	H	R $\begin{matrix} +.003" \\ -.003" \end{matrix}$	D $\begin{matrix} +.003" \\ -.003" \end{matrix}$				
.250	.094	.3438	.031	.137	4-40	TP	TP-42	13.20
.250	.094	.3600	.015	.137	4-40	TP	TP-41	9.30
.250	.125	.3440	.031			TPG	TPG-222	9.80
.375	.125	.5324	.031			TPG	TPG-322	11.70
.375	.125	.5324	.031	.163	6-32	TP	TP-62	15.35
.375	.125	.5324	.031	.125	4-40	TD	TD-6P-2	15.35
.375	.125	.5479	.015			TPG	TPG-321	11.00
.375	.125	.5479	.015	.163	6-32	TP	TP-61	15.35
.375	.125	.5480	.015	.125	4-40	TD	TD-6P-1	15.35
.500	.188	.7030	.047			TPG	TPG-433	17.85
.500	.188	.7199	.031			TPG	TPG-432	13.00



Accessories

Indexable Accessories

Accessories

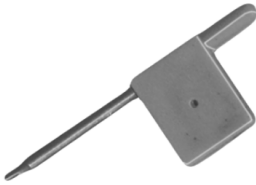
Accessory Type	Compatibility	Description	Accessory	
			Tool #	Price
	Inserts 50-1100 50-1200 50-1300 50-2100	Torx Screw M2.5 x T-8	16-1020	4.10
	Inserts 50-1105	Torx Screw M3.5 x T-15	16-1030	4.80
	Screw 16-1020	Torx Key M2.5 x TK-8	16-1060	3.80
	Screw 16-1030	Torx Key M3.5 x TK-15	16-1070	4.45

Micro100.com

Your Source for Fully Stocked Turning Tools & So Much More

Did you know that you can **place a Micro 100 order directly to your distributor from our website?** After creating your Mico100.com account, you're able to build and send "shopping carts" directly to your participating distributor to order.



Shopping Cart

Once logged in, create your own personalized Shopping Carts of Micro 100 tools you're most interested in, then send it directly to a participating distributor, or share it with a colleague or purchasing agent.



Expansive Stock Check

Check real-time availability of as many as 50 tools at once to simplify the order planning process and spend more time where it counts: at the spindle.



"Smart-Search" Feature

Simply and quickly search for a Micro 100 tool, then receive results for its product page, as well as for every technical resource relevant to that tool, presented in one click to save you valuable time and money.



Product Table Filtering

Find the perfect Micro 100 tool for your job quickly and easily by using new filtering functionality on each product table, sorting through an expansive and always growing product offering.

Technical Resources

Now offering downloadable Sim Files in .STEP format for every one of our catalog items, and user-friendly Speeds & Feeds charts for all quick change and standard shank turning tools.



Speeds & Feeds Online



SIM Files Online

See more resources at
[Micro100.com/resources](https://www.micro100.com/resources)

Coatings Chart

Coating/ Substrate:	TiN Titanium Nitride -G	AlTiN Aluminum Titanium Nitride -X	nACRo® Aluminum Chromium Nitride Silicone -K	ZrN Zirconium Nitride -S
Application/ Benefits:	<ul style="list-style-type: none"> General purpose coating with proven performance and increasing tool productivity with higher feeds and speeds in machining of ferrous materials and in applications that are not generating excessive/ extreme heat 	<ul style="list-style-type: none"> Maintains high surface hardness at elevated temperatures, promotes tool life and allows for faster feeds and speeds Higher breakdown temperatures High Performance and versatile coating Excellent for dry-machining 	<ul style="list-style-type: none"> Extremely heat and scratch resistant coating that provides exceptional performance for those "tough and difficult" materials where temperatures increase dramatically during the machining application 	<ul style="list-style-type: none"> Better tool performance over uncoated carbide in numerous non-ferrous materials Characteristics include a high hardness with lubricity and abrasion resistance Generally, an alternative to diamond coatings
Materials:	General purpose, ferrous and non-ferrous materials	Alloy steels, stainless steels, tool steels, titanium, inconel, nickel and other aerospace materials	Aluminum Alloy Steels, Carbon Steels, Stainless Steels, Hardened Steels, Nickel Alloys, Cast Irons, Titanium and other High Temperature Alloys	Abrasive non-ferrous alloys such as Brass, Bronze, Copper and Abrasive Aluminum Alloys
Color:	Gold	Dark Gray / Black	Black / Gray	Light Gold / Champagne
Structure:	Mono-layer	Multi-layer	Nano-composite	Mono-layer
Hardness (HV 0.05):	2170 (21 GPa)	3569 (35 GPa)	4079(40 GPa)	2460 (24 GPa)
Coefficient of Friction:	.50	.60	0.45	.50
Coating Thickness (microns):	2 - 5	2 - 5	1 - 7	2 - 5
Max. Working Temp:	1000° F	1400° F	2012° F	1100° F

PLEASE NOTE: Information and test results were compiled from multiple sources and testing methods. Data presented is intended to be a general application guideline for comparing various coatings.



"THE ORIGINAL"
SPEEDY SHARP
World's Fastest Sharpener®

Utilizing the same strong, durable carbide as Micro 100 cutting tools, the Speedy Sharp sharpens everything from pocket knives to lawn mower blades with ease.

**Quickly &
Effectively
Sharpens**

- Knives
- Scissors
- Axes
- Hunting Knives
- Gardening Tools
- Lawn Mower Blades
- Razor Blades
- Chisels
- Planer Blades
- Router Bits
- Fish Hooks

TOOL # KS-1

Add a Speedy Sharp (KS-1) to your tooling order today for only \$14.80

Learn more at speedysharp.com



All Tools Stocked ▪ Same Day Shipping

Harvey Performance Company, LLC
428 Newburyport Turnpike
Rowley, MA 01969

800-421-8065 ▪ micro100sales@harveyperformance.com

Presort STD
US Postage
PAID
Harvey Tool

Call us at **800-421-8065** or visit us at **micro100.com** to find your local distributor!

Make More Than Ever Before

With more than 1,000 new products added to our expansive offering, your potential to Make More With Micro 100 has never been greater.

Enjoy our refreshed layout and enhanced navigation, featuring two new catalog sections: **Tool Holders & Systems** (featuring our new PSC Holders and new Rotational Holder offering) and **Holemaking & Threading** (featuring our new line of Miniature Drills).

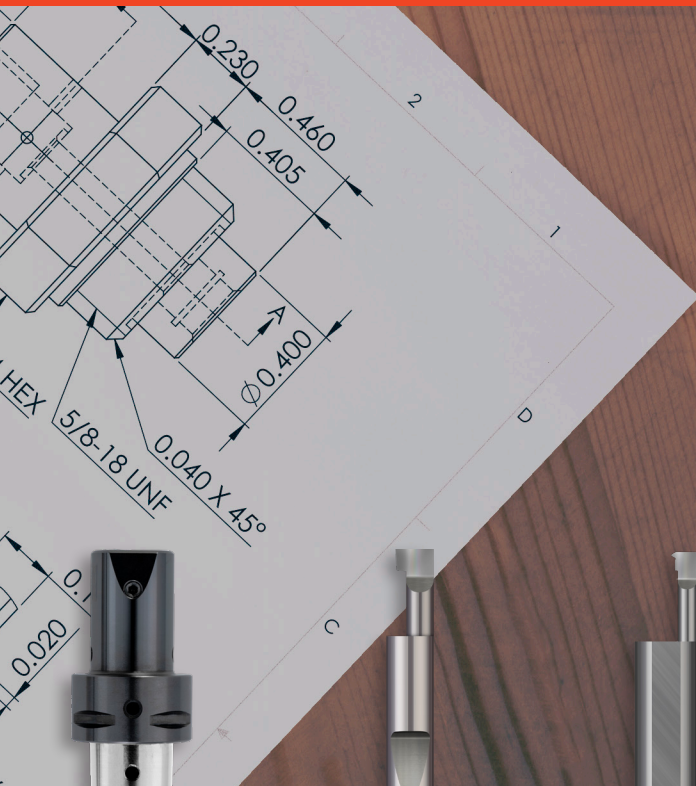

pg 13

**Tool Holders
& Systems**



pg 46

Turning Tools



pg 204

**Holemaking
& Threading**



pg 216

Milling Tools



pg 300

**Blanks, Sets
& Accessories**



Find Your Local
Authorized Distributor



Build and Send Shopping
Carts to a Distributor



Product Table Filtering for
Simplified Tool Selection



Check Real-time
Stock of All Products

HARVEY PERFORMANCE
COMPANY

HARVEY TOOL *Helical* **MICRO 100** **TITAN USA** **COREHOG**



Find Your Local Distributor
on Micro100.com



Proud Partner of One Tree Planted
in Environmental Conservation Efforts
Visit harveyperformance.com/trees