

L2

L1

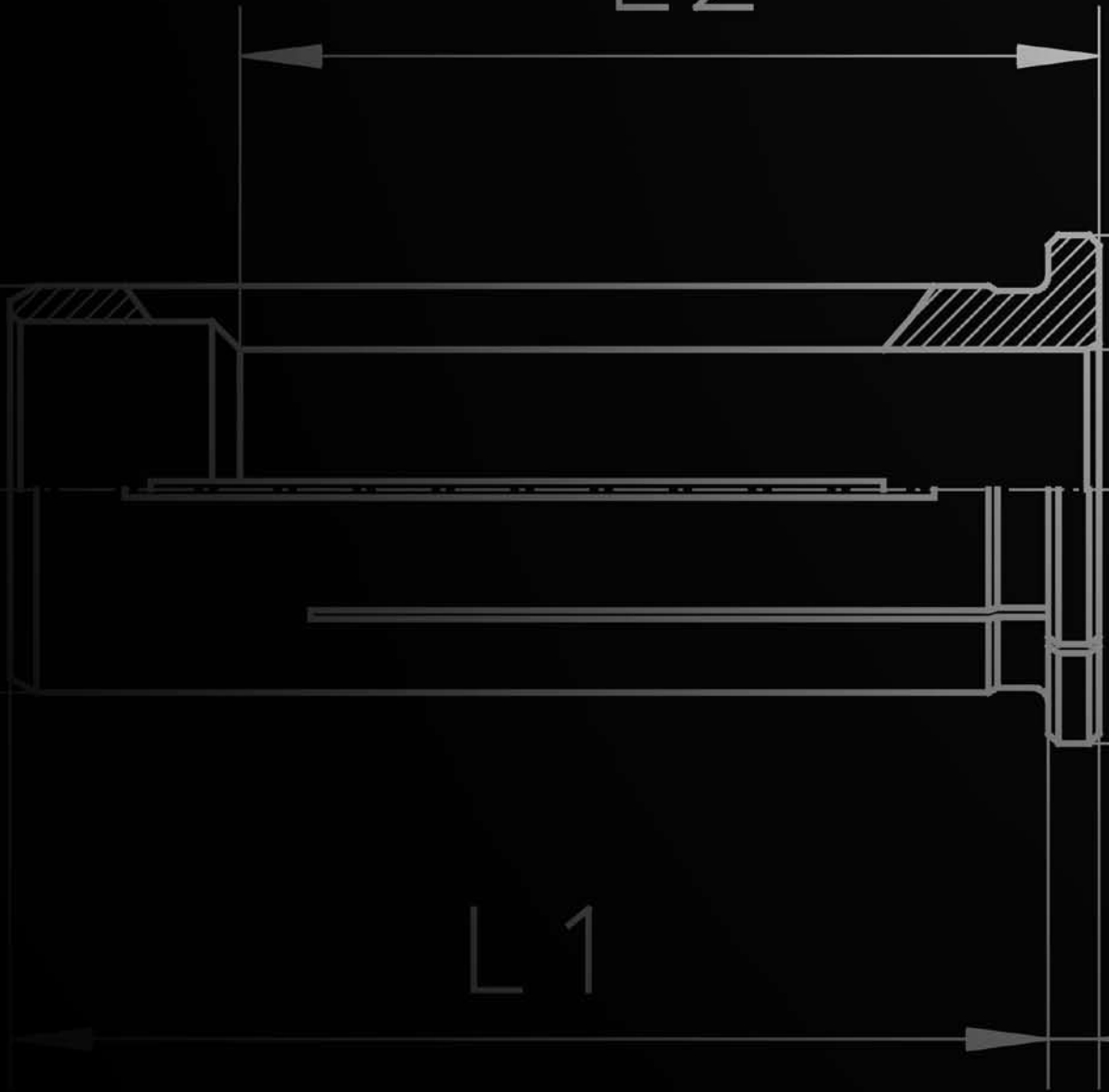

**ER**SYSTEM

- 14.01 Collet Cavity Dimension**
- 14.02 Dimensions of ER Collets**
- 14.03 Clamping Nuts Tightening Torque**
- 14.05 ER-GB Tapping Collets**
- 14.06 ET1 Tapping Collets**
- 14.06 ER-MB Microbore Collets**

**powRgrip**SYSTEM

- 14.07 Presetting Range Collets**
- 14.08 Presetting Range Tapping Collets**

**Other Information**

- 14.09 Hydraulic Sleeves**
- 14.11 Tap Dimensions**
- 14.12 Legal Notices**

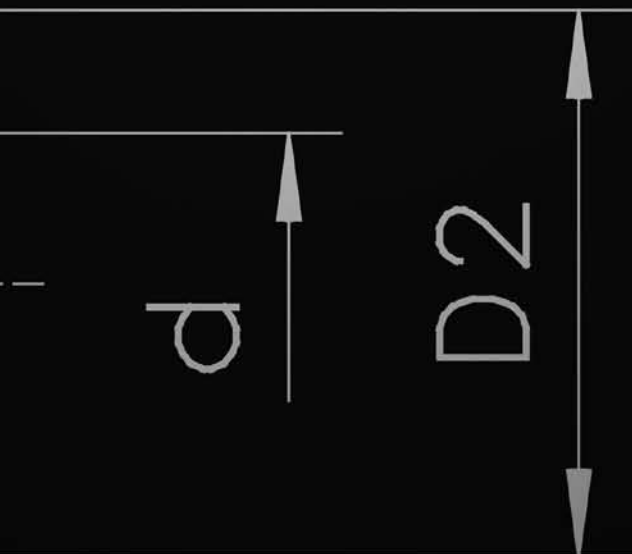

## Collet Cavity Dimensions

### Dimensions for ER Collet Cavities in Machine Spindles

Size	Clamping Range	A [mm]	B [mm]	C [mm]	E [mm]	F [mm]	Drawing
<b>Standard Nut Threads</b>							
ER 11	0.5 – 07.00	7.5	11	M14 x 0.75	17.0	10.0	1
ER 16	0.5 – 10.00	10.5	16	M22 x 1.50	22.0	13.0	1
ER 20	0.5 – 13.00	13.5	20	M25 x 1.50	26.5	13.5	1
ER 25	0.5 – 16.00	18.0	25	M32 x 1.50	29.0	14.0	1
ER 32	1.0 – 20.00	23.5	32	M40 x 1.50	34.0	16.0	1
ER 40	2.0 – 30.00	30.5	40	M50 x 1.50	38.0	17.0	1
ER 50	4.0 – 34.00	38.0	50	M64 x 2.00	48.0	24.0	1
<b>Mini-Nut Threads</b>							
ER 8	0.5 – 05.00	5.2	8	M10 x 0.75	13.0	8.0	1
ER 11	0.5 – 07.00	7.5	11	M13 x 0.75	17.0	8.5	1
ER 16	0.5 – 10.00	10.5	16	M19 x 1.00	22.0	13.0	1
ER 20	0.5 – 13.00	13.5	20	M24 x 1.00	26.5	13.5	1
ER 25	0.5 – 16.00	18.0	25	M30 x 1.00	29.0	14.0	1
<b>Extremely Threaded Nut Threads</b>							
ER 11	0.5 – 07.00	7.5	11	M18 x 1.00	23.0	7.0	2
ER 16	0.5 – 10.00	10.5	16	M24 x 1.00	32.0	10.0	2
ER 20	0.5 – 13.00	13.5	20	M28 x 1.50	37.5	11.0	2
ER 25	0.5 – 16.00	18.0	25	M32 x 1.50	41.0	12.0	2
ER 32	1.0 – 20.00	23.5	32	M40 x 1.50	48.0	14.0	2
ER 40	2.0 – 30.00	30.5	40	M50 x 1.50	54.0	16.0	2

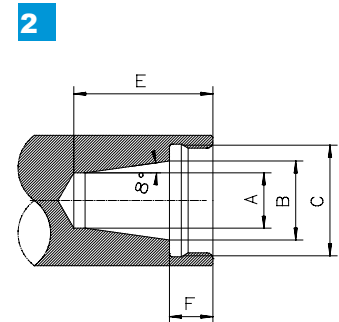
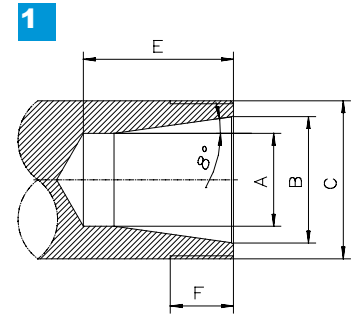

### Dimensions of ER Collets

Size	d [mm]	D1 [mm]	D2 [mm]	D3 [mm]	D4 [mm]	L [mm]	L1 [mm]	L2 [mm]	L3 [mm]	L4 [mm]	Drawing
ER 8	1.0 – 2.50	8.5	8.0	6.5	4.0	13.6	2.98	1.2	1.5	6.0	1
ER 8	3.0 – 5.00	8.5	8.0	6.5	–	13.6	2.98	1.2	1.5	–	2
ER 11	1.0 – 2.50	11.5	11.0	9.5	5.0	18.0	3.80	2.0	2.5	9.0	3
ER 11	3.0 – 7.00	11.5	11.0	9.5	–	18.0	3.80	2.0	2.5	–	4
ER 16	1.0 – 1.59	17.0	16.0	13.8	7.5	27.5	6.26	2.7	4.0	13.0	3
ER 16	2.0 – 4.76	17.0	16.0	13.8	7.5	27.5	6.26	2.7	4.0	10.0	3
ER 16	5.0 – 10.00	17.0	16.0	13.8	–	27.5	6.26	2.7	4.0	–	4
ER 20	1.0 – 1.59	21.0	20.0	17.4	9.0	31.5	6.36	2.8	4.8	16.0	3
ER 20	2.0 – 6.50	21.0	20.0	17.4	9.0	31.5	6.36	2.8	4.8	13.0	3
ER 20	7.0 – 13.00	21.0	20.0	17.4	–	31.5	6.36	2.8	4.8	–	4
ER 25	1.0 – 1.59	26.0	25.0	22.0	12.0	34.0	6.66	3.1	5.0	18.0	3
ER 25	2.0 – 7.50	26.0	25.0	22.0	12.0	34.0	6.66	3.1	5.0	15.0	3
ER 25	8.0 – 16.00	26.0	25.0	22.0	–	34.0	6.66	3.1	5.0	–	4
ER 32	2.0 – 4.76	33.0	32.0	29.2	15.0	40.0	7.16	3.6	5.5	20.0	3
ER 32	5.0 – 7.50	33.0	32.0	29.2	15.0	40.0	7.16	3.6	5.5	15.0	3
ER 32	8.0 – 20.00	33.0	32.0	29.2	–	40.0	7.16	3.6	5.5	–	4
ER 40	3.0 – 4.76	41.0	40.0	36.2	20.0	46.0	7.66	4.1	7.0	24.0	3
ER 40	5.0 – 8.50	41.0	40.0	36.2	20.0	46.0	7.66	4.1	7.0	18.0	3
ER 40	9.0 – 30.00	41.0	40.0	36.2	–	46.0	7.66	4.1	7.0	–	4
ER 50	6.0 – 10.00	52.0	50.0	46.0	20.0	60.0	12.60	5.5	8.5	32.0	3
ER 50	12.0 – 34.00	52.0	50.0	46.0	–	60.0	12.60	5.5	8.5	–	4

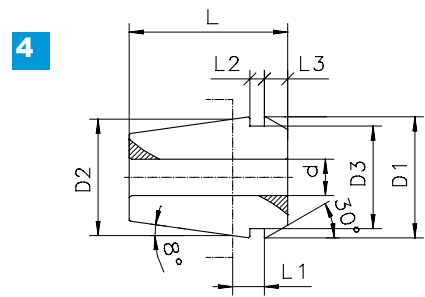
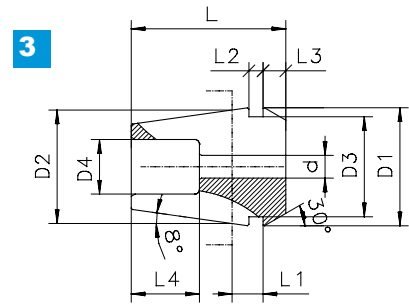
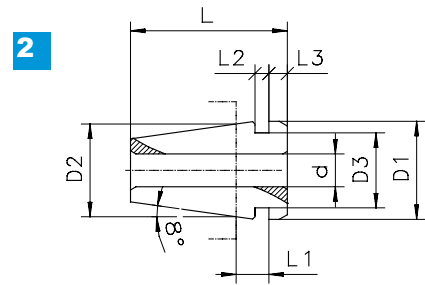
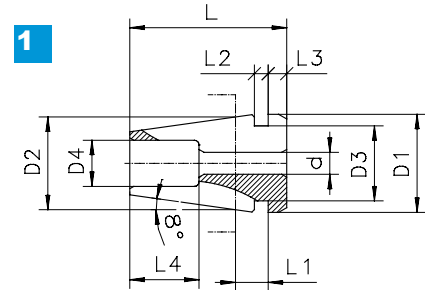

## Clamping Nuts Tightening Torque

### Recommended Tightening Torque

Collet Size	Ø mm	Ø inch	Nut Torque (ft-lbs)						Recommended Torque Wrench
			Hi-Q & Hi-QC		Hi-QB & Hi-QBC		AX & AXC		
			ER	ER-GB	ER	ER-GB	ER	ER-GB	
ER 11 MB	0.2 – 0.9	0.0078 – 0.035	6				6		Small
ER 11	1.0 – 2.5	0.0390 – 0.098	6	6			6	6	
	3.0 – 7.0	0.1180 – 0.256	20	12			20	15	
ER 16 MB	0.2 – 0.9	0.0078 – 0.035	6				6		Small
ER 16	1	0.039	6		5		6		
	1.5 – 3.5	0.059 – 0.138	15		12		15		
	4.0 – 4.5	0.157 – 0.177	30	30	25	25	30	30	
	5.0 – 10.0	0.197 – 0.394	40	32	40	32	30	30	
ER 20	1	0.039	12		10		12		Small
	1.5 – 6.5	0.059 – 0.256	25	25	20	20	25	25	Medium
	7.0 – 13.0	0.276 – 0.512	60	26	60	60	40	26	
ER 25	1.0 – 3.5	0.039 – 0.138	20		15		20		Medium
	4.0 – 4.5	0.157 – 0.177	40	40	35	35	40	40	
	5.0 – 7.5	0.196 – 0.295	60	60	55	55	60	60	
	8.0 – 16.0	0.315 – 0.630	80	80	80	60	60	60	
ER 32	2.0 – 2.5	0.078 – 0.098	20		15		20		Small
	3.0 – 7.5	0.118 – 0.291	100	100	95	80	80	80	Large
	8.0 – 20.0	0.315 – 0.787	100	110	100	85	80	80	
ER 40	3.0 – 8.5	0.118 – 0.335	130	130	130	130	95	95	Large
	9.0 – 26.0	0.354 – 1.023	130	130	130	140	95	95	
ER 50	6.0 – 34.0	0.236 – 1.338	180	220	180	220			Large



The maximum torque must not be more than 25% above the recommended tightening torque. Higher tightening torque may result in the damage of the toolholder.



Higher clamping force of the clamping nut means higher stress on the toolholder. We recommend the use of REGO-FIX® torque wrench. REGO-FIX® will not be responsible for damage to toolholders or spindles of other manufacturers.

Torque wrenches and matching products see page 13.03/13.04

## Clamping Nuts Tightening Torque

### Recommended Tightening Torque

Collet Size	Ø mm	Ø inch	Nut Torque (ft-lbs)				Recommended Torque Wrench
			Hi-QM & Hi-QMC		MS		
			ER	ER-GB	ER	ER-GB	
ER 8 MB	0.2 – 0.9	0.0078 – 0.035	4		4		Micro
ER 8	1.0 – 1.5	0.039 – 0.060	4		4		
	2.0 – 2.5	0.079 – 0.197	4		4		
	3.0 – 5.0	0.118 – 0.197	4		4		
ER 11 MB	0.2 – 0.9	0.0078 – 0.035	6		6		Small
ER 11	1.0 – 2.5	0.039 – 0.098	6	6	7		
	3.0 – 7.0	0.118 – 0.256	12	10	7		
ER 16 MB	0.2 – 0.9	0.0078 – 0.035	9		9		Small
ER 16	1	0.039	9		9		
	1.5 – 3.5	0.059 – 0.138	18		15		
	4.0 – 4.5	0.157 – 0.177	18	18	15		
	5.0 – 10.0	0.197 – 0.394	18	18	15		
ER 20	1	0.039	12		9		
	1.5 – 6.5	0.059 – 0.256	21	21	14		
	7.0 – 13.0	0.276 – 0.512	21	21	14		
ER 25	1.0 – 3.5	0.039 – 0.138	18				Small
	4.0 – 7.5	0.157 – 0.295	24	24			
	5.0 – 16.0	0.196 – 0.630	24	24			

**!** The maximum torque must not be more than 25% above the recommended tightening torque. Higher clamping force of the clamping nut at the same time means higher stress on the toolholder.

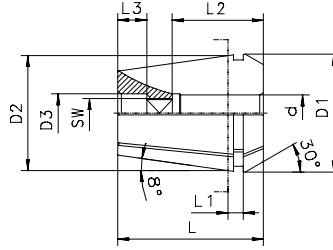

### Rigid Tap Collets

d [mm]	SW [mm]	L2 [mm]	D3 [mm]	ER 11-GB L = 18.0 L1 = 2.0 D1 = 11.3 D2 = 11.0 L3 [mm]	ER 16-GB L = 27.5 L1 = 2.7 D1 = 16.8 D2 = 16.0 L3 [mm]	ER 20-GB L = 31.5 L1 = 2.8 D1 = 20.8 D2 = 20.0 L3 [mm]	ER 25-GB L = 34.0 L1 = 3.1 D1 = 25.8 D2 = 25.0 L3 [mm]	ER 32-GB L = 40.0 L1 = 3.6 D1 = 32.8 D2 = 32.0 L3 [mm]	ER 40-GB L = 46.0 L1 = 4.1 D1 = 40.8 D2 = 40.0 L3 [mm]	ER 50-GB L = 60.0 L1 = 8.75 D1 = 51.8 D2 = 51.0 L3 [mm]
2.8	2.1	12	–	0	–	–	–	–	–	–
3.5	2.7	14	–	0	–	–	–	–	–	–
4	3	14	–	0	–	–	–	–	–	–
4	3.15/3.2	ER 11=14 ER 16-32=18	4.5	0	5.5	9.5	12	18	–	–
4.5	3.4	ER 11=14 ER 16-32=18	ER 11= N/A ER 16-32 = 5.0	0	5.5	9.5	12	18	–	–
5	4	ER 11=14 ER 16-32=18	5.5	0	5.5	9.5	12	18	–	–
5.5	4.3	18	6	–	5.5	9.5	12	18	–	–
5.5	4.5	18	6	–	5.5	9.5	12	18	–	–
6	4.5	18	6.5	–	4.5	8.5	11	18	23	–
6	4.9	ER 11=14 ER 16-40=18	ER 11= N/A ER 16-40 = 6.5	0	4.5	8.5	11	17	23	–
6.2	5	18	6.7	–	4.5	8.5	11	17	23	–
6.3	5	18	6.8	–	4.5	8.5	11	17	23	–
7	5.5	18	7.5	–	3.5	7.5	10	16	22	–
7.1	5.6	18	7.6	–	3.5	7.5	10	16	22	–
8	6.2/6.3	22	8.6	–	–	2.5	5	11	17	–
8.5	6.5	22	9	–	–	2.5	5	11	17	–
9	7.0/7.1	22	9.6	–	–	2.5	4	10	16	–
10	8	25	10.5	–	–	–	–	7	13	–
10.5	8	25	11	–	–	–	–	7	13	–
11	9	25	11.5	–	–	–	–	6	12	–
11.2	9	25	11.7	–	–	–	–	6	12	–
12	9	25	12.5	–	–	–	–	6	12	–
12.5	10	25	13	–	–	–	–	5	11	–
14	11.0/11.2	25	14.7	–	–	–	–	4	10	–
15	12	25	15.5	–	–	–	–	4	10	–
16	12	25	16.5	–	–	–	–	3	9	–
17	13	25	17.5	–	–	–	–	3	9	–
18	14.5	25	18.5	–	–	–	–	3	8	–
20	16	28	20.5	–	–	–	–	3	4	–
22	18	ER 40 = 28 ER 50 = 41	ER 40 = 22.5 ER 50 = 25.5	–	–	–	–	–	4	–
25	20	41	28.5	–	–	–	–	–	–	–
28	22	41	31.5	–	–	–	–	–	–	–
32	24	41	34.5	–	–	–	–	–	–	–

## PCM Axial Compensating Tapping Collets

Type	Range	d [mm]	D1 [mm]	D2 [mm]	L [mm]	L1 [mm]	L2 [mm]	L3 [mm]	L4 [mm]	M [mm]
ET1-12	M 0.5 – M 4	3.55	7	11.5	18	16.5	2.5	5	5.5	2 x M 2.5
ET1-16	M 0.7 – M 6	6.3	11	17	22	20	2.8	7	7	2 x M 4 4 x M 4
ET1-20	M 1 – M 8 (M 10)	7.1	14	21	24	23	2.8	8	7	2 x M 4 4 x M 4 4 x M 5
ET1-25	M 1 – M 10 (M 12)	10	19	26	26	24	3	10	8	2 x M 5 4 x M 5 4 x M 6
ET1-32	M 4 – M 12 (M 16)	12.5	23	33	33	32	3	11	10	2 x M 5 4 x M 5 4 x M 6 4 x M 8
ET1-40	M 6 ... M 16 (M 20)	17	28	41	42	42	3	12	13	4 x M 6 4 x M 6

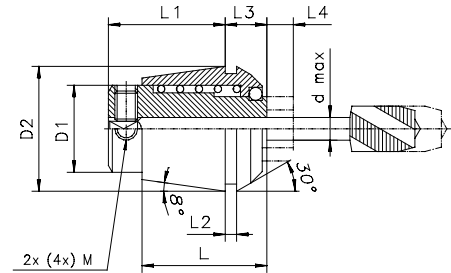

ER | MB  
DIN 6499

## Microbore Collets

Size	d [mm]	D1 [mm]	D2 [mm]	D3 [mm]	D4 [mm]	L [mm]	L1 [mm]	L2 [mm]	L3 [mm]	L4 [mm]	Drawing
ER 8-MB	0.2 – 0.9	8.5	8.0	6.5	4.0	13.5	1.2	1.2	1.5	6.0	1
ER 11-MB	0.2 – 0.9	11.5	11.0	9.5	5.0	18.0	2.0	2.0	2.5	9.0	2
ER 16-MB	0.2 – 0.9	17.0	16.0	13.8	7.5	27.5	6.3	2.7	4.0	13.0	2

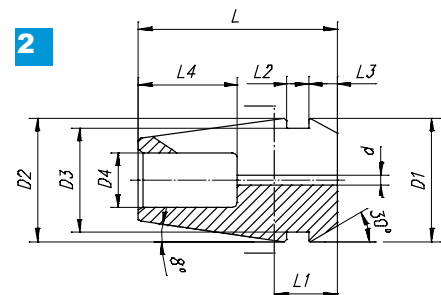
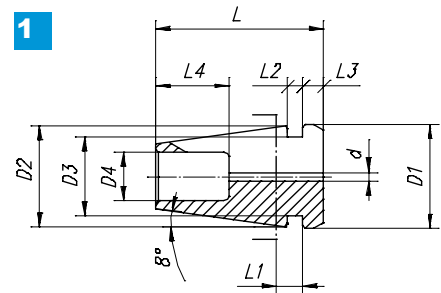

The ER-MB collets are only available in the above mentioned ER series. They do not have a clamping range! Only nominal diameters with h7 tolerance shanks can be clamped!



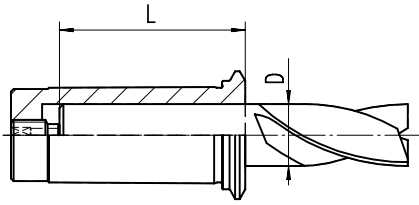

## Presetting Range

### Presetting Range of powRgrip® Collets

D [mm]	PG 10			PG 15			PG 25			PG 32		
	L* [mm]	L min. [mm]	L max. [mm]	L* [mm]	L min. [mm]	L max. [mm]	L* [mm]	L min. [mm]	L max. [mm]	L* [mm]	L min. [mm]	L max. [mm]
0.20/1.00	–	19.0	22.0	–	–	–	–	–	–	–	–	–
1.50	–	15.0	18.0	–	–	–	–	–	–	–	–	–
2.00/2.50	28.0	24.0	30.0	–	–	–	–	–	–	–	–	–
3.00/4.00/5.00	28.0	24.0	30.0	28.0	25.0	32.0	28.0	25.0	32.0	–	–	–
6.00	33.5	30.0	35.5	36.0	33.0	40.0	36.0	33.0	40.0	36.0	33.6	42.5
7.00/8.00/9.00	–	–	–	36.0	33.0	40.0	36.0	33.0	40.0	36.0	33.6	42.5
10.00	–	–	–	40.0	37.0	40.5	40.0	37.0	44.0	40.0	37.6	46.5
11.00	–	–	–	–	–	–	40.0	37.0	44.0	40.0	37.6	46.5
12.00/14.00	–	–	–	–	–	–	45.0	42.0	49.0	45.0	42.6	51.5
16.00/18.00	–	–	–	–	–	–	48.0	45.0	50.0	48.0	45.6	54.5
20.00	–	–	–	–	–	–	50.0	47.0	50.0	50.0	47.6	56.5
22.00*	–	–	–	–	–	–	–	–	–	50.0	47.6	56.5
25.00	–	–	–	–	–	–	–	–	–	56.0	53.6	62.5

L\* : Please insure proper shank length of cutter



Never clamp a powRgrip® collet without a tool.  
Collet will be damaged!

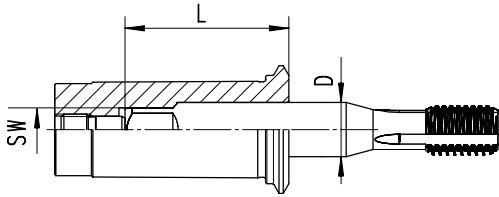

## Presetting Range TAP

### Presetting Range of powRgrip® Tapping Collets

D [mm]	SW [mm]	PG 15		PG 25	
		L* [mm]	L min. [mm]	L* [mm]	L min. [mm]
3.5	2.7	29	27	–	–
4.5	3.4	29	27	–	–
6	4.9	31	29	–	–
7	5.5	31	29	–	–
8	6.2	36	33.5	36	33.5
9	7	37	34.5	37	34.5
10	8	38	35.5	41	38.5
11	9	–	–	42	39.5
12	9	–	–	42	39.5
14	11	–	–	44	41.5
16	12	–	–	45	42.5

L\* : Please insure proper shank length of tap



Never clamp a powRgrip® tap collet without a tool. Collet will be damaged!

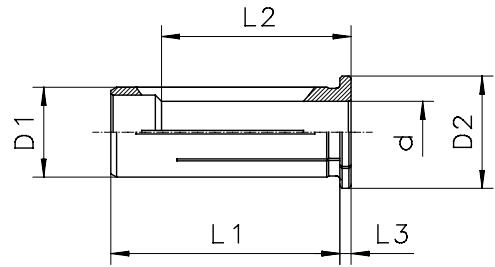

## HS 12 | HS 20

### Hydraulic Sleeves HS 12

Type	d [mm]	d [Inch]	D1 [mm]	D2 [mm]	L1 [mm]	L2 [mm]	L3 [mm]
HS 12 / Ø 3.00	3.000		12	16	40	29	4
HS 12 / Ø 1/8"	3.175	1/8"	12	16	40	29	4
HS 12 / Ø 4.00	4.000		12	16	40	29	4
HS 12 / Ø 3/16"	4.763	3/16"	12	16	40	29	4
HS 12 / Ø 5.00	5.000		12	16	40	29	4
HS 12 / Ø 6.00	6.000		12	16	40	36	4
HS 12 / Ø 1/4"	6.350	1/4"	12	16	40	36	4
HS 12 / Ø 7.00	7.000		12	16	40	37	4
HS 12 / Ø 5/16"	7.938	5/16"	12	16	40	37	4
HS 12 / Ø 8.00	8.000		12	16	40	37	4
HS 12 / Ø 9.00	9.000		12	16	40	37	4
HS 12 / Ø 3/8"	9.525	3/8"	12	16	40	40	4
HS 12 / Ø 10.00	10.000		12	16	40	40	4

### Hydraulic Sleeves HS 20

Type	d [mm]	d [Inch]	D1 [mm]	D2 [mm]	L1 [mm]	L2 [mm]	L3 [mm]
HS 20 / Ø 3.00	3.000		20	25	50	28	4
HS 20 / Ø 1/8"	3.175	1/8"	20	25	50	28	4
HS 20 / Ø 4.00	4.000		20	25	50	28	4
HS 20 / Ø 3/16"	4.763	3/16"	20	25	50	28	4
HS 20 / Ø 5.00	5.000		20	25	50	28	4
HS 20 / Ø 6.00	6.000		20	25	50	36	4
HS 20 / Ø 1/4"	6.350	1/4"	20	25	50	36	4
HS 20 / Ø 7.00	7.000		20	25	50	38	4
HS 20 / Ø 5/16"	7.938	5/16"	20	25	50	37	4
HS 20 / Ø 8.00	8.000		20	25	50	37	4
HS 20 / Ø 9.00	9.000		20	25	50	38	4
HS 20 / Ø 3/8"	9.525	3/8"	20	25	50	38	4
HS 20 / Ø 10.00	10.000		20	25	50	40	4
HS 20 / Ø 11.00	11.000		20	25	50	40	4
HS 20 / Ø 12.00	12.000		20	25	50	45	4
HS 20 / Ø 1/2"	12.700	1/2"	20	25	50	45	4
HS 20 / Ø 13.00	13.000		20	25	50	45	4
HS 20 / Ø 14.00	14.000		20	25	50	45	4
HS 20 / Ø 15.00	15.000		20	25	50	45	4
HS 20 / Ø 5/8"	15.875	5/8"	20	25	50	48	4
HS 20 / Ø 16.00	16.000		20	25	50	48	4



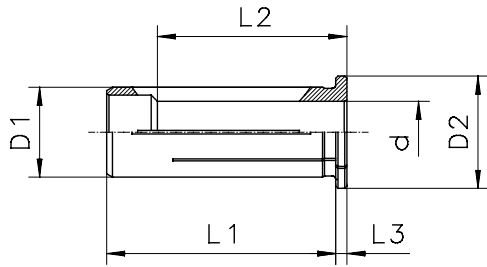

## HS25 | HS32

### Hydraulic Sleeves HS 25

Type	d [mm]	d [Inch]	D1 [mm]	D2 [mm]	L1 [mm]	L2 [mm]	L3 [mm]
HS 25 / Ø 3.00	3.000		25	30	56	29	4
HS 25 / Ø 1/8"	3.175	1/8"	25	30	56	29	4
HS 25 / Ø 4.00	4.000		25	30	56	29	4
HS 25 / Ø 3/16"	4.763	3/16"	25	30	56	29	4
HS 25 / Ø 5.00	5.000		25	30	56	29	4
HS 25 / Ø 6.00	6.000		25	30	56	37	4
HS 25 / Ø 1/4"	6.350	1/4"	25	30	56	37	4
HS 25 / Ø 7.00	7.000		25	30	56	37	4
HS 25 / Ø 5/16"	7.938	5/16"	25	30	56	37	4
HS 25 / Ø 8.00	8.000		25	30	56	37	4
HS 25 / Ø 9.00	9.000		25	30	56	38	4
HS 25 / Ø 3/8"	9.525	3/8"	25	30	56	38	4
HS 25 / Ø 10.00	10.000		25	30	56	40	4
HS 25 / Ø 7/16"	11.112	7/16"	25	30	56	40	4
HS 25 / Ø 12.00	12.000		25	30	56	46	4
HS 25 / Ø 1/2"	12.700	1/2"	25	30	56	46	4
HS 25 / Ø 14.00	14.000		25	30	56	47	4
HS 25 / Ø 9/16"	14.288	9/16"	25	30	56	47	4
HS 25 / Ø 5/8"	15.875	5/8"	25	30	56	48	4
HS 25 / Ø 16.00	16.000		25	30	56	48	4
HS 25 / Ø 11/16"	17.461	11/16"	25	30	56	48	4
HS 25 / Ø 18.00	18.000		25	30	56	48	4
HS 25 / Ø 3/4"	19.050	3/4"	25	30	56	48	4
HS 25 / Ø 20.00	20.000		25	30	56	50	4
HS 25 / Ø 13/16"	20.638	13/16"	25	30	56	50	4

### Hydraulic Sleeves HS 32

Type	d [mm]	d [Inch]	D1 [mm]	D2 [mm]	L1 [mm]	L2 [mm]	L3 [mm]
HS 32 / Ø 3/16"	4.763	3/16"	32	36	60	29	4
HS 32 / Ø 5.00	5.000		32	36	60	29	4
HS 32 / Ø 6.00	6.000		32	36	60	36	4
HS 32 / Ø 1/4"	6.350	1/4"	32	36	60	36	4
HS 32 / Ø 7.00	7.000		32	36	60	37	4
HS 32 / Ø 5/16"	7.938	5/16"	32	36	60	36	4
HS 32 / Ø 8.00	8.000		32	36	60	36	4
HS 32 / Ø 9.00	9.000		32	36	60	37	4
HS 32 / Ø 3/8"	9.525	3/8"	32	36	60	37	4
HS 32 / Ø 10.00	10.000		32	36	60	40	4
HS 32 / Ø 11.00	11.000		32	36	60	40	4
HS 32 / Ø 7/16"	11.112	7/16"	32	36	60	45	4
HS 32 / Ø 12.00	12.000		32	36	60	45	4
HS 32 / Ø 1/2"	12.700	1/2"	32	36	60	45	4
HS 32 / Ø 13.00	13.000		32	36	60	45	4
HS 32 / Ø 14.00	14.000		32	36	60	46	4
HS 32 / Ø 9/16"	14.288	9/16"	32	36	60	46	4
HS 32 / Ø 15.00	15.000		32	36	60	46	4
HS 32 / Ø 5/8"	15.875	5/8"	32	36	60	46	4
HS 32 / Ø 16.00	16.000		32	36	60	48	4
HS 32 / Ø 17.00	17.000		32	36	60	48	4
HS 32 / Ø 11/16"	17.461	11/16"	32	36	60	48	4
HS 32 / Ø 18.00	18.000		32	36	60	49	4
HS 32 / Ø 19.00	19.000		32	36	60	49	4
HS 32 / Ø 3/4"	19.050	3/4"	32	36	60	50	4
HS 32 / Ø 20.00	20.000		32	36	60	50	4
HS 32 / Ø 13/16"	20.638	13/16"	32	36	60	50	4
HS 32 / Ø 22.00	22.000		32	36	60	50	4
HS 32 / Ø 7/8"	22.225	7/8"	32	36	60	50	4
HS 32 / Ø 15/16"	23.813	15/16"	32	36	60	52	4
HS 32 / Ø 25.00	25.000		32	36	60	56	4
HS 32 / Ø 1"	25.400	1"	32	36	60	56	4

**!** Never clamp a reduction sleeve without a tool.  
Sleeve will be damaged!

# TAP Dimensions

## Shank Diameter of Taps

Thread		ISO 529*		ISO 2283		DIN 371		DIN 357 DIN 376		DIN 352		JIS B 4430 1998 Annex		ANSI B 94.9 1999	
[mm]	[Inch]	[Ø]	[→]	[Ø]	[→]	[Ø]	[→]	[Ø]	[→]	[Ø]	[→]	[Ø]	[→]	[Ø]	[→]
M 1.0		2.50	2.00	–	–	2.50	2.10	–	–	2.50	2.10	3.00	2.50	–	–
M 1.1		2.50	2.00	–	–	2.50	2.10	–	–	2.50	2.10	3.00	2.50	–	–
M 1.2		2.50	2.00	–	–	2.50	2.10	–	–	2.50	2.10	3.00	2.50	–	–
M 1.4	#0-6 1/16	2.50	2.00	–	–	2.50	2.10	–	–	2.50	2.10	3.00	2.50	–	–
M 1.6		2.50	2.00	–	–	2.50	2.10	–	–	2.50	2.10	3.00	2.50	0.141"	0.110"
M 1.7		–	2.00	–	–	2.50	2.10	–	–	2.50	2.10	3.00	2.50	–	–
M 1.8		2.50	2.00	–	–	2.50	2.10	–	–	2.50	2.10	3.00	2.50	0.141"	0.110"
M 2.0		2.50	2.00	–	–	2.80	2.10	–	–	2.80	2.10	3.00	2.50	0.141"	0.110"
M 2.2		2.80	2.24	–	–	2.80	2.10	–	–	2.80	2.10	3.00	2.50	0.141"	0.110"
M 2.3		–	–	–	–	2.80	2.10	–	–	2.80	2.10	3.00	2.50	–	–
M 2.5	3/32	2.80	2.24	–	–	2.80	2.10	–	–	2.80	2.10	3.00	2.50	0.141"	0.110"
M 2.6		–	–	–	–	2.80	2.10	–	–	2.80	2.10	3.00	2.50	–	–
M 3.0	1/8	3.15	2.50	2.24	1.80	3.50	2.70	2.20	–	3.50	2.70	4.00	3.20	0.141"	0.110"
M 3.5		3.55	2.80	2.50	2.00	4.00	3.00	2.50	2.10	4.00	3.00	4.00	3.20	0.141"	0.110"
M 4.0	5/32	4.00	3.15	3.15	2.50	4.50	3.40	2.80	2.10	4.50	3.40	5.00	4.00	0.168"	0.131"
M 4.5	3/16	4.50	3.55	3.55	2.80	6.00	4.90	3.50	2.70	6.00	4.90	5.00	4.00	0.194"	0.152"
M 5.0		5.00	4.00	4.00	3.15	6.00	4.90	3.50	2.70	6.00	4.90	5.50	4.50	0.194"	0.152"
M 6.0	1/4	6.30	5.00	4.50	3.55	6.00	4.90	4.50	3.40	6.00	4.90	6.00	4.50	0.255"	0.191"
M 7.0		7.10	5.60	5.60	4.50	7.00	5.50	5.50	4.30	6.00	4.90	6.20	5.00	0.318"	0.238"
M 8.0		8.00	6.30	6.30	5.00	8.00	6.20	6.00	4.90	6.00	4.90	6.20	5.00	0.318"	0.238"
M 9.0		9.00	7.10	7.10	5.60	9.00	7.00	7.00	5.50	7.00	5.50	7.00	5.50	–	–
M 10.0	3/8	10.00	8.00	8.00	6.30	10.00	8.00	7.00	5.50	7.00	5.50	7.00	5.50	0.381"	0.286"
M 11.0		8.00	6.30	8.00	6.30	–	–	8.00	6.20	8.00	6.20	8.00	6.00	–	–
M 12.0	1/2	9.00	7.10	9.00	7.10	–	–	9.00	7.00	9.00	7.00	8.50	6.50	0.367"	0.275"
M 14.0	9/16	11.20	9.00	11.20	9.00	–	–	11.00	9.00	11.00	9.00	10.50	8.00	0.429"	0.322"
M 16.0		12.50	10.00	12.50	10.00	–	–	12.00	9.00	12.00	9.00	12.50	10.00	0.480"	0.360"
M 18.0	11/16	14.00	11.20	14.00	11.20	–	–	14.00	11.00	14.00	11.00	14.00	11.00	0.542"	0.406"
M 20.0	13/16	14.00	11.20	14.00	11.20	–	–	16.00	12.00	16.00	12.00	15.00	12.00	0.652"	0.489"
M 22.0		16.00	12.50	16.00	12.50	–	–	18.00	14.50	18.00	14.50	17.00	13.00	0.697"	0.523"
M 24.0	15/16	18.00	14.00	18.00	14.00	–	–	18.00	14.50	18.00	14.50	19.00	15.00	0.760"	0.570"
M 27.0	1/16	20.00	16.00	–	–	–	–	20.00	16.00	20.00	16.00	20.00	15.00	0.896"	0.672"
M 30.0		20.00	16.00	–	–	–	–	22.00	18.00	22.00	18.00	23.00	17.00	1.021"	0.766"

\*M3 - M10 with reinforced shank

All dimensions in mm (except US Standard ANSI B 94.9 in Inch)



Swiss  
Precision  
Tools

## Legal Notices

The products described in this catalog are specified to the best of our knowledge. The data given herein is dependent on the conditions under which they are measured and are derived from tests carried out under defined lab conditions at REGO-FIX AG. The performance of these tools depends on the conditions under which they are used and may vary from case to case. The information given in this catalog is believed to be correct. REGO-FIX® however assumes no responsibility or liability for any errors, inaccuracies or omissions that may appear in this catalog.

Information in this catalog is subject to change without notice and should not be construed as a commitment by REGO-FIX® or its subsidiaries. This is especially valid for adaptations to new or changed international standards or improvements to the products performance or production processes.

No part of this document may be reproduced or transmitted in any form or by any means, electronic or mechanical, for any purpose, without the express written permission of REGO-FIX®.

REGO-FIX®, powRgrip®, ER System®, Hi-Q® and Q+® are registered trademarks of REGO-FIX AG.

Softsynchro® is a registered trademark of EMUGE-Werk Richard Glimpel GmbH & Co. KG.

Viton® is a brand of synthetic rubber and fluoropolymer elastomer of DuPont.



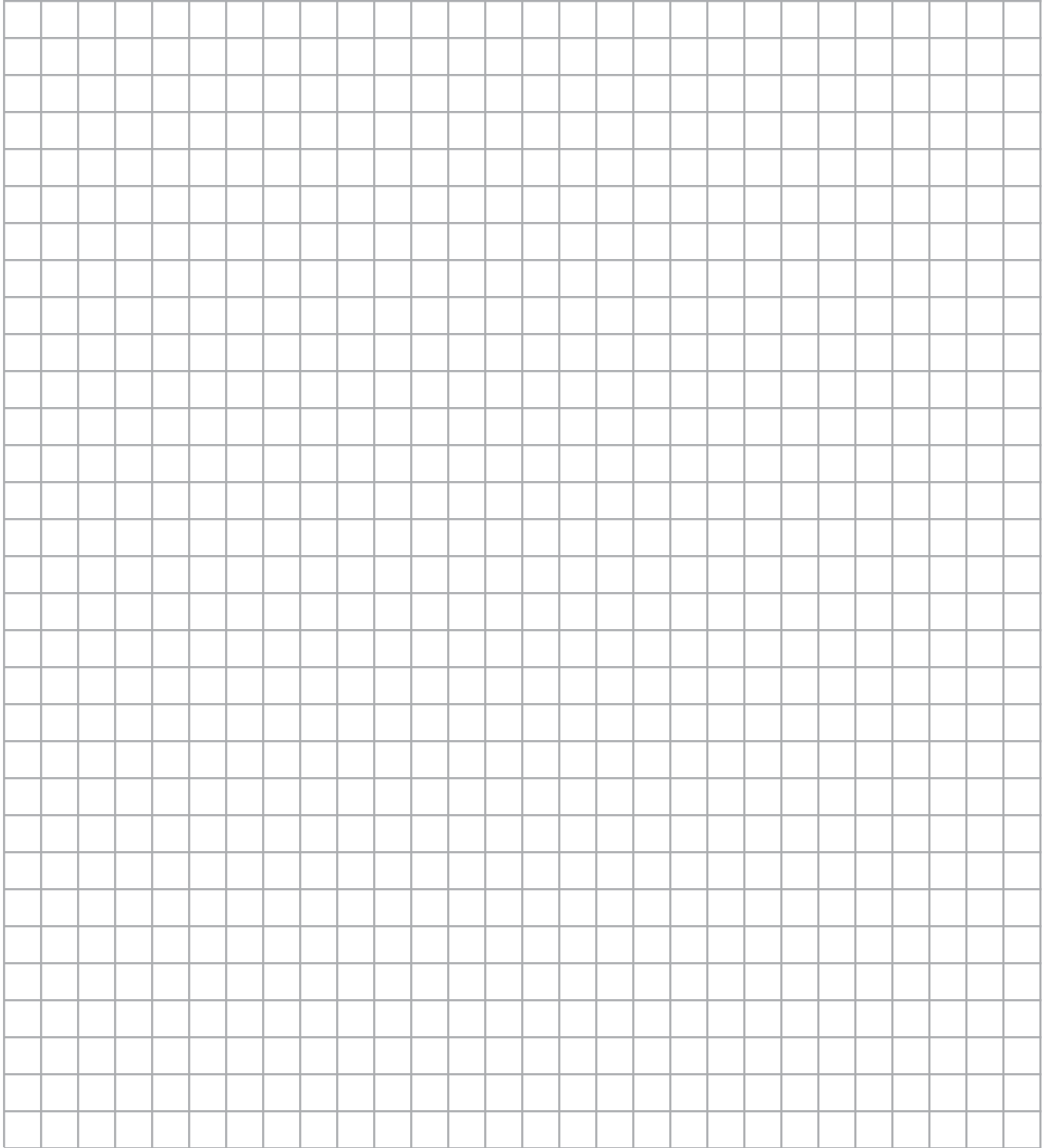





Swiss  
Precision  
Tools