



15150 25th Avenue North, Minneapolis, MN 55447-1981  
 Phone 763-476-8600 Fax 763-476-4092  
 Service Dept: MN-763-476-4191 IA-319-632-4288 NE-402-330-2323  
 Visit us at: [www.productivity.com](http://www.productivity.com) Productivity is ISO 9001:2000 Certified

Productivity Inc®

**PIC Nakamura Super NTY3 Pre-Installation Checklist – Rev 06/2009**

Installation of your new Nakamura Super NTY3 can be smooth and rapid if preparations are made prior to the delivery of your machine. Any questions regarding machine installation should be directed to our service department for clarification. We hope this checklist will aid in a rapid installation of your new machine. **NOTE: The following must be completed prior to our service technician arriving to install the machine.**

- Power Requirements for your machine: \*220v/3 phase/75 kVa Amps: 241 Amp  
 Proper voltage per machine specifications should be ready at machine site. **Do NOT power up the machine. \*NOTE: 220v minimum, 240v maximum. Voltage in excess of 240v may cause extensive damage to the machine's electrical system and will void the machine's warranty. A separate earth ground wire of the same conductor size as the input power must be connected to the chassis of the machine; must be supplied from the main plant ground. A local cold-water pipe or ground rod is not sufficient.**
- Customer should furnish and have available the proper supply and types of lubricants required for machine operation.

ITEM	CAPACITY	FLUID TYPE
Coolant	52 Gal	Water Soluable, Synthetic
Way Lube	1.2 Gal	Mobil Vactra #2
Hydraulic Oil	23 Gal	Mobil DTE Light

**You will need to have these lubricants on hand at time of installation. Contact our Service Department with any questions or concerns regarding Power and/or Lubrication Requirements.**

- Air lines should be routed to the machine location and operational for proper air pressure.

Minimum air pressure of 0.5-0.7MPa
------------------------------------

- Machine location should be planned to allow enough room for access panels to be opened and serviced with ease. *Allow an extra 36" behind the machine for maintenance, and an additional 40" to the right side of the machine if optional Chip Conveyor is purchased.*
- Weight requirements should be checked to insure that the surface below the machine will have sufficient strength for support and stability. The machine must be set on a solid, sound and stable, steel bar-reinforced concrete slab poured directly on the grade. In general, the 6-12" concrete floor on industrial buildings is suitable for machine placement. Bolting the machine to the floor is not required.
- **The Nakamura Super NTY3 Turning Center is best moved with a forklift. Upon arrival of your machine, unpack and immediately check for visible damage. Call Hope immediately – you will need to take pictures and email to [hriska@productivity.com](mailto:hriska@productivity.com). Make sure you note on BOL BEFORE the driver leaves.**

SHIPPING WEIGHT	SHIPPING DIMENSIONS OF MACHINE
17,900# (Machine & Acc Crate)	10' L x 7' W x 7'7" H (Machine)
5,644# (Accessory)	13'5" L x 6'6" W x 5'3" H (Accessory Crate)
1,874# (Accessory)	6'10" L x 3'10" W x 7'1" H (Accessory Crate)
1,527# (Optional Lift Up Chip Conveyor)	10' L x 3'5" W x 5' H (Optional Lift Up Chip Conveyor, skidded)
<i>See attached layout for Operational Dimensions (Floor Space): Wt: 17,637# (with Chip Conveyor, allow an additional 40" to the right side for the CC) Also allow for maintenance around machine (40")</i>	

- Remove as much preservative from the machine as possible without having to power up (tables – slides, pulleys, etc.). We recommend mineral spirits to clean. Apply oil when finished to prevent rust.

**PLEASE FORWARD THIS TO THE APPROPRIATE PERSON. THANK YOU.**

Table 4-9 Recommended Oil Table

Maker	Lubricating Oil	Hydraulic Oil	Grease		Lubricating Oil	Hydraulic Oil
	VG68	VG32			VG68	VG2 to 10
Idemitsu	Daphne Super Multi Oil 68	Daphne Super Multi Oil 32	Daphne Molybdenum grease	Daphne Super Coronex No.2	Daphne Super Multi Oil 68	
Shell	Tonna Oil T68 or A-R Oil 68	Tellus Oil C32 or J-H Oil 32	Lethinax AM or Sunlight grease MB2	Alvania Grease 2 or Sunlight Grease 2		
Mobil	Mobil Vactra Oil No. 2	Mobil DTE Oil Light	Mobil Grease Special	Mobil Mobilux 2	Mobil DTE Oil 26	
Mitsubishi	Diamond slideway 68	Diamond Lub RO32	Diamond Multi purpose M grease 2	Diamond Multi Purpose grease No.2		
Fuji	Lubmulti 68	Lubmulti 32		Mighty grease No.2		
Nisseki	Uniway 68	FBK Oil R032	Molynoc grease 2	Multinoc grease 2	FBK Oil RO68	
Cosmo	Mightyway 68	Hydro RO32	Molybdenum grease	Grease Dynamax Super No.2	Mighty super 68	
Exxon	Febis K68	Terreso 32	Beacon Q2	Lithtan 2	Terreso 68	
Kygnus	Waylubricant 80	Unit Oil P32	M-5 Grease No. 2	MP Grease No. 2		
Kyodo	Slidus 68	RIX turbine 32	Lisonix grease M-2	Lisonix grease 2		
General	Slideoil 68	General panol 32	Gemico grease AD-2	Gemico grease MP-2		
Mitsui	Slideway E68	Hydic oil 32		Multi grease EP-2		
NOK Fleuber			Multemp Q NB50			
Three bond			Three bond 1901			
Castrol	Magnaglide BD68	Hyspin AWS32	Spheerol LMM	Spheerol AP2		
Remark (Oiling drive Point)	Centralized lubricating oil tank	Hydraulic oil tank	Jaw chuck	Rotary tool holder	Milling index Gear case (micron-lub lubrication unit)	Oil cooler (spindle cooling)

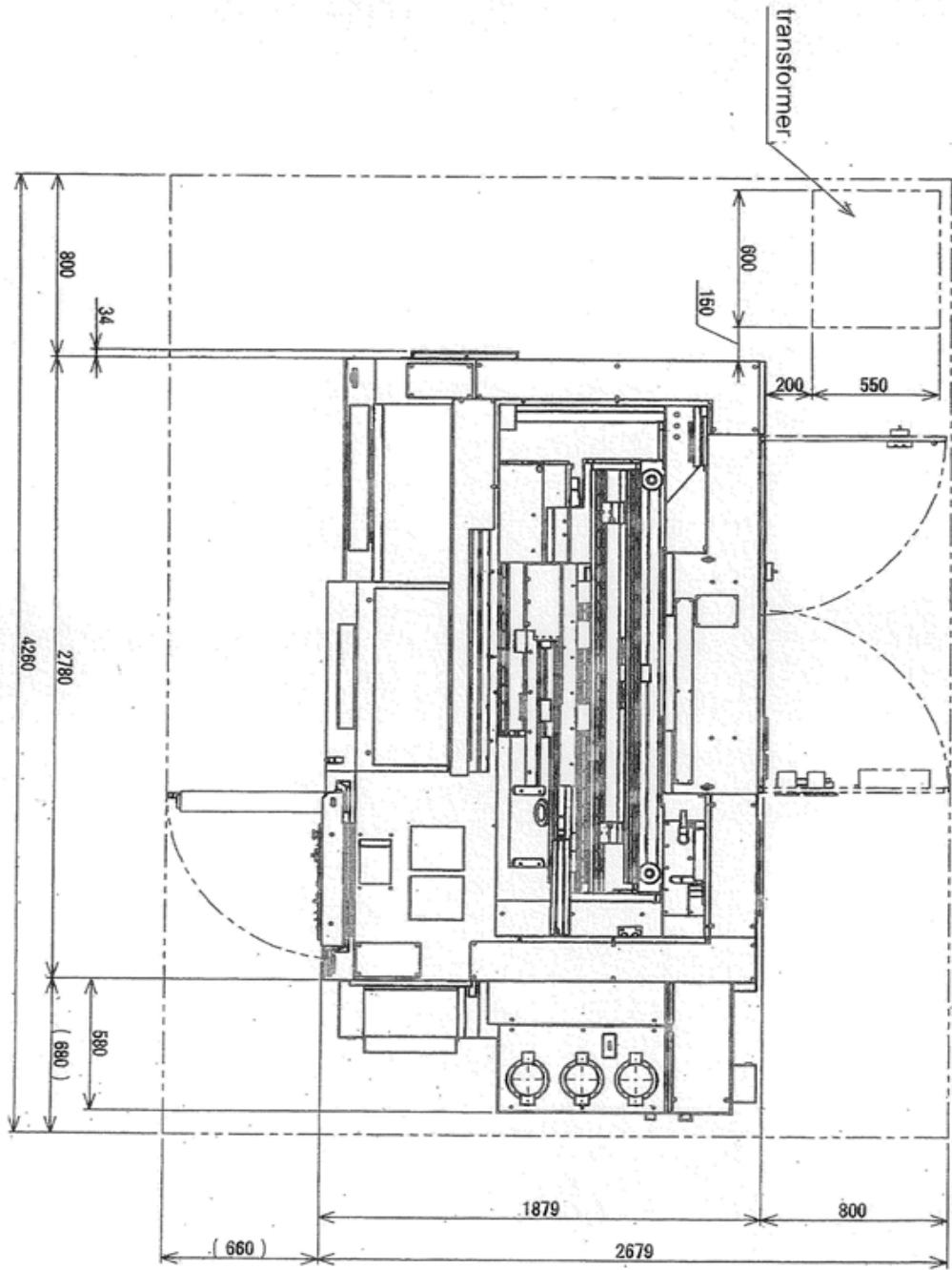

SuperNTY<sup>3</sup>  
 - Floor space -  
 with HP coolant pumps

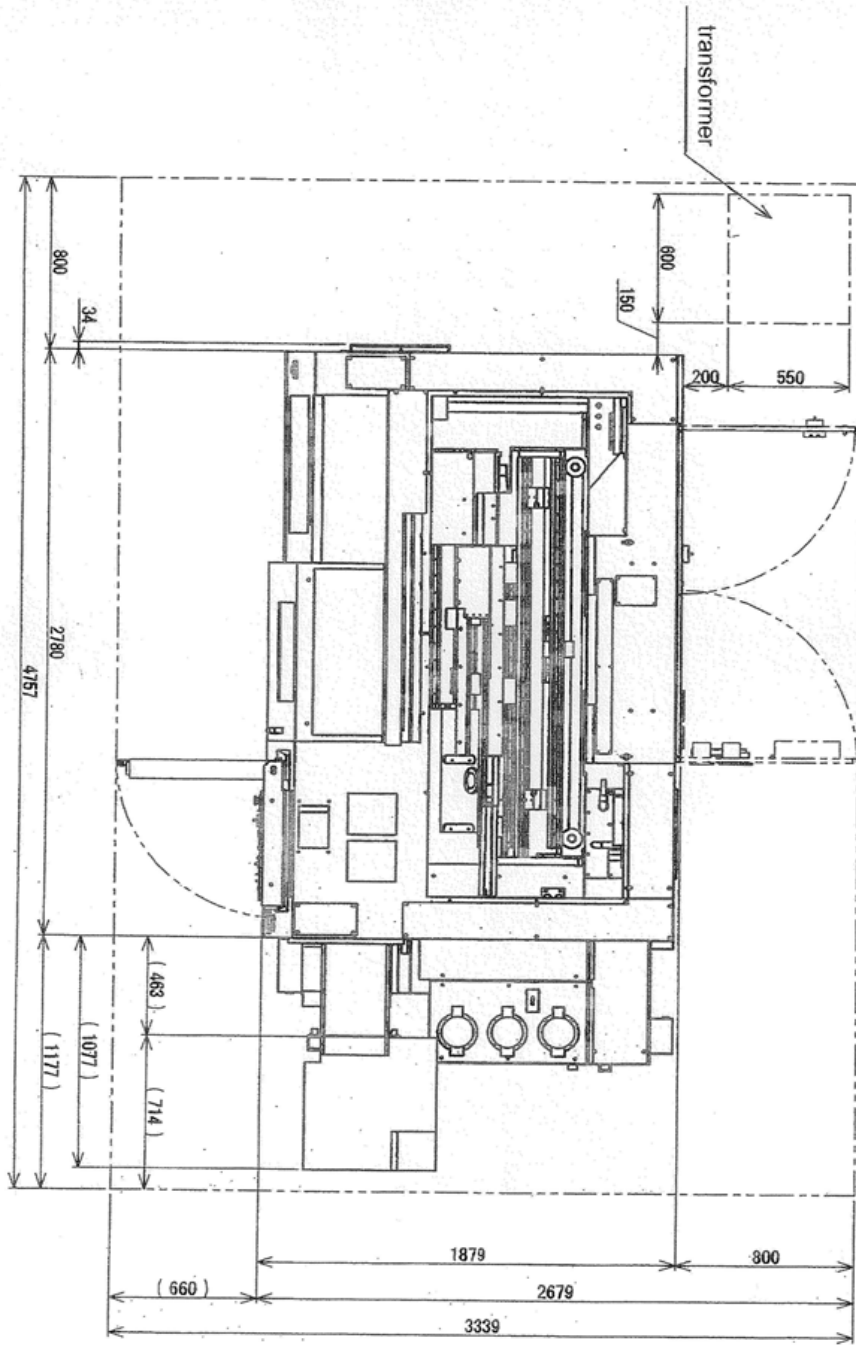

SuperNTY<sup>3</sup>  
 - Floor space -  
 with chin conveyor

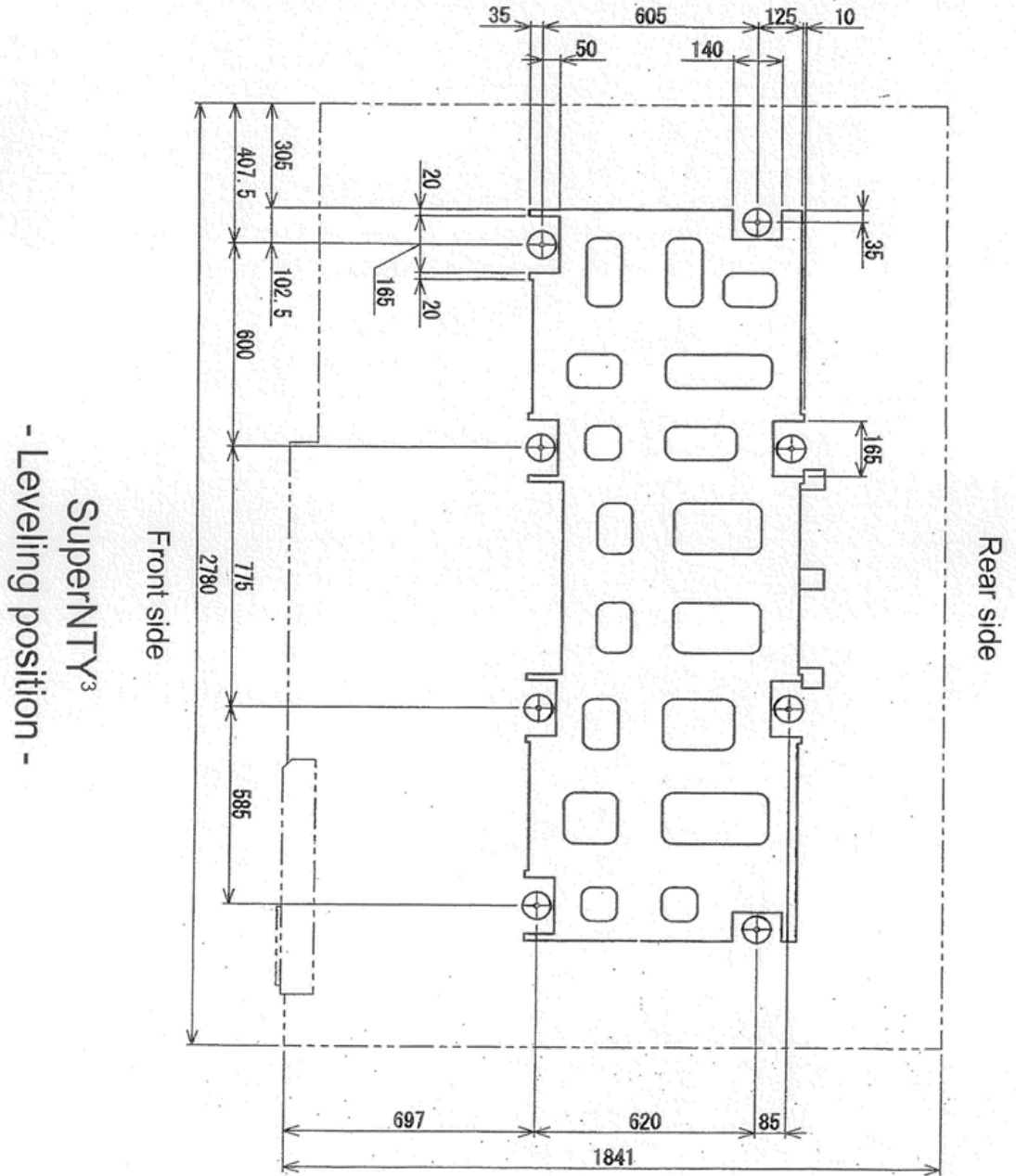

SuperNTY<sup>3</sup>  
 - Leveling position -

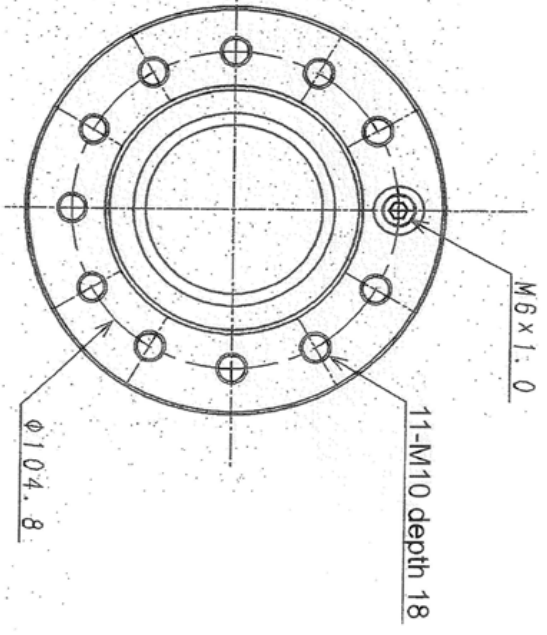
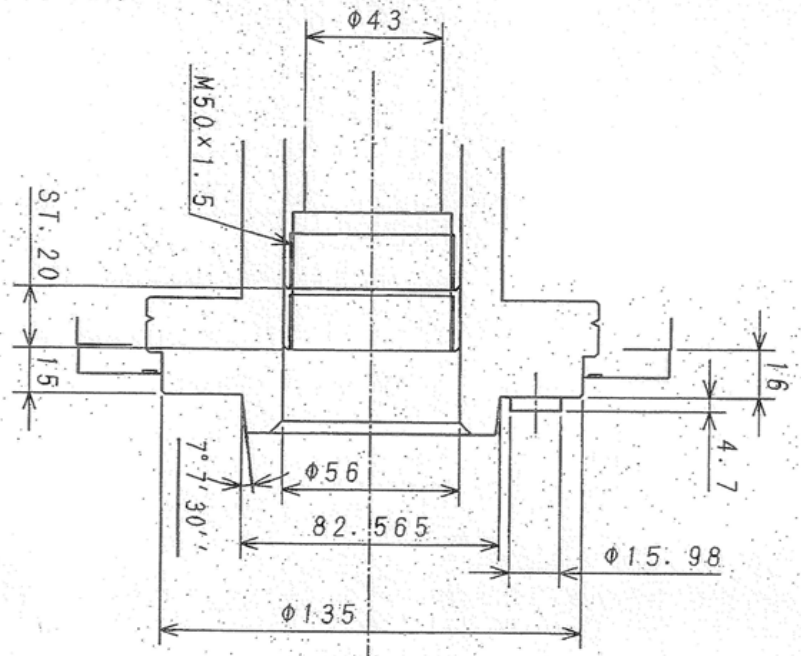

SuperNTY<sup>3</sup>  
 - L/R Spindle nose -  
 dia.42mm/A2-5/6,000min-1

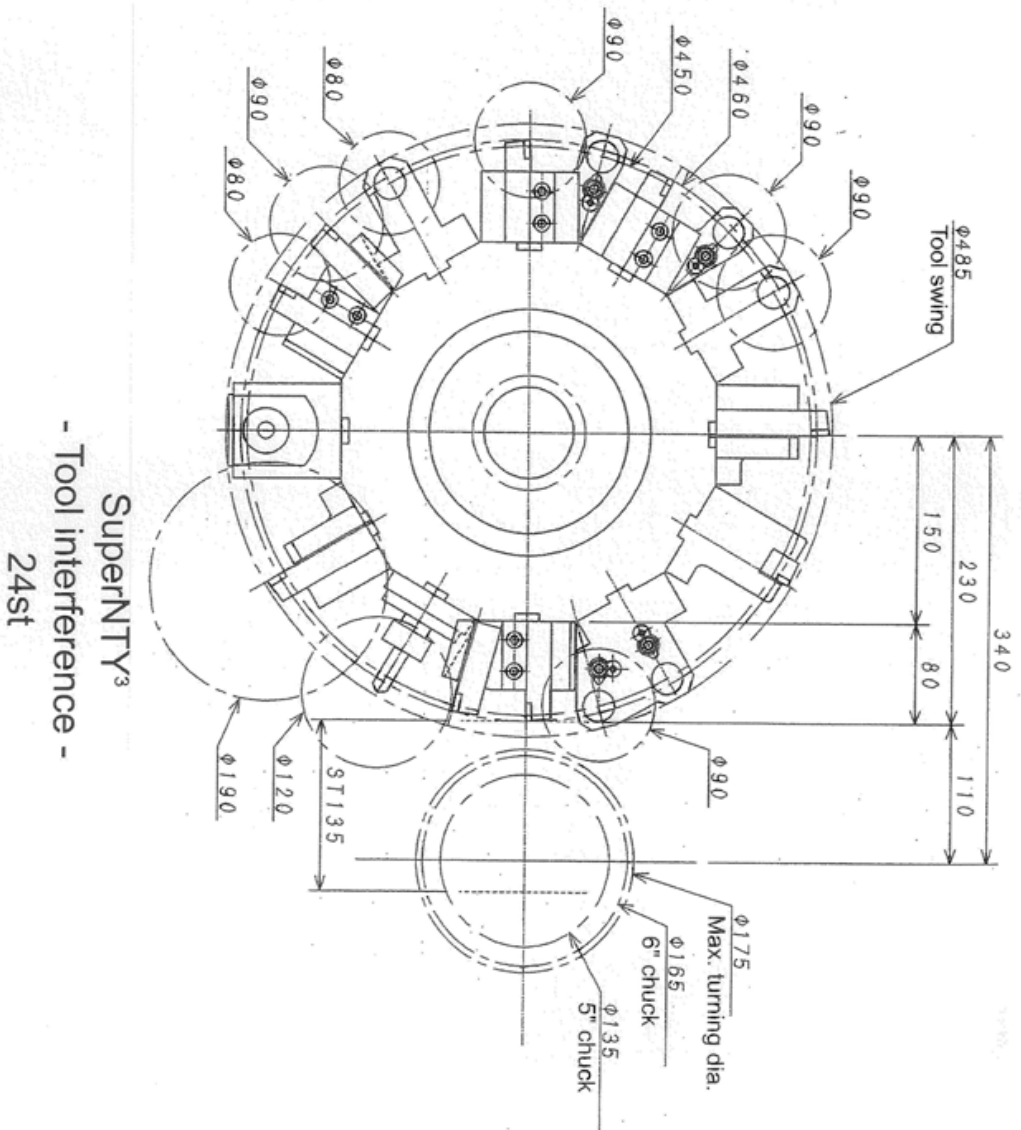

SuperNTY<sup>3</sup>

- Tool interference -  
24st

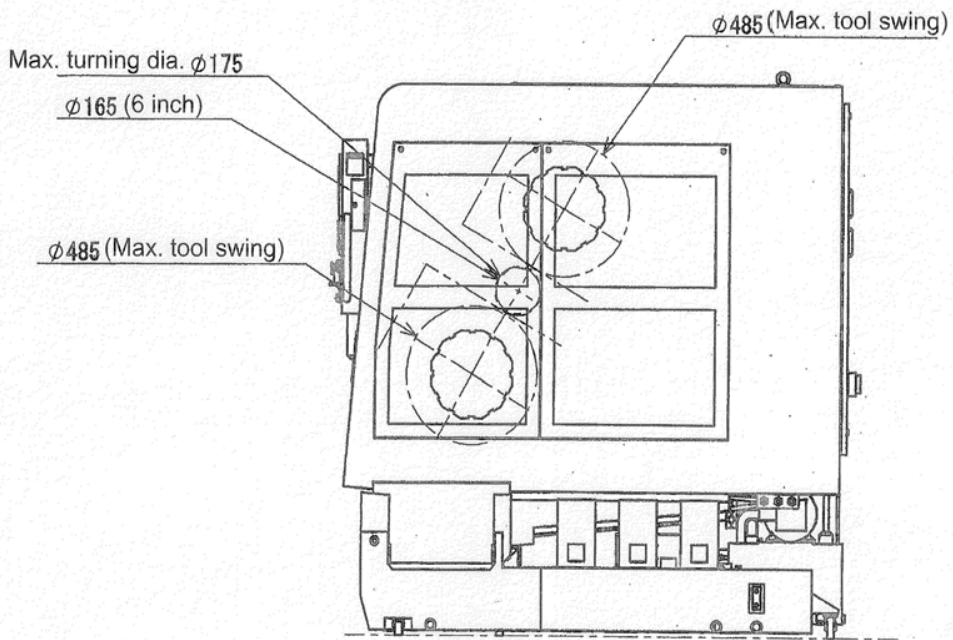

SuperNTY<sup>3</sup>  
 - Tool swing -

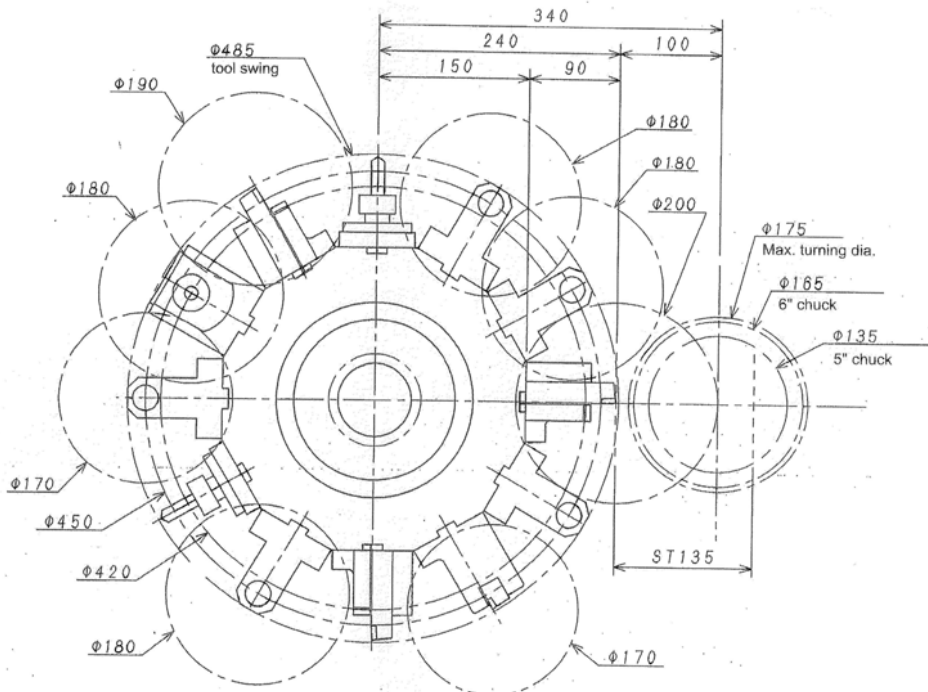

SuperNTY<sup>3</sup>  
 - Tooling interference -  
 12st

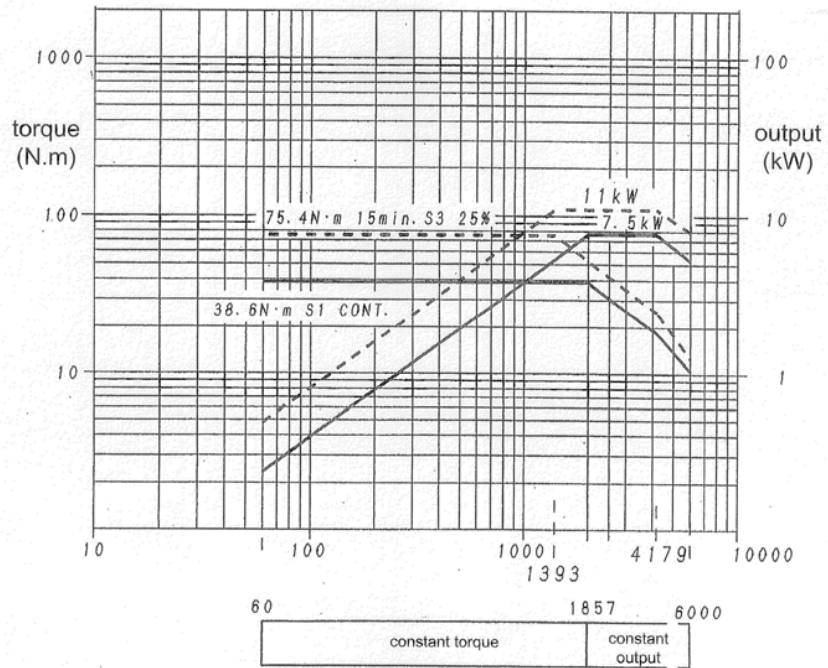

SuperNTY<sup>3</sup>  
 - Speed/Torque/Output -  
 L/R spindle

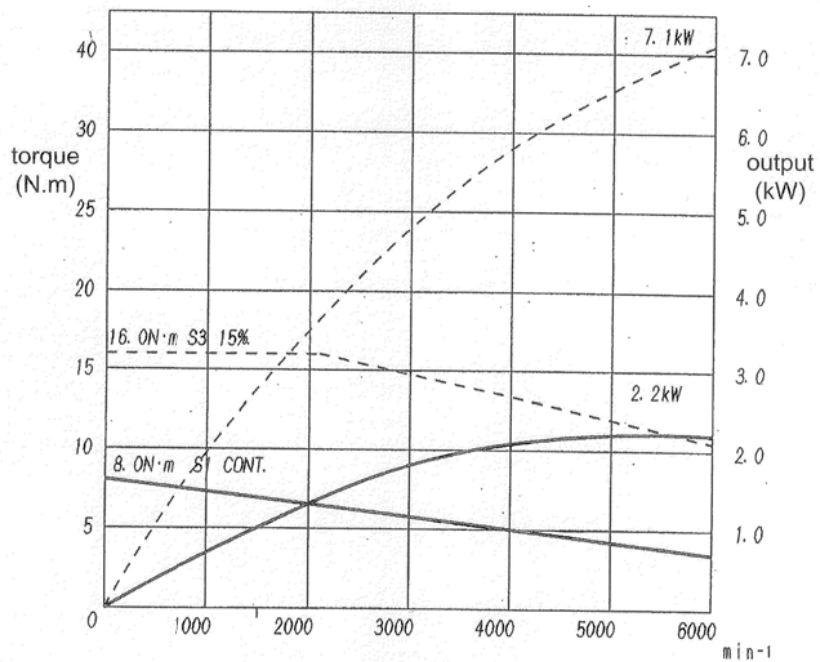

SuperNTY<sup>3</sup>  
 - Speed/Torque/Output -  
 Rotating tool