



Productivity Inc®

VF-4 PRE-INSTALLATION CHECKLIST - Rev 01/2009

Installation of your new Haas VF-4 can be smooth and rapid if preparations are made prior to the delivery of your machine. Any questions regarding machine installation should be directed to our service department for clarification. We hope this checklist will aid in a rapid installation of your new machine. **NOTE: The following must be completed prior to our service technician arriving at your facility.**

- Power Requirements ** for your machine: 230v/3ph/14kVa 50 amps (*460v/3ph/14kVa, 25 Amps) Proper voltage per machine specifications should be ready at machine site. **Do NOT power up machine. A separate earth ground wire of the same conductor size as the input power must be connected to the chassis of the machine; must be supplied from the main plant ground. A local cold-water pipe or ground rod is not sufficient.** *460v requires an Internal or External Transformer.
****NOTE: HT10K (30HP) option requirements: 230v/3ph/28kVa, 100 Amp (460v/3ph/28kVa, 50 Amp)**

*****NOTE: If you have purchased the 1000 psi High Pressure Coolant option, you will need a separate power source. 208-230v/3ph/20 Amp circuit is needed for the unit. The CNC does NOT provide the power source. Any questions, please contact our Service Department.*****

- Customer should furnish and have available the proper supply and types of lubricants required for machine operation.

ITEM	CAPACITY	FLUID TYPE
Coolant	55 gallons (80 gal with Opt 80-gal tank)	Water Soluble, synthetic
Way Lube	80 ounces	Mobil Vactra #2**

You will need to have Coolant and lubricants on hand at the time of installation. Contact our Service Department for more information.

- Air lines should be routed to the machine location and operational for proper air pressure.

The VMC requires a minimum of 100 PSI at 4 cfm (w/optional AAG Auto Air Gun, 10 scfm) at the input to the pressure regulator on the back of the machine. This should be supplied by at least a 1-HP compressor, with a minimum 20-gal tank, that turns on when the pressure drops to 100 PSI. The air must be supplied through a minimum 3/8" I.D. hose and fittings must be at least 1/4" NPT.

- Machine location should be planned to allow enough room for access panels to be opened and serviced with ease. *A minimum of 36" clearance around the machine is required.*
- Weight requirements should be checked to insure that the surface below the machine will have sufficient strength for support and stability. The machine must be set on a solid, sound and stable, steel bar-reinforced concrete slab poured directly on the grade. In general, the 6" concrete floor on industrial buildings is suitable for machine placement.
- **The Haas VF-4 should be moved with a forklift. Notify Hope immediately if you plan to use a crane. Upon arrival of your machine, uncrate and immediately check for visible damage.**

SHIPPING WEIGHT	SHIPPING DIMENSIONS (<i>Over 10'2" requires double-drop trailer.</i>)
13,500# (skidded/wrapped)	12' L x 8'6" W x 10' H (Skidded/Wrapped) (w/24-tool SMTC)
14,800# (40-Tool SMTC)	12'8" L x 8'6" W x 10'6" (w/40-Tool SMTC)
Oper: 13,300# See attached for layout/floor space requirements. (Allow an additional 36" in back of the machine for maintenance, and approximately 4' on the left side for the Chip Conveyor Chute.)	

- Remove as much preservative from the machine as possible without having to power up (tables – slides, pulleys, etc.). We recommend mineral spirits to clean. Apply oil when finished to prevent rust.

VF-4 Dimensions

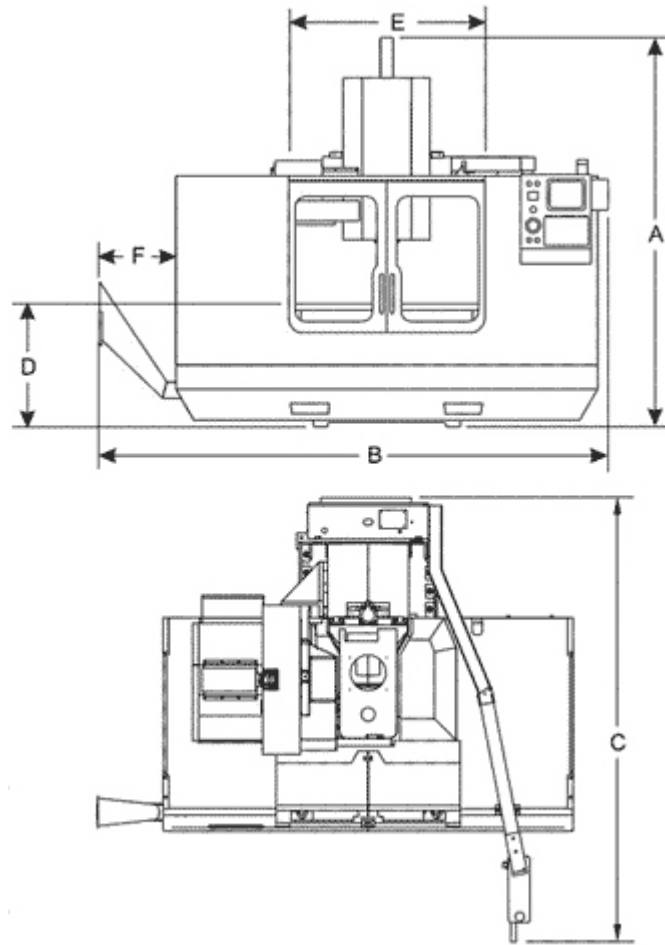

	Mix View	
A NOTE: Add 4" when EC4 (Extended Z) option is purchased.	119 "	
B	150 "	
C	135 "	
D	37 "	
E	49 "	
F	21 "	

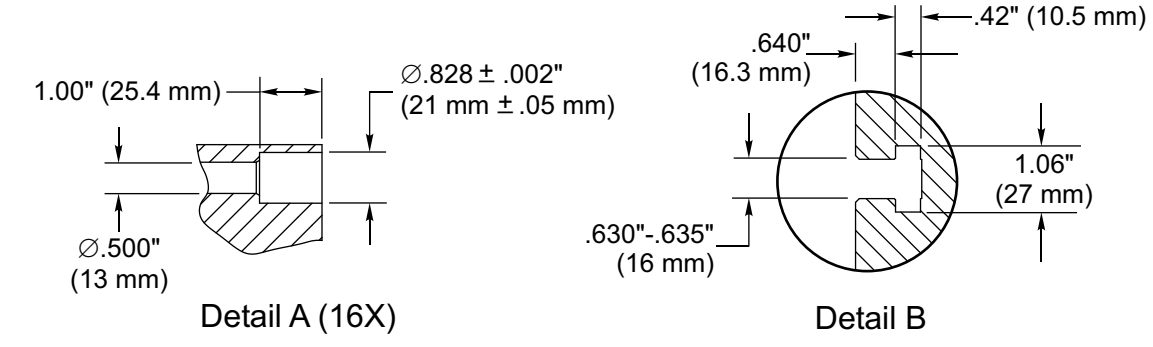
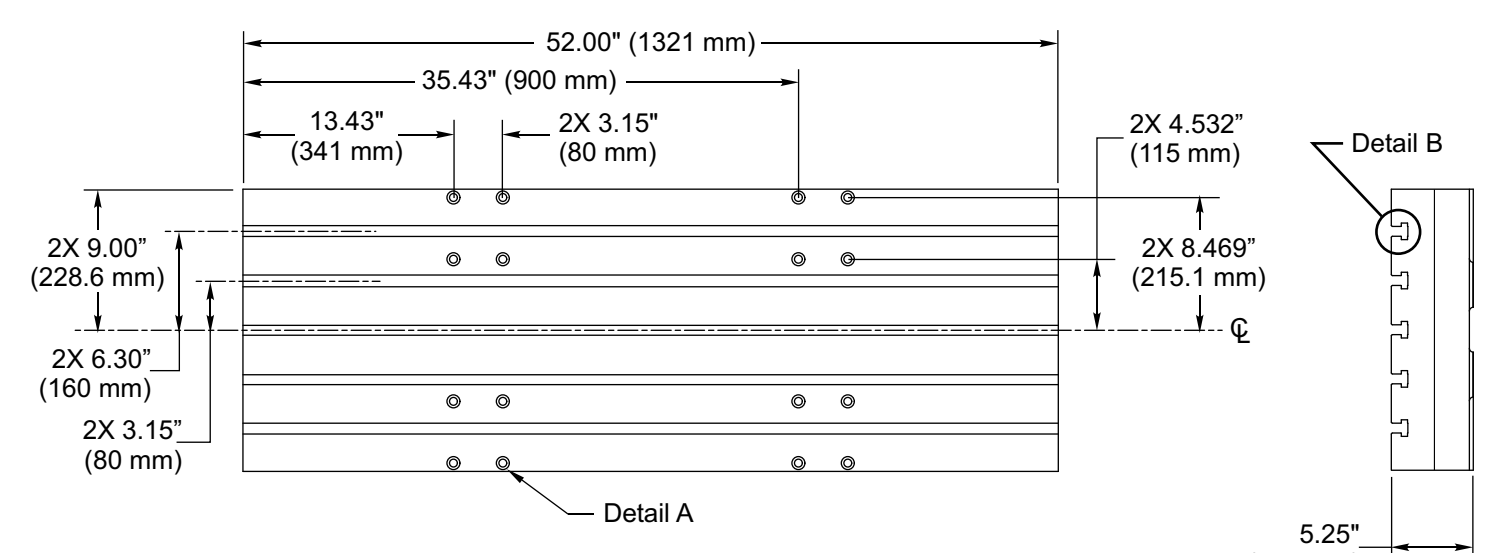
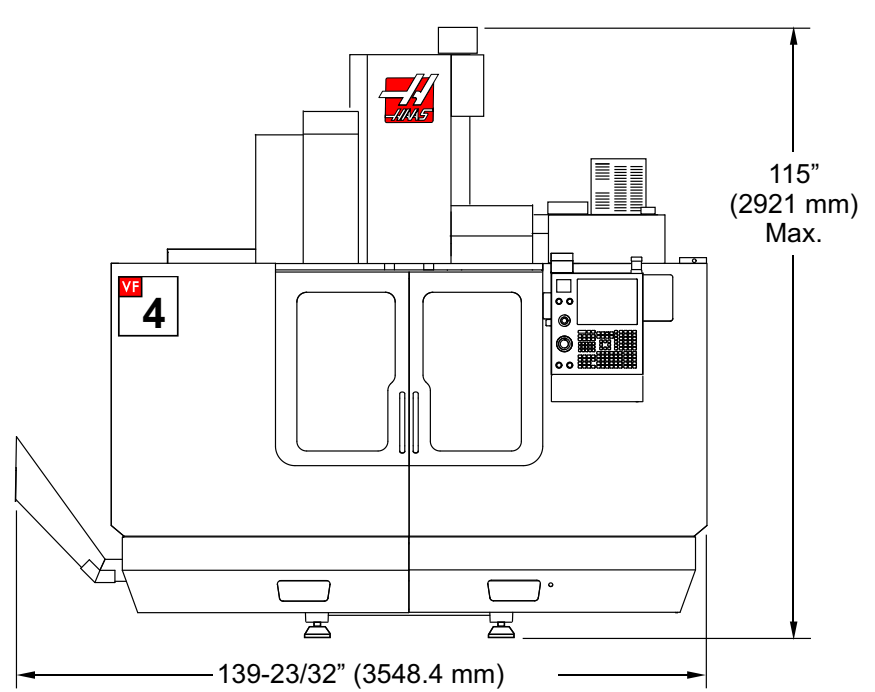
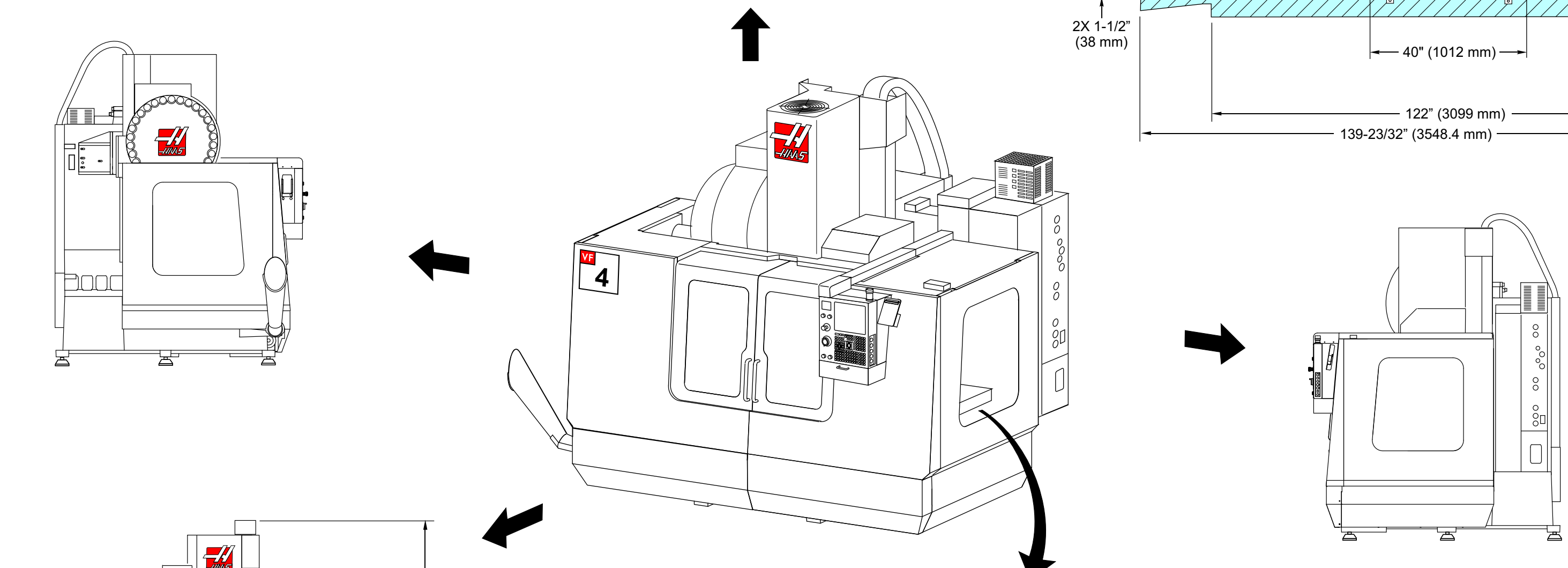
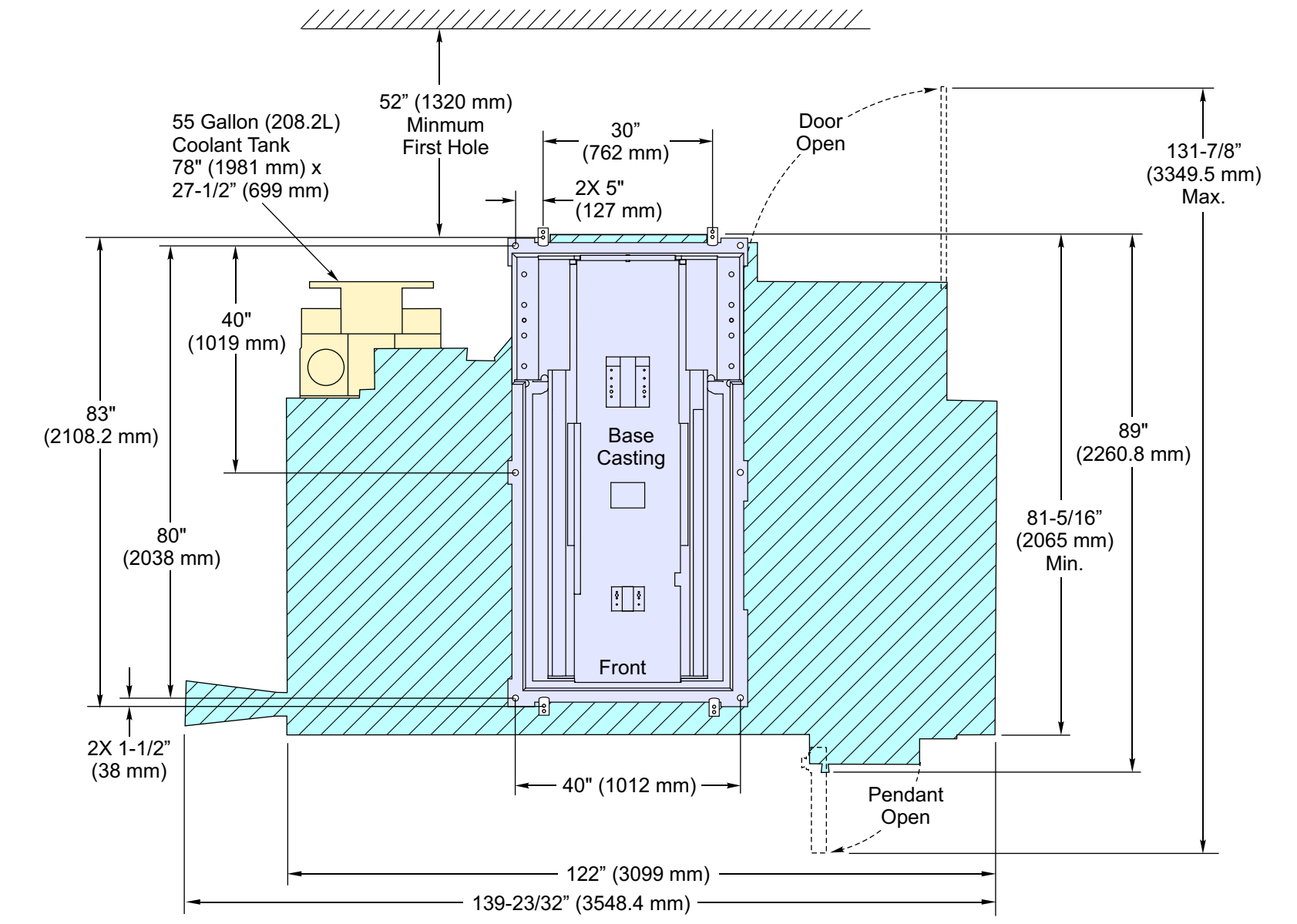
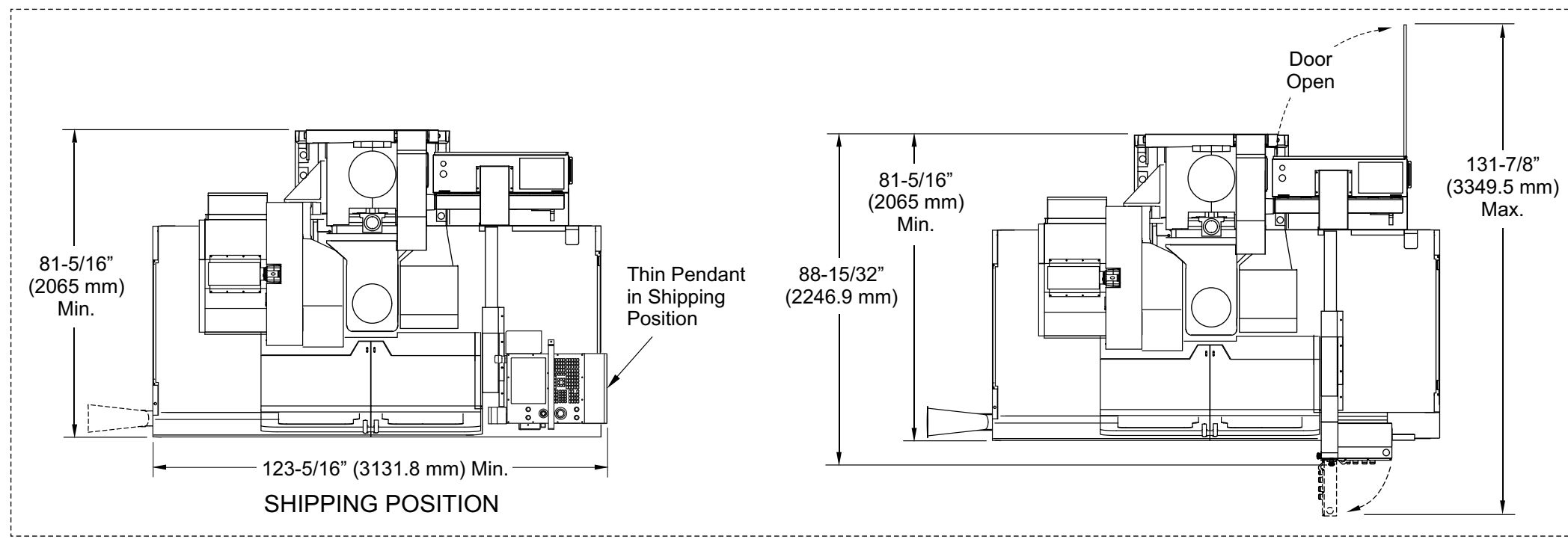

VF-4 Table Dimensions

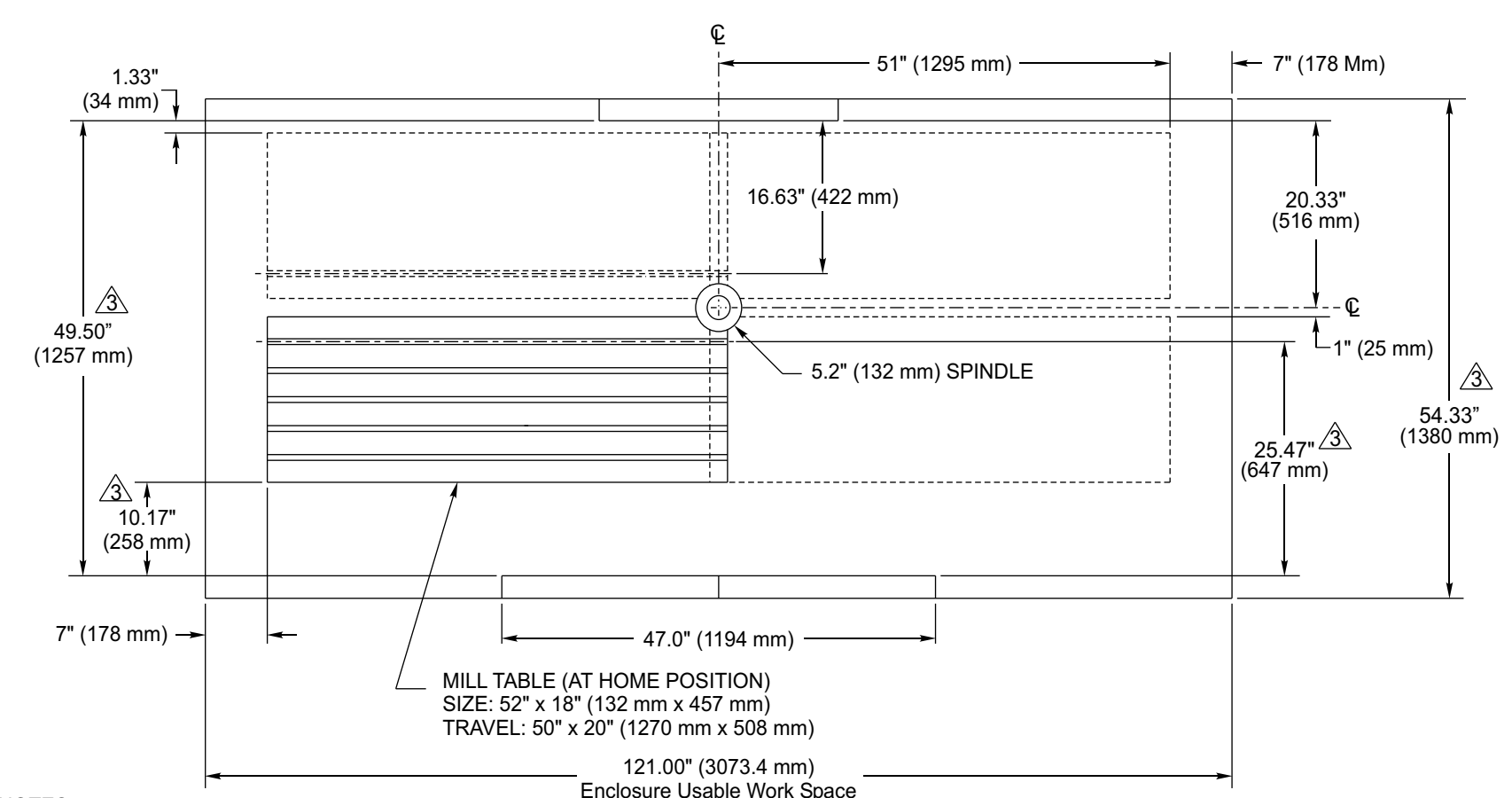

NOTES:
 1. TABLE POSITION(S) AT MAX X & Y TRAVELS.
 2. MEASUREMENTS ARE FROM THE EDGE OF MILL TABLE TO NEAREST OBSTRUCTION (ie. ENCLOSURE, WAY COVER, DOORS, ETC.).
 3. DIMENSIONS ARE REDUCED AS HEIGHT ABOVE TABLE INCREASES; ie. FRONT OF ENCLOSURE IS SLOPED 5 INWARD FROM BOTTOM TO TOP. DIMENSIONS SHOWN ARE AT TABLE TOP HEIGHT.

Top View

VF-4 Enclosure Work Space

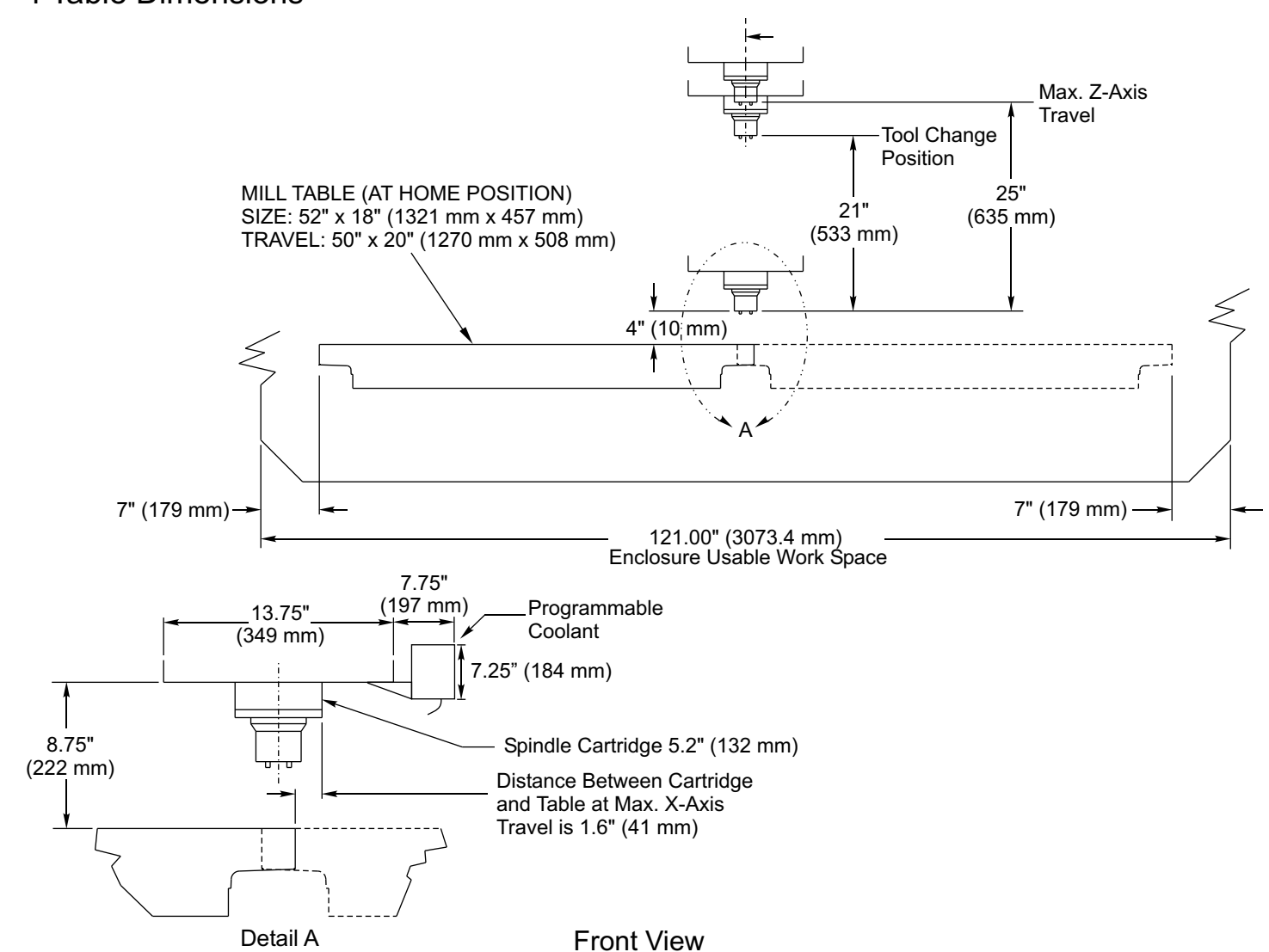

Front View

Drawing Name: VF-4_Thin Pendant Machine Views.cdr
 Network Path: Graphics\VF-3 -412-D Machine Views
 Last Updated: 10/31/08
 Drawn By: G. Grajeda
 Change Description:
 First Release