



Productivity, Inc.®

VF-2SS and VF-2SSYT PRE-INSTALLATION CHECKLIST . Rev 1/2009

Installation of your new Haas VF-2SS/VF-2SSYT w/12K RPM/30HP can be smooth and rapid if preparations are made prior to the delivery of your machine. Any questions regarding machine installation should be directed to our service department for clarification. We hope this checklist will aid in a rapid installation of your new machine. **NOTE: The following must be completed prior to our service technician arriving at your facility.**

- Power Requirements for your machine: 230v/3ph/28kVa 100 Amps** (*460v/3ph/28kVa 50 Amp)
 Proper voltage per machine specifications should be ready at machine site. **Do NOT power up machine. A separate earth ground wire of the same conductor size as the input power must be connected to the chassis of the machine; must be supplied from the main plant ground. A local cold-water pipe or ground rod is not sufficient.** *NOTE: 460v requires an External Transformer. **The machine will draw 70 Amps.

*****NOTE: If you have purchased the 1000 psi High Pressure Coolant option, you will need a separate power source. 208-230v/3ph/20 Amp circuit is needed for the unit. The CNC does NOT provide the power source. Any questions, please contact our Service Department.*****

- Customer should furnish and have available the proper supply and types of lubricants required for machine operation.

ITEM	CAPACITY	FLUID TYPE
Coolant	55 gal (95 gal optional)	Water Soluble, synthetic
Way Lube	80 oz	Mobil Vactra #2 (40T w/30K uses DTE25)

You will need to have Coolant and Lubricants on hand at time of installation. Contact our Service Department for more information or questions.

- Air lines should be routed to the machine location and operational for proper air pressure.

The VMC requires a minimum of 100 PSI at 4 scfm (w/optional AAG Auto Air Gun, 10 scfm) at the input to the pressure regulator on the back of the machine. This should be supplied by at least a 2-HP compressor, with a minimum 20-gal tank, that turns on when the pressure drops to 100 PSI. The air must be supplied through a minimum 3/8" I.D. hose and fittings must be at least 1/4" NPT.

- Machine location should be planned to allow enough room for access panels to be opened and serviced with ease. A minimum of 36" clearance around the machine is required for operator access and maintenance.
- Weight requirements should be checked to insure that the surface below the machine will have sufficient strength for support and stability. The machine must be set on a solid, sound and stable, steel bar-reinforced concrete slab poured directly on the grade. In general, the 6" concrete floor on industrial buildings is suitable for machine placement.
- **The Haas VF-2SS should be moved with a forklift. Notify Hope immediately if you plan to use a crane. Upon arrival of your machine, uncrate and immediately check for visible damage.**

SHIPPING WEIGHT	SHIPPING DIMENSIONS OF MACHINE
8,280 # (skidded VF-2SS)	8'6" L x 8'6" W x 9'4" H (skidded and wrapped VF-2SS)
8,520 # (skidded VF-2SSYT)	9'8" L x 8'6" W x 8'6" H (skidded/wrapped VF-2SSYT)
300 # (optional G95 Tank)	4'7" L x 7'4" W x 3' H (optional G95-Gal Coolant Tank if ships separate)
Oper: 7,100 # See attached for operational/floor space requirements. (Allow an additional 4 feet to the left side of the machine for the Chip Conveyor Chute/Disposal.) Oper Wt: 8,000# (VF-2SS) 8,400# (VF-2SSYT)	

- Remove as much preservative from the machine as possible without having to power up (tables – slides, pulleys, etc.). We recommend mineral spirits to clean. Apply oil when finished to prevent rust.

VF-2SS Dimensions/Layout/Floor Space Requirements

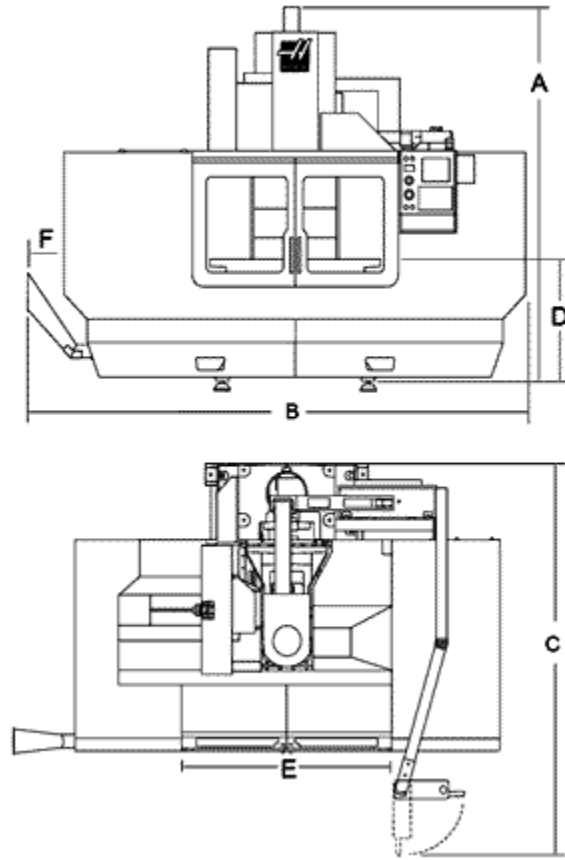

	Mix View	
A	108 "	
B	122 "	
C	107 " (VF-2SS) 122" (VF-2SSYT)	
D	33 "	
E	35 "	
F	22 "	

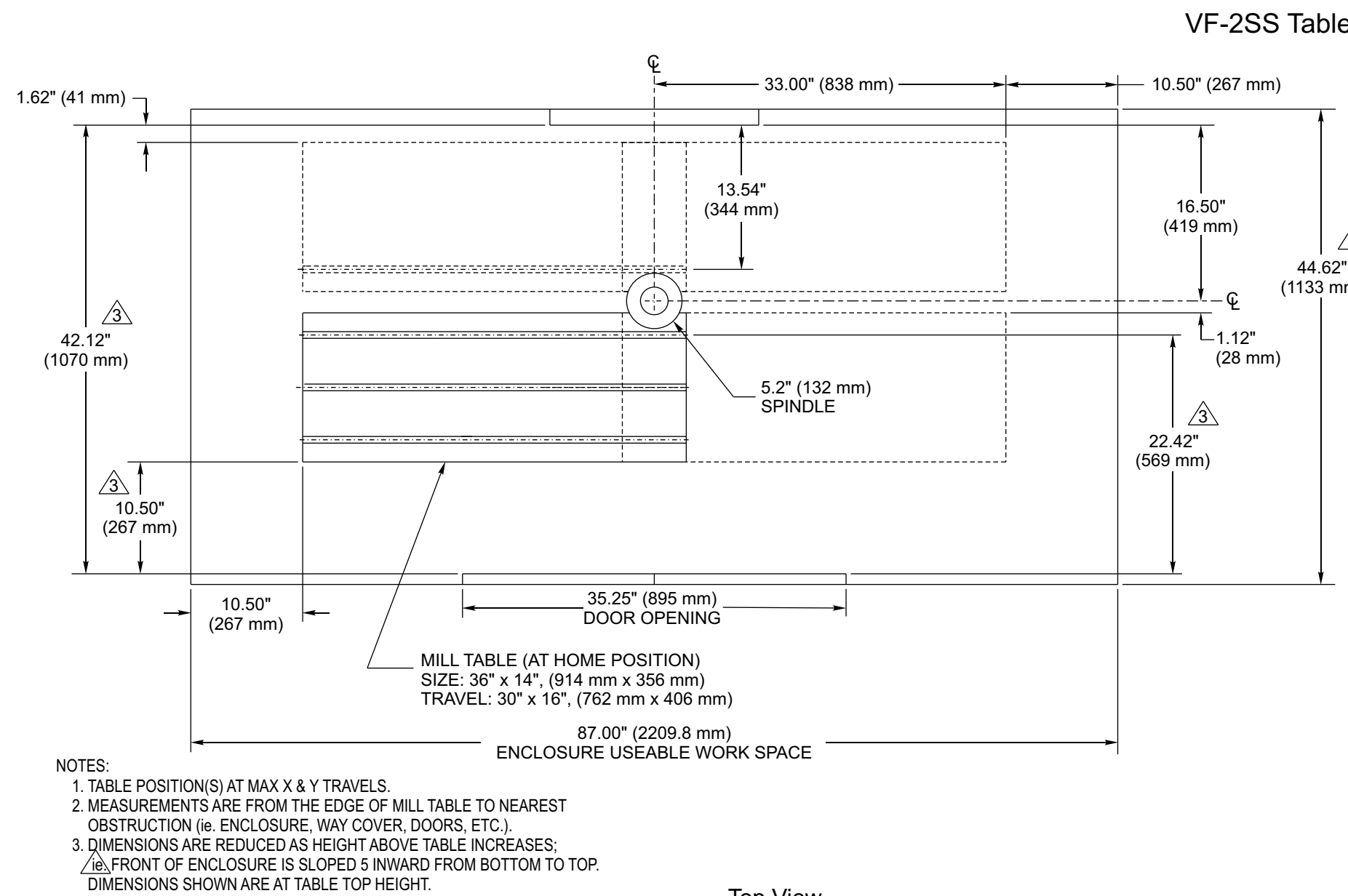
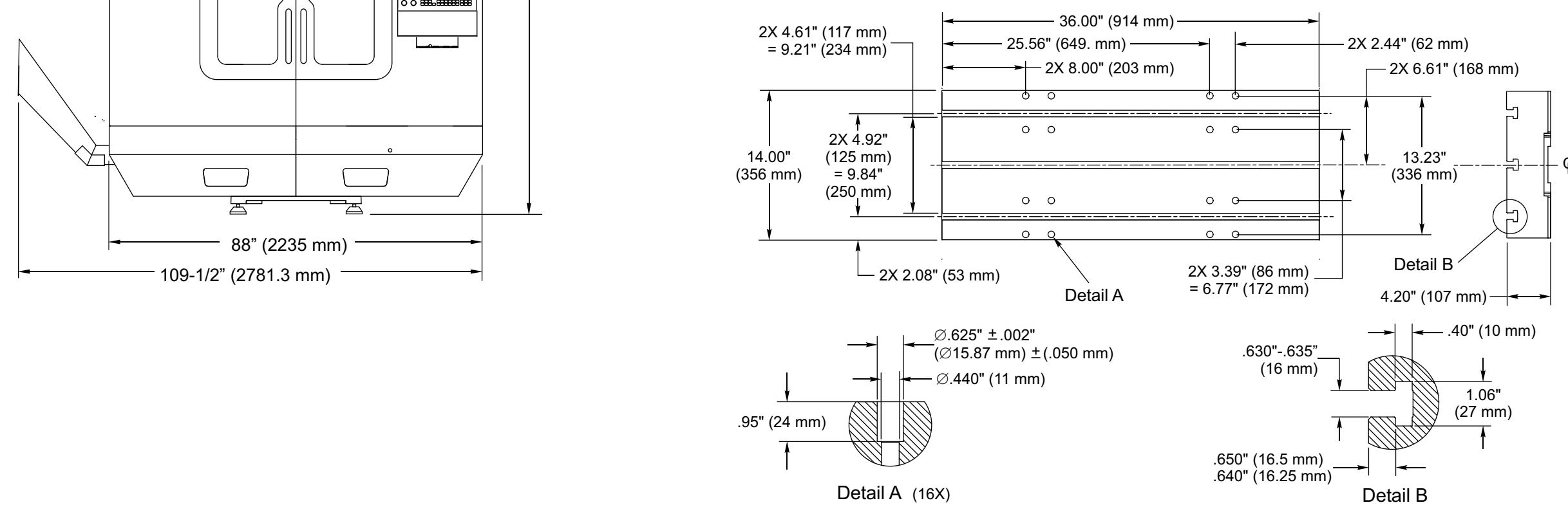
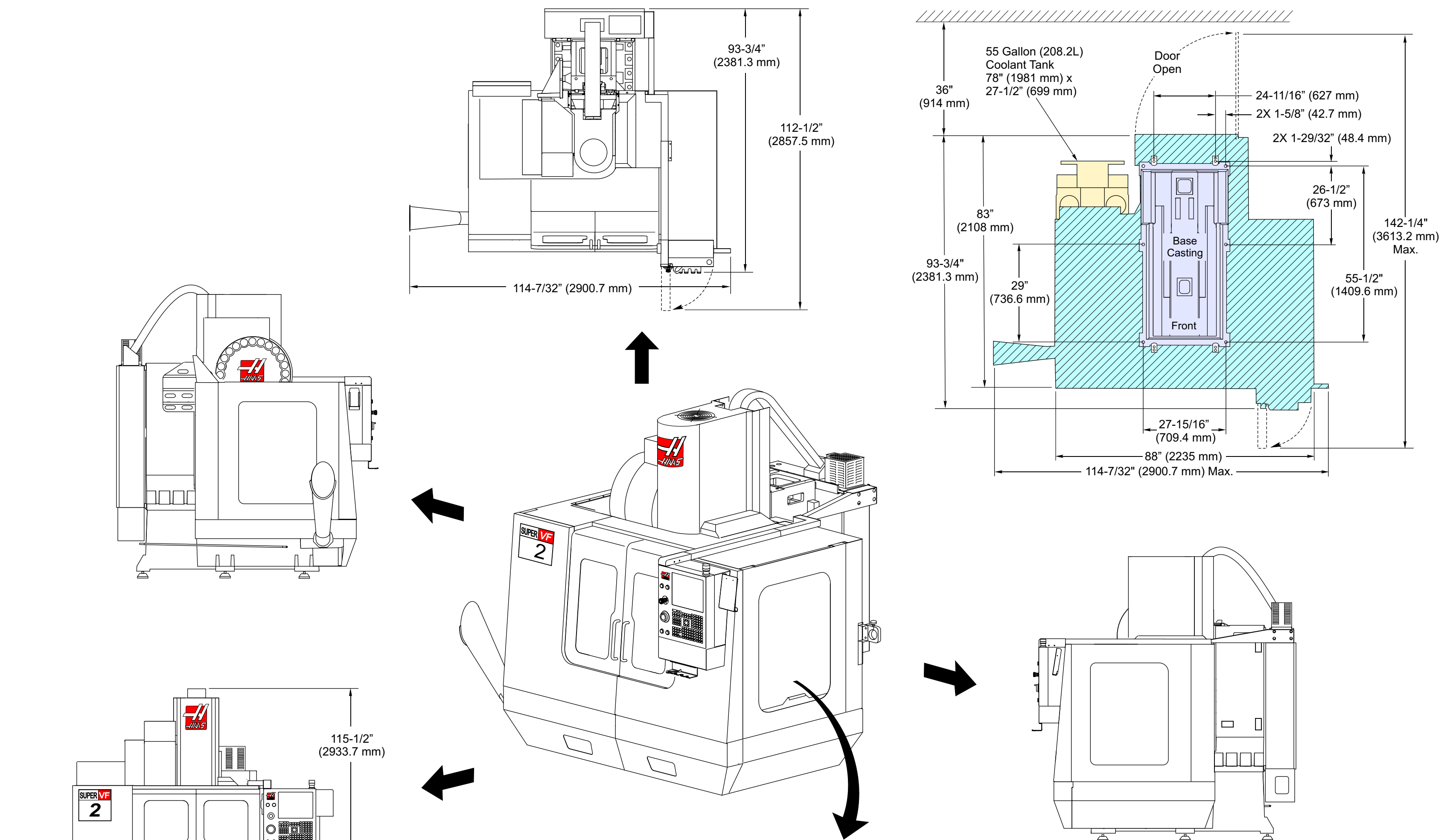

NOTES:
 1. TABLE POSITION(S) AT MAX X & Y TRAVELS.
 2. MEASUREMENTS ARE FROM THE EDGE OF MILL TABLE TO NEAREST OBSTRUCTION (ie. ENCLOSURE, WAY COVER, DOORS, ETC.).
 3. DIMENSIONS ARE REDUCED AS HEIGHT ABOVE TABLE INCREASES.
 4. FRONT OF ENCLOSURE IS SLOPED 5 INWARD FROM BOTTOM TO TOP.
 DIMENSIONS SHOWN ARE AT TABLE TOP HEIGHT.

Top View

VF-2SS Enclosure Work Space

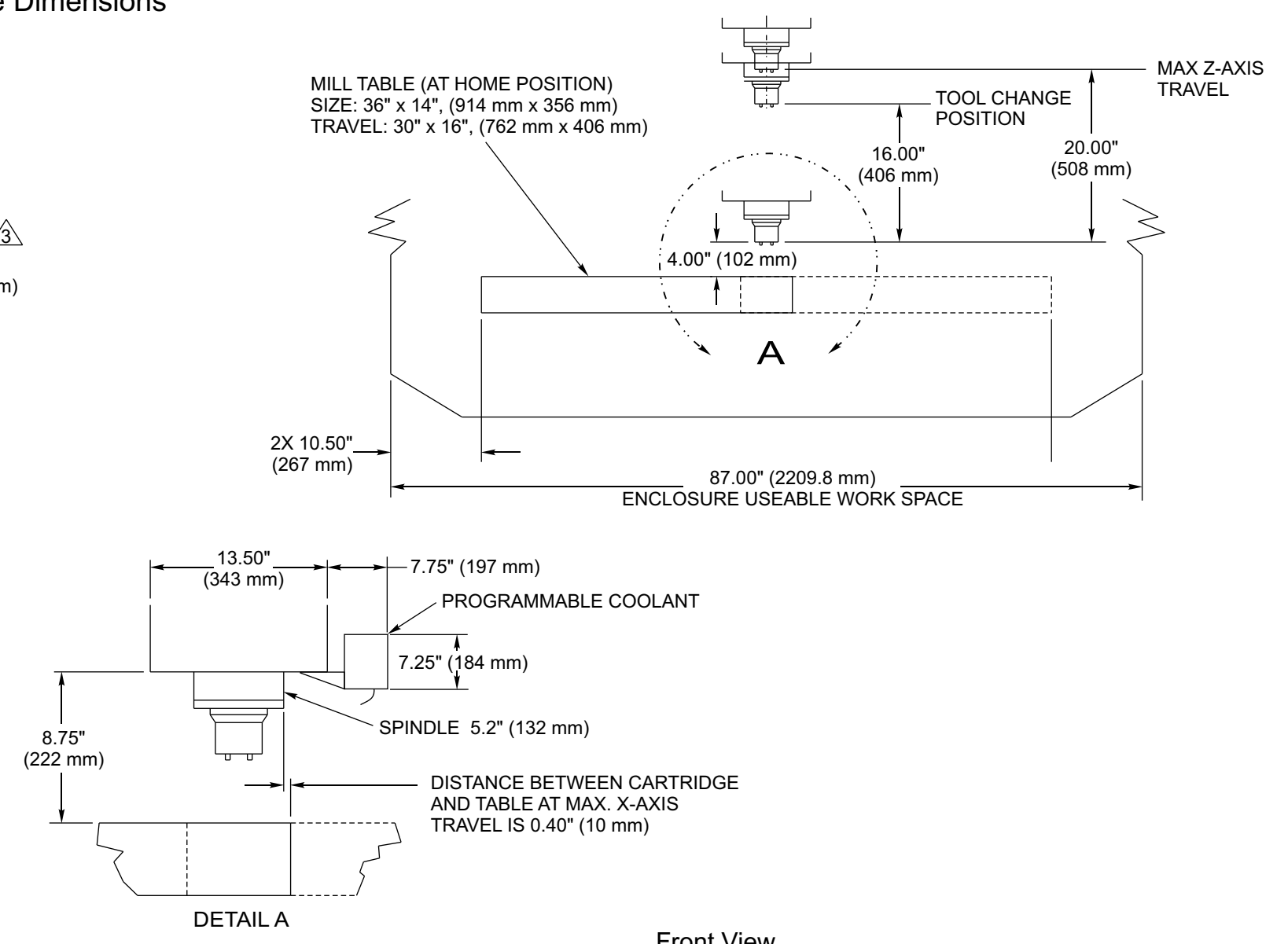

DETAIL A

Front View

