



Productivity Inc®

**Haas VF-11 PRE-INSTALLATION CHECKLIST – Rev 1/2009**

Installation of your new Haas VF-11/40-VF-11/50 can be smooth and rapid if preparations are made prior to the delivery of your machine. Any questions regarding machine installation should be directed to our service department for clarification. We hope this checklist will aid in a rapid installation of your new machine. **Note: The following must be completed prior to our technician arriving to install your new machine.**

- Power Requirements\*\* for your machine: **40T\*\*** 230v/3ph/14kVa 50 Amp (460\*v/3ph/14kVa, 25 Amp)  
**50T** 230v/3ph/28kVa 100 Amp (460\*v/3ph/28kVa, 50 Amp)

Proper voltage per machine specifications should be ready at machine site. **Do NOT power up machine. A separate earth ground wire of the same conductor size as the input power must be connected to the chassis of the machine; must be supplied from the main plant ground. A local cold-water pipe or ground rod is not sufficient. \*460v requires an internal or external transformer.**

\*\*For 40T machines with HT10K option: 230v/3ph/28kVa (100 Amp) 460v/3ph/28kVa (50 Amp)

**\*\*\*NOTE: If you have purchased the 1000 psi High Pressure Coolant option, you will need a separate power source. 208-230v/3ph/20 Amp circuit is needed for the unit. The CNC does NOT provide the power source. Any questions, please contact our Service Department.\*\*\***

- Customer should furnish and have available the proper supply and types of lubricants required for machine operation.

ITEM	Cap (40T)	Cap (50T)	FLUID TYPE
Coolant	95 Gallons	95 Gallons	Water Soluble, synthetic
Way Lube	80 oz	80 oz	Mobil <b>Vactra #2 (40T w/30k, 50T use DTE25)</b>

You will need to have Coolant and lubricants on hand at the time of installation. Contact our Service Department for more information.

- Air lines should be routed to the machine location and operational for proper air pressure.

The VMC requires a minimum of 100 PSI at 4 cfm (40T) or 8 cfm (50T) (w/optional AAG Auto Air Gun, 40-50T, 10 scfm) at the input to the pressure regulator on the back of the machine. This should be supplied by at least a 2-HP compressor, with a minimum 20-gal tank, that turns on when the pressure drops to 100 PSI. The air must be supplied through a minimum 1/2" hose and fittings must be at least 1/4" (40T) or 3/8" (50T) NPT.

- Machine location should be planned to allow enough room for access panels to be opened and serviced with ease. A minimum of 36" is required around the machine for operator and maintenance access.
- Weight requirements should be checked to insure that the surface below the machine will have sufficient strength for support and stability. The machine must be set on a solid, sound and stable, steel bar-reinforced concrete slab poured directly on the grade. In general, the 6" concrete floor on industrial buildings is suitable for machine placement. **The VF-11 must be anchored for proper stabilization of the machine, and comes standard with outriggers on both ends of the machine for support. Anchors must be done prior to the machine's arrival. See Anchoring Instructions – document #ES0095 for instructions and information, found in your Anchor Kit. If you do not have an anchor kit, contact Hope at Productivity, 763-742-1275.**
- **The Haas VF-11 should be moved with a forklift. Notify Hope immediately if you plan to use a crane. Upon arrival of your machine, uncrate and immediately check for visible damage BEFORE the driver leaves.**

SHIPPING WEIGHT	SHIPPING DIMENSIONS ( <i>Skidded/Wrapped on double-drop trailer with O/W Permits</i> )
33,880# (40T)	24' L x 10' W x 10'3" H (40T)
34,760# (50T)	24' L x 10' W x 10'7" H (50T)
<i>See attached for floor space requirements. Operational Weight: 29,400# (40T) 30,900# (50T)</i>	

- Remove as much preservative from the machine as possible without having to power up (tables – slides, pulleys, etc.). We recommend mineral spirits to clean. Apply oil when finished to prevent rust.

## VF-11 Dimensions

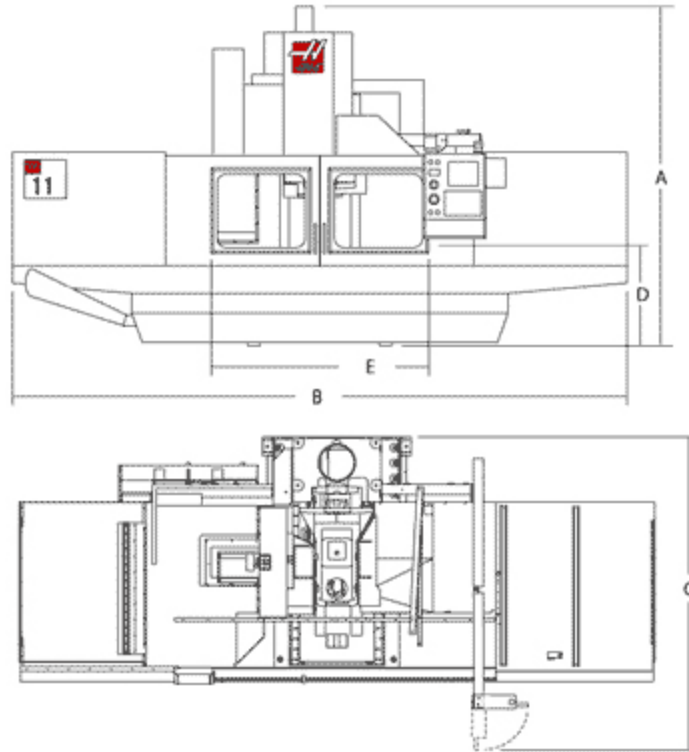

	Mix View	
A	124 " (40T) 138" (50T)	
B	257 "	
C	169 " (40T) 170" (50T)	
D	43 "	
E	121 "	

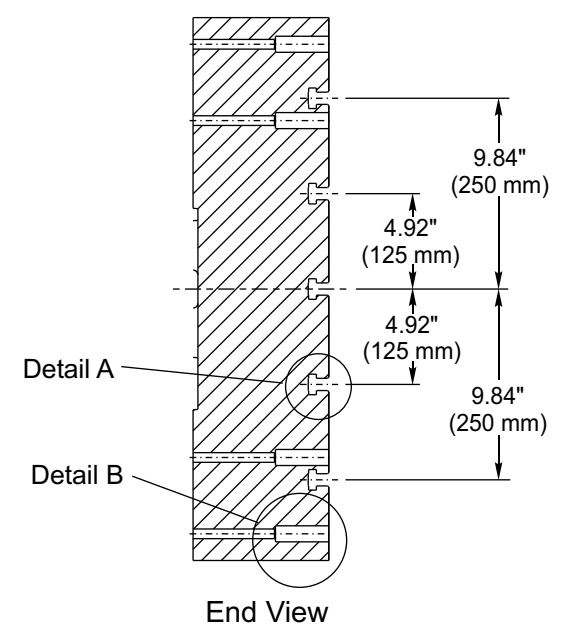
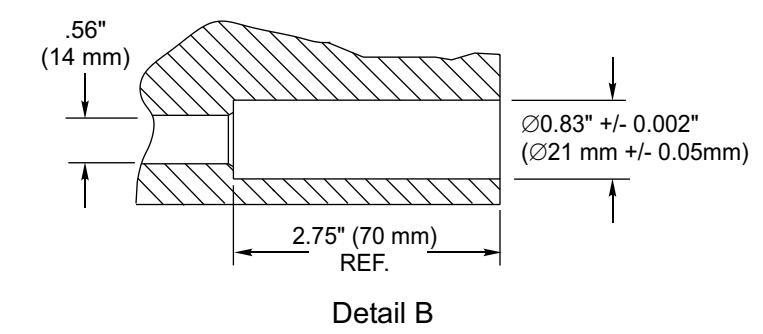
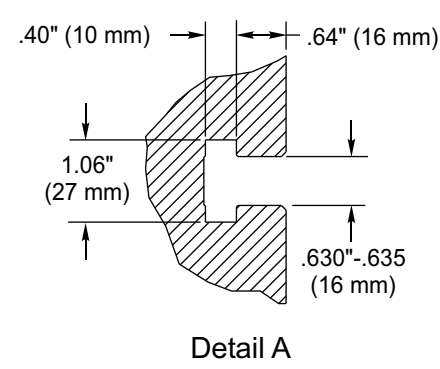
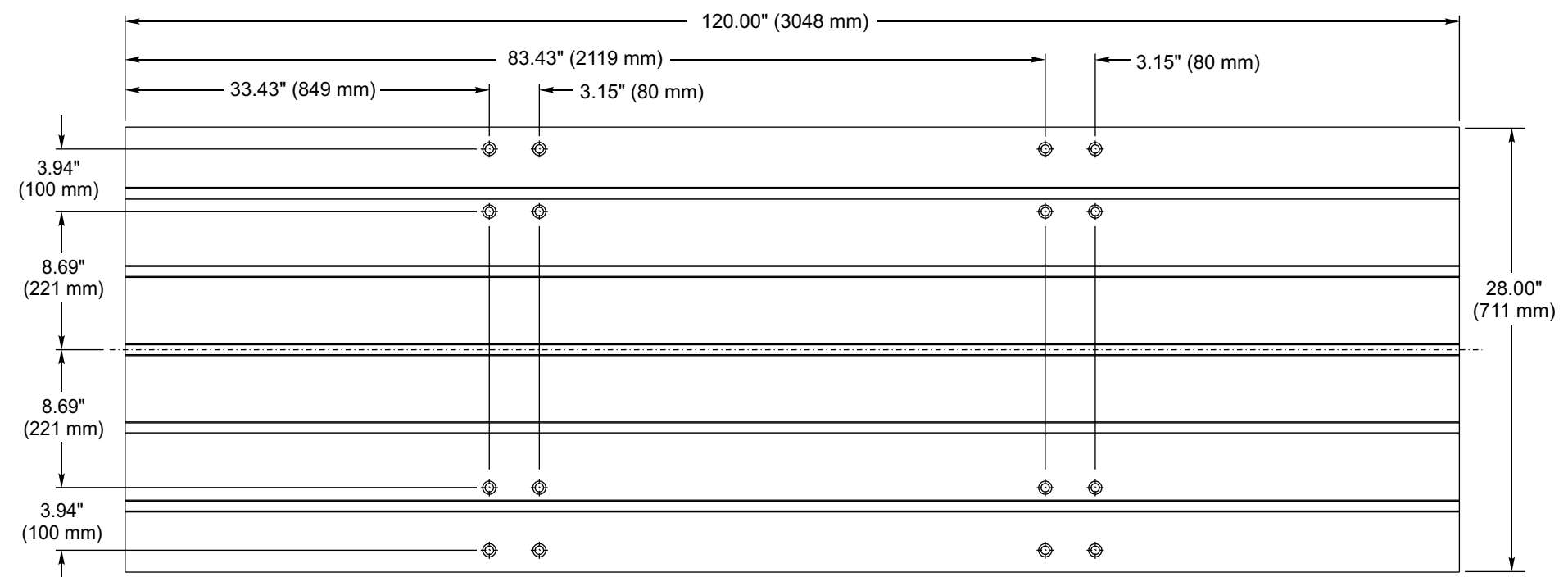
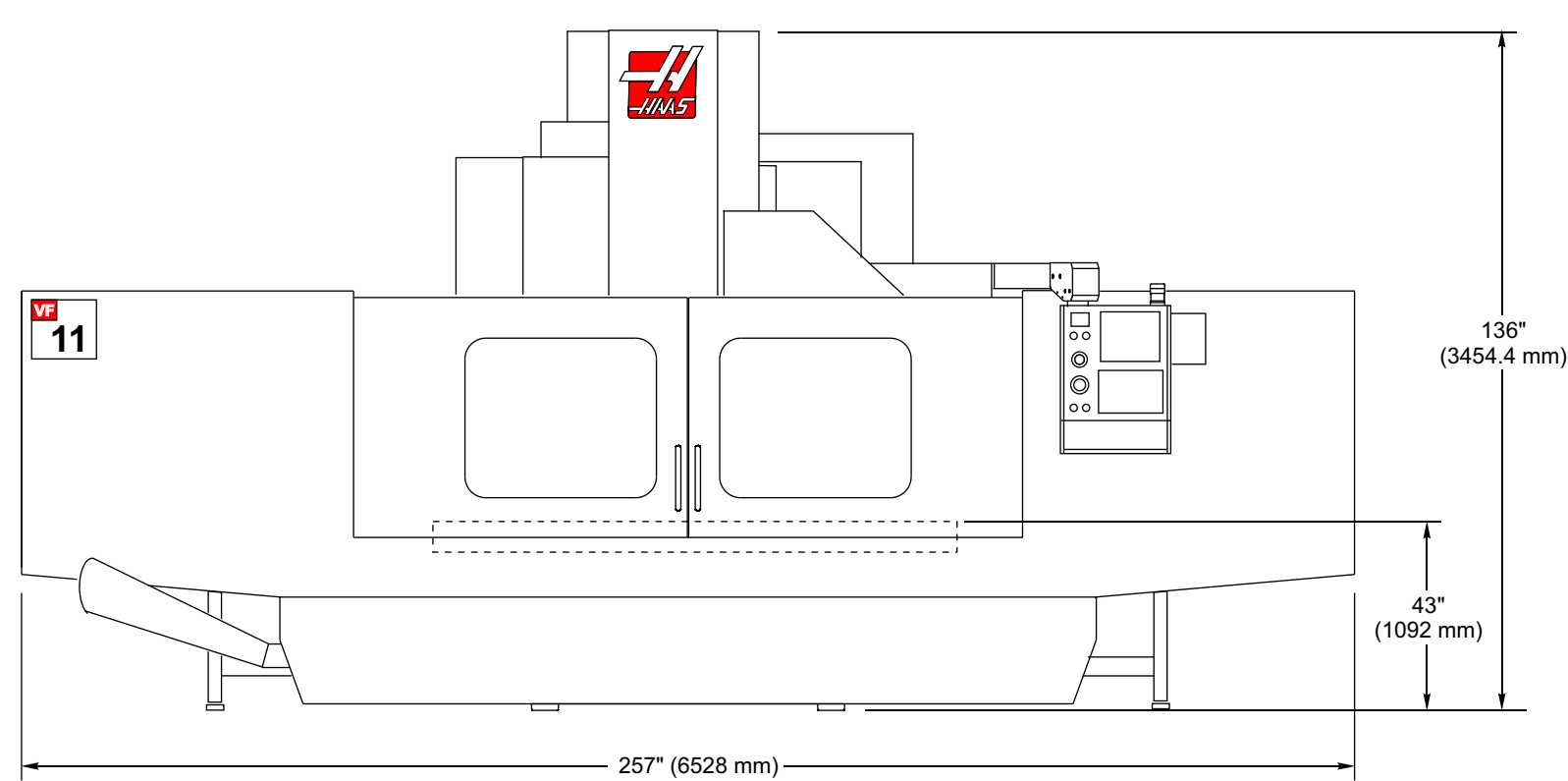
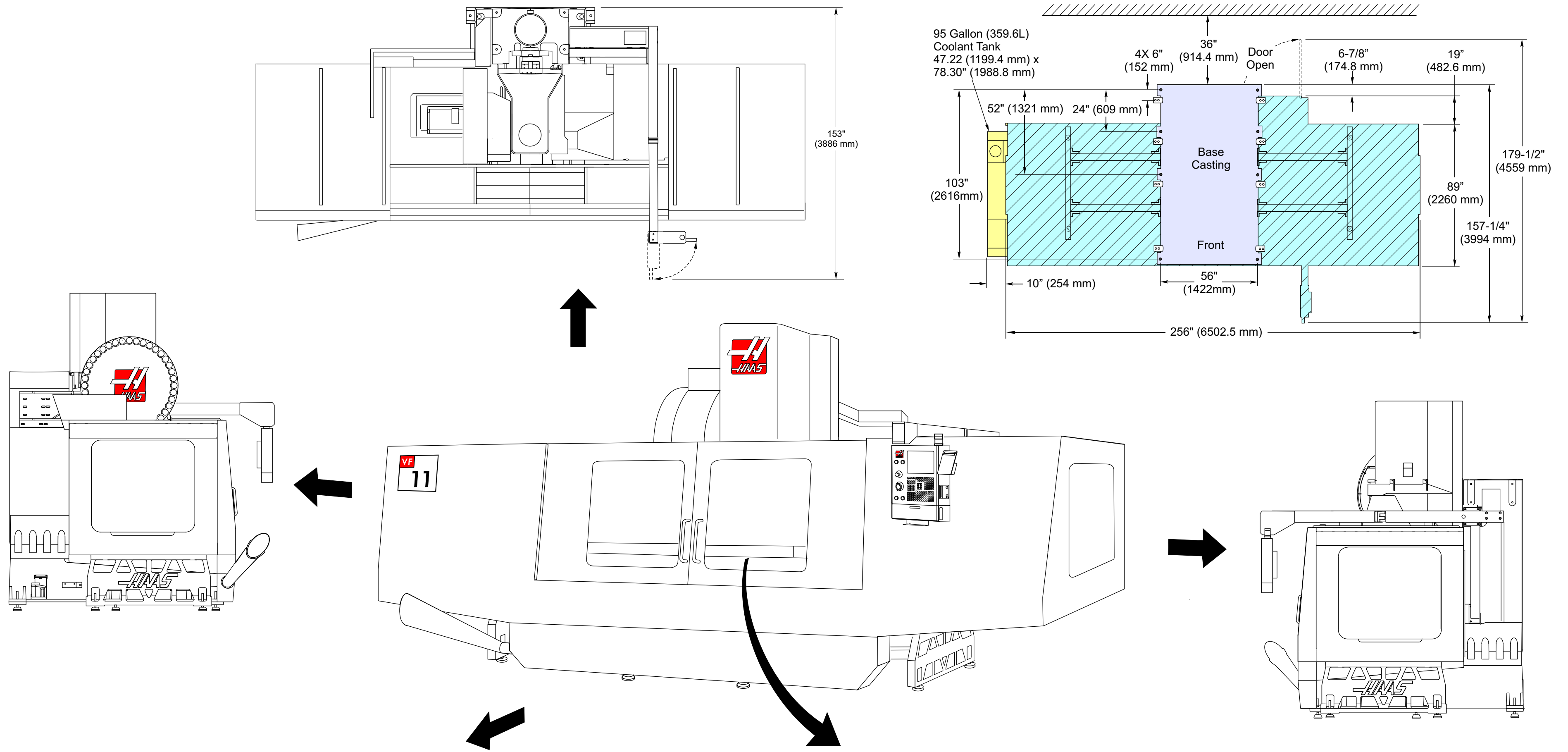

VF-11/40 Table Dimensions

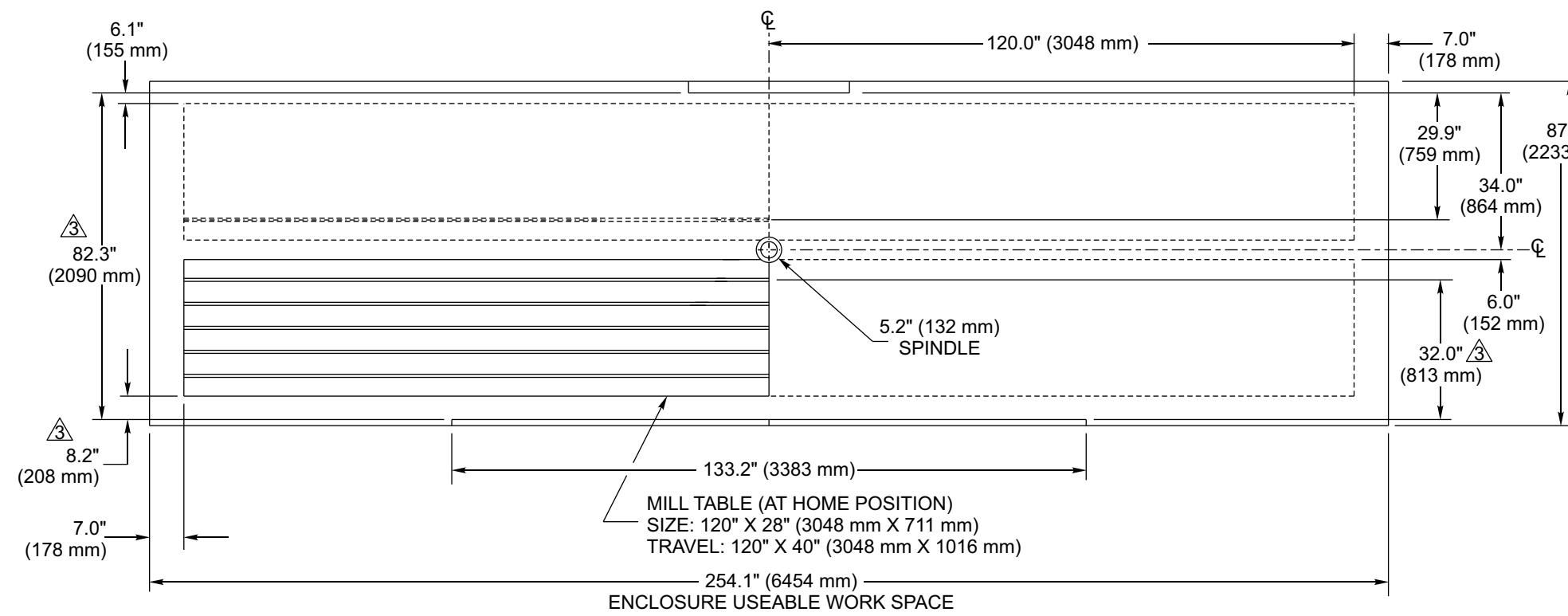

- NOTES:
1. TABLE POSITION(S) AT MAX X & Y TRAVELS.
  2. MEASUREMENTS ARE FROM THE EDGE OF MILL TABLE TO NEAREST OBSTRUCTION (i.e. ENCLOSURE, WAY COVER, DOORS, ETC.).
  3. DIMENSIONS ARE REDUCED AS HEIGHT ABOVE TABLE INCREASES; i.e. FRONT OF ENCLOSURE IS SLOPED 5 INWARD FROM BOTTOM TO TOP. DIMENSIONS SHOWN ARE AT TABLE TOP HEIGHT.

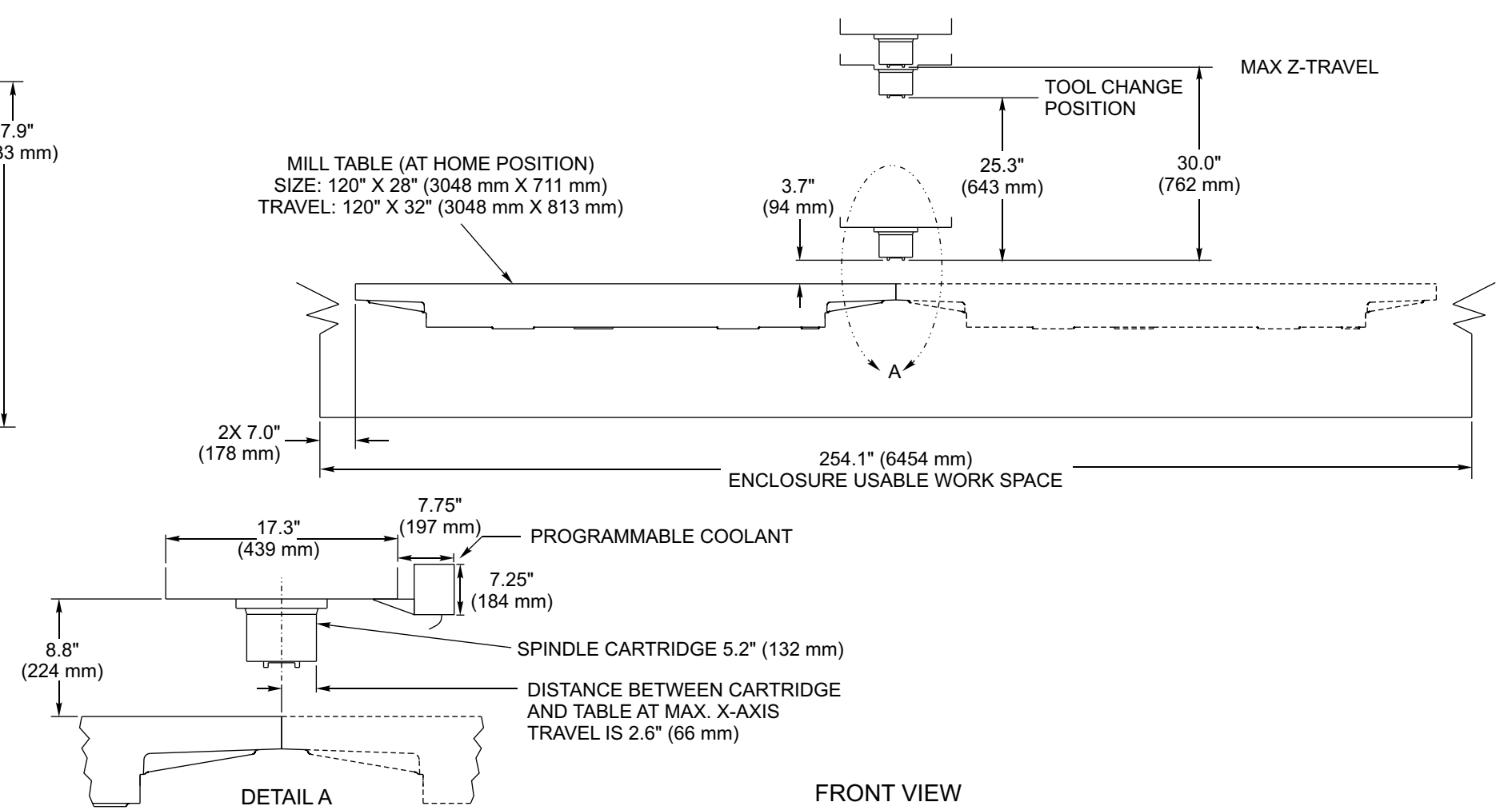

VF-11/40 Enclosure Usable Work Space

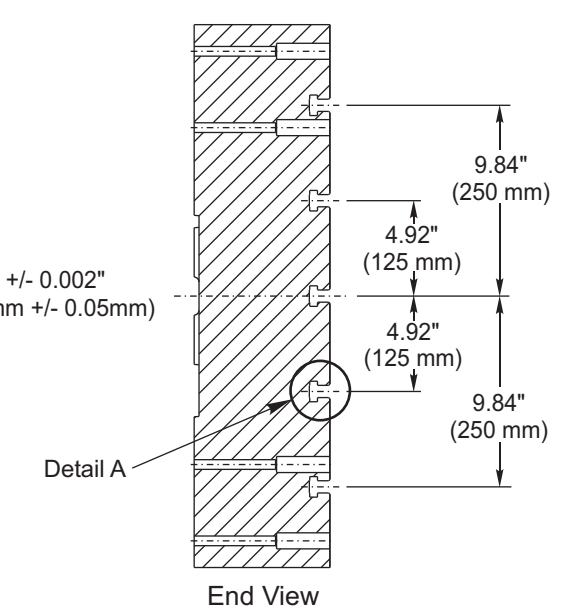
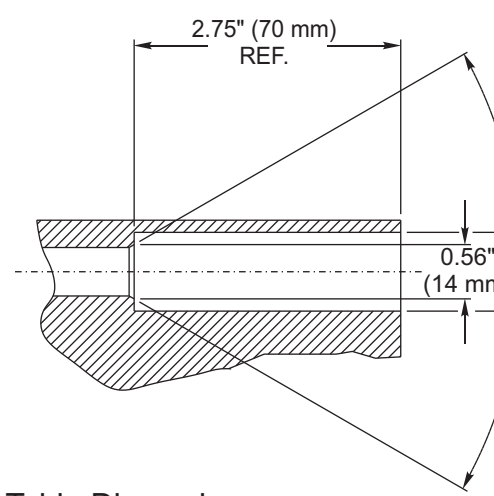
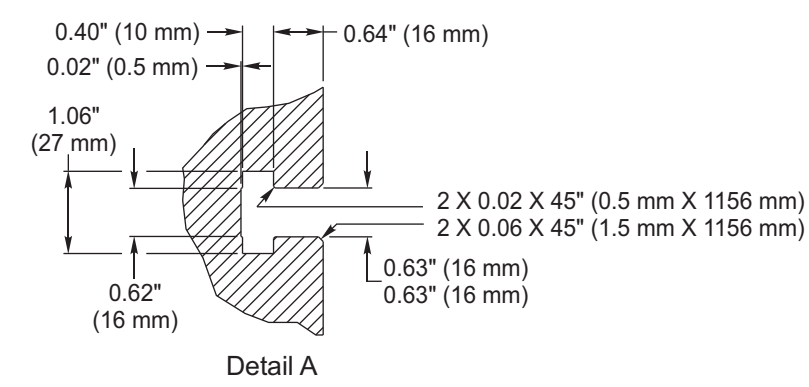
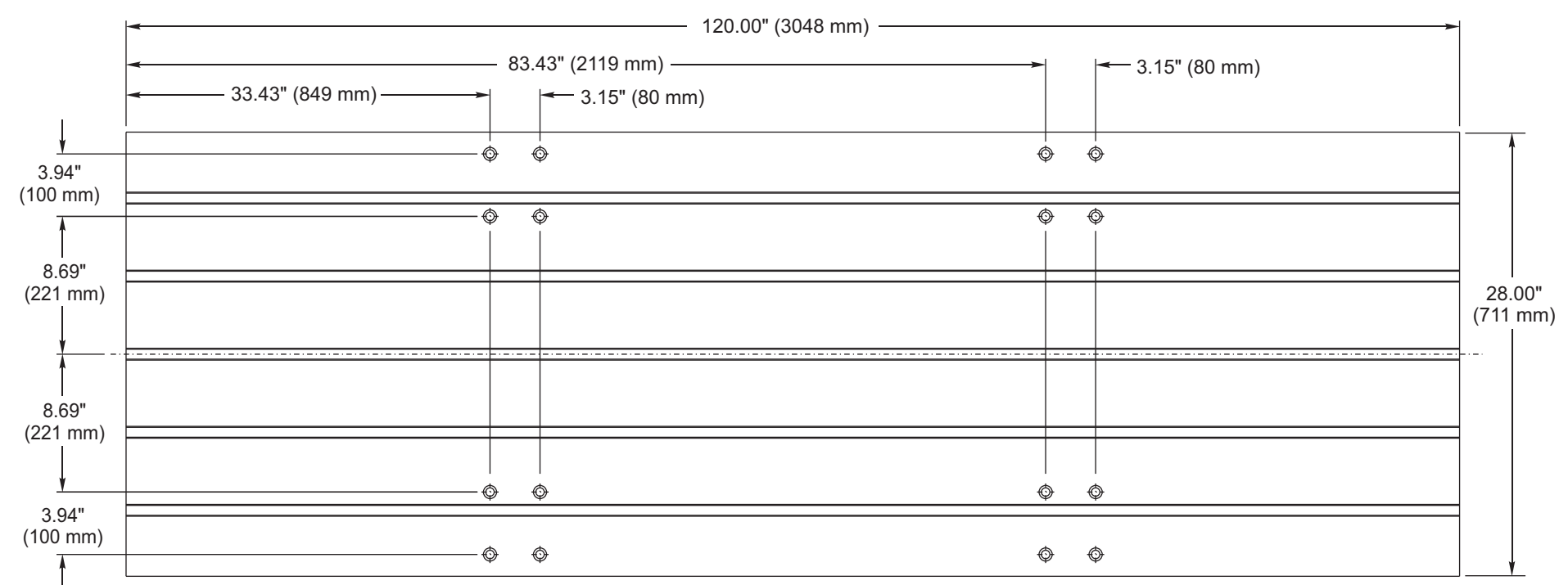
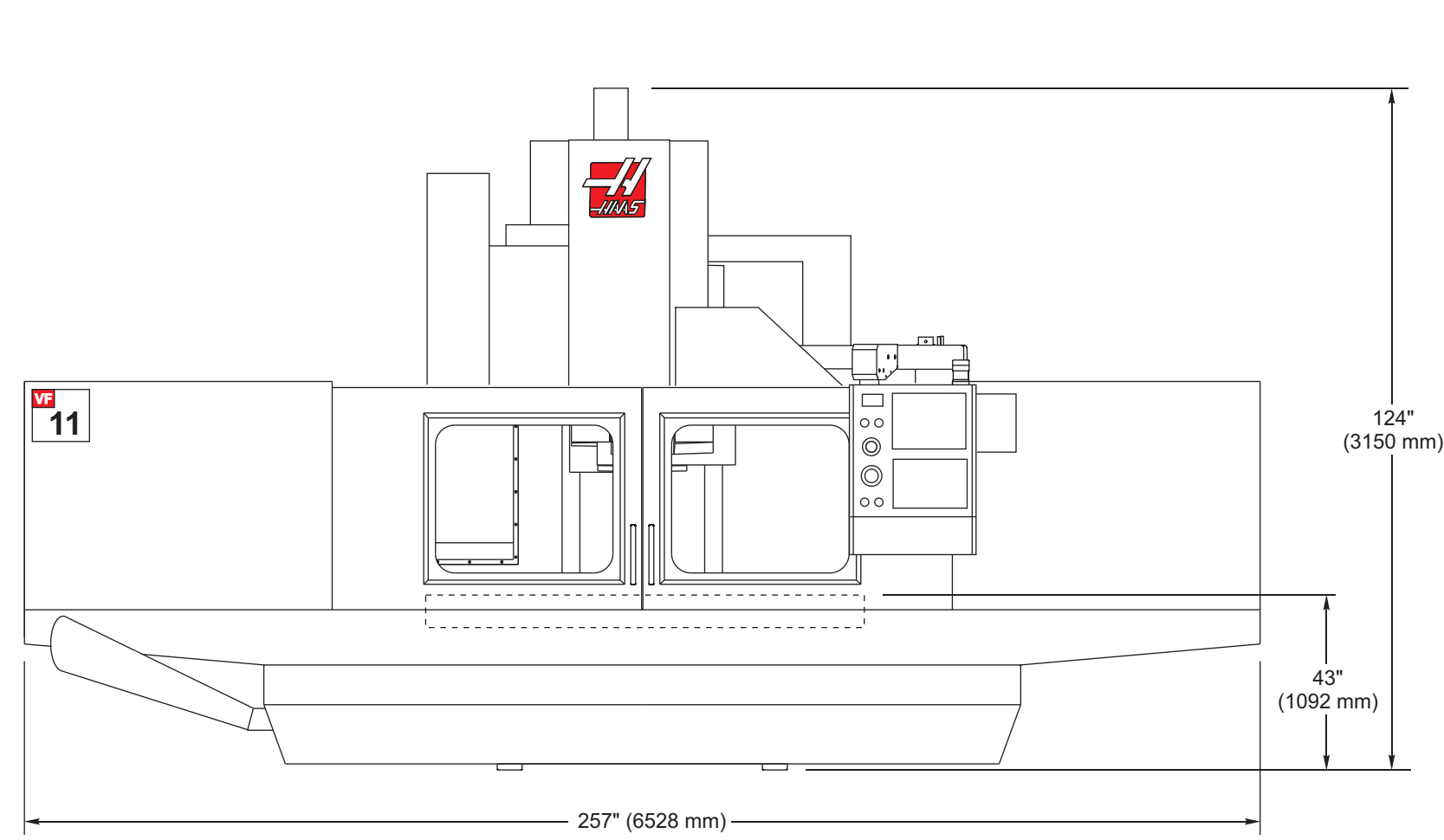
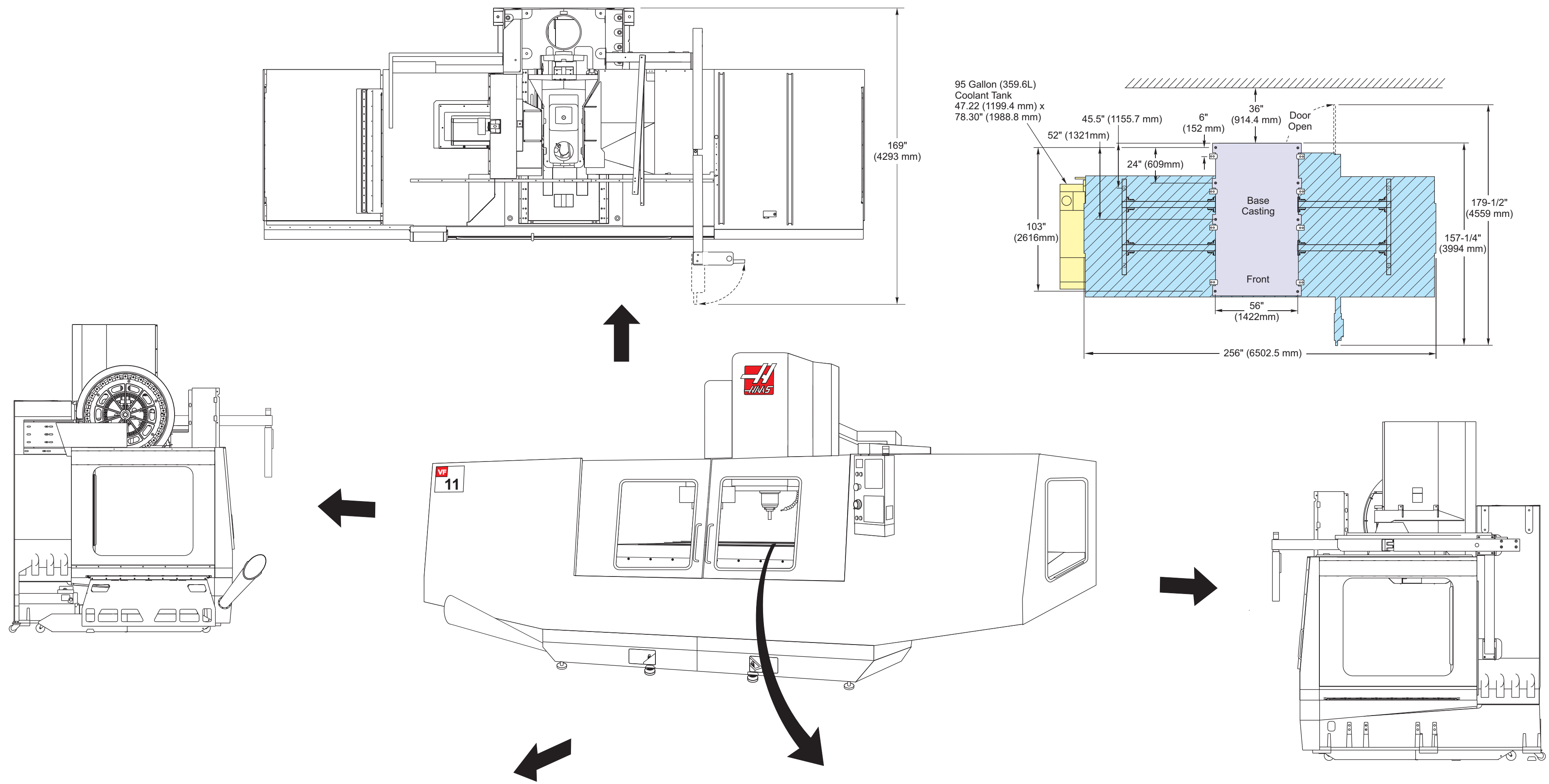

VF11-50 Table Dimensions

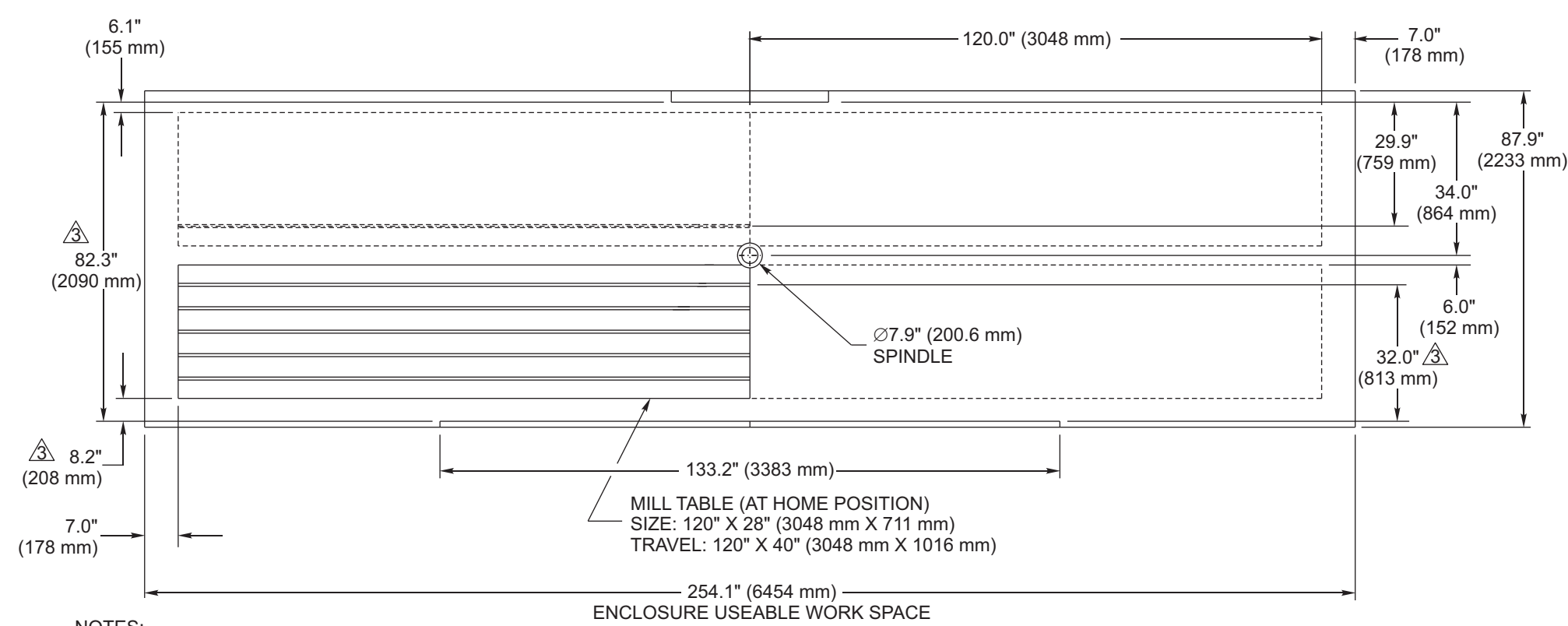

- NOTES:
1. TABLE POSITION(S) AT MAX X & Y TRAVELS.
  2. MEASUREMENTS ARE FROM THE EDGE OF MILL TABLE TO NEAREST OBSTRUCTION (i.e. ENCLOSURE, WAY COVER, DOORS, ETC.).
- △ DIMENSIONS ARE REDUCED AS HEIGHT ABOVE TABLE INCREASES;  
i.e. FRONT OF ENCLOSURE IS SLOPED 5 INWARD FROM BOTTOM TO TOP.  
DIMENSIONS SHOWN ARE AT TABLE TOP HEIGHT.

TOP VIEW

VF11-50 Enclosure Usable Work Space

