



15150 – 25th Avenue North, Minneapolis, MN 55447-1981
 Phone 763-476-8600 Fax 763-476-4092 Visit us at: www.productivity.com
 Service Dept: (MN) 763-476-4191 (IA) 319-632-4288 (NE) 402-330-2323
 Productivity is ISO 9001:2000 Certified

Productivity Inc®

Haas TL-2 PRE-INSTALLATION CHECKLIST - Rev 01/2009

Installation of your new Haas TL-2 can be smooth and rapid if preparations are made prior to the delivery of your machine. Any questions regarding machine installation should be directed to our service department for clarification. We hope this checklist will aid in a rapid installation of your new machine. **NOTE: The following must be completed prior to our service technician arriving to install your new machine.**

- Power Requirements* for your machine: 208v/3-phase or 240v/1-phase, 9 kVa AMPS: 40 (1-ph), 25 (3-ph)
 Proper voltage per machine specifications should be ready at machine site. **Do NOT power up machine. A separate earth ground wire of the same conductor size as the input power must be connected to the chassis of the machine; must be supplied from the main plant ground. A local cold-water pipe or ground rod is not sufficient.**

***If you wish to run off 460v, you will need an External Transformer, 460v/3ph/9kVa, 15 Amps**

- Customer should furnish and have available the proper supply and types of lubricants required for machine operation.

| ITEM | CAPACITY | FLUID TYPE |
|-------------------------------------|-----------|--------------------------|
| Coolant (If CPKTL option purchased) | 5 Gallons | Water soluble, synthetic |
| Grease | As needed | General Purpose Lithium |

NOTE: You will need to have the coolant on hand at time of installation, if you purchase the Coolant Pump option.

- Air lines should be routed to the machine location and operational for proper air pressure.

| |
|-----------------|
| Not Applicable. |
|-----------------|

- Machine location should be planned to allow enough room for access panels to be opened and serviced with ease. **A minimum of 36" clearance around the machine is required for operator/maintenance access.**
- Weight requirements should be checked to insure that the surface below the machine will have sufficient strength for support and stability. The machine must be set on a solid, sound and stable, steel bar-reinforced concrete slab poured directly on the grade. In general, the 6" concrete floor on industrial buildings is suitable for machine placement.
- **The Toolroom Mill must be moved with a forklift. It CANNOT be craned. Upon arrival of your machine, uncrate and immediately check for visible damage.**

| SHIPPING WEIGHT | SHIPPING DIMENSIONS OF MACHINE |
|---|--------------------------------|
| 5,040 # (skidded) | 9' L x 5' W x 7'6" H (on skid) |
| <i>Operational Dimensions: 4,000# See attached for Floor Space Requirements/Layout. (Remember to leave 36" around the machine for operator/maintenance access.)</i> | |

- **Remove as much preservative from the machine as possible without having to power up (tables – slides, pulleys, etc.). We recommend mineral spirits to clean. Apply oil when finished to prevent rust.**

PLEASE FORWARD THIS TO THE APPROPRIATE PERSON. THANK YOU.

TL-2 Layout/Dimensions

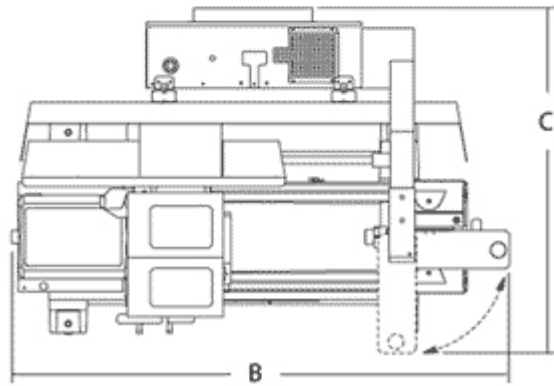
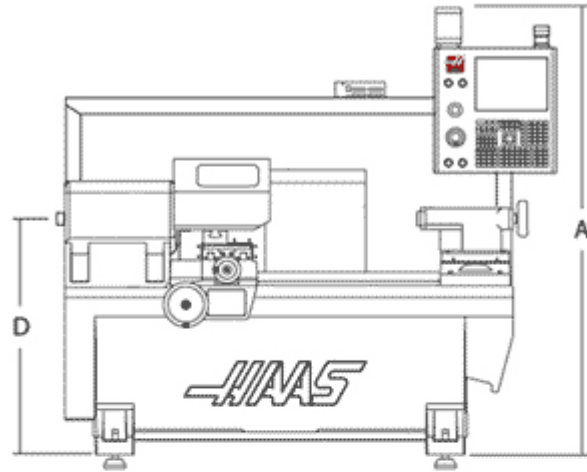

| | Mix View | |
|---|----------|--|
| A | 75 " | |
| B | 99 " | |
| C | 55 " | |
| D | 41 " | |

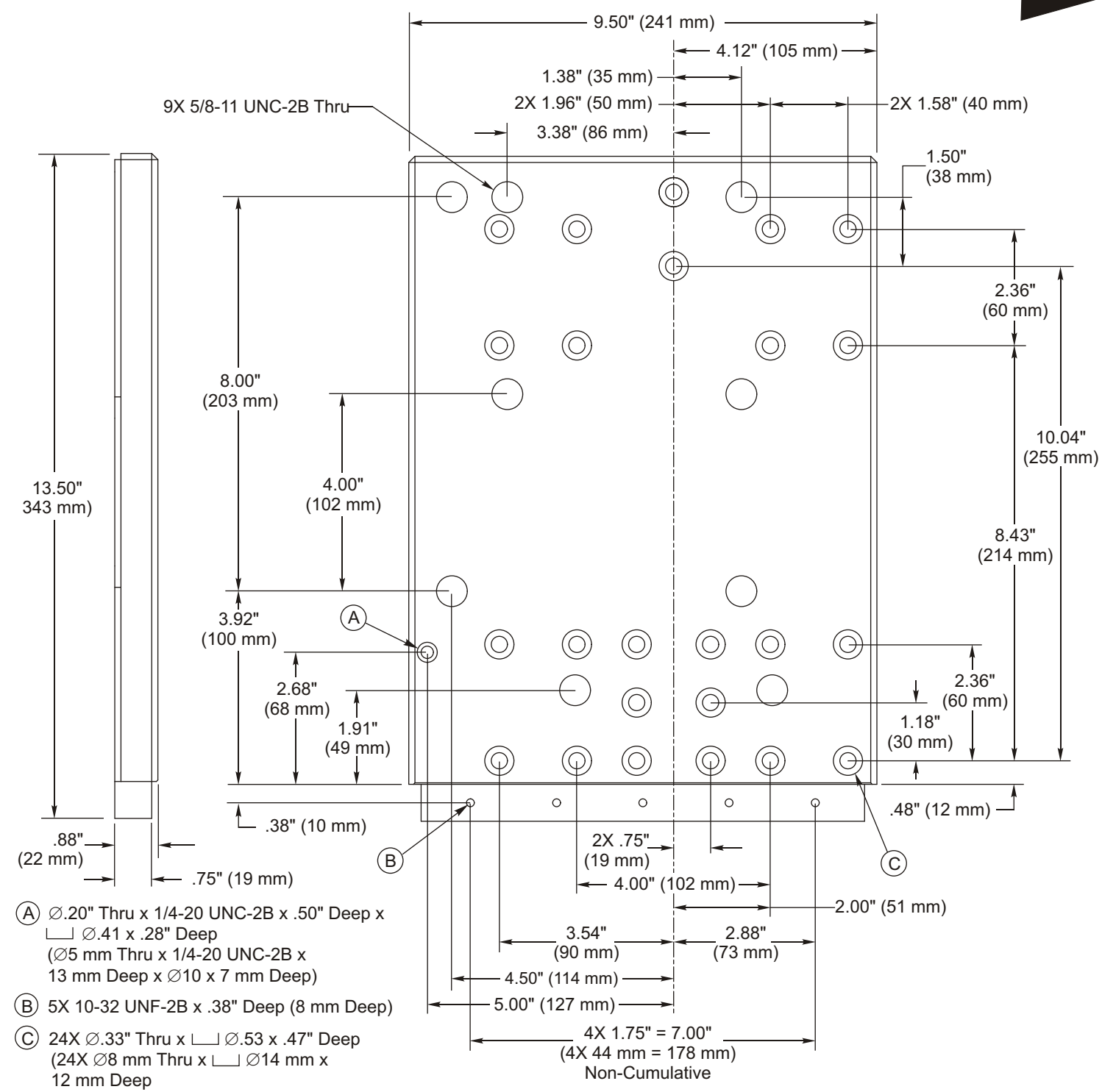
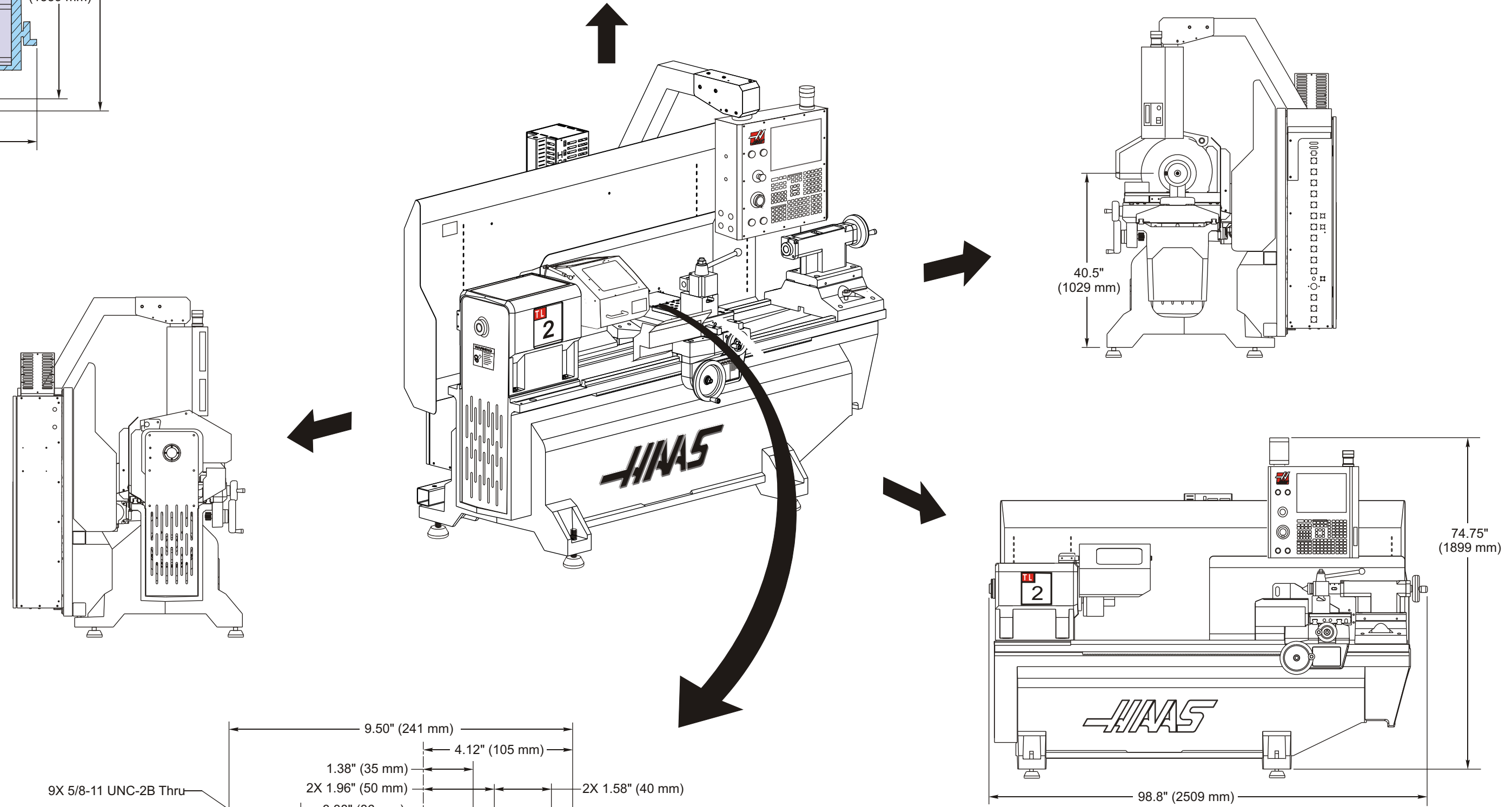
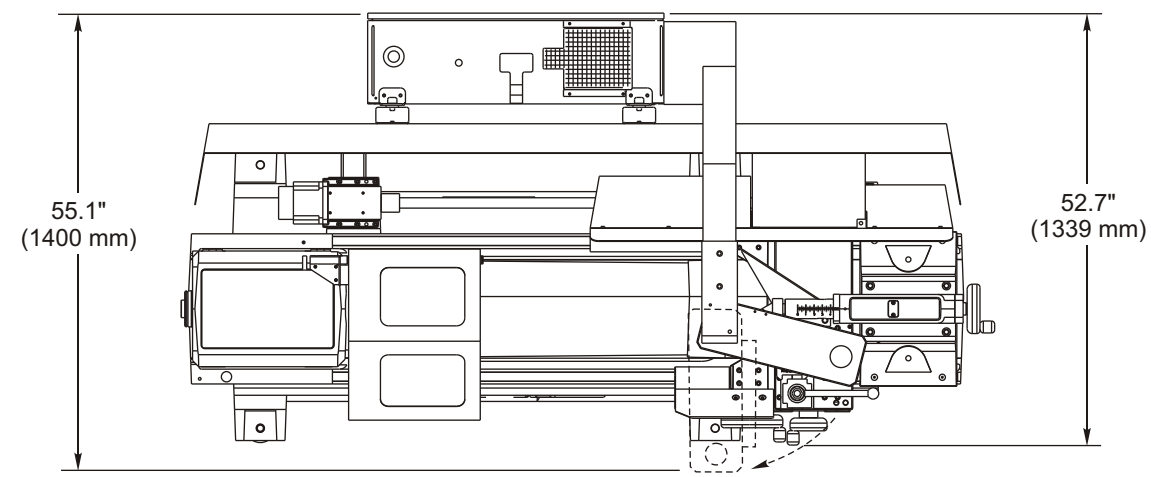
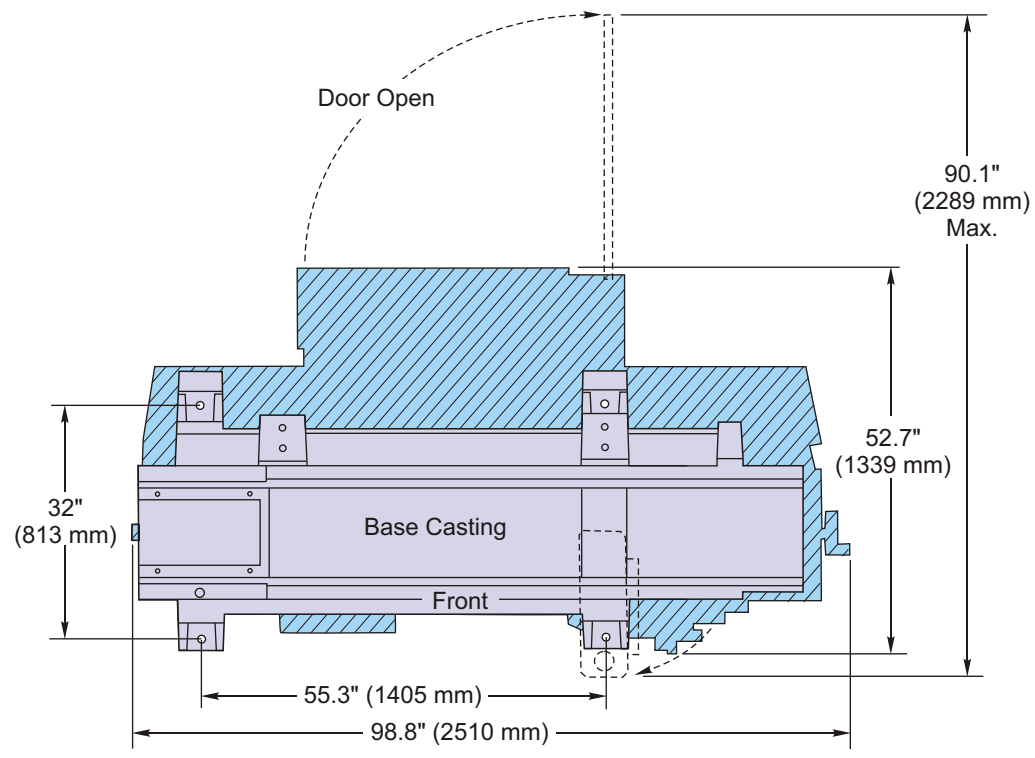

- (A) $\varnothing .20$ " Thru x $1/4$ -20 UNC-2B x .50" Deep x $\varnothing .41$ x .28" Deep
($\varnothing 5$ mm Thru x $1/4$ -20 UNC-2B x 13 mm Deep x $\varnothing 10$ x 7 mm Deep)
- (B) 5X 10-32 UNF-2B x .38" Deep (8 mm Deep)
- (C) 24X $\varnothing .33$ " Thru x $\varnothing .53$ x .47" Deep
(24X $\varnothing 8$ mm Thru x $\varnothing 14$ mm x 12 mm Deep)

TL-2 Cross Slide Dimensions

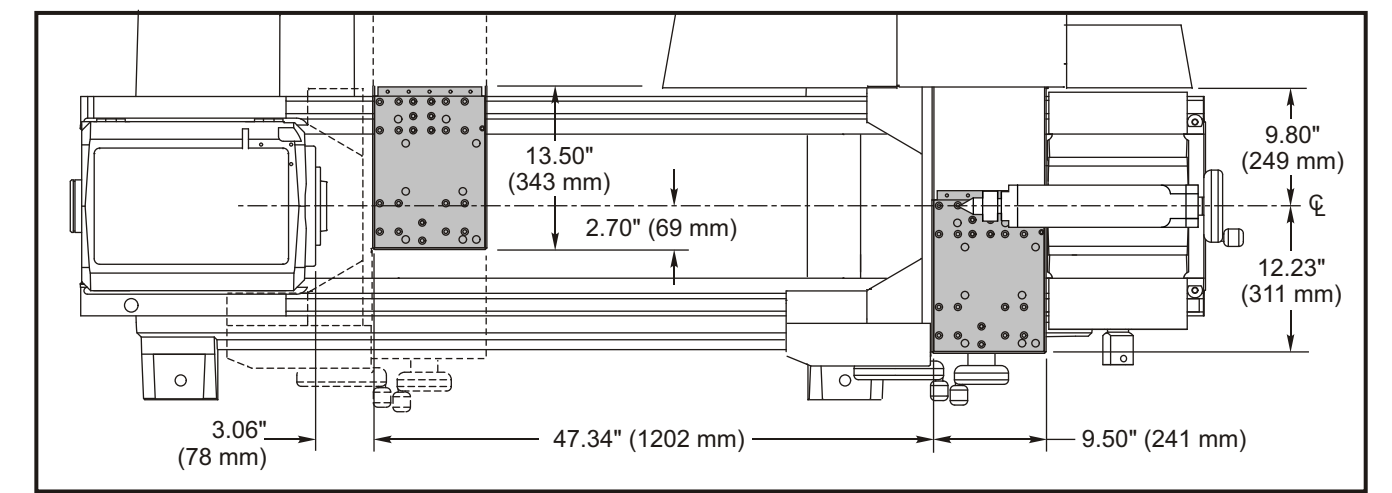
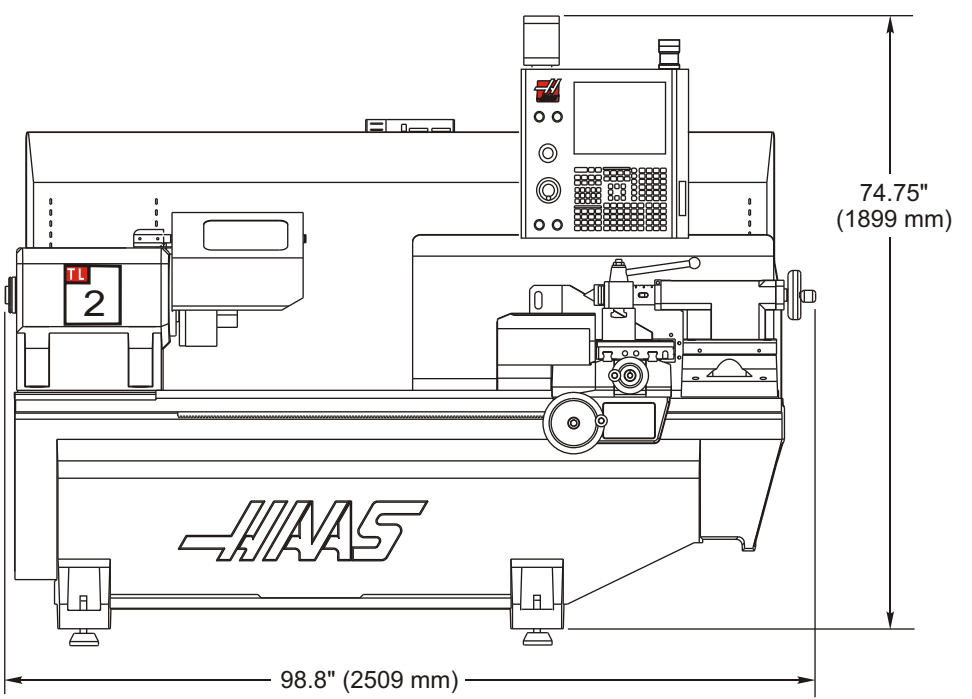

TL-2 Enclosure Work Space (Top View)

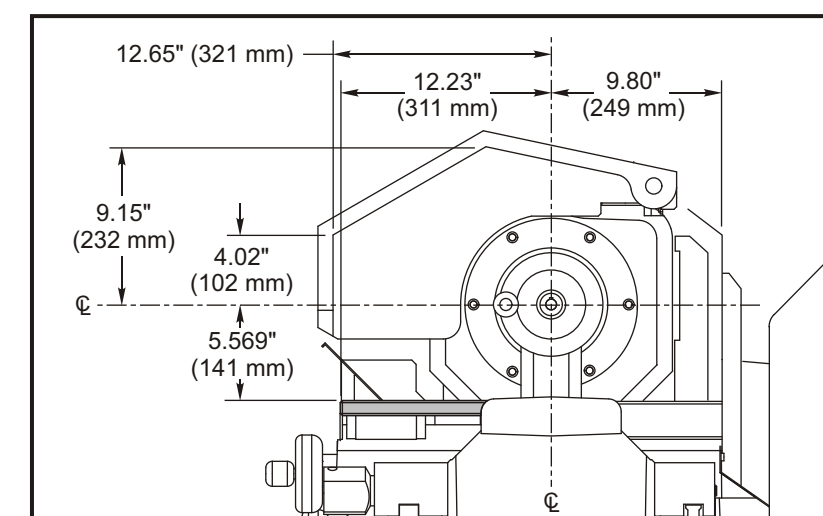

TL-2 Enclosure Work Space (Right Side)