



15150 25th Avenue North, Minneapolis, MN 55447-1981
 Phone 763-476-8600 Fax 763-476-4092
 Service Dept: MN-763-476-4191 IA-319-632-4288 NE-402-330-2323
 Visit us at: www.productivity.com Productivity is ISO 9001:2000 Certified

Productivity Inc®

Haas TL-15 PRE-INSTALLATION CHECKLIST – Rev 1/2009

Installation of your new Haas TL15 can be smooth and rapid if preparations are made prior to the delivery of your machine. Any questions regarding machine installation should be directed to our service department for clarification. We hope this checklist will aid in a rapid installation of your new machine. **NOTE: The following must be completed prior to our service technician arriving at your facility.**

- Power Requirements for your machine: (Std/7K 20HP) 230v/3ph/14kVa 50 Amps (*460v/3ph/14kVa 25 Amps) ****NOTE: For 5K (30HP) option requires 230v/3ph/28kVa, 100 Amp (*460v/3ph/28kVa, 50 Amps)**
 Proper voltage per machine specifications should be ready/wired to the machine. **Do NOT power up machine. A separate earth ground wire of the same conductor size as the input power must be connected to the chassis of the machine; must be supplied from the main plant ground. A local cold-water pipe or ground rod is not sufficient.** *460v requires an External Transformer.
NOTE IF PURCHASING Optional 1000 PSI High Pressure Coolant - You will need a separate power source. 208-230v/3ph/20 Amp circuit needed for the unit. The CNC does NOT provide the power source. Any questions, please contact our service department.

- Customer should furnish and have available the proper supply and types of lubricants required for machine operation.

ITEM	CAPACITY	FLUID TYPE
Coolant	40 gallons	Water Soluble, synthetic, or cutting oil
Way Lube	80 Oz	Mobil Vactra #2

You will need to have Coolant and lubricants on hand at the time of installation. Contact our Service Department for more information.

- Air lines should be routed to the machine location and operational for proper air pressure.

The Lathe requires a minimum of 100 PSI at 4 cfm at the input to the pressure regulator on the back of the machine. This should be supplied by at least a 2-HP compressor, with a minimum 20-gal tank, that turns on when the pressure drops to 100 PSI. The air must be supplied through a minimum 3/8" hose and fittings must be at least 1/4" NPT.

- Machine location should be planned to allow enough room for access panels to be opened and serviced with ease. **A minimum clearance of 36" is required around the machine. (*Dimension below includes this space.)**
- Weight requirements should be checked to insure that the surface below the machine will have sufficient strength for support and stability. The machine must be set on a solid, sound and stable, steel bar-reinforced concrete slab poured directly on the grade. In general, the 6" concrete floor on industrial buildings is suitable for machine placement.
- **NOTE: THE HAAS LATHE CANNOT BE CRANED WITHOUT PURCHASING THE LIFTING KIT, INSTALLED AT THE FACTORY AT TIME OF MANUFACTURE, OR IT MUST BE LIFTED WITH FORKLIFT. CONTACT YOUR SALESPERSON OR LOCAL SERVICE DEPARTMENT FOR MORE INFORMATION.** Upon arrival of your machine, **unpack and immediately check for visible damage.**

SHIPPING WEIGHT	SHIPPING DIMENSIONS OF MACHINE
9,640 # (Machine skidded)	12' L x 8'2" W x 7'7" H (Lathe, skidded and packed)
2,085# (Optional Servo BAR)	8'6" L x 6' W x 5' H (Optional Haas Servo Bar, skidded and packed)
<i>Operational Dimensions: See attached for floor space requirements/operational dimensions for machine and optional BARxxxx. Weight 9,000#</i>	

- Remove as much preservative from the machine as possible without having to power up (tables – slides, pulleys, etc.). We recommend mineral spirits to clean. Apply oil when finished to prevent rust.

PLEASE FORWARD THIS TO THE APPROPRIATE PERSON. THANK YOU.

TL-15 Dimensions

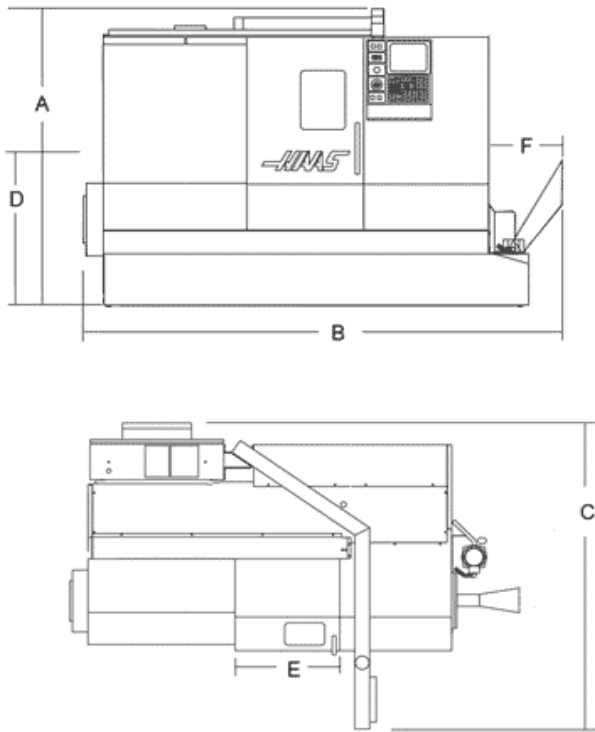

		Mix View
A	72 "	
B	129 "	
C	88 "	
D	37 "	
E	23 "	
F	17 "	

Optional Haas Servo BAR Dimensions/Footprint

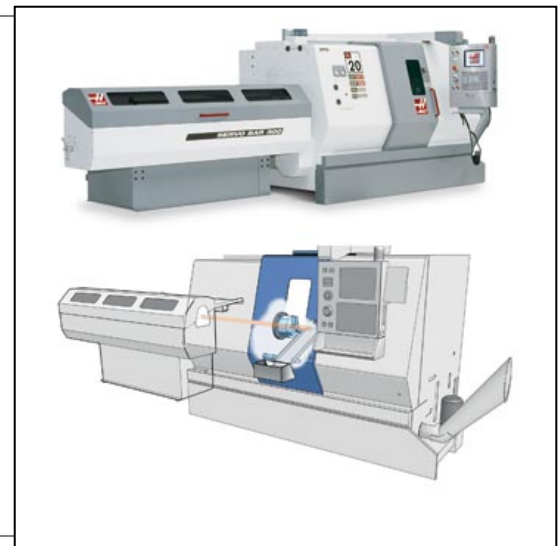
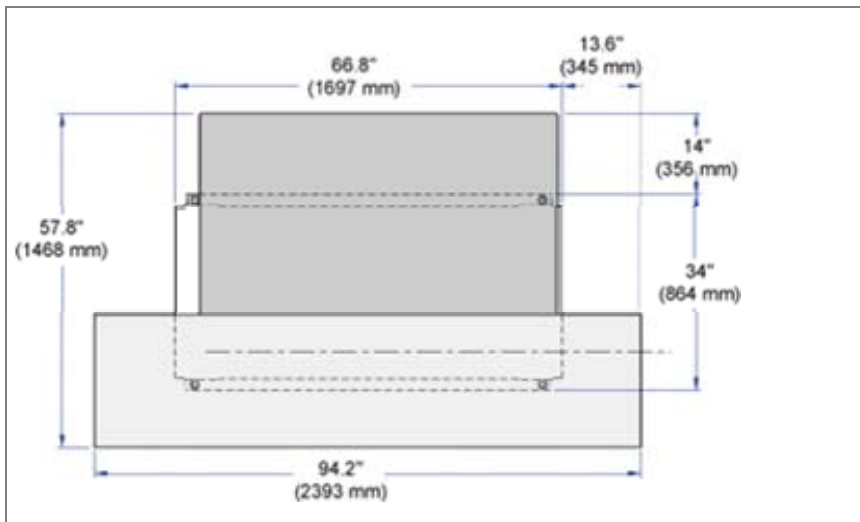

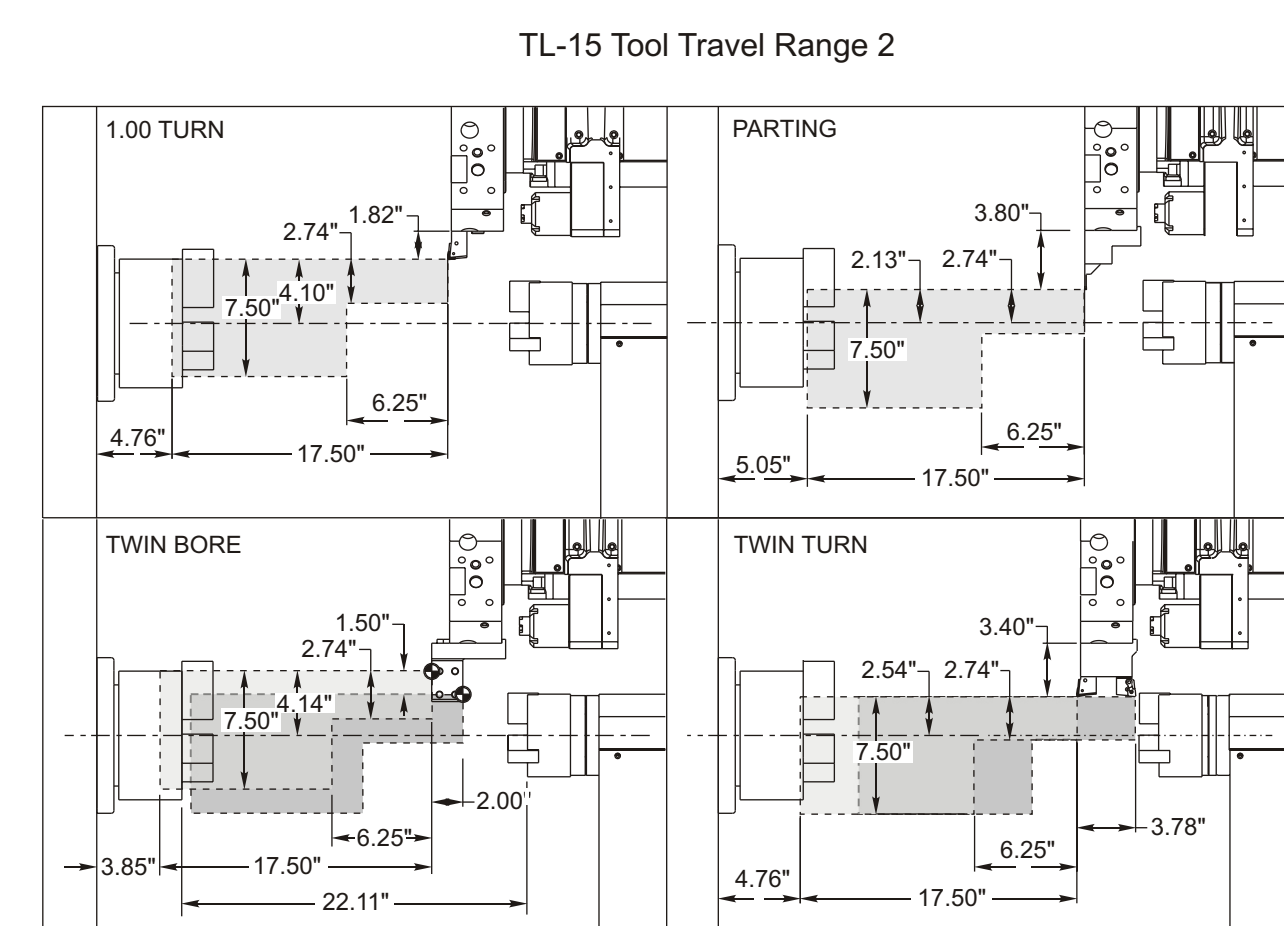
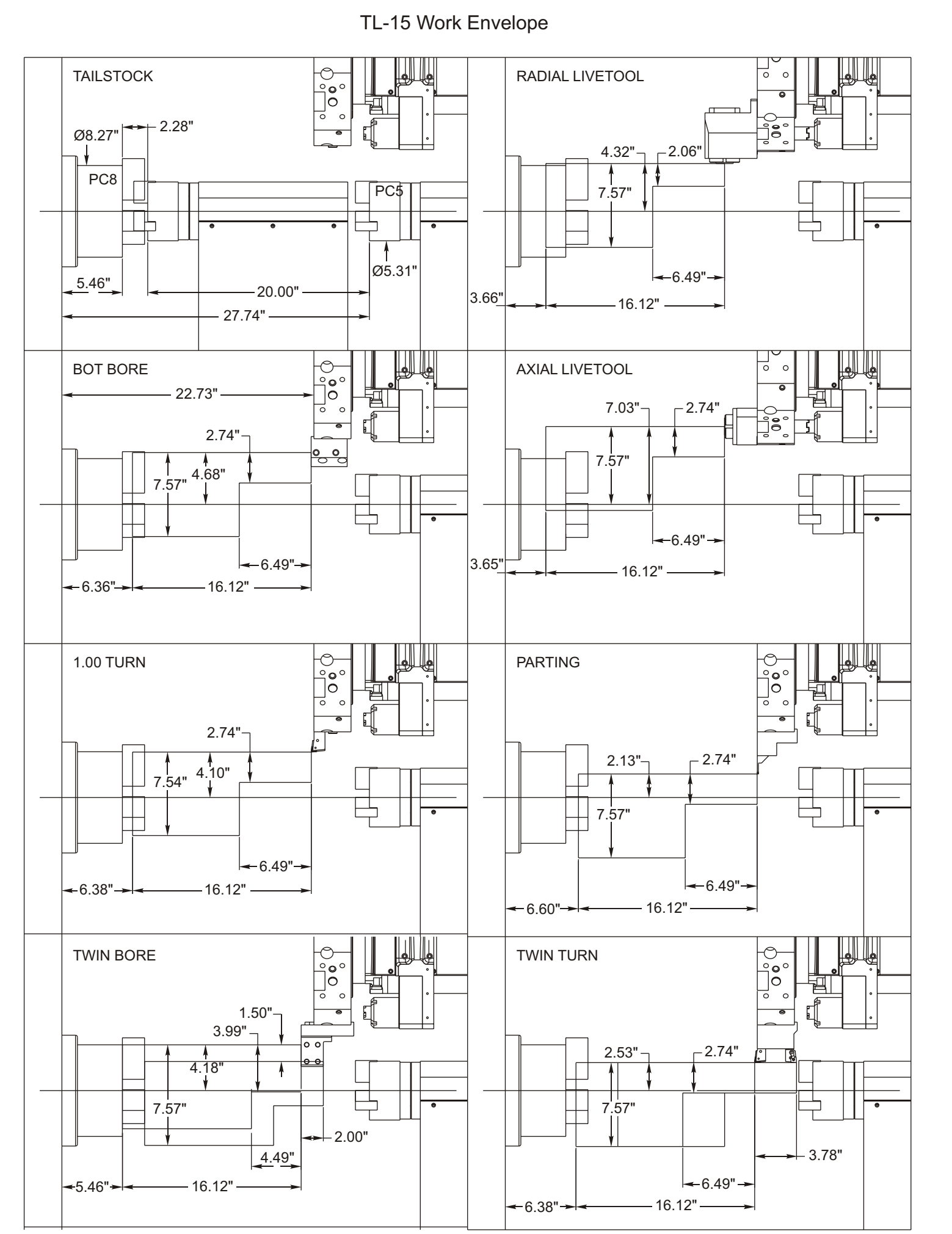
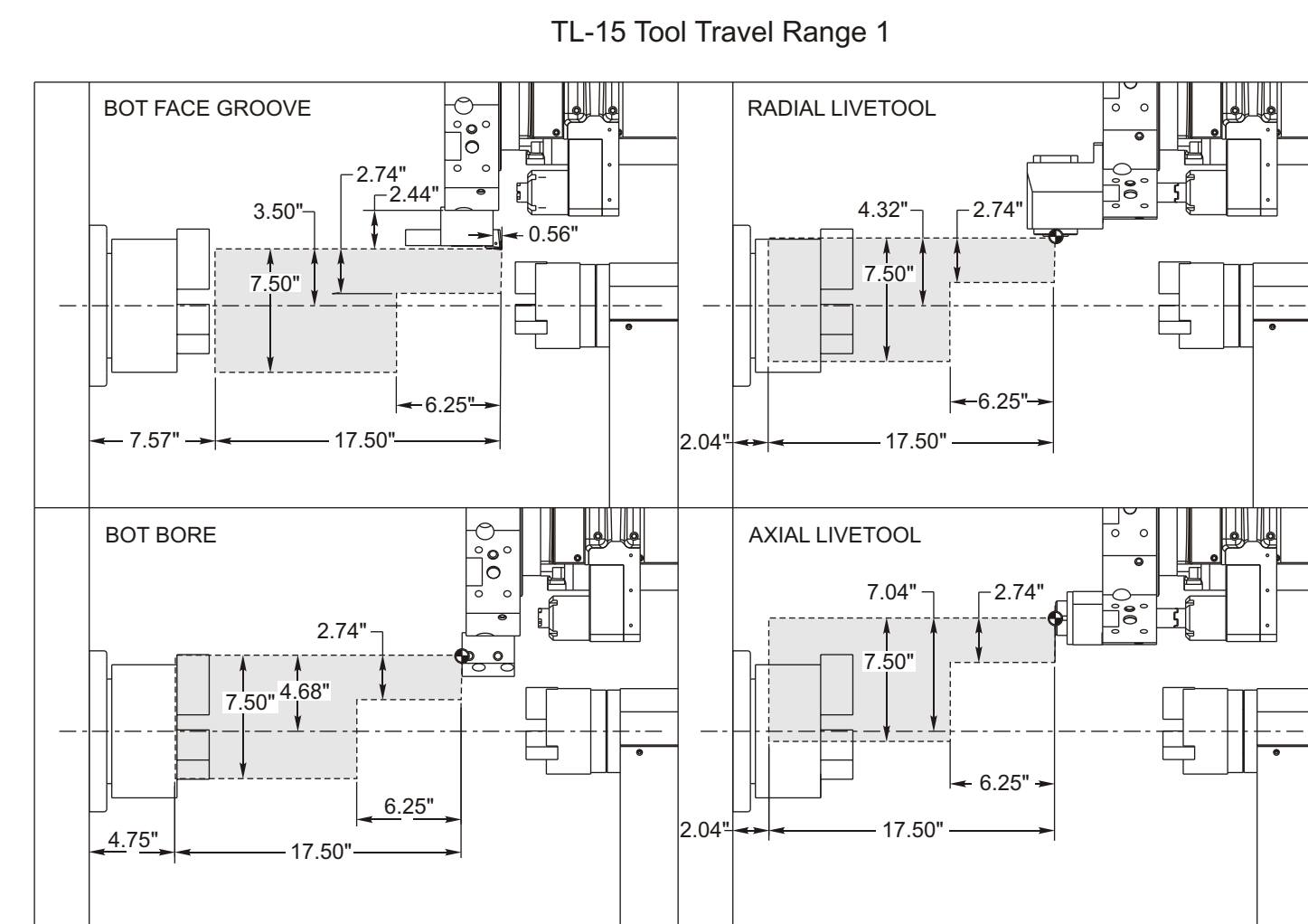
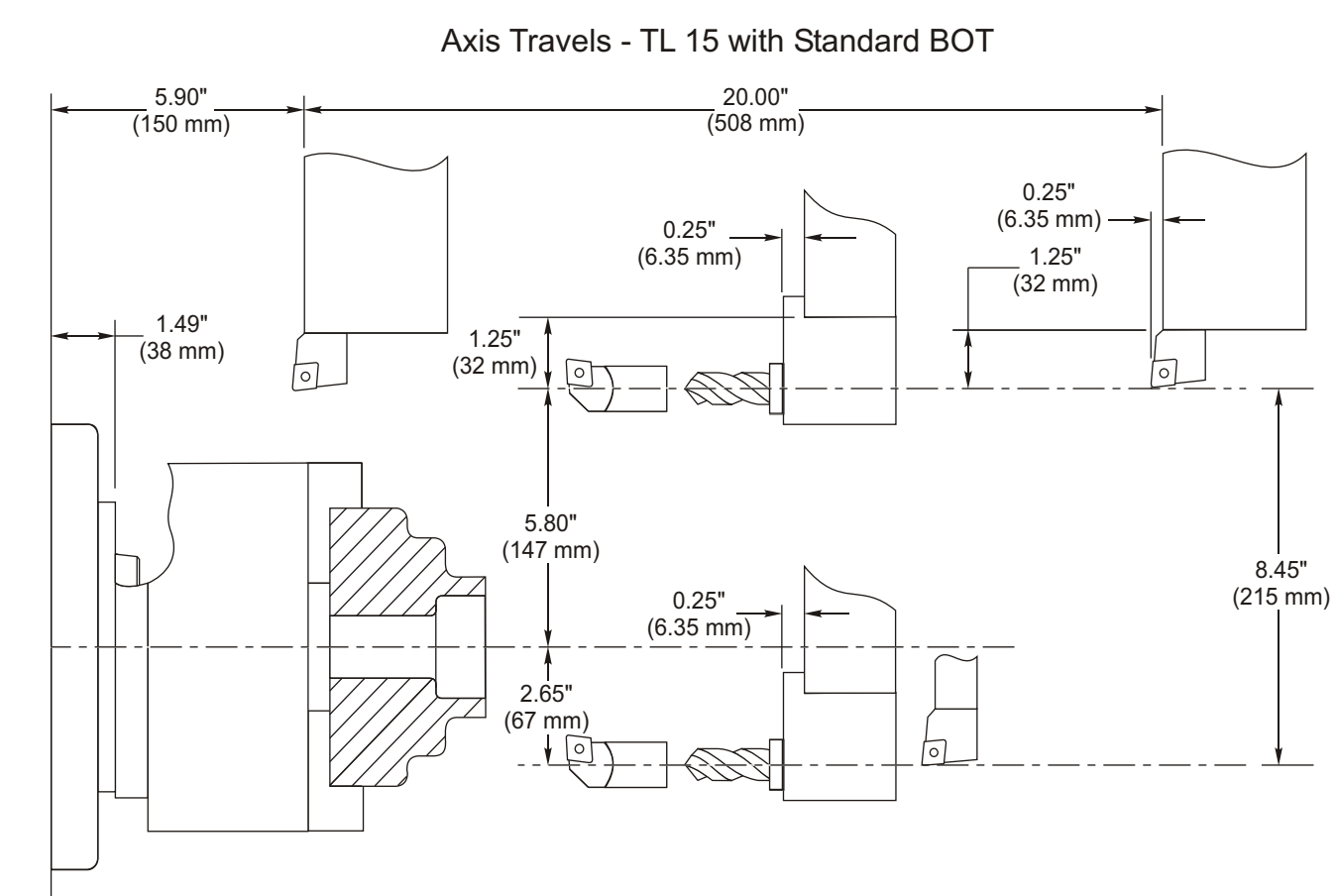
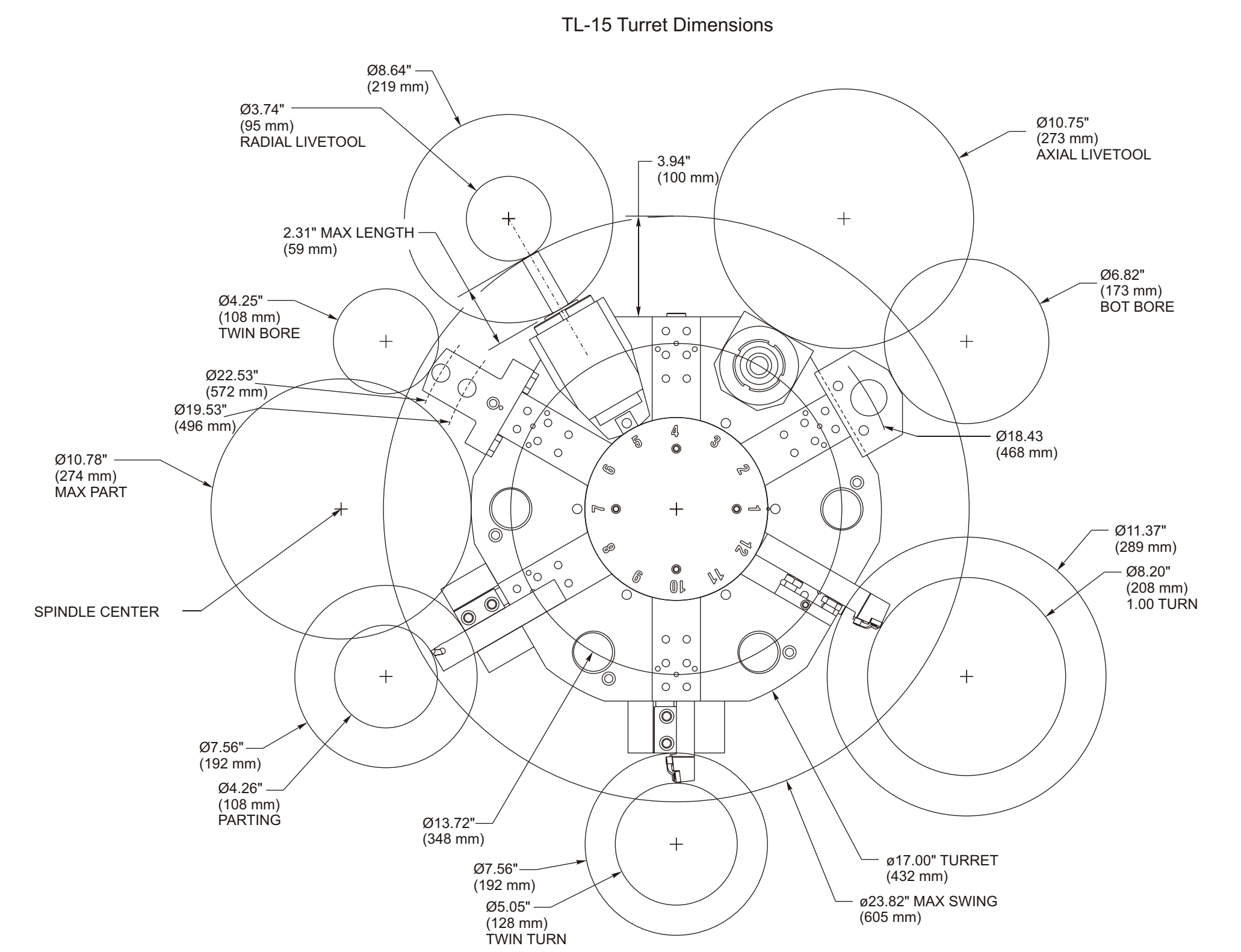
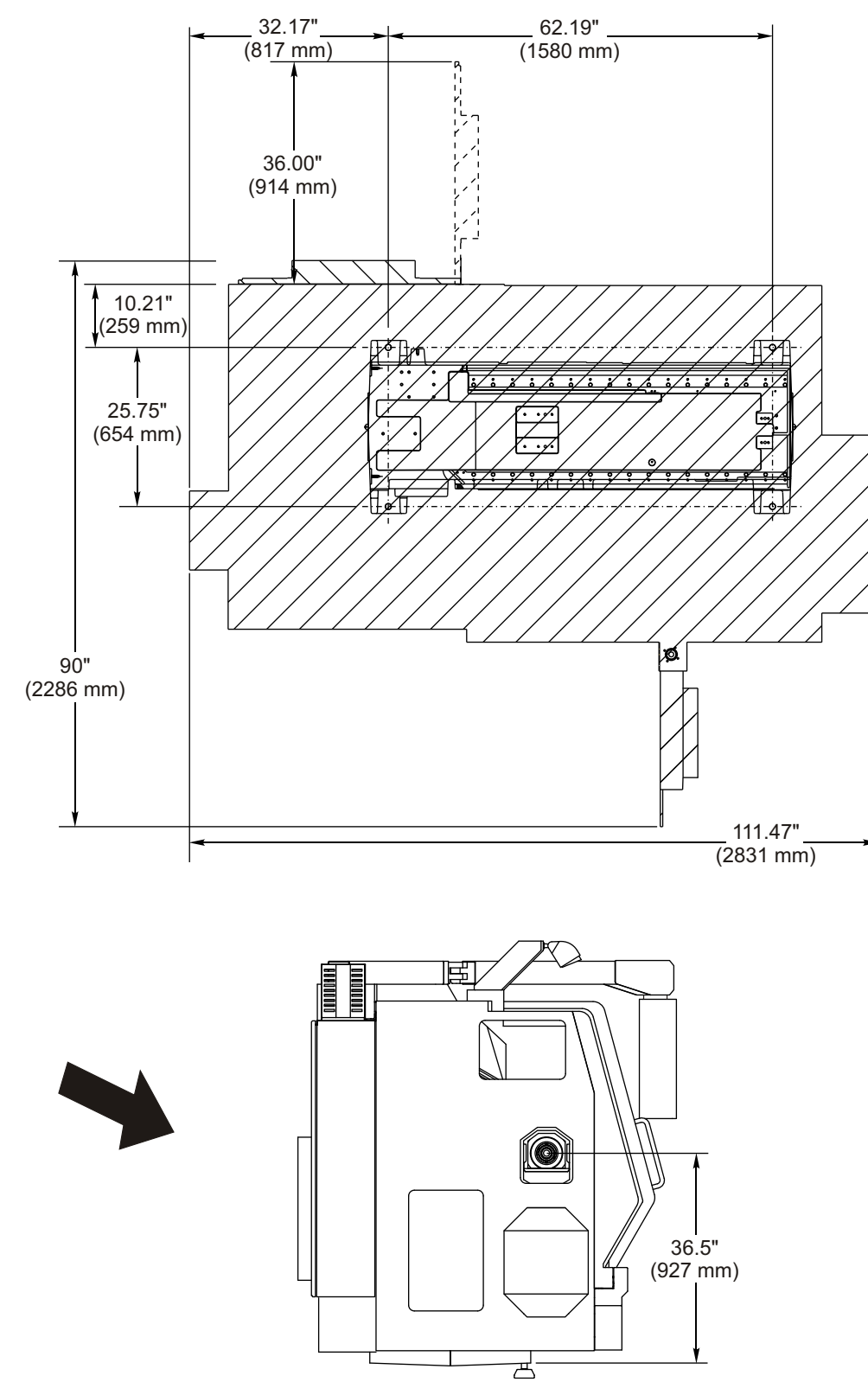
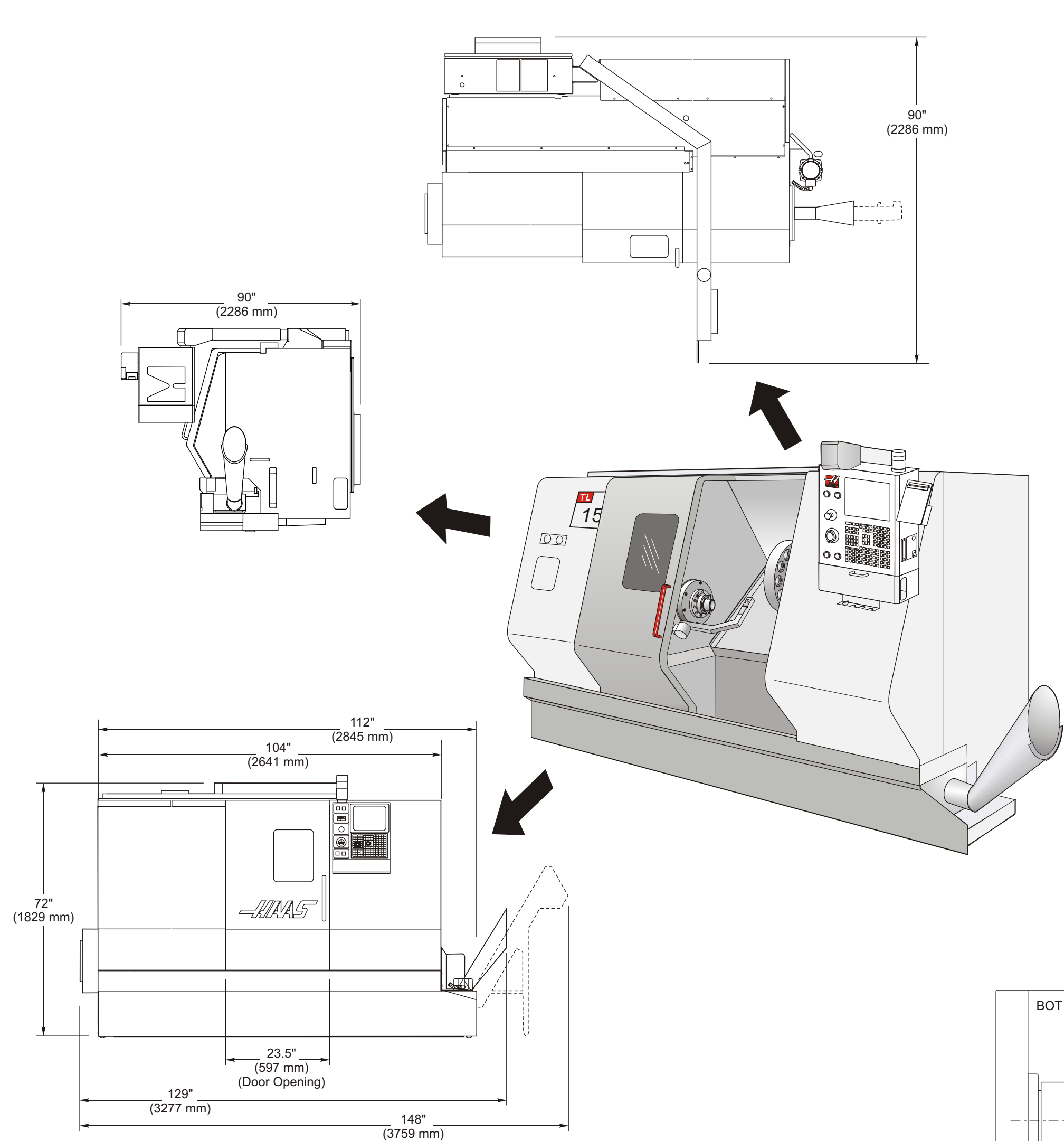

Turret Tooling Clearance - TL-15 with Standard 10-Pocket BOT

