



Productivity Inc®

**Haas SL-40 PRE-INSTALLATION CHECKLIST – Rev 01/2009**

Installation of your new Haas SL40 can be smooth and rapid if preparations are made prior to the delivery of your machine. Any questions regarding machine installation should be directed to our service department for clarification. We hope this checklist will aid in a rapid installation of your new machine. **NOTE: The following must be completed prior to our service technician arriving to install your new machine.**

- Power Requirements for your machine: 230v/3ph/28kVa\*\* 100 Amps (\*460v/3ph/28kVa, 50 Amps)  
**\*\*NOTE: for SL-40's with XP option, 230v/3ph/44kVa 150 Amps (460v/3ph/44kVa 80 Amp w/Transformer)**  
 Proper voltage per machine specifications should be ready at machine site. **Do NOT power up machine. A separate earth ground wire of the same conductor size as the input power must be connected to the chassis of the machine; must be supplied from the main plant ground. A local cold-water pipe or ground rod is not sufficient.**  
 \*460v requires External Transformer
- **NOTE REGARDING 1000 PSI High Pressure Coolant - You will need a separate power source. 208-230v/3ph/20 Amp circuit needed for the unit. The CNC does NOT provide the power source. Any questions, please contact our service department.**
- Customer should furnish and have available the proper supply and types of lubricants required for machine operation.

ITEM	CAPACITY	FLUID TYPE
Coolant	77 gallons	Water Soluble, synthetic, or cutting oil
Way Lube	80 ounces	Mobil Vactra #2

You will need to have Coolant and lubricants on hand at the time of installation. Contact our Service Department for more information.

- Air lines should be routed to the machine location and operational for proper air pressure.

The Lathe requires a minimum of 100 PSI at 4 cfm at the input to the pressure regulator on the back of the machine. This should be supplied by at least a 2-HP compressor, with a minimum 20-gal tank, that turns on when the pressure drops to 100 PSI. The air must be supplied through a minimum 3/8" hose and fittings must be at least 1/4" NPT.

- Machine location should be planned to allow enough room for access panels to be opened and serviced with ease.
- Weight requirements should be checked to insure that the surface below the machine will have sufficient strength for support and stability. The machine must be set on a solid, sound and stable, steel bar-reinforced concrete slab poured directly on the grade. In general, the 6" concrete floor on industrial buildings is suitable for machine placement.
- **NOTE: THE HAAS LATHE CANNOT BE CRANED WITHOUT PURCHASING THE LIFTING KIT, INSTALLED AT THE FACTORY AT TIME OF MANUFACTURE, OR IT MUST BE LIFTED WITH FORKLIFT. CONTACT YOUR SALESPERSON OR LOCAL SERVICE DEPARTMENT FOR MORE INFORMATION.** Upon arrival of your machine, **unpack and immediately check for visible damage.**

SHIPPING WEIGHT	SHIPPING DIMENSIONS OF MACHINE
26,660 # (Machine skidded)	18' L x 8'6" W x 9'6" H (skidded and packed)
2,085 # (Barfeeder)	8'6" L x 6' W x 5' H (Optional Bar feeder skidded and packed)
700 # (Chip Conveyor)	10'9" L x 3' W x 7' H (Chip Conveyor on skid)
See attached layout/machine spec sheet for floor space requirements on the machine and BAR.	

- Remove as much preservative from the machine as possible without having to power up (tables – slides, pulleys, etc.). We recommend mineral spirits to clean. Apply oil when finished to prevent rust.

**PLEASE FORWARD THIS TO THE APPROPRIATE PERSON. THANK YOU.**

## SL-40 DIMENSIONS/FLOOR LAYOUT

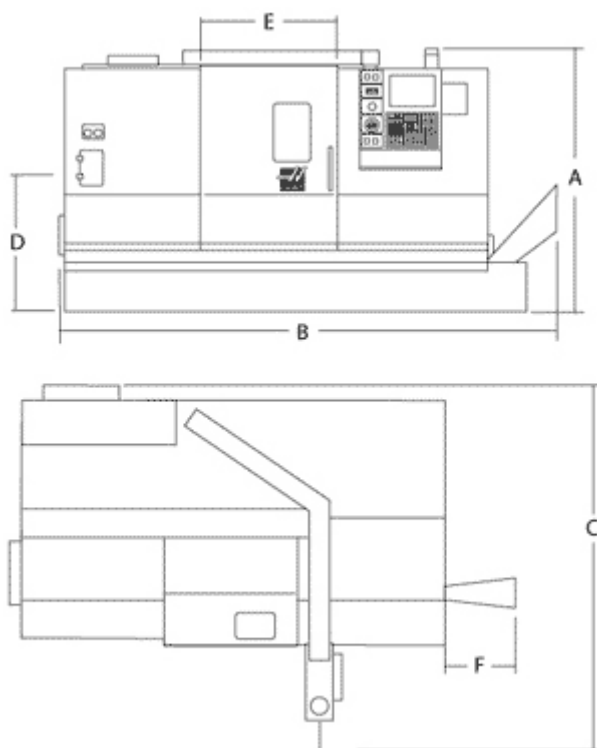

		Mix View
A	89	'''
B	190	'''
C	125	'''
D	47	'''
E	35	'''
F	35	'''

### Optional Haas Servo BAR Dimensions/Footprint

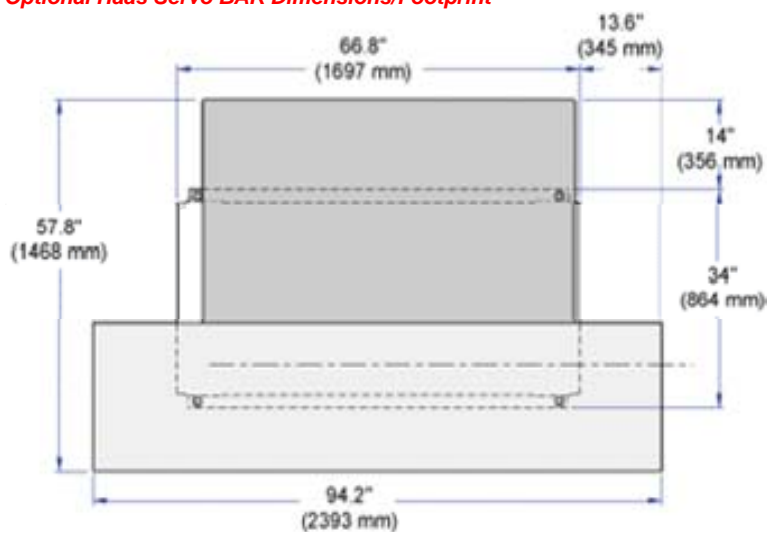

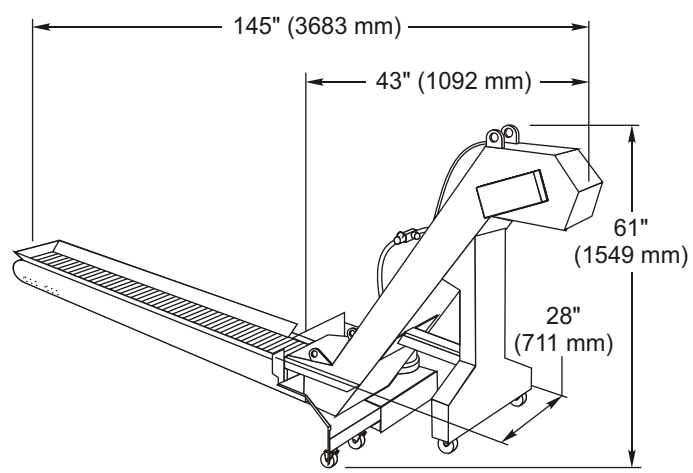
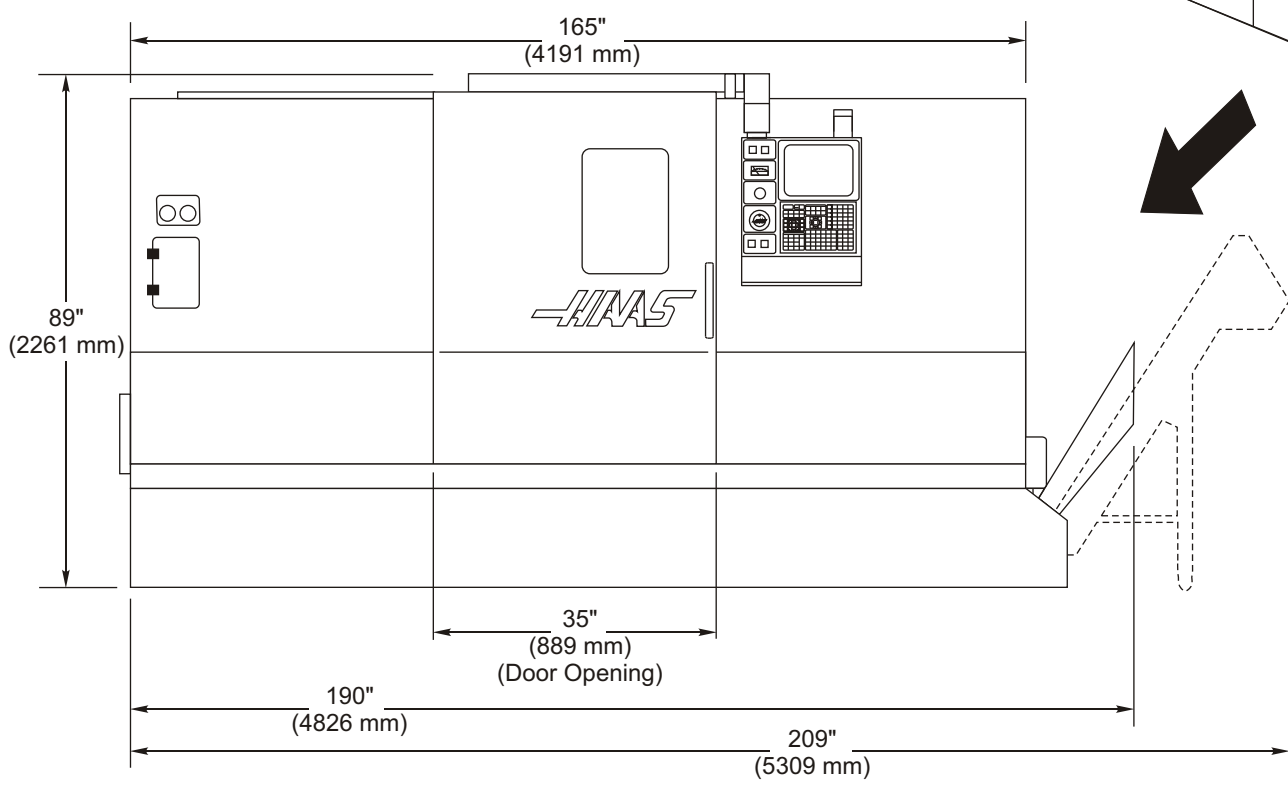
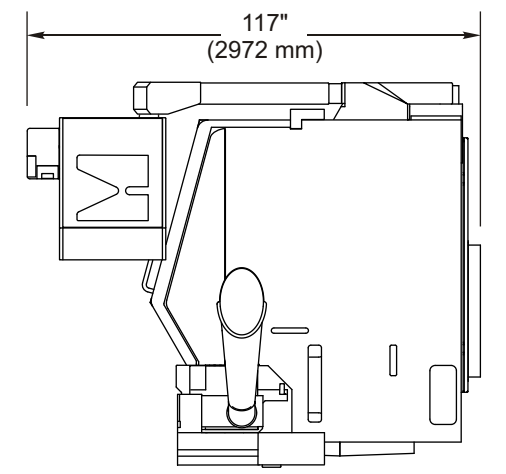
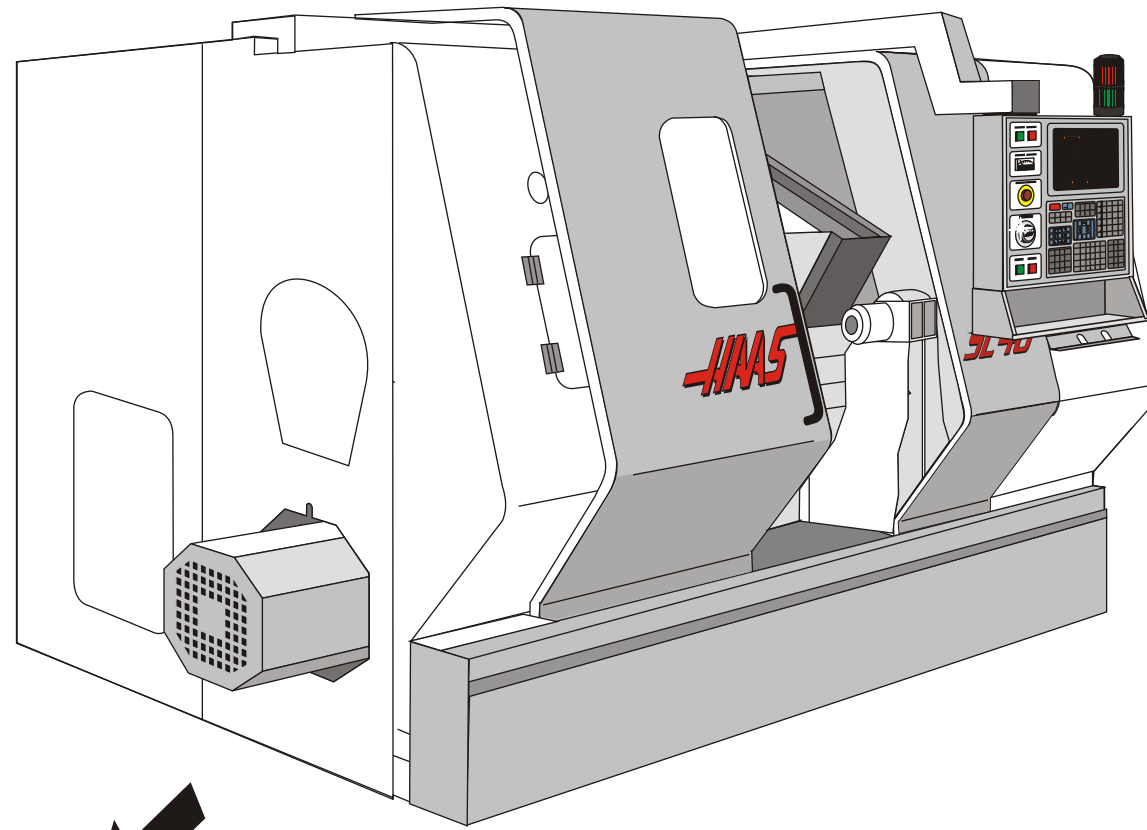
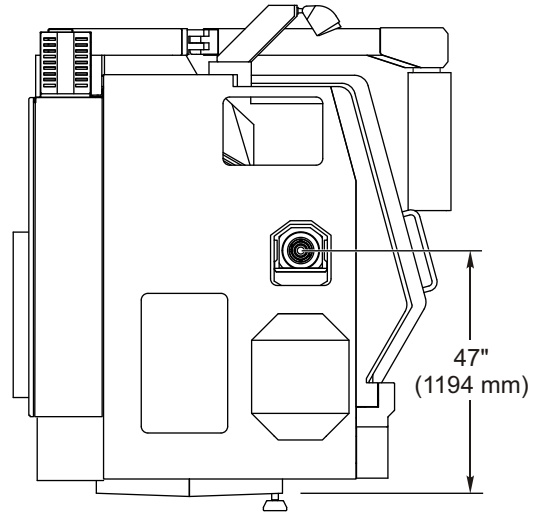
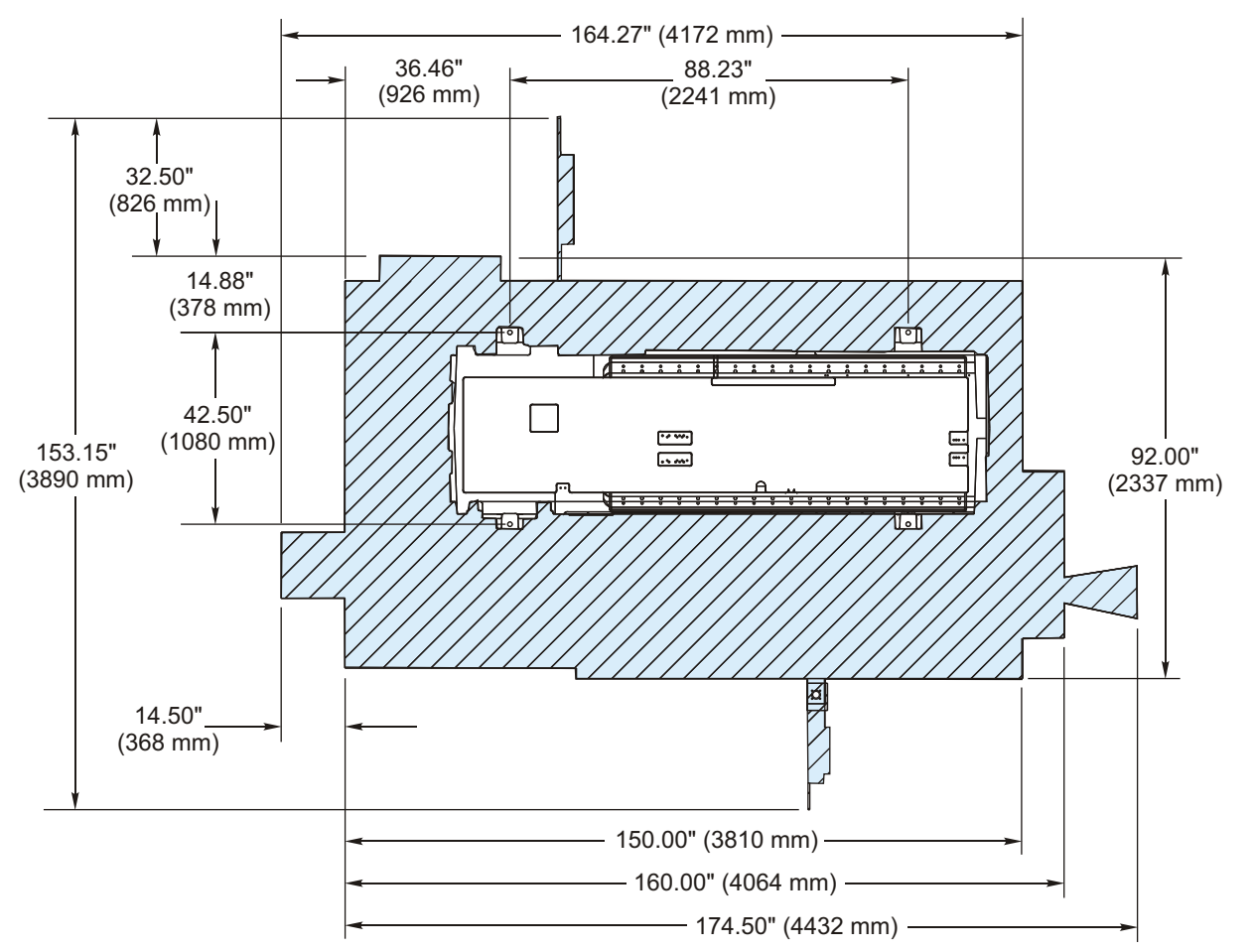
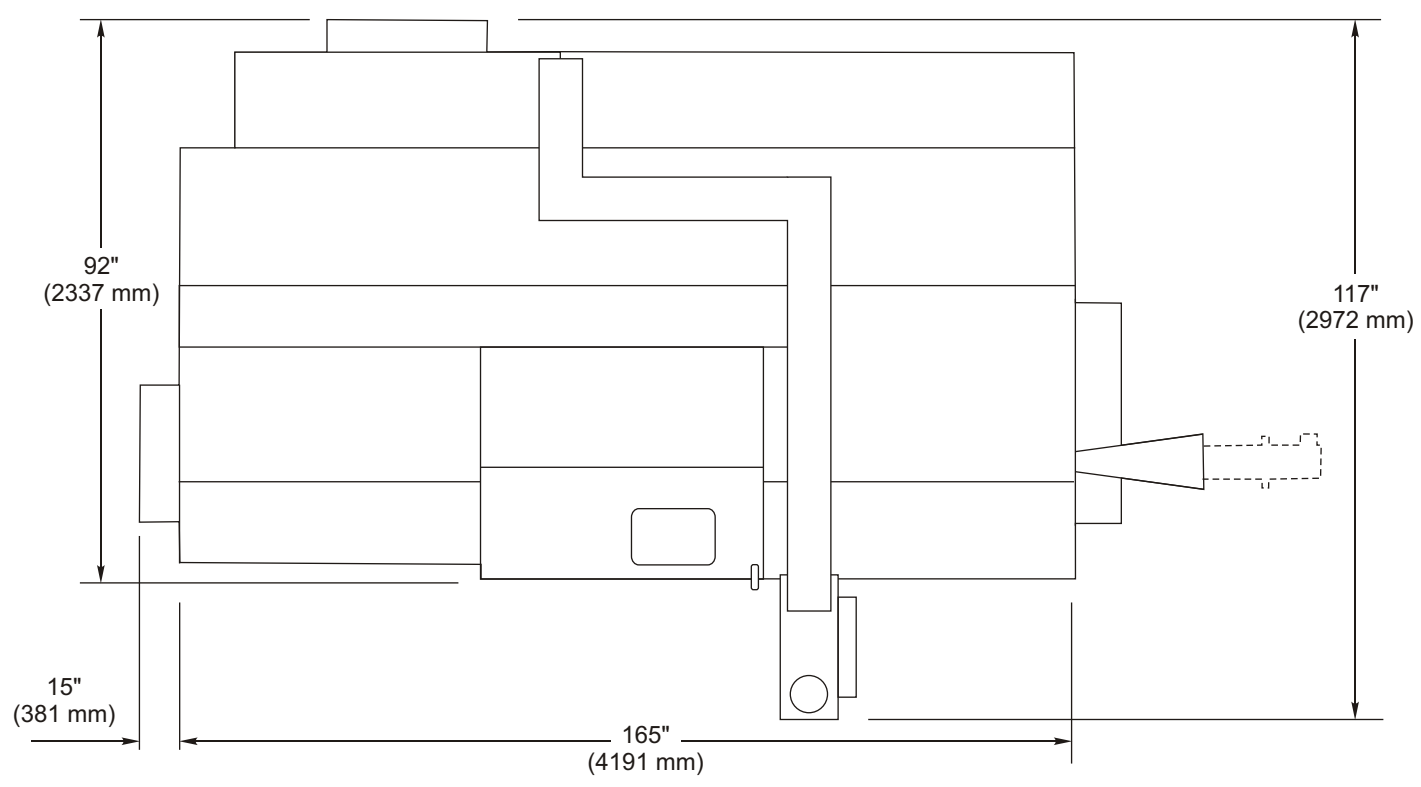

Installation/removal of the Chip Conveyor requires at least 145" of open space from the end of the machine.

Turret Tooling Clearance SL-40 10 Pocket

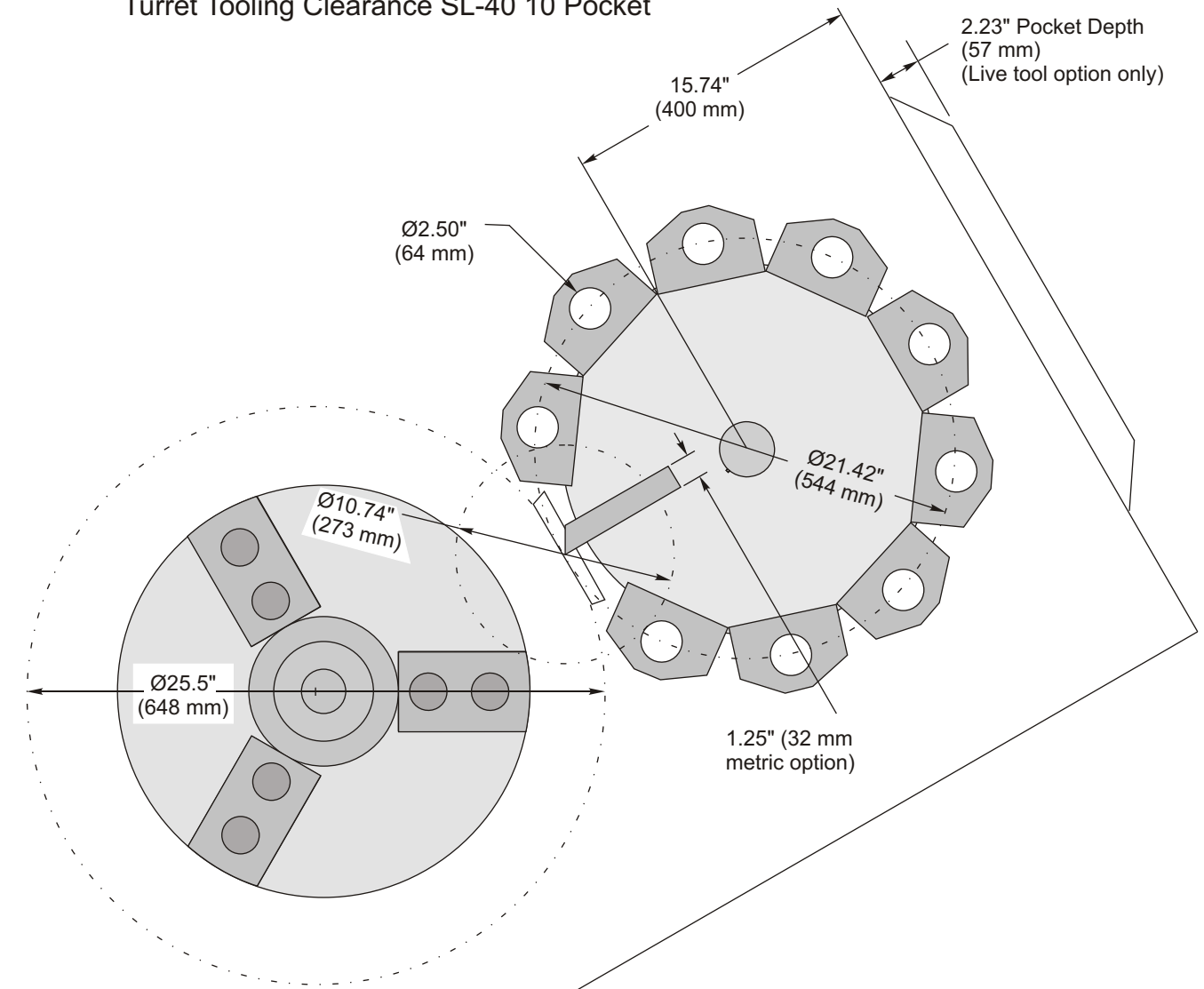

Axis Travel Diagram SL-40 BOT

