



Productivity Inc®

**EC-2000 PRE-INSTALLATION CHECKLIST** - Rev 01/2009

Installation of your new Haas EC-2000 can be smooth and rapid if preparations are made prior to the delivery of your machine. Any questions regarding machine installation should be directed to our service department for clarification. We hope this checklist will aid in a rapid installation of your new machine. **NOTE: You must have the following completed prior to our service technician arriving to install your machine.**

- Power Requirements for your machine: 230v/3ph/28kVa, 100 amps (460\*v/3ph/28kVa, 50 Amps)  
 Proper voltage per machine specifications should be ready at machine site. **Do NOT power up machine. A separate earth ground wire of the same conductor size as the input power must be connected to the chassis of the machine; must be supplied from the main plant ground. A local cold-water pipe or ground rod is not sufficient.**  
 \*460v will require an Internal or External Transformer.

**\*\*\*NOTE: If you have purchased the 1000 psi High Pressure Coolant option, you will need a separate power source. 208-230v/3ph/20 Amp circuit is needed for the unit. The CNC does NOT provide the power source. Any questions, please contact our Service Department.\*\*\***

- Customer should furnish and have available the proper supply and types of lubricants required for machine operation.

ITEM	CAPACITY	FLUID TYPE
Coolant	95 gallons	Water Soluble, synthetic (NON-FLAMMABLE)
Way Lube	64-80 oz	Mobil <b>DTE25 (50T)</b>

You will need to have Coolant and lubricants on hand at the time of installation. Contact our Service Department for more information.

- Air lines should be routed to the machine location and operational for proper air pressure.

The Horizontal Machining Center requires a minimum of 100 PSI at 9 cfm at the input to the pressure regulator on the back of the machine. This should be supplied by at least a 2-HP compressor, with a minimum 20-gal tank, that turns on when the pressure drops to 100 PSI. The air must be supplied through a minimum ½” – 1” diameter air line and fittings must be at least ¼” NPT.

- Machine location should be planned to allow enough room for access panels to be opened and serviced with ease. A minimum of 36” clearance is required around the machine for operator and maintenance access.
- Weight requirements should be checked to insure that the surface below the machine will have sufficient strength for support and stability. The machine must be set on a solid, sound and stable, steel bar-reinforced concrete slab poured directly on the grade. In general, the 6” concrete floor on industrial buildings is suitable for machine placement. **The machine should be anchored for best performance and accuracy, and will need to be done prior to the machine’s arrival. See Anchoring Instructions – document #ES0095 for instructions and information, found in your Anchor Kit. If you do not have an anchor kit, contact Hope, your Customer Advocate at 763-476-8600.**
- **NOTE: THE HAAS HMC is best moved using a forklift. If you plan to use a crane, you will need a lifting kit (call our Service Department or Hope Riska 763-742-1275 for more information). Upon arrival of your machine, uncrate and immediately check for visible damage.**

SHIPPING WEIGHT	SHIPPING DIMENSIONS OF MACHINE
33,820 lbs (Skidded)	16’8” L x 12’ W x 11’3” H (Skidded/Packed) <b>Requires permits and double-drop.</b>
Operational: 32,500#, See attached for layout/dimensions. Allow 36” around the machine for operator/maintenance access.	

- Remove as much preservative from the machine as possible without having to power up (tables – slides, pulleys, etc.). We recommend mineral spirits to clean. Apply oil when finished to prevent rust.

**PLEASE FORWARD THIS TO THE APPROPRIATE PERSON. THANK YOU.**

**EC-2000 Dimensions/Floor Space**

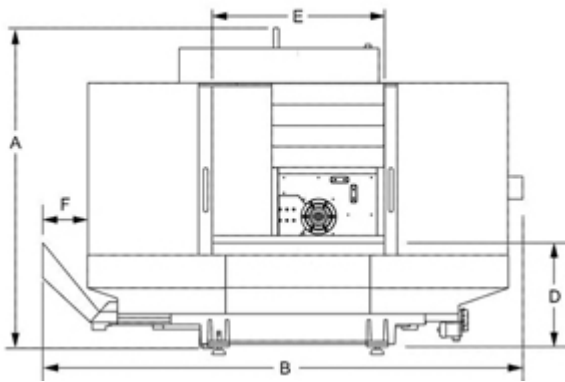
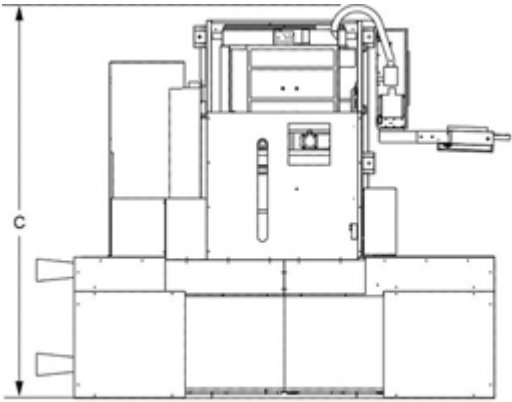

	Mix View	
E	82 "	
A	119 "	
B	195 "	
C	142 "	
D	36 "	
F	14 "	

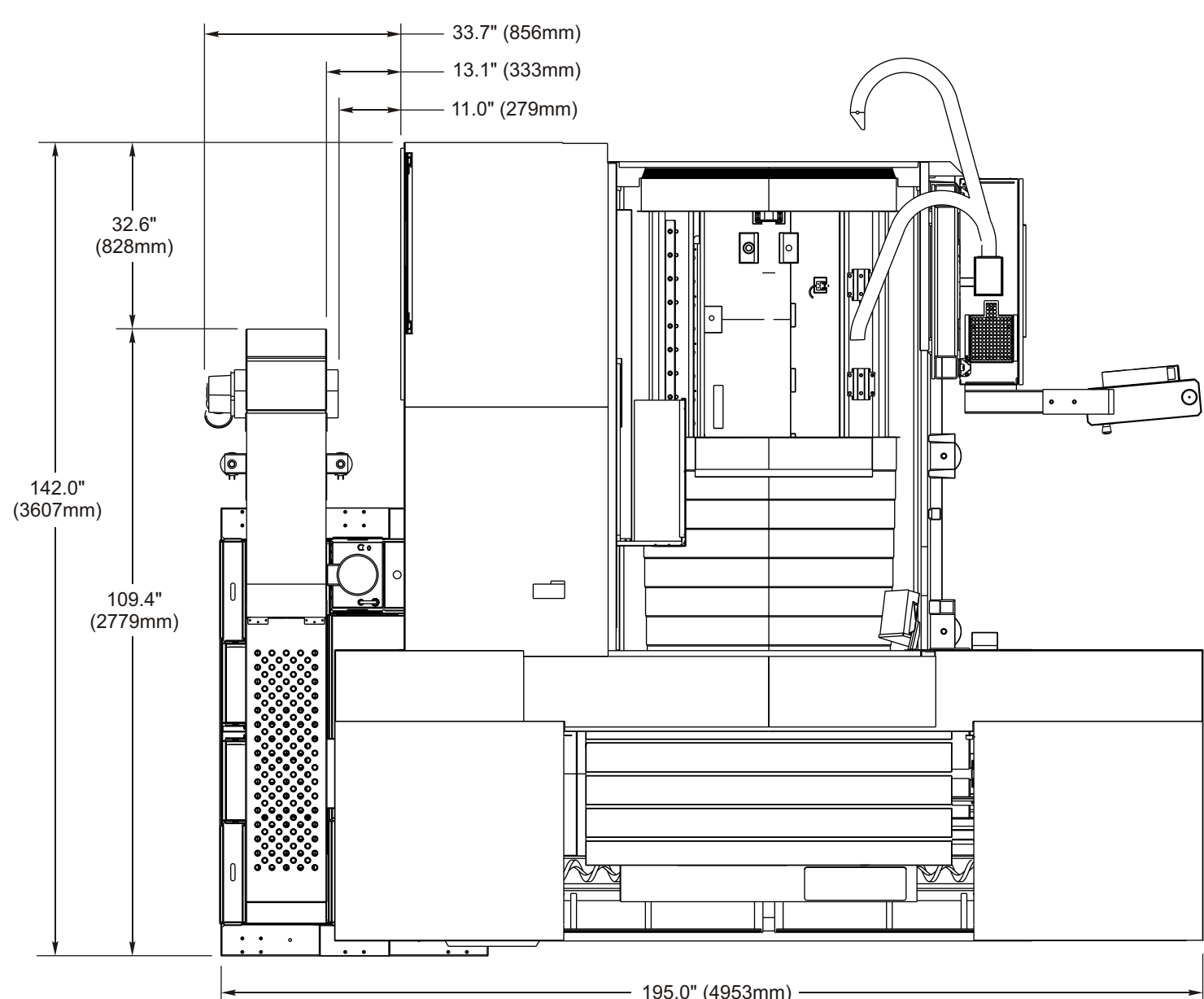
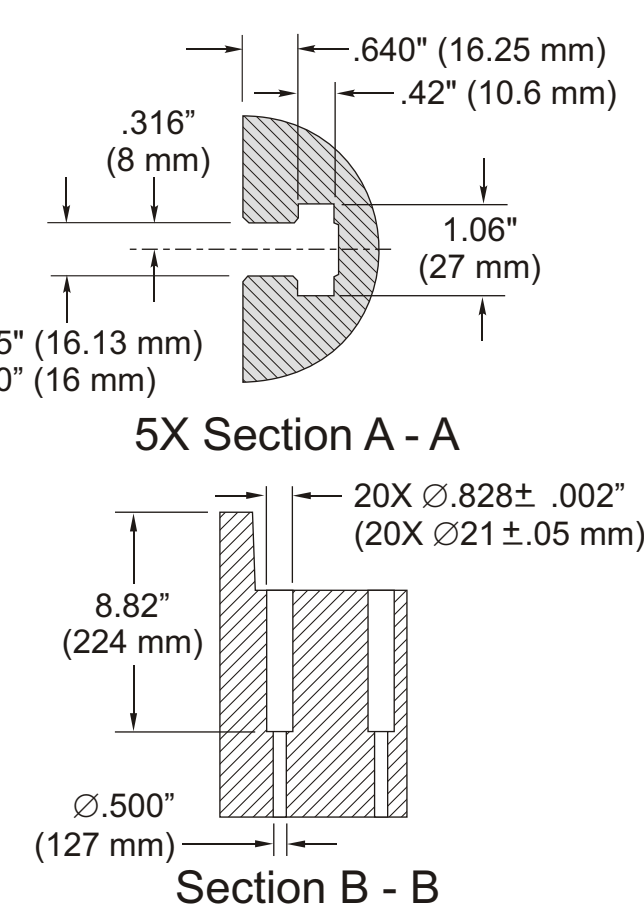
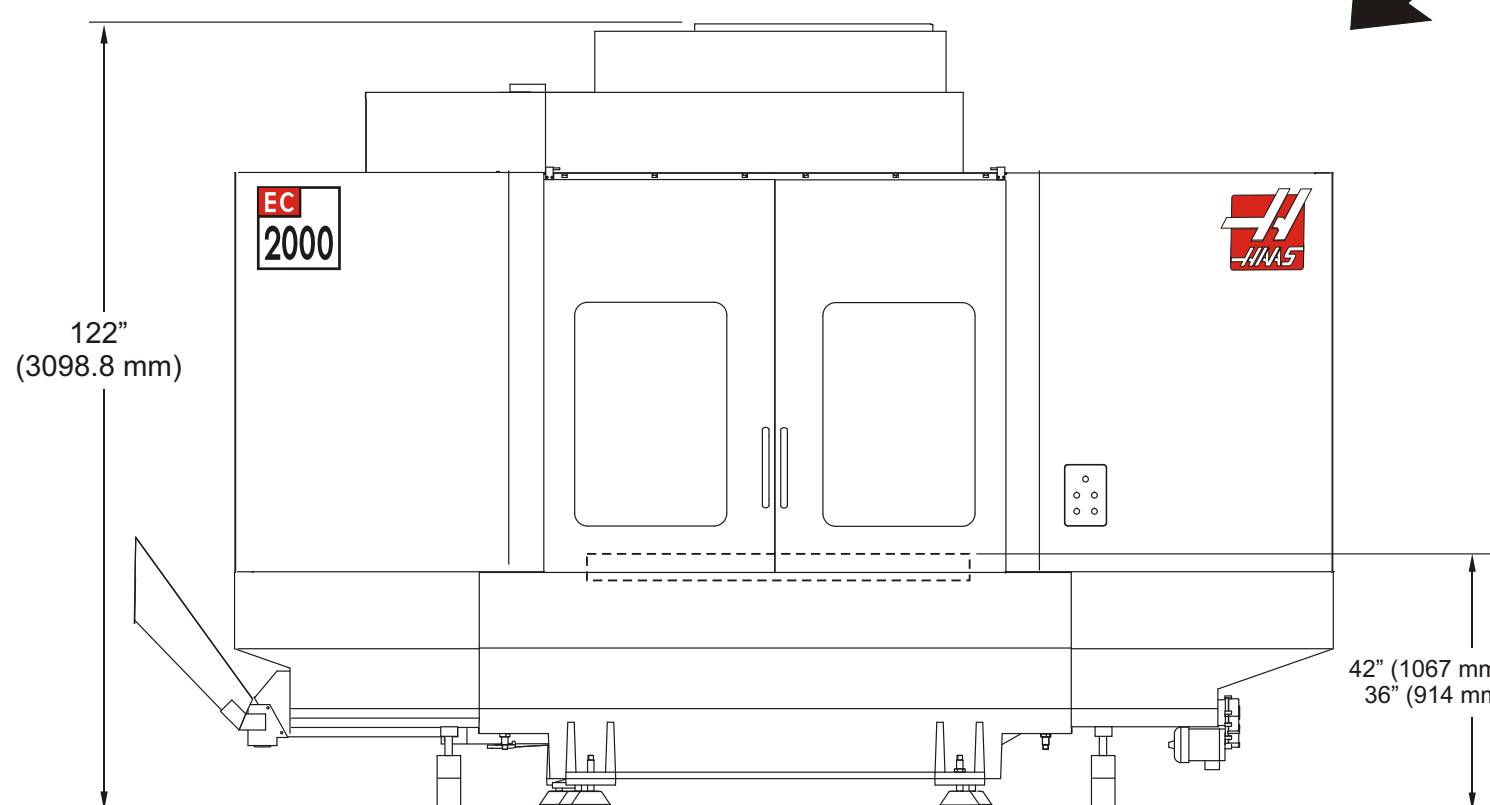
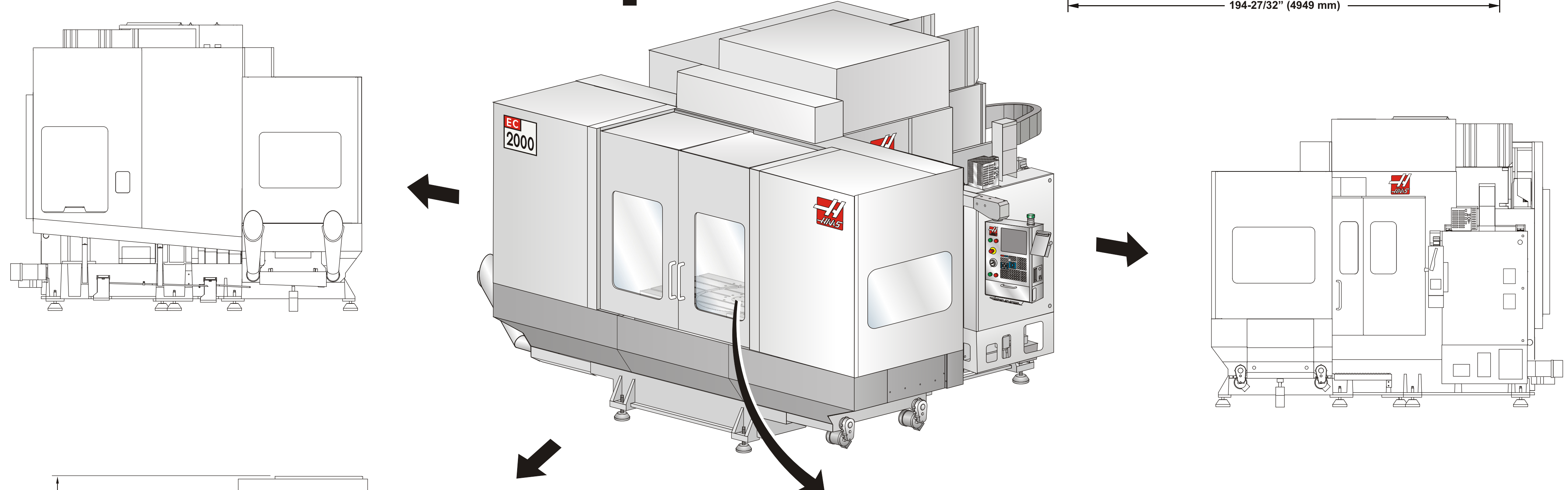
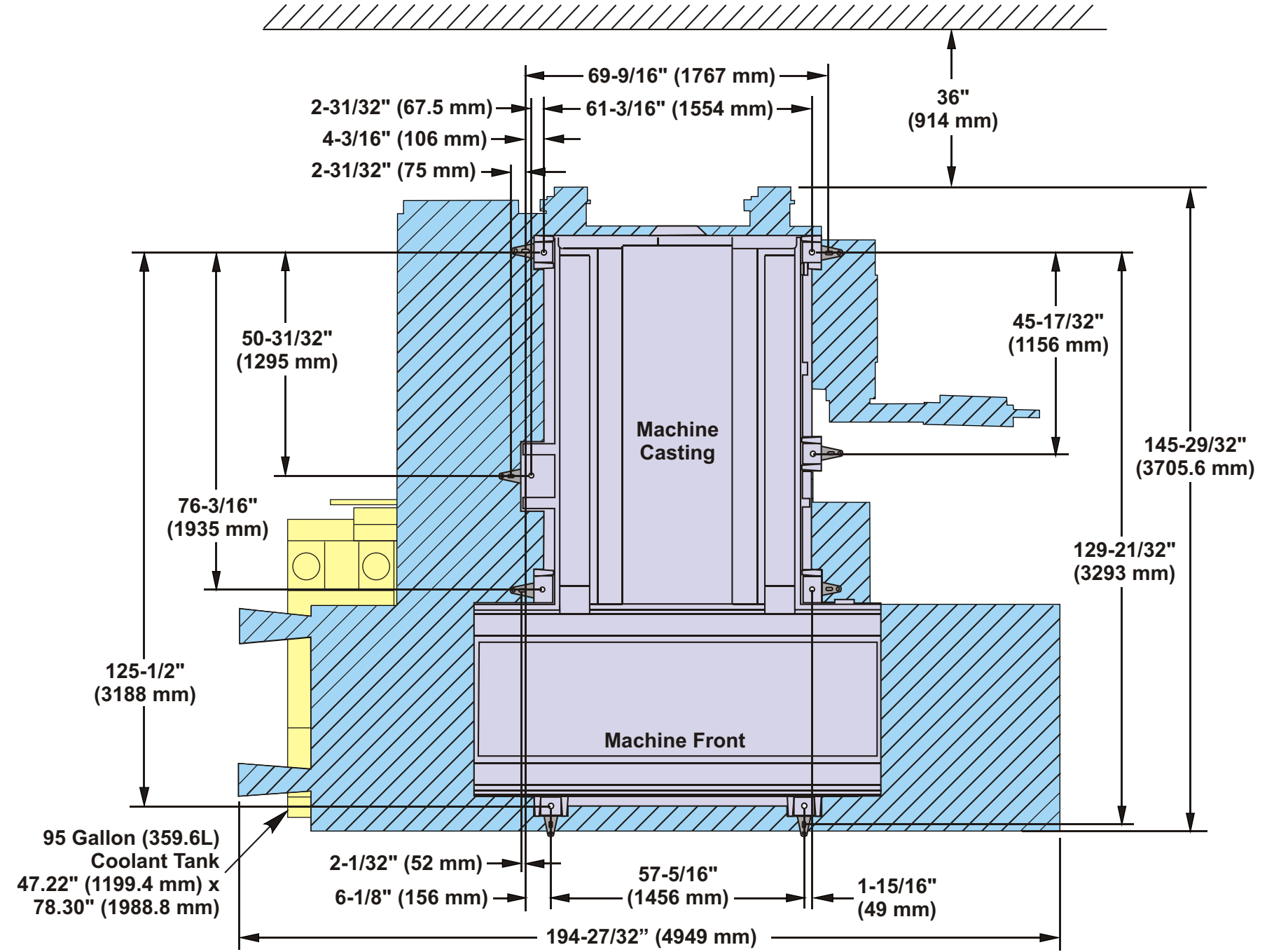
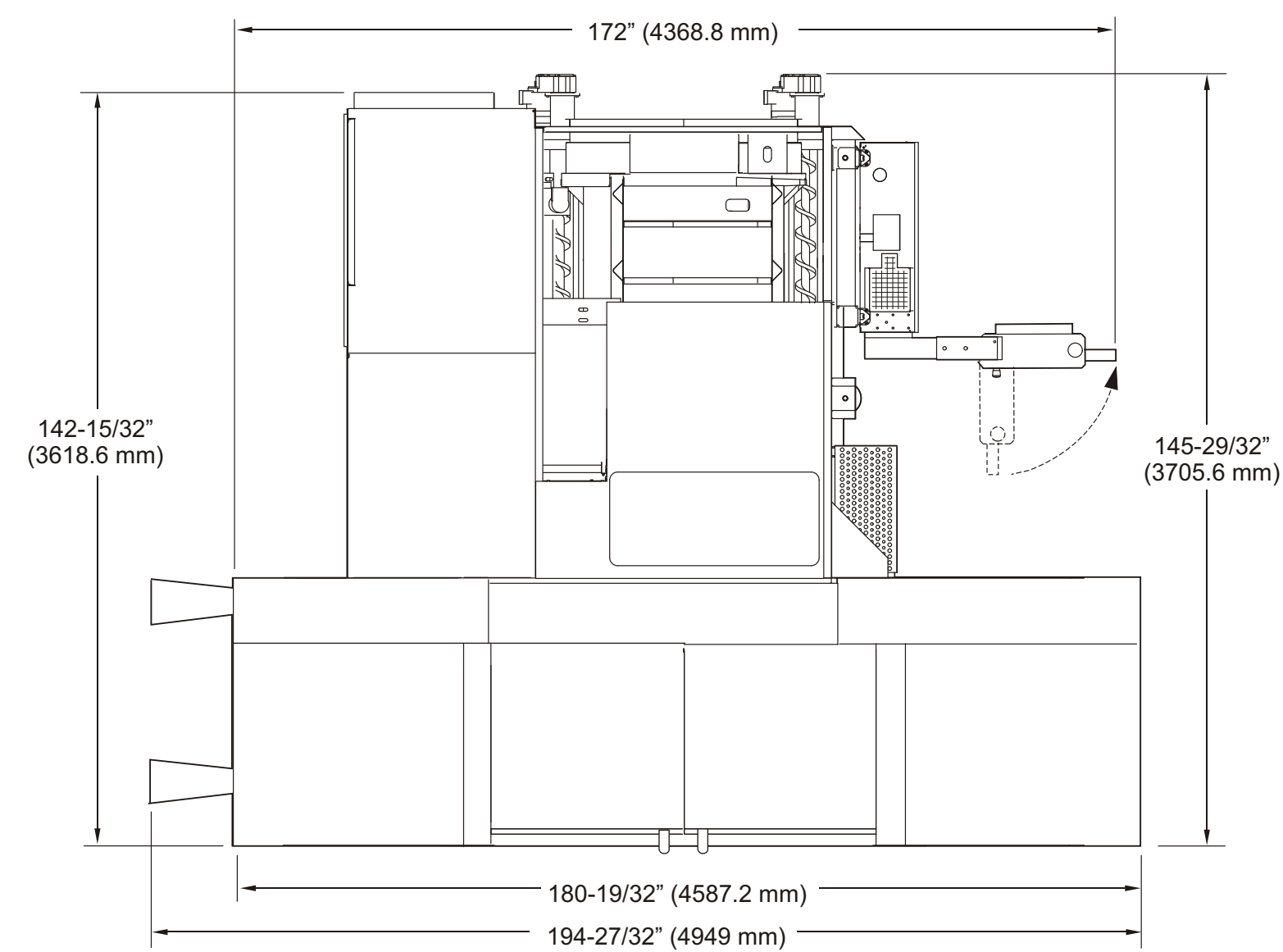

EC-2000 CHIP CONVEYOR DIMENSIONS

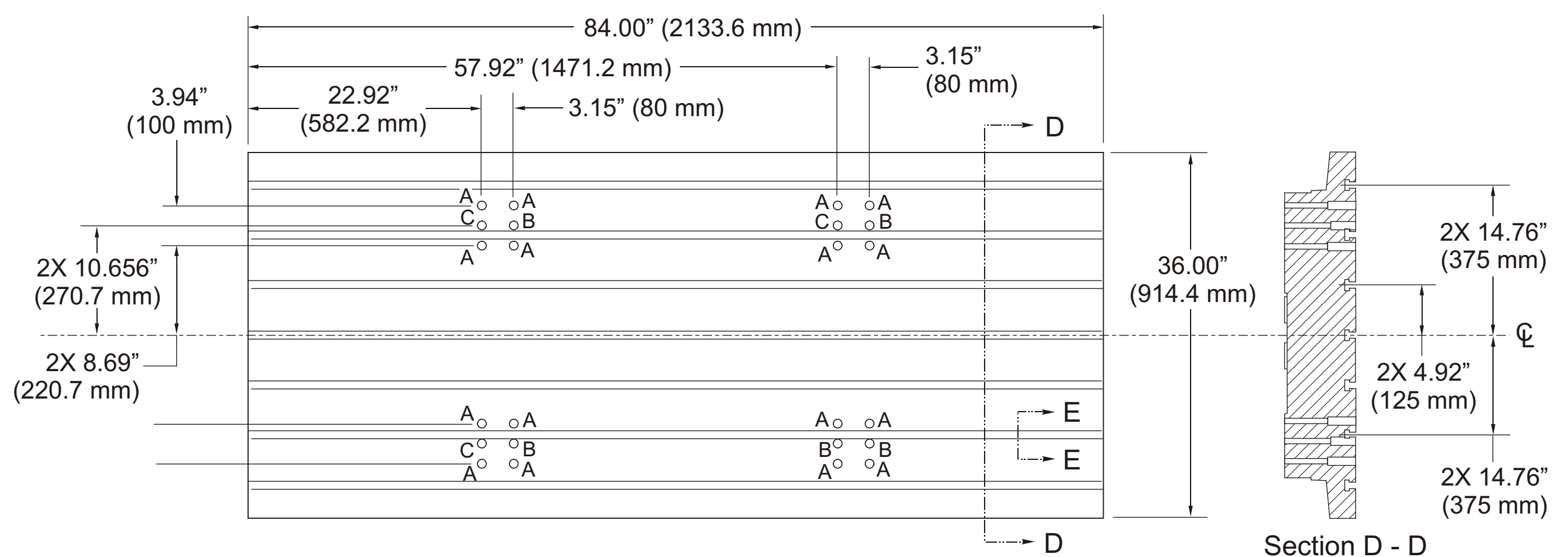

A	Ø.531 Thru x CBore Ø.828 x 2.75" Deep (Ø13.5 Thru x CBore Ø21 x 69.9 mm Deep)	16X
B	Ø.531 Thru x CBore Ø.828 x 2.45" Deep (Ø13.5 Thru x CBore Ø21 x 62.2 mm Deep)	5X
C	Ø.531 x 6.4" Deep From Top Surface, (CBore Ø.828") 2.45" Deep (Ø13.5 x 162.5 Deep From Top Surface, (CBore Ø21 x 62.2 mm Deep)	3X

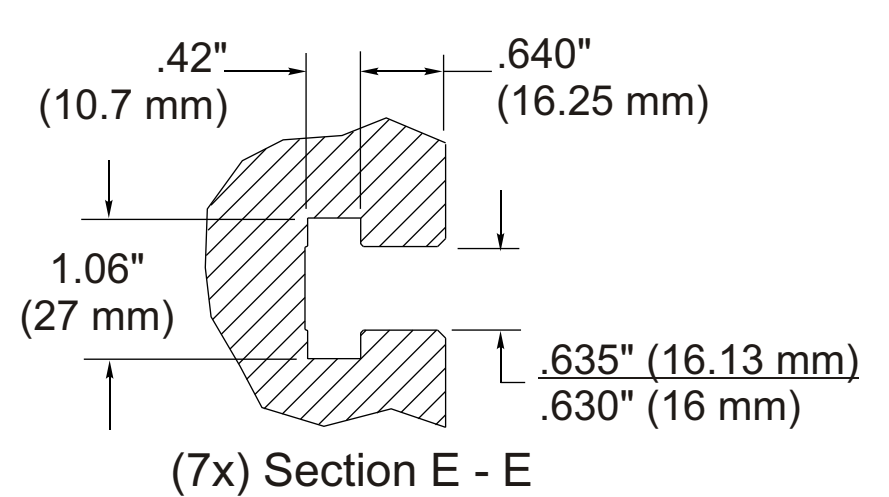

EC-2000 Table Dimensions (3-Axis)

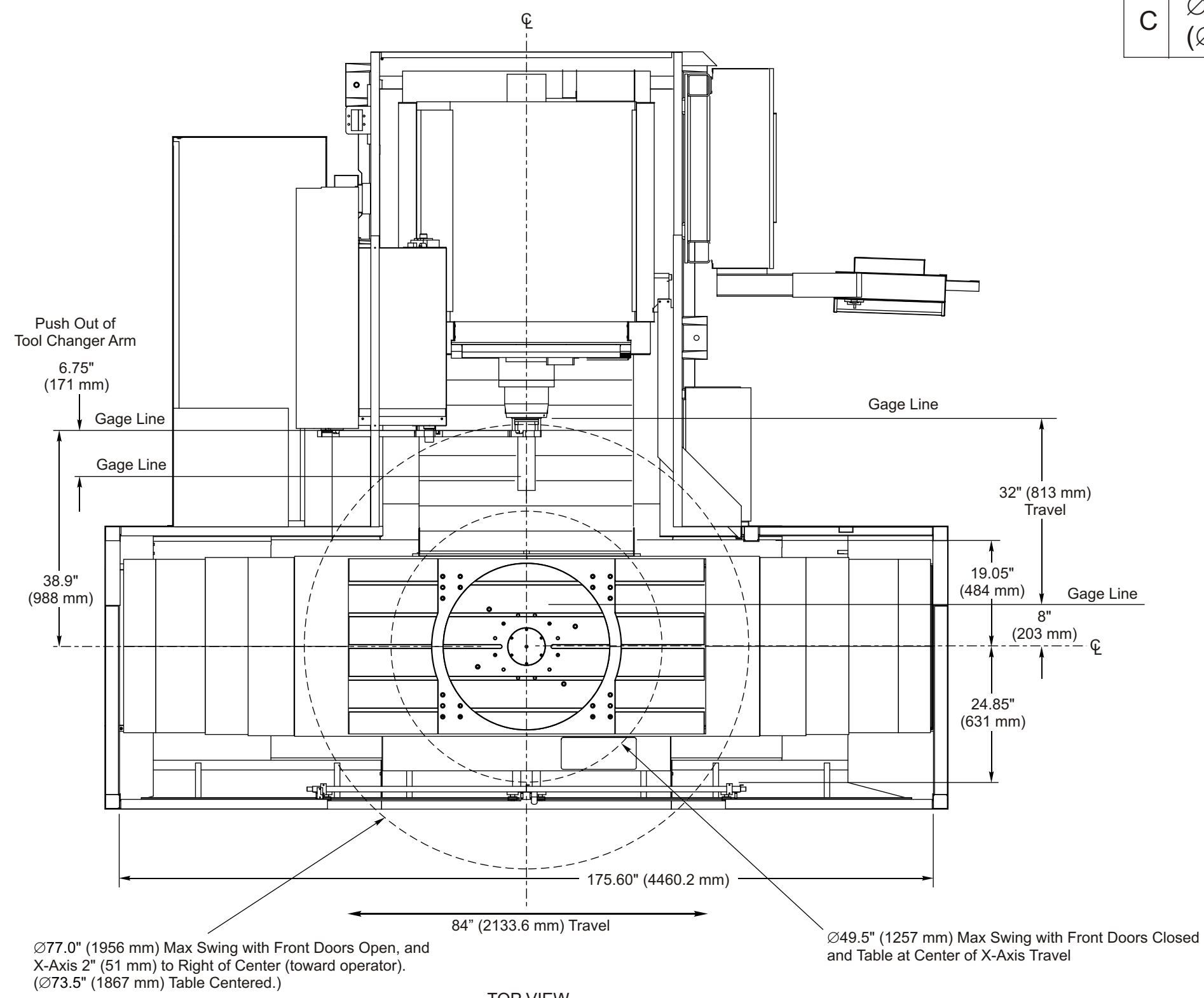

TOP VIEW

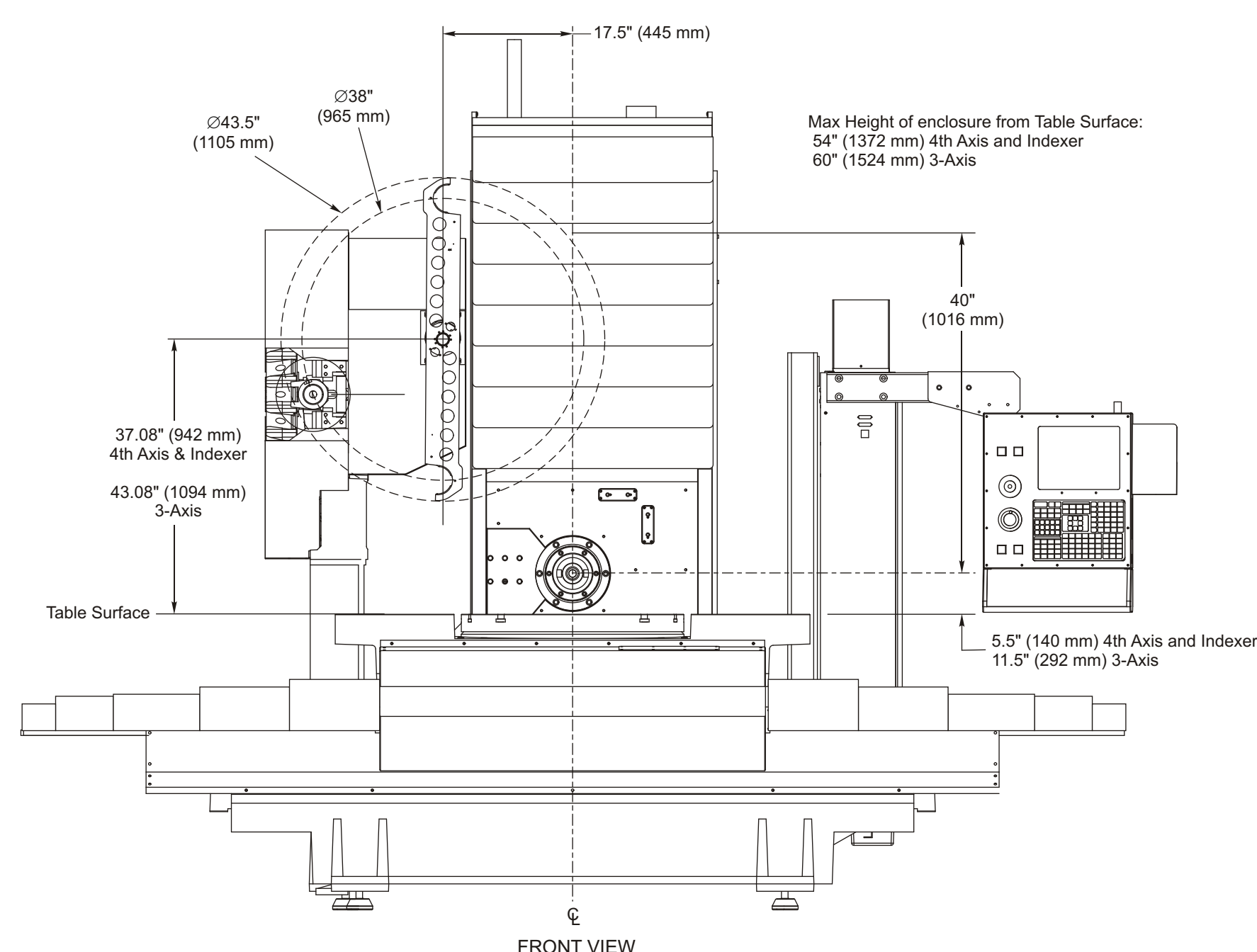

FRONT VIEW

EC-2000 Enclosure Work Space